



**YAMAHA**

**DT125RE<sup>2005</sup>**  
1D01-AE1

**DT125X**

**SERVICE MANUAL**

---

EAS00001

**DT125RE/X  
1D01-1D02/2C81  
SERVICE MANUAL**  
© 2005 Yamaha Motor España, S.A.  
1st Edition, January 2005  
All rights reserved. Any reprinting or  
unauthorized use without the written  
permission of Yamaha Motor España, S.A.  
is expressly prohibited.  
Printed in Spain.

---

## NOTICE

This manual was produced by the Yamaha Motor España S.A. primarily for use by Yamaha dealers and their qualified mechanics. It is not possible to include all the knowledge of a mechanic in one manual. Therefore, anyone who uses this book to perform maintenance and repairs on Yamaha vehicles should have a basic understanding of mechanics and the techniques to repair these types of vehicles. Repair and maintenance work attempted by anyone without this knowledge is likely to render the vehicle unsafe and unfit for use.

Yamaha Motor España S.A is continually striving to improve all of its models. Modifications and significant changes in specifications or procedures will be forwarded to all authorized Yamaha dealers and will appear in future editions of this manual where applicable.

**NOTE:** 

---

Designs and specifications are subject to change without notice.

---

TECHNICAL PUBLICATIONS  
YAMAHA MOTOR ESPAÑA, S.A.

## IMPORTANT MANUAL INFORMATION

Particularly important information is distinguished in this manual by the following.



The Safety Alert Symbol means ATTENTION! BECOME ALERT! YOUR SAFETY IS INVOLVED!

**! WARNING**

Failure to follow WARNING instructions could result in severe injury or death to the motorcycle operator, a bystander or a person checking or repairing the motorcycle.

**CAUTION**

A CAUTION indicates special precautions that must be taken to avoid damage to the motorcycle.

**NOTE :**

A NOTE provides key information to make procedures easier or clearer.

# HOW TO USE THIS MANUAL

This manual is intended as a handy, easy-to-read reference book for the mechanic. Comprehensive explanations of all installation, removal, disassembly, assembly, repair and check procedures are laid out with the individual steps in sequential order.

- ① The manual is divided into chapters. An abbreviation and symbol in the upper right corner of each page indicate the current chapter. Refer to "SYMBOLS".
- ② Each chapter is divided into sections. The current section title is shown at the top of each page, except in Chapter 3 ("PERIODIC CHECKS AND ADJUSTMENTS"), where the sub-section title(s) appears.
- ③ Sub-section titles appear in smaller print than the section title.
- ④ To help identify parts and clarify procedure steps, there are exploded diagrams at the start of each removal and disassembly section.
- ⑤ Numbers are given in the order of the jobs in the exploded diagram. A circled number indicates a disassembly step.
- ⑥ Symbols indicate parts to be lubricated or replaced. Refer to "SYMBOLS".
- ⑦ A job instruction chart accompanies the exploded diagram, providing the order of jobs, names of parts, notes in jobs, etc.
- ⑧ Jobs requiring more information (such as special tools and technical data) are described sequentially.

**INSPECTION AND REPAIR** MOT

**INSPECTION AND REPAIR**

**CYLINDER HEAD**

1. Eliminate:

- Carbon deposits
- Use a rounded scraper ①

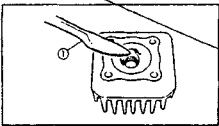

2. Inspect:

- Warping of cylinder head
- Out of specification → Correct

**Steps for measuring and correcting warp:**

- Place a straight edge ① and a thickness gauge ② against the head
- Measure the warp limit.

Warp limit:  
0.02 mm

- If warp is out of specification, straighten the head.

**NOTE:**

Rotate the head several times to avoid removing too much material from one side.

---

**CYLINDER AND PISTON**

1. Eliminate:

- Carbon deposits
- Use a rounded file ①

2. Inspect:

- Cylinder wall
- Wear/Scratches → Rectify or replace

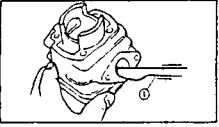

3. Eliminate:

- Carbon deposits ① ②
- From the crown of the piston and ring slots.

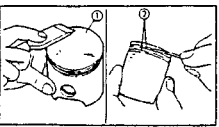

**SIGNAL SYSTEM** ELEC

• Turn the main switch to "ON".

• Place the "↔" switch at "→" or "←".

• Check the voltage (12 V) on the "Chocolate" or "Dark Green" wire from the socket connector

**OUT OF SPECIFICATION**

The connection circuit of the "TURN" switch at the socket connector is defective. replace it.

↓

**MEETS SPECIFICATION (12V)**

The circuit is in good condition.

4. The "OIL" indicator light does not light up.

1. Bulb and socket

- Check the bulb and socket to see if there is continuity.

**NO CONTINUITY**

Change the bulb and/or socket.

↓

**CONTINUITY**

2. Oil level switch

- Remove the oil level switch from the oil tank.
- Connect the pocket tester (Lx1) to the oil level switch.

Tester cable (+) → Terminal ①  
Tester cable (-) → Terminal ②

- Check the oil level gauge for continuity.

Position of switch	Good condition	Poor condition
A Position straight upward	x	o x o
B Position backwards	o	x x o
o: Continuity	x: No continuity	

**POOR CONDITION**

Change the oil level switch.

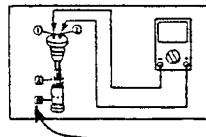

⑧

---

• If it is out of specification, rectify or replace the cylinder. Replace the piston and piston rings together.

Second case:

- Measure the diameter of the skirt of piston "P" with a micrometer.
- ③ 5.0 mm. (0.20 in.) from the lower edge of the piston.

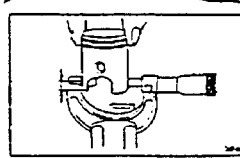

⑦



## SYMBOLS

The following symbols are not relevant to every vehicle.

Symbols ① to ⑨ indicate the subject of each chapter.

- ① General information
- ② Specifications
- ③ Periodic checks and adjustments
- ④ Chassis
- ⑤ Engine
- ⑥ Cooling system
- ⑦ Carburetor(s)
- ⑧ Electrical system
- ⑨ Troubleshooting

Symbols ⑩ to ⑰ indicate the following.

















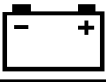





- ⑩ Serviceable with engine mounted
- ⑪ Filling fluid
- ⑫ Lubricant
- ⑬ Special tool
- ⑭ Tightening torque
- ⑮ Wear limit, clearance
- ⑯ Engine speed
- ⑰ Electrical data

Symbols ⑱ to ⑳ in the exploded diagrams indicate the types of lubricants and lubrication points.









- ⑱ Engine oil
- ⑲ Gear oil
- ⑳ Molybdenum-disulfide oil
- ㉑ Wheel-bearing grease
- ㉒ Lithium-soap-based grease
- ㉓ Molybdenum-disulfide grease

Symbols ㉔ to ㉕ in the exploded diagrams indicate the following.

- ㉔ Apply locking agent (LOCTITE®)
- ㉕ Replace the part

① GEN INFO 	② SPEC 	
③ CHK ADJ 	④ CHAS 	
⑤ ENG 	⑥ COOL 	
⑦ CARB 	⑧ ELEC 	
⑨ TRBL SHTG ?	⑩ 	
⑪ 	⑫ 	
⑬ 	⑭ 	
⑮ 	⑯ 	⑰ 
⑱ 	⑲ 	⑳ 
㉑ 	㉒ 	㉓ 
㉔ 	㉕ New	

# TABLE OF CONTENTS

<b>GENERAL INFORMATION</b>	
	<b>GEN INFO 1</b>
<b>SPECIFICATIONS</b>	
	<b>SPEC 2</b>
<b>PERIODIC CHECKS AND ADJUSTMENTS</b>	
	<b>CHK ADJ 3</b>
<b>CHASSIS</b>	
	<b>CHAS 4</b>
<b>ENGINE</b>	
	<b>ENG 5</b>
<b>COOLING SYSTEM</b>	
	<b>COOL 6</b>
<b>CARBURETOR</b>	
	<b>CARB 7</b>
<b>ELECTRICAL SYSTEM</b>	
	<b>ELEC 8</b>
<b>TROUBLESHOOTING</b>	<b>?</b>
	<b>TRBL SHTG 9</b>



# GEN INFO

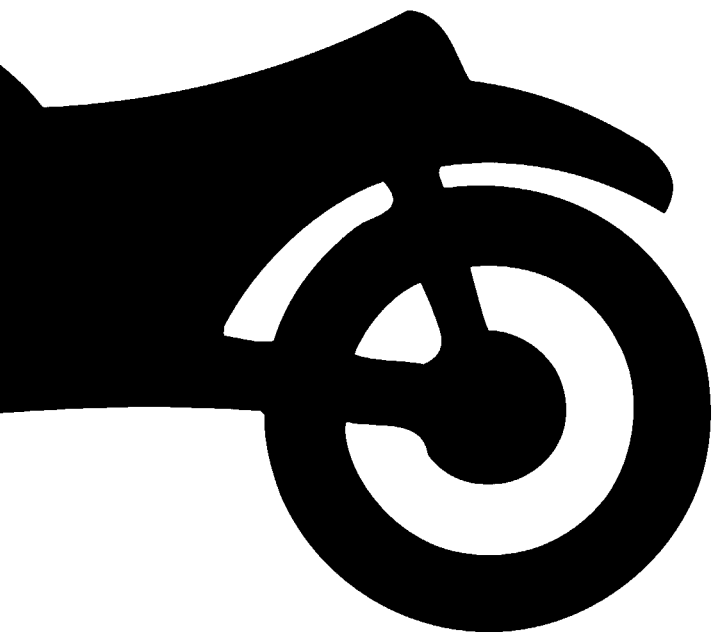

---

## CHAPTER 1 GENERAL INFORMATION

<b>MOTORCYCLE IDENTIFICATION</b> .....	1-1
FRAME SERIAL NUMBER .....	1-1
ENGINE SERIAL NUMBER.....	1-1
<b>IMPORTANT INFORMATION</b> .....	1-2
PREPARATION FOR REMOVAL .....	1-2
ALL REPLACEMENT PARTS .....	1-2
GASKETS, OIL SEALS AND O-RINGS .....	1-2
LOCK WASHERS/PLATES AND COTTER PINS.....	1-2
BEARINGS AND OIL SEALS .....	1-3
CIRCLIP.....	1-3
CHECKING THE CONNECTIONS.....	1-4
<b>SPECIAL TOOLS</b> .....	1-5

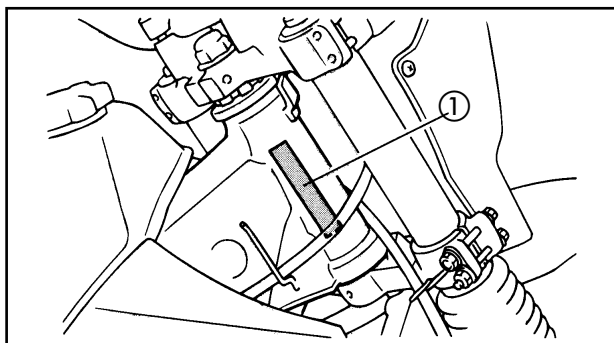

EAS00014

## GENERAL INFORMATION MOTORCYCLE IDENTIFICATION

### FRAME SERIAL NUMBER

The frame IDENTIFICATION number ① is stamped onto the steering head pipe.

**NOTE:** \_\_\_\_\_

The frame serial number is used to identify the motorcycle and therefore it can be used for the enrollment in the face of the competent authority.

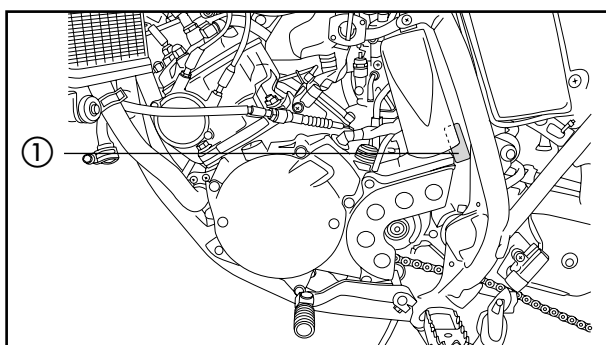

### ENGINE SERIAL NUMBER

The engine serial number ① is stamped onto the left side of the crankcase.

**NOTE:** \_\_\_\_\_

The first three digits of this number identifies “the model; the other digits indicate the number” of production of the unit.

**NOTE:** \_\_\_\_\_

Design and specifications may change without notice.

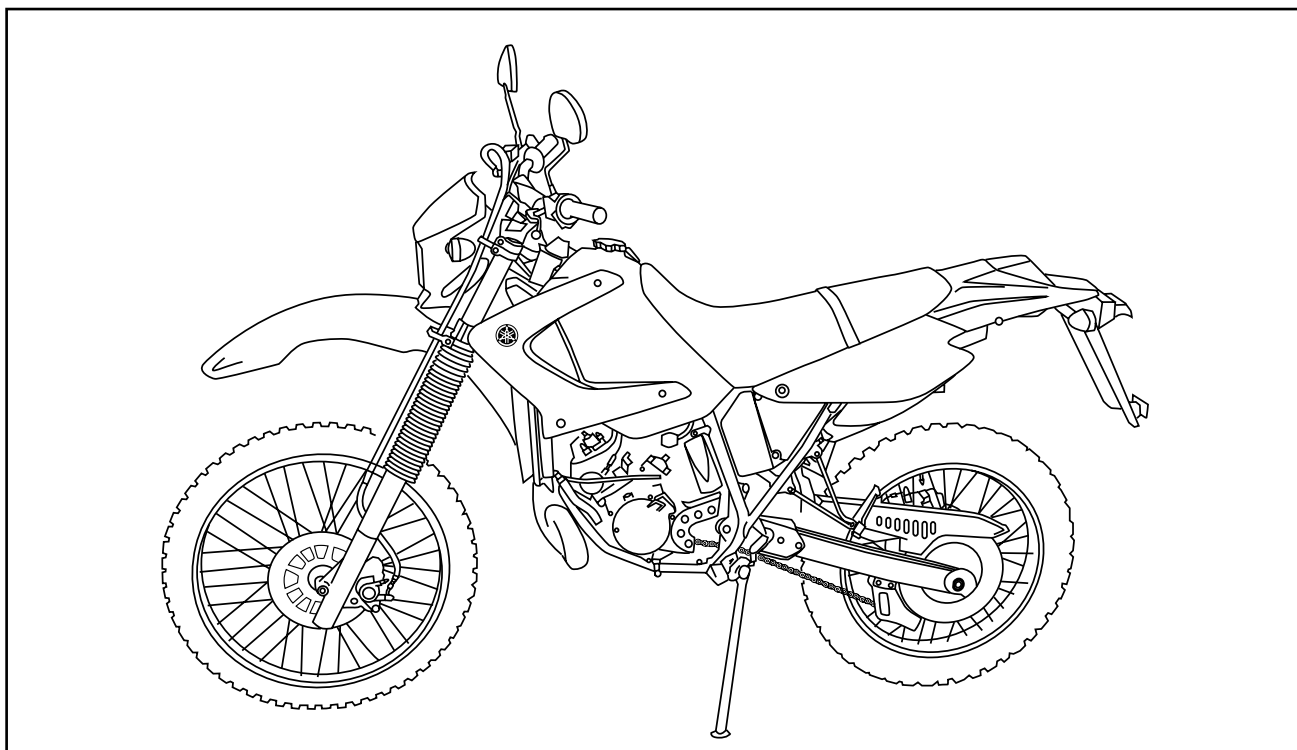

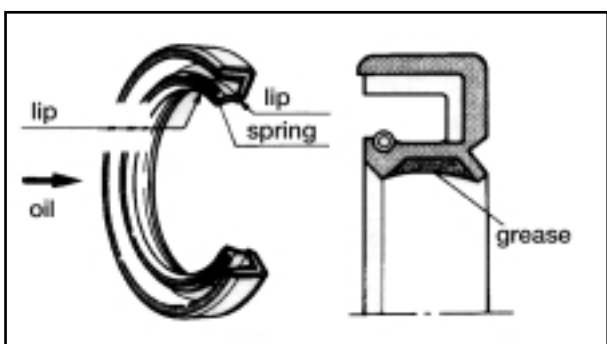
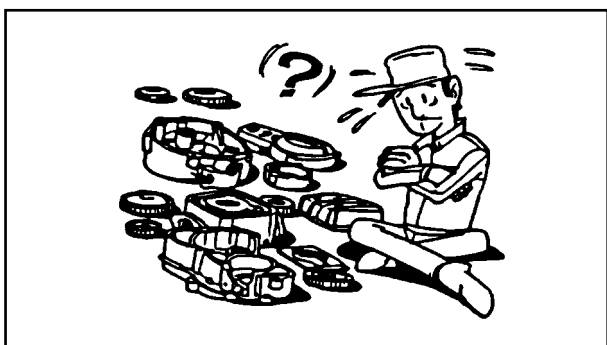

## IMPORTANT INFORMATION

### PREPARATION FOR REMOVAL AND DISASSEMBLY

1. Before removal and disassembly, remove all dirt, mud, dust and foreign material.
2. Use only the proper tools and cleaning equipment. Refer to the "SPECIAL TOOLS".
3. When disassembling, always keep mated parts together. This includes gears, cylinders, pistons and other parts that have been "mated" through normal wear. Mated parts must always be reused or replaced as an assembly.
4. During disassembly, clean all of the parts and place them in trays in the order of disassembly. This will speed up assembly and allow for the correct installation of all parts.
5. Keep all parts away from any source of fire.

EAS00021

### REPLACEMENT PARTS

Use only genuine Yamaha parts for all replacements. Use oil and grease recommended by Yamaha for all lubrication jobs. Other brands may be similar in function and appearance, but inferior in quality.

EAS00022

### GASKETS, OIL SEALS AND O-RINGS

1. When overhauling the engine, replace all gaskets, seals and O-rings. All gasket surfaces, oil seal lips and O-rings must be cleaned.
2. During reassembly, properly oil all mating parts and bearings and lubricate the oil seal lips with grease.

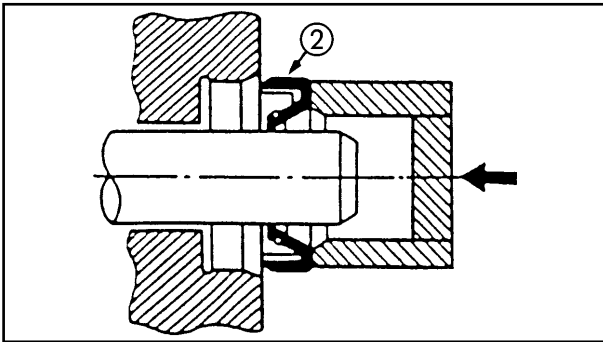

EAS00024

## BEARINGS AND OIL SEALS

Install bearings and oil seals so that the manufacturer's marks or numbers are visible. When installing oil seals, lubricate the oil seal lips with a light coat of lithium-soap-based grease. Oil bearings liberally when installing, if appropriate.

② Oil seal

### CAUTION

**Do not spin the bearing with compressed air because this will damage the bearing surfaces.**

① Bearing

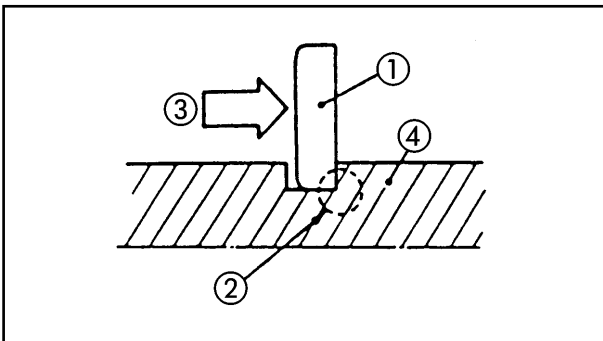
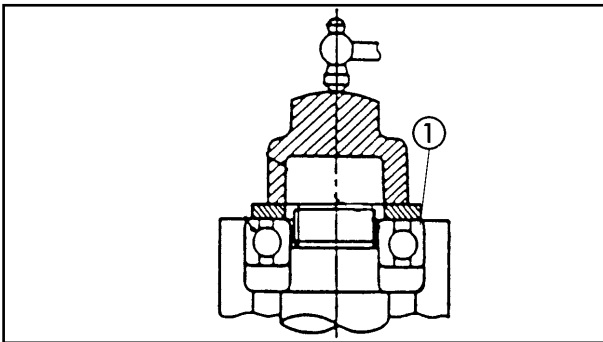

EAS00025

## CIRCLIPS

Before reassembly, check all circlips carefully and replace damaged or distorted circlips. Always replace piston pin clips after one use. When installing a circlip ①, make sure the sharp-edged corner ② is positioned opposite the thrust ③ that the circlip receives.

④ Shaft



## CHECKING THE CONNECTIONS

**GEN  
INFO**

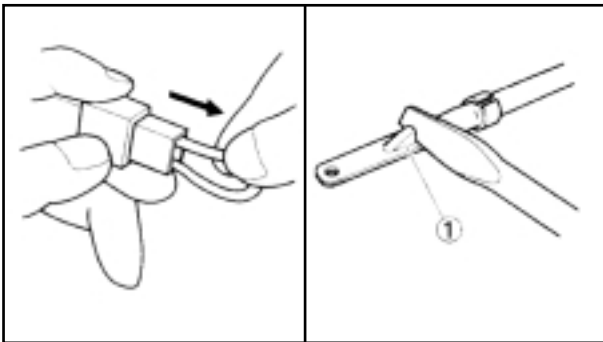
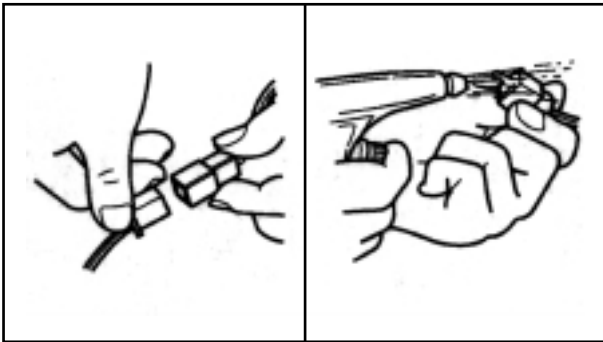

EAS00026

### CHECKING THE CONNECTIONS

Check the leads, couplers, and connectors for stains, rust, moisture, etc.

1. Disconnect:

- lead
- coupler
- connector

2. Check:

- lead
- coupler
- connector

Moisture → Dry with an air blower.

Rust/stains → Connect and disconnect several times.

3. Check:

- all connections

Loose connection → Connect properly.

**NOTE:** \_\_\_\_\_

If the pin ① on the terminal is flattened, bend it up.

4. Connect:

- lead
- coupler
- connector

**NOTE:** \_\_\_\_\_

Make sure all connections are tight.

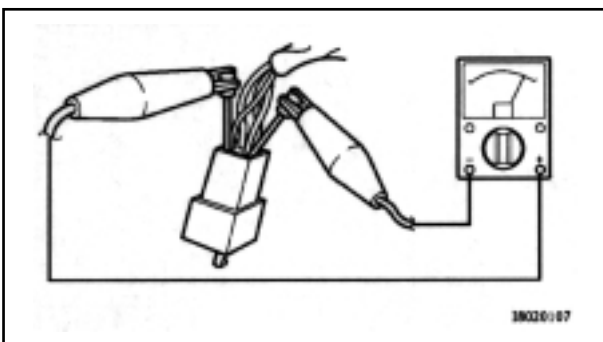
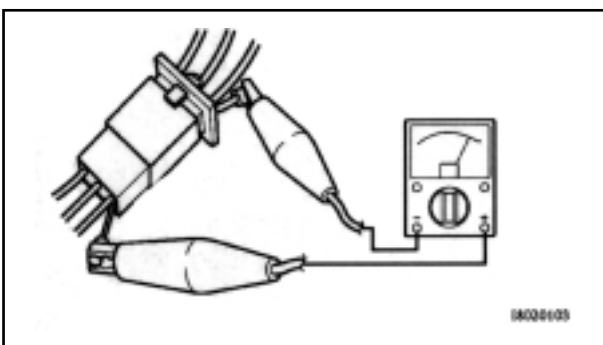

5. Check:

- continuity  
(with the pocket tester)



**Pocket tester**  
90890-03112, YU-3112

**NOTE:** \_\_\_\_\_

- If there is no continuity, clean the terminals.
- When checking the wire harness, perform steps (1) to (3).
- As a quick remedy, use a contact revitalizer available at most part stores.

EAS00027

## SPECIAL TOOLS

The following special tools are necessary for complete and accurate tune-up and assembly. Use only the appropriate special tools as this will help prevent damage caused by the use of inappropriate tools or improvised techniques. Special tools, part numbers or both may differ depending on the country.

When placing an order, refer to the list provided below to avoid any mistakes.

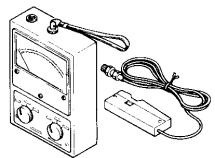
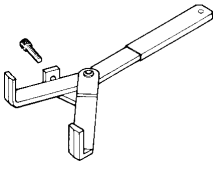
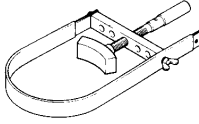
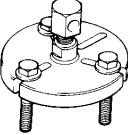
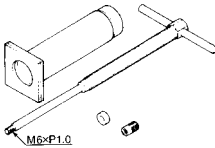
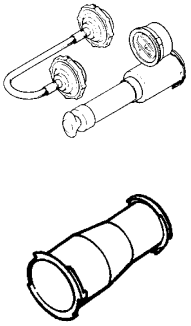
Tool No.	Tool name / Usage	Illustration
90890-01312	Fuel level gauge  This gauge is used to measure the fuel level in the float chamber.	
90890-03113	Engine tachometer  This tool is needed for detecting engine rpm.	
90890-04086	Universal tool of subjection of the clutch  This tool is used to immobilize the clutch during the assembly or disassembly of the blockade nut of the clutch.	
90890-01701	Sheave holder  This tool is used for holding the secondary sheave.	
90890-01362	Flywheel puller  For removing the flywheel.	
90890-01304	Piston pin puller  This tool is used to remove the piston pin.	
90890-01325 90890-01352	Radiator cap tester Adaptor  These tools are used for checking the cooling system.	

## SPECIAL TOOLS

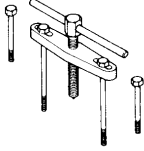
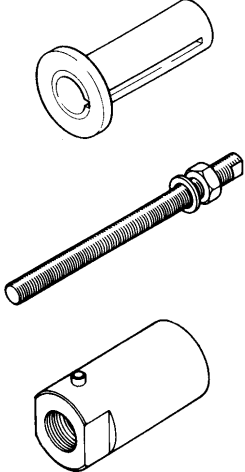
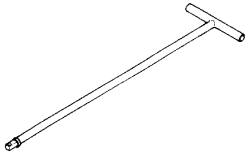
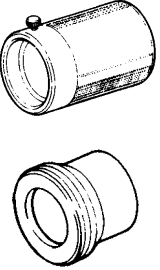
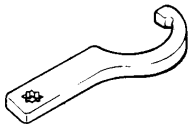
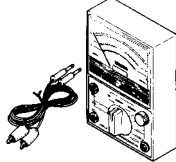

Tool No.	Tool name / Usage	Illustration
90890-01135	<p>Crankcase separation tool</p> <p>This tool is used to remove the crankshaft or separate the crankcase.</p>	
90890-01274 (1) -01275 (2) -01278 (3)	<p>Crankshaft installing tool Crankshaft pin Adapter(M12)</p>	
90890-01326	<p>T-Handle</p> <p>This tool is used for holding the damper rod holder when removing or installing the damper rod holder.</p>	
90890-01367 -01381	<p>Fork seal driver weight Fork seal driver attachment</p> <p>This tool is used when installing the fork seal.</p>	
90890-01403	<p>Ring nut wrench</p> <p>This tool is used to loosen and tighten the steering ring nut.</p>	
90890-03112	<p>Pocket tester</p> <p>These instruments are invaluable for checking the electrical system.</p>	



**U**

**SPEC**

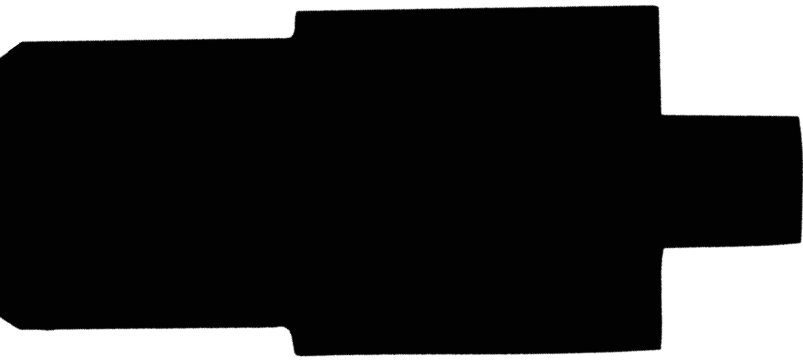

2

[www.legends-yamaha-enduros.com](http://www.legends-yamaha-enduros.com)



---

## CHAPTER 2 SPECIFICATIONS

<b>GENERAL SPECIFICATIONS</b> .....	2-1
ENGINE SPECIFICATIONS.....	2-4
CHASSIS SPECIFICATIONS .....	2-6
ELECTRICAL SPECIFICATIONS .....	2-8
<b>CONVERSION TABLE</b> .....	2-10
<b>GENERAL TIGHTENING TORQUE SPECIFICATIONS</b> .....	2-10
ENGINE .....	2-11
CHASSIS .....	2-11
<b>COOLANT FLOW CHART</b> .....	2-13
<b>LUBRICATION POINTS AND LUBRICANT TYPE</b> .....	2-14
ENGINE .....	2-14
CHASSIS.....	2-15
<b>CABLE ROUTING</b> .....	2-16



## SPECIFICATIONS

## GENERAL SPECIFICATIONS

Model	DT125RE	DT125X
<b>Model code</b>	1D01/1D02	2C81
<b>Dimensions:</b>		
Overall length	2210mm	2139mm
Overall width	795mm	1121mm
Overall height	1200mm	1200mm
Seat height	900mm	886mm
Wheelbase	1415mm	1396mm
Minimum ground clearance	300mm	271 mm
Minimum turning radius	2100mm	2016mm
<b>Basic weight:</b>		
With oil and full fuel tank	126kg	134 kg
<b>Engine:</b>		
Engine type:	2 strokes, liquid cooled	
Induction system	Reed valve	
Cylinder arrangement	Forward-inclined single cylinder	
Displacement	124cm <sup>3</sup>	
BorexStroke	56,0x50,7	
Compression ratio	6,7:1	
Maximum power	11kW /8000rpm	
Maximum torque	13Nm/8000rpm	
Idle speed	1250~1450r/min	
Starting system	Electric starter	
Lubrication system	Yamaha Autolube	
<b>Oil type or grade:</b>		
Engine oil	2T motor oil (JASO grade FC)	
Total amount	1,3L	
Transmission oil	Type SE motor oil	
Periodic oil change	0,75L (0,79 us. qt.)	
Total amount	0,8L (0,85 us.qt.)	
<b>Radiator capacity:</b>		
Total amount (including all routes)	0,92L	
Coolant reservoir capacity	0,30L	
<b>Air filter:</b>	Wet type element	
<b>Fuel</b>		
Type	Regular unleaded gasoline	
<b>Fuel tank capacity:</b>		
Reserve	10,7L	1,8L
<b>Carburetor:</b>		
Type/quantity	TM28-92 / 1	
Manufacturer:	MIKUNI	



## GENERAL SPECIFICATIONS

**SPEC**



<b>Model code</b>	1D01/1D02	2C81
<b>Spark plug:</b> Type Manufacturer Spark plug gap	BR8ES NGK 0,7~0,8mm (0,0276~0,03315in)	
<b>Clutch type</b>	Wet, multiple disc	
<b>Transmission:</b> Primary reduction system Primary reduction ratio Secondary reduction system Secondary reduction ratio Transmission type Operation	Helical gear 71/22(3,227) chain drive 57/16(3,563) Constant mesh, 6 speed Left foot operation	
<b>Gear ratio:</b> 1 <sup>a</sup> 2 <sup>a</sup> 3 <sup>a</sup> 4 <sup>a</sup> 5 <sup>a</sup> 6 <sup>a</sup>	34/12(2.833) 30/16(1.875) 24/17(1.412) 24/21(1.143) 22/23(0.957) 18/22(0.818)	
<b>Chassis:</b> Frame type: Castor angle Trail	Semi double cradle 27° 107mm	Semi double cradle 24,5° 73,1 mm
<b>Tire:</b> Type Size Front Rear Manufacturer	With tube  80/90-21 48P 110/80-18 58P Michelin /T63	With tube  120/70-17 58H 140/70-17 66H Pirelli/ Sport Demon
<b>Cold tire pressure:</b> Front Rear Front Rear	0~90kg 0~90kg 90~178kg 90~178kg	150kPa (1.5kgf/cm <sup>2</sup> ) 175kPa (1.75kgf/cm <sup>2</sup> ) 175kPa (1.75kgf/cm <sup>2</sup> ) 200kPa (2.0kgf/cm <sup>2</sup> )
<b>Off road riding:</b> Front Rear	150kPa (1.5kgf/cm <sup>2</sup> ) 175kPa(1.75kgf/cm <sup>2</sup> )	
<b>Brakes:</b> Front brake type  Front brake operation Rear brake type  Rear brake operation	Single disc brake 230mm diameter Right hand operation Single disc brake 220mm diameter Right foot operation	Single disc brake 298 mm diameter Right hand operation Single disc brake 220 mm diameter Right foot operation
<b>Suspensions:</b> Front Rear	Telescopic fork Swingarm (monocross suspension)	
<b>Shock absorber:</b> Front Rear	Coil-air spring/Oil damper Coil and gas spring/Oil damper	

## GENERAL SPECIFICATIONS

**SPEC**



<b>Model code</b>	1D01/1D02	2C81
<b>Wheel travel:</b> Front wheel travel Rear wheel travel	270mm(10.63in) 260mm(10.24in)	200mm (7,87in) 230mm (9.05in)
<b>Electrical:</b> Ignition system Charging system Battery type Capacity	CDI AC Magneto GT6B-3 12V 6Ah	
<b>Headlight:</b>	bulb type	
<b>Bulb wattage x quantity:</b> Headlight Tail/Brake light Turn signal indicator light  Front Rear  Meter	12V60W/55W x 1 12V21W/5W x 1  12V10W x 1 12V10W x 1 LED	
<b>Control lights:</b> "OIL" "TURN" "NEUTRAL" "HIGH BEAM" "LOW BEAM"	12V3W X 1 12V3W X 1 12V3W X 1 12V3W X 1 12V3W X 1	
<b>Amperages:</b> Principal fuse	15A	

# GENERAL SPECIFICATIONS

SPEC

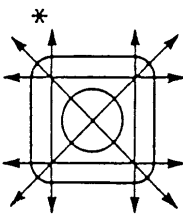
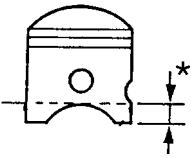
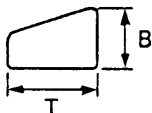

## ENGINE

Item	Standard	Limit
<b>Cylinder head:</b> Warpage limit <div style="text-align: center; margin-top: 10px;">  </div>	* Lines indicate straightedge measurement.	0,03mm
<b>Cylinder:</b> Bore size Taper limit Out of round limit	56.00~56.02mm 0.05mm 0.01mm	*** *** ***
<b>Piston:</b> Piston size "D" Measurement point* Piston to cylinder clearance Piston Offset <div style="text-align: center; margin-top: 10px;">  </div>	55.950~55.955 10mm 0.045~0.050mm 0.5mm	*** *** 0.10mm ***
<b>Piston ring:</b> Type Dimensions(BxT): Top ring 2nd ring End gap (installed): Top ring 2nd ring Side clearance: Top ring 2nd ring <div style="text-align: center; margin-top: 10px;">  </div>	Keystone * 1.2x2.4mm 1.20x1.89mm * 0.30~0.45mm 0.30~0.45mm * 0.02~0.06mm 0.035~0.070mm	*** * *** *** * *** *** * *** ***
<b>Cooling system:</b> Radiator capacity (including all routes) Reservoir tank capacity Radiator cap opening pressure  Radiator core width Radiator core height Radiator core thickness Water pump type	0.92L 0.3L 75~105kPa (0.75~1.05kgf/cm2) 110mm 280mm 32mm Single-suction centrifugal pump	*** * *** *** *** ***

## GENERAL SPECIFICATIONS

**SPEC**



Item	Standard	Limit
<p><b>Crankshaft:</b></p> <div style="display: flex; align-items: center;"> <div style="flex: 1;"> <p>Crank width "A" Runout limit "C" Big end side clearance ' Small end free play "E"</p> </div> <div style="flex: 0.5; text-align: center;"> </div> </div>	<p>57.90~57.95mm *** 0.2~0.7mm 0.026~0.040mm</p>	<p>*** 0.03mm *** ***</p>
<p><b>Clutch:</b></p> <p>Friction plate thickness Quantity Clutch plate thickness Quantity Clutch spring Free lenght Quantity Minimum free lenght Push rod bending limit</p>	<p>2.9~3.1mm 7pcs 1.05~1.35mm 6pcs 34.5mm 5pcs 32mm 0.15mm</p>	<p>2.7mm *** 0.05mm *** *** *** *** ***</p>
<p><b>Transmission:</b></p> <p>Main axle runout limit Drive axle runout limit</p>	<p>*** ***</p>	<p>0.08mm 0.08mm</p>
<p><b>Carburetor:</b></p> <p>Type ID Mark Main jet Air jet Jet Needle position Needle jet Pilot outlet Pilot jet Bypass1 Air screw turns Valve seat size Starter jet 1 Power jet Float height Fuel level Idling speed</p>	<p>TM28-92/1 1DO #210 0.7 5J40-2 Q2M (#939) 0.6 #17.5 1.6 1/4 2.8 #40 #60 15.5~16.5mm 1.5~2.5mm 1250~1450r.p.m</p>	<p>*** *** *** *** *** *** *** *** *** *** *** *** *** *** *** ***</p>
<p><b>Air filter:</b></p> <p>Type Oil type/grade</p>	<p>Wet element Foam air filter oil or SAE10W30SE</p>	<p>*** ***</p>
<p><b>Reed valve:</b></p> <p>Valve thickness Valve stopper height Valve bending limit</p>	<p>0.5mm 8.8mm 0.5mm</p>	<p>*** *** ***</p>
<p><b>Lubrication system:</b></p> <p>Autolube pump Color code Minimum stroke Maximum stroke Minimum output Maximum output Pulley adjusting mark</p>	<p>* Dark blue 0.15~0.20mm 1.85~2.05mm 0.38~0.50cm<sup>3</sup> 4.65~5.15cm<sup>3</sup> autoadjustable</p>	<p>* *** *** *** *** *** ***</p>

# GENERAL SPECIFICATIONS

**SPEC**



## CHASSIS

Item	Standard		Limit	
Model code	1D0	2C81	1D0	2C81
<b>Front wheel:</b> Type Rim Size Rim Material Front wheel travel: Max. Radial wheel runout Max. Lateral wheel runout	Spoke wheels 21x1.60 Steel 270mm 1mm 0.5mm	Spoke wheels 17 x 3.00 Steel 270mm 1mm 0.5mm		
<b>Rear wheel:</b> Type Rim size Rim material Rear wheel travel Max. Radial wheel runout Max. Lateral wheel runout	Spoke wheels 18x1.85 Steel 260mm(10.24in) 1mm(0.04in) 0.5mm(0.02in)	Spoke wheels 17x3.50 Steel 260mm(10.24in) 1mm(0.04in) 0.5mm(0.02in)		
<b>Front disc brake:</b> Thickness Brake pad lining thickness-inner Brake pad lining thickness-outer Master cylinder inside diameter Caliper cylinder inside diameter Recommended fluid	230.0x3.5mm 6mm 6 mm 11mm 34.93mm DOT 4	230.0x3.5mm 4.1mm 6 mm 11mm 34.93mm DOT 4	0.8mm 0.8mm	0.5mm 0.8mm
<b>Rear disc brake:</b> Thickness Brake pad lining thickness-inner Brake pad lining thickness-outer Master cylinder inside diameter Caliper cylinder inside diameter Recommended fluid	220.0x4.5mm 5.6mm 5.6mm 12.7mm 30.16mm DOT 4		1.0mm 1.0mm	
<b>Steering system:</b> Steering type  Bearing size (quantity) Upper	Ball and taper roller bearing  22pcs (0.1875in)			
<b>Front suspension:</b> Front fork travel Fork free length Spring rate K1 Spring stroke K1 Optional spring available Recommended oil Quantity Level	270mm 503mm 3.1N/mm 0~270mm No Fork oil 10W 495cm <sup>3</sup> 165.5mm	200 mm 503mm 3.1N/mm 0~270mm No Fork oil 10W 495cm <sup>3</sup> 165.5mm		

## GENERAL SPECIFICATIONS

**SPEC**



Item	Standard		Limit	
	1D0	2C81	1D0	2C81
<b>Model code</b>	1D0	2C81	1D0	2C81
<b>Rear suspension:</b>				
Type	Swingarm (link suspension)	Swingarm (link suspension)		
Rear shock absorber assembly travel	93mm	87 mm		
Spring free length	245mm	250mm		
Installed length	230mm	244mm		
Spring preload (spring length)	Hard/Soft (220/235mm)	Hard/Soft (234/249mm)		
Spring rate K1	68.6N/mm	117.80N/mm		
Spring stroke K1	0~93mm	0~87mm		
Optional spring available	No	No		
Enclosed gas/air pressure (STD)	150kPa (15kgf/cm <sup>2</sup> )	150kPa (15kgf/cm <sup>2</sup> )		
Tightening torque spring preload	20~25Nm	20~25Nm		
<b>Drive chain:</b>				
Type/Manufacturer	428V2/DAIDO	428V2/DAIDO		
Link quantity	134	134		
Drive chain slack	45~55mm (1.77~2.16in)	25~40mm (0.98~1.57in)		
<b>Front lever brake/Rear brake pedal:</b>				
Free play front lever brake	2~5mm			
Brake pedal free play	15mm			

## GENERAL SPECIFICATIONS

**GEN  
INFO**



### ELECTRICAL

Model	1D01/1D02	2C81
<b>System voltage</b>	12 V	
<b>Ignition system:</b> Ignition system type Ignition timing (B.T.D.C.) ((°)) Advancer type	C.D.I. 17 /1500r/min Digital	
<b>C.D.I.:</b> Magneto model/manufacturer Pick up coil resistance((ohm)) Source coil resistance ((ohm)) Source coil resistance ((ohm)) CDI unit model/manufacturer	F4FU/YAMAHA 310±20%W/R-W/L 730±20%B/R-G/W 600±20%G/L-G/W 1D0 /YAMAHA	
<b>Ignition coil:</b> Model/Manufacturer Primary coil resistance ((ohm)) Secondary coil resistance ((ohm))	3RW/YAMAHA 0.23±20% 7.9±20%	
<b>Spark plug cap:</b> Material Resistance ((k ohm))	Resin 5	
<b>A.C. Magneto:</b> Model/Manufacturer Standard output Coil resistance ((ohm))	F4FU/YAMAHA 14V170W5000r/min 0.6±20%W-W	
<b>Regulator:</b> Regulator type Model/Manufacturer No load regulated voltage	Semi conductor-short circuit SH629B-11/SHINDENGEN 14.1~14.9V	
<b>Rectifier:</b> Rectifier capacity Withstand voltage	25A 200V	
<b>Battery:</b> Battery type Battery voltage/Capacity	GT6B-3 12V6Ah	
<b>Bulbs (voltage/wattage x quantity)</b> Headlight type Headlight bulb type Headlight Auxiliary light Brake/tail light Front flasher light Rear flasher light Meter light	Bulb type Halogen H4 12V60W/55Wx1 12V5Wx1 12V21W/5Wx1 12V10Wx2 12V10Wx2 LED	

## GENERAL SPECIFICATIONS

**GEN  
INFO**



<b>Indicator light</b> Neutral indicator light Turn indicator light Oil level indicator light High beam indicator light	12V3Wx1 12V3Wx1 12V3Wx1 12V3Wx1
<b>Starting system:</b> System type	Electric starter
<b>Starter motor:</b> Model/Manufacturer Power output Armature coil resistance Brush overall length <Limit> Brush spring force <Limit> Commutator diameter <Limit> Mica undercut (depth)	3MB / Moric 0.2kW 0.0315~0.0385<ohm> 20°C 5X7X7 3,5 4.9N ±20% 3.92N 17.6mm 16.6mm 1.35mm
<b>Starter relay:</b> Model/Manufacturer Amperage Coil resistance	1D0/JIDECO 180A 4.2 - 4.6<ohm> 20°C
<b>Horn:</b> Horn type Quantity Model/Manufacturer Max. Amperage Performance	Plane 1 YF-12/NIKKO 3A 105~113db/2m
<b>Turn signal relay:</b> Relay type Model/Manufacturer Turn signal blinking frequency Wattage	Full transistor FE218BH/DENSO 75~95cyl/min 10Wx2+3.4W
<b>Oil level gauge:</b> Model/Manufacturer	3XP/ASTI
<b>Starting circuit cut-off relay:</b> Model/Manufacturer Coil resistance	25G/OMRON 100<ohm>±10%
<b>Headlight relay:</b> Model/Manufacturer Coil resistance	25G/OMRON 100<ohm>±10%
<b>Side stand relay:</b>	BUILT IN CUT OFF RELAY
<b>Thermostat switch:</b> Model/Manufacturer Temperature setting	4BA/DENSO 120±3<degree>
<b>Servo motor:</b> Model/Manufacturer	3XP/MATSUSHITA
<b>Amperage for fuses:</b> Main fuse Spare fuse	15A 15A



# CONVERSION TABLE / GENERAL TIGHTENING TORQUES SPECIFICATIONS



EAS00028

## CONVERSION TABLE

All specification data in this manual are listed in SI and METRIC UNITS. Use this table to convert METRIC unit data to IMPERIAL unit data.

Ex.

METRIC	MULTIPLIER	IMPERIAL
** mm	x 0.03937	= ** in
2 mm	x 0.03937	= 0.08 in

### CONVERSION TABLE

METRIC TO IMPERIAL			
	Metric unit	Multiplier	Imperial unit
Tightening Torque	m•kg	7.233	ft•lb
	m•kg	86.794	in•lb
	cm•kg	0.0723	ft•lb
	cm•kg	0.8679	in•lb
Weight	kg	2.205	lb
	g	0.03527	oz
Speed	km/hr	0.6214	mph
Distance	km	0.6214	mi
	m	3.281	ft
	m	1.094	yd
	cm	0.3937	in
	mm	0.03937	in
Volume, Capacity	cc (cm <sup>3</sup> )	0.03527	oz (IMP liq.)
	cc (cm <sup>3</sup> )	0.06102	cu•in
	lt (liter)	0.8799	qt (IMP liq.)
	lt (liter)	0.2199	gal (IMP liq.)
Misc.	kg/mm	55.997	lb/in
	kg/cm <sup>2</sup>	14.2234	psi (lb/in <sup>2</sup> )
	Centigrade (°C)	9/5 + 32	Fahrenheit (°F)

EAS00029

## GENERAL TIGHTENING TORQUE SPECIFICATIONS

This chart specifies tightening torques for standard fasteners with a standard ISO thread pitch. Tightening torque specifications for special components or assemblies are provided for each chapter of this manual. To avoid warpage, tighten multi-fastener assemblies in a crisscross pattern and progressive stages until the specified tightening torque is reached. Unless otherwise specified, tightening torque specifications require clean, dry threads. Components should be at room temperature.

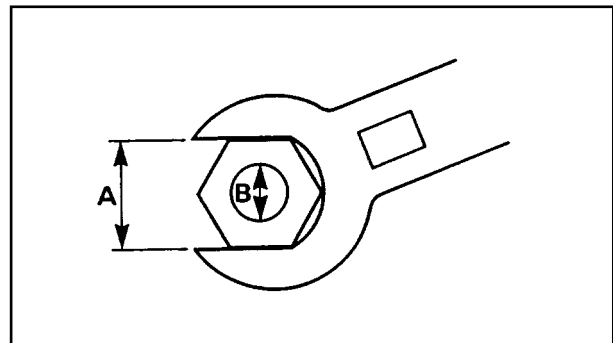



**A:** Width across flats  
**B:** Thread diameter

A (nut)	B (bolt)	General tightening torques	
		Nm	m • kg
10 mm	6 mm	6	0.6
12 mm	8 mm	15	1.5
14 mm	10 mm	30	3.0
17 mm	12 mm	55	5.5
19 mm	14 mm	85	8.5
22 mm	16 mm	130	13.0



## TIGHTENING TORQUES ENGINE

Part to be tightened		Q'ty	Thread size	Tightening torque		Remarks
				Nm	m•kg	
Spark plug		1	M14x1.25	20	2,0	
Cylinder head	Nut	5	M8x1.25	22	2,2	
Cylinder	Stud bolt	9	M8X1.25	13	1,3	LOCTITE screw glue 
	Nut	4	M8x1.25	28	2,8	
Power valve holder, Valve cover	Cap seal					
	Bolt	6	M5x0.8	7	0,7	
Power valve pully	Bolt		M6x1.0	10	1,0	
Thermostat valve cover	Screw	3	M6x1.0	8	0,8	
Housing cover	Screw	2	M6x1.0	8	0,8	
	Drain bolt (Housing cover)	1	M6x1.0	10	1	
Radiator	Bolt	2	M6x1.0	8	0,8	
Radiator cap stopper	Screw	1	M5x0.8	5	0,5	
Oil pump	Screw	2	M5x0.8	5	0,5	
Carburetor joint	Bolt	4	M6x1.0	8	0,8	
Air filter	Screw	2	M6x1.0	5	0,5	
Exhaust pipe	Nut	2	M8x1.25	18	1,8	LOCTITE screw glue 
	Stud bolt	2	M8x1.25	10	1	
	Bolt	3	M6x1.0	8	0,8	
Transmission Oil	Drain Bolt	1	M8x1.25	15	1,5	
Crankcase cover (left)	Screw	6	M6x1.0	5	0,5	
Crankcase cover (right)	Screw	6	M6x1.0	8	0,8	
Oil pump cover	Screw	3	M6x1.0	5	0,5	
Crankcase	Screw	12	M6x1.0	8	0,8	
Oil Seal Holder	Screw	1	M8x1.25	16	1,6	
Cover	Screw	2	M6x1.0	8	0,8	
Kick Crank Bass	Nut	1	M12X1.0	70	7	
Clutch Spring	Bolt	5	M5x0.8	6	0,6	
Plate cover	Screw	2	M6x1.0	10	1	
Drive Sprocket	Nut	1	M16X1.0	60	6	
Tachometer housing	Bolt	1	M6x1.0	5	0,5	
Stopper lever	Bolt	1	M6x1.0	14	1,4	LOCTITE screw glue 
Shift pedal	Bolt	1	M6x1.0	15	1,5	
Thermo unit						
Rotor	Nut	1	~	15	1,5	
		1	M12x1.25	80	8	

**CHASSIS**

Parts to be tightened	Thread size	Tightened torque		Remarks
		Nm	m•kg	
Engine stay (Top) and frame	M10	30-35	3,0-3,5	
Cylinder head stay (Top) and frame	M10	30-35	3,0-3,5	
Bottom screw (front) engine and frame	M10	60-78	6,0-7,8	
Bottom screw (front) engine to swingarm	M10	30-35	3,0-3,5	
Steering nut	M25	120-155	12,0-15,5	Steering must turn smoothly and without free play
Fuel cock lever	M6	5~8	0,5~0,8	
Upper bracket and meter holder	M6	5~8	0,5~0,8	
Rear bolt fuel tank to frame	M6	7,5-12	0,75-1,2	
Footrest security pins	—	Completely bend		
Front brake holder	M10	2~3	0,2~0,3	
Front brake pipe	M10	23-37	2,3-3,7	
Handlebar holder bolts to handlebars	M8	5~8	0,5~0,8	
Main switch	M6	7~12	0,7~1,2	Security allen bolt (with central pin)
Top holder bolts to suspension tubes	M8	12~28	1,2~2,8	
Sidestand nut	M8	20-32	2,0-3,2	
Rear brake lever	M8	7,5-12	0,75-1,2	
Rear master cylinder to holder	M6	7,5-12	0,75-1,2	
Brake pipe bolt	M10	23-37	2,3-3,7	
Security pin rear brake lever to pump	—	Completely bend		
Pivot shaft	M15	80-100	8,0-10,0	
Swingarm to connecting arm	M13	45-70	4,5-7,0	
Connecting arm relay arm	M13	45-70	4,5-7,0	
Relay arm to frame	M13	45-70	4,5-7,0	
Damper to frame	M10	30-35	3,0-3,5	
Damper to relay arm	M10	30-35	3,0-3,5	
Swingarm end bolts	—	2~4	0,2-0,4	
Driven sprocket	M8	32-37	3,2-3,7	
Rear wheel axle nut	M17	80-100	8,0-10,0	Check that the pin is bent
Front brake caliper to outer tube	M10	31-49	3,1-4,9	
Front wheel axle	M15	45-70	4,5-7,0	
Exhaust to cylinder head	M8	15-20	1,5-2,0	
Exhaust assy 1 to central exhaust pipe	M8	8~12	0,8-1,2	
Central exhaust pipe to muffler	M8	8~12	0,8-1,2	
Muffler and central pipe to frame holder	M8	38-42	3,8-4,2	
Clutch lever pivot nut	M6	5~8	0,5-0,8	
Front brake pivot lever nut	M6	5~8	0,5-0,8	
Front brake lever adjusting nut	M6	5~8	0,5-0,8	
Security nuts	M6	7,5-12	0,75-1,2	
Chain puller	M6	18-28	1,8-2,8	
shift shaft nut	M6	8~12	0,8-1,2	
Rear footrest holder	M8	17-22	1,7-2,2	
Bottom bolts inner holder to tube	M8	20-25	2,0-2,5	



COOLANT FLOW CHART

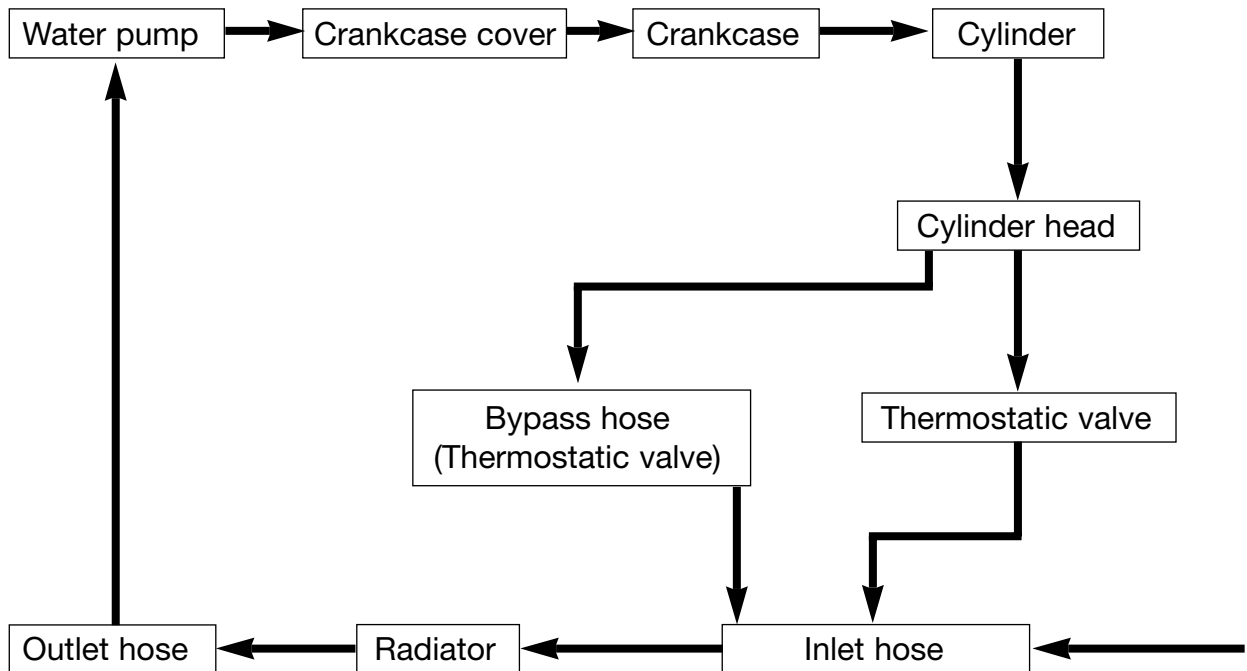
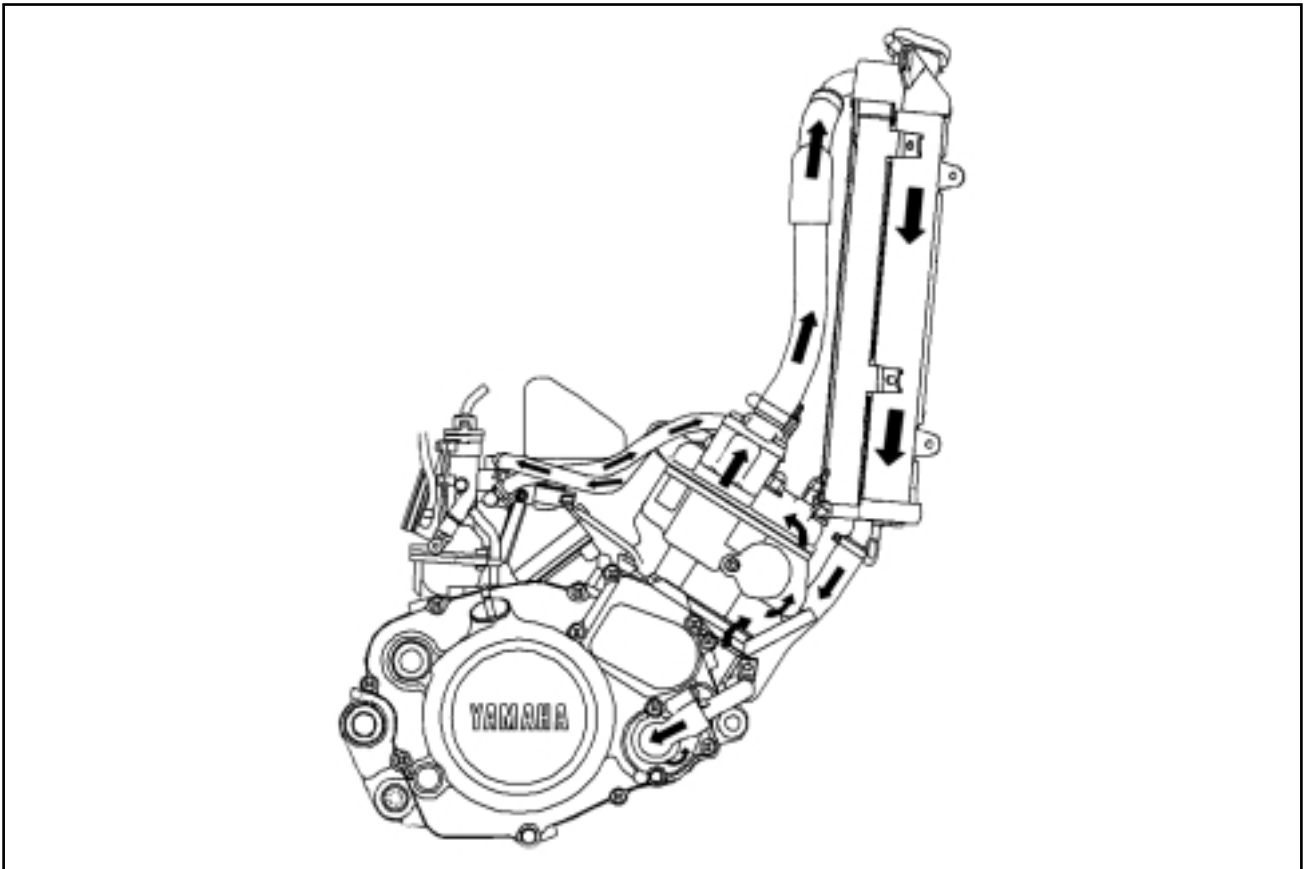

Coolant cold (Less than 65°C (149°F))  
Coolant hot (165°(149°F) or more)

# LUBRICATION POINTS AND LUBRICANT TYPES

SPEC



EAS00031

## ENGINE

Lubrication points (part name)	Lubricant Type
Oil seal lips (All)	Apply lightweight lithium-soap base grease 
O-Rings (All)	Apply lightweight lithium-soap base grease 
Bearing retainer	
Crankshaft bearings (Left and center)	Apply engine oil 
Needle bearings (Connecting rod)	Apply engine oil 
Main axle bearings	Apply gear oil 
Drive axle bearings	Apply gear oil 
Push lever bearings	Apply gear oil 
Crank pins	Apply engine oil 
Piston rings - piston pins and pistons	Apply engine oil 
Power valve holder	Apply lightweight lithium-soap base grease 
Impeller shaft (water pump)	Apply gear oil 
Warm shaft (Autolube pump)	Apply engine oil 
Kick idle gear	Apply gear oil 
Kick axle	Apply gear oil 
Primary driven gear (clutch housing)	Apply gear oil 
Push rod	Apply gear oil 
Push lever axle	Apply gear oil 
Sliding gear (Transmission)	Apply molybdenum disulfide grease 
Free movement gear (Transmission)	Apply molybdenum disulfide grease 
Guide bar (Shift forks)	Apply gear oil 
Crankcase mating surfaces	Yamaha bond no.4

# LUBRICATION POINTS AND LUBRICANT TYPES

SPEC



EAS00032

## CHASSIS

Lubrication points (part name)	Lubricant Type
Ball bearing (Steering shaft)	Apply lightweight lithium-soap base grease 
Bearing (Steering shafts)	Apply lightweight lithium-soap base grease 
Oil seal clutch to lever	Apply lightweight lithium-soap base grease 
Clutch lever axle free play	Apply lightweight lithium-soap base grease 
Throttle guide bar	Apply lightweight lithium-soap base grease 
Oil seal throttle wire to guide	Apply lightweight lithium-soap base grease 
Front brake lever axle free play	Apply lightweight lithium-soap base grease 
Footrests free play	Apply lightweight lithium-soap base grease 
Rear footrests free play (ball and axle)	Apply lightweight lithium-soap base grease 
Swingarm axle to frame	Apply lightweight lithium-soap base grease 
Relay arm to swingarm	Apply lightweight lithium-soap base grease 
Connecting rods	Apply lightweight lithium-soap base grease 
Engine holder to cylinder head	Apply lightweight lithium-soap base grease 
Rear brake lever pivot	Apply lightweight lithium-soap base grease 
Sidestand pivot	Apply lightweight lithium-soap base grease 
Oil seal lip (front wheel)	Apply lightweight lithium-soap base grease 
Front wheel axle outer surface	Apply lightweight lithium-soap base grease 
Oil seal lip (rear wheel)	Apply lightweight lithium-soap base grease 
Rear wheel axle outer surface	Apply lightweight lithium-soap base grease 



CABLE ROUTING

- ① Clutch wire
- ② Right turn signal lead
- ③ Left turn signal lead
- ④ Throttle cable
- ⑤ Indicator light wire lead
- ⑥ Meter wire lead
- ⑦ Headlight bulb wire
- ⑧ Handle wire lead (right)

- [A] Cover with cap after connecting wires.
- [B] Route the installation between lower bracket and headlight bottom holder.
- [C] Clamp connection wire.

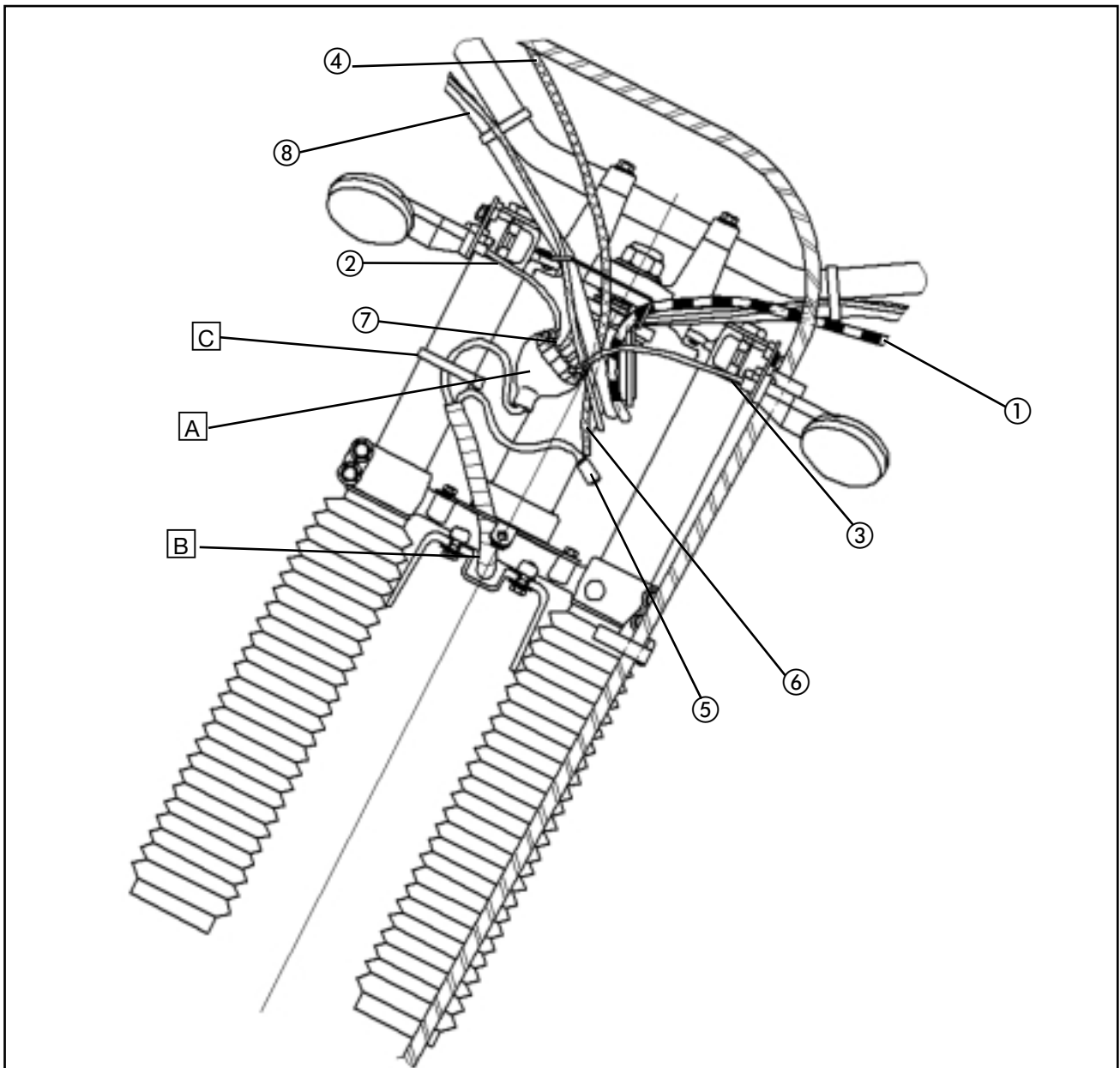



CABLE ROUTING

- ① Master cylinder
- ② Front brake hose
- ③ Wire throttle
- ④ Clutch sw wire lead
- ⑤ SW handle wire lead (left)
- ⑥ Clip
- ⑦ A.I.S.
- ⑧ Pipe overflow
- ⑨ Pipe to air filter
- ⑩ Pipe I
- ⑪ License light wire lead
- ⑫ Oil gauge

- [A] Turn the hose to obtain the desired angle.
- [B] Route clutch wire first for the inside, after route the throttle wire.
- [C] Clamp handle wire lead (L).
- [D] Clamp handle wire lead (R).
- [E] Clamp pipe overflow to the frame clamp.
- [F] Hold hoses on chassis clamp.
- [G] Cover with cap after connecting wires.
- [H] Route brake/tail light wire through rear mudguard hole.
- [I] Clamp rear turning light wire (R) and tail/brake lights wire to frame clamp.
- [J] Route the following cables through the frame bracket:  
rear turning signal wire (R), rear turning signal wire (L), tail/brake wire, license light wire.

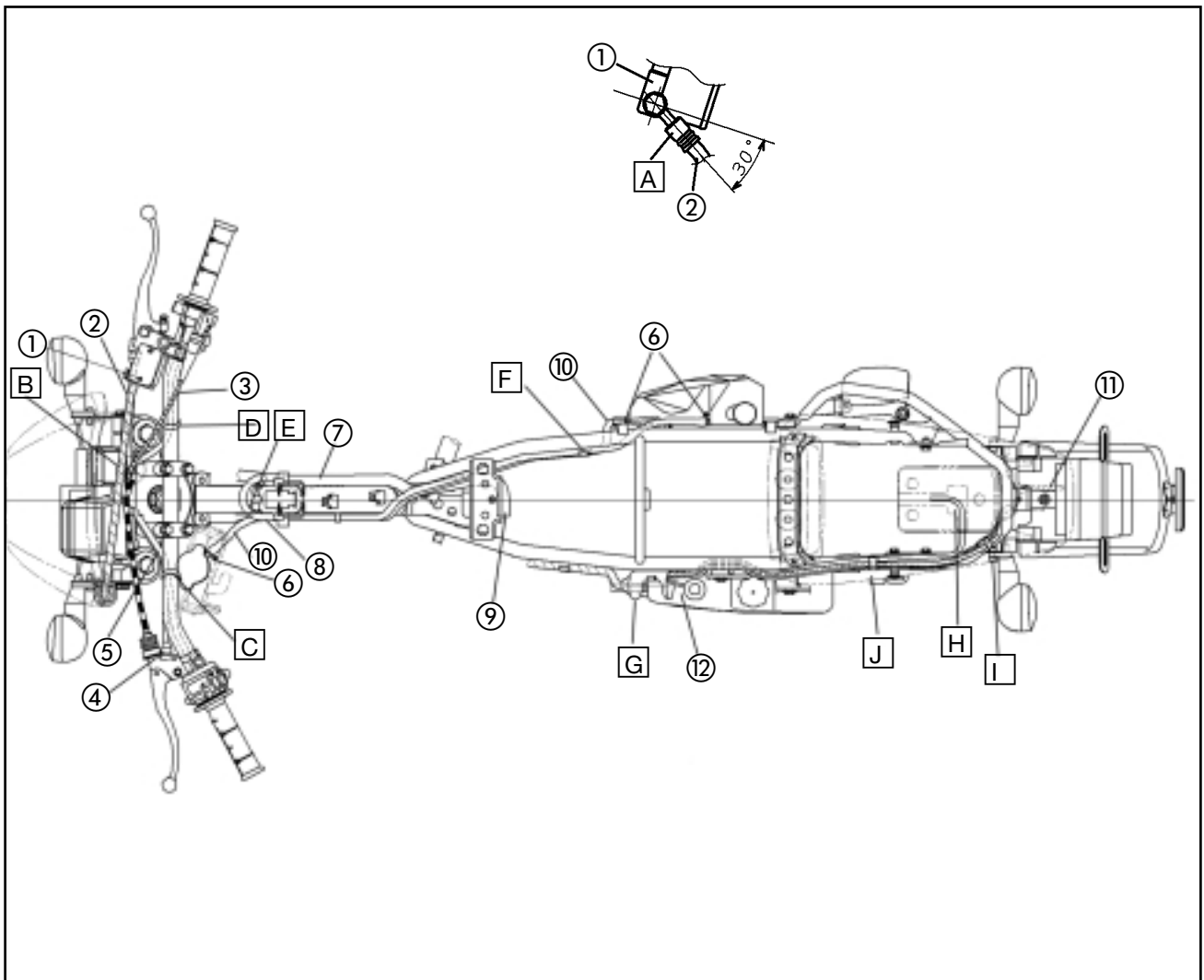





CABLE ROUTING

- ① Main switch wire lead
- ② Pipe overflow
- ③ Ignition coil
- ④ Horn
- ⑤ Flasher relay
- ⑥ Air vent hose
- ⑦ Fuel pipe
- ⑧ Oil pipe

- A Route speedometer cable to frame guide.
- B Route pipe overflow behind engine holder.
- C Screw ground wire and rectifier with the same bolt.
- D Pipe overflow pass behind oil hose.
- E Route carburetor breather hose between rear shock absorber and swingarm.
- F Route pipe overflow between rear shock absorber and swingarm.

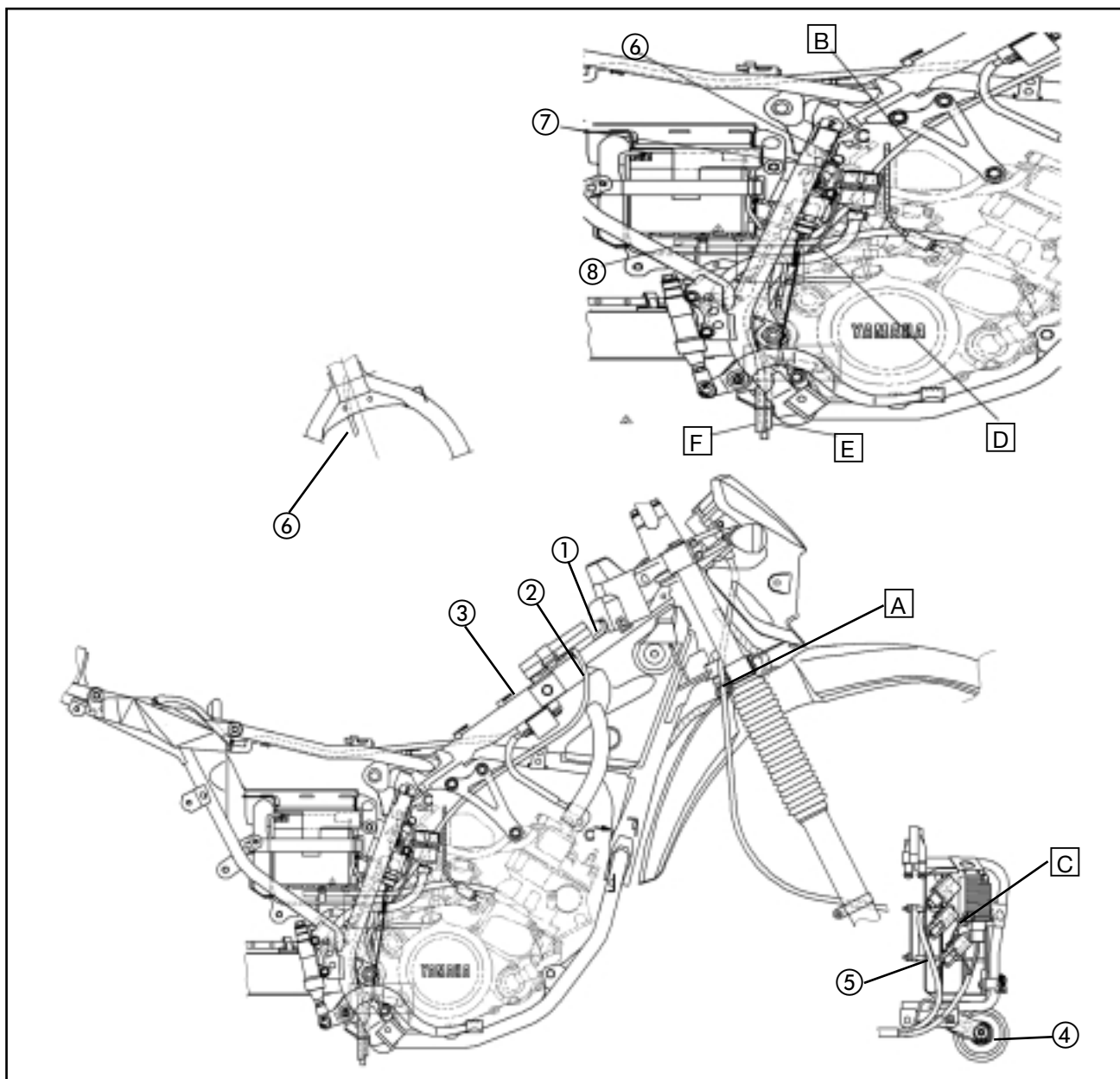



CABLE ROUTING

- ① Front brake hose
- ② Clutch wire
- ③ Ignition coil
- ④ Throttle wire
- ⑤ Therm switch
- ⑥ Sidestand switch wire lead
- ⑦ Oil hose

- [A] Route brake hose through the guide.
- [B] Clamp clutch wire.
- [C] Guide wire (chassis): SW handle wire lead (R), SW handle wire lead (L), clutch SW wire lead, front stop SW wire lead, wire throttle, wire clutch.
- [D] Insert installation clip to frame hole.
- [E] Route clutch wire through the guides.
- [F] Connect ground on the front part of the coil. Install screw and wire terminal.
- [G] Cover thermo-switch with cap.
- [H] Insert connector to frame clamp (X3).
- [I] Install clamp with open part to the upper side. Route pipe overflow and pipe I through clamp.
- [J] Route sidestand switch through brackets. The lead must have no slack at distance "X".
- [K] Route oil hose through clamp under the battery.
- [L] Route sidestand switch through the lower part of the air filter.

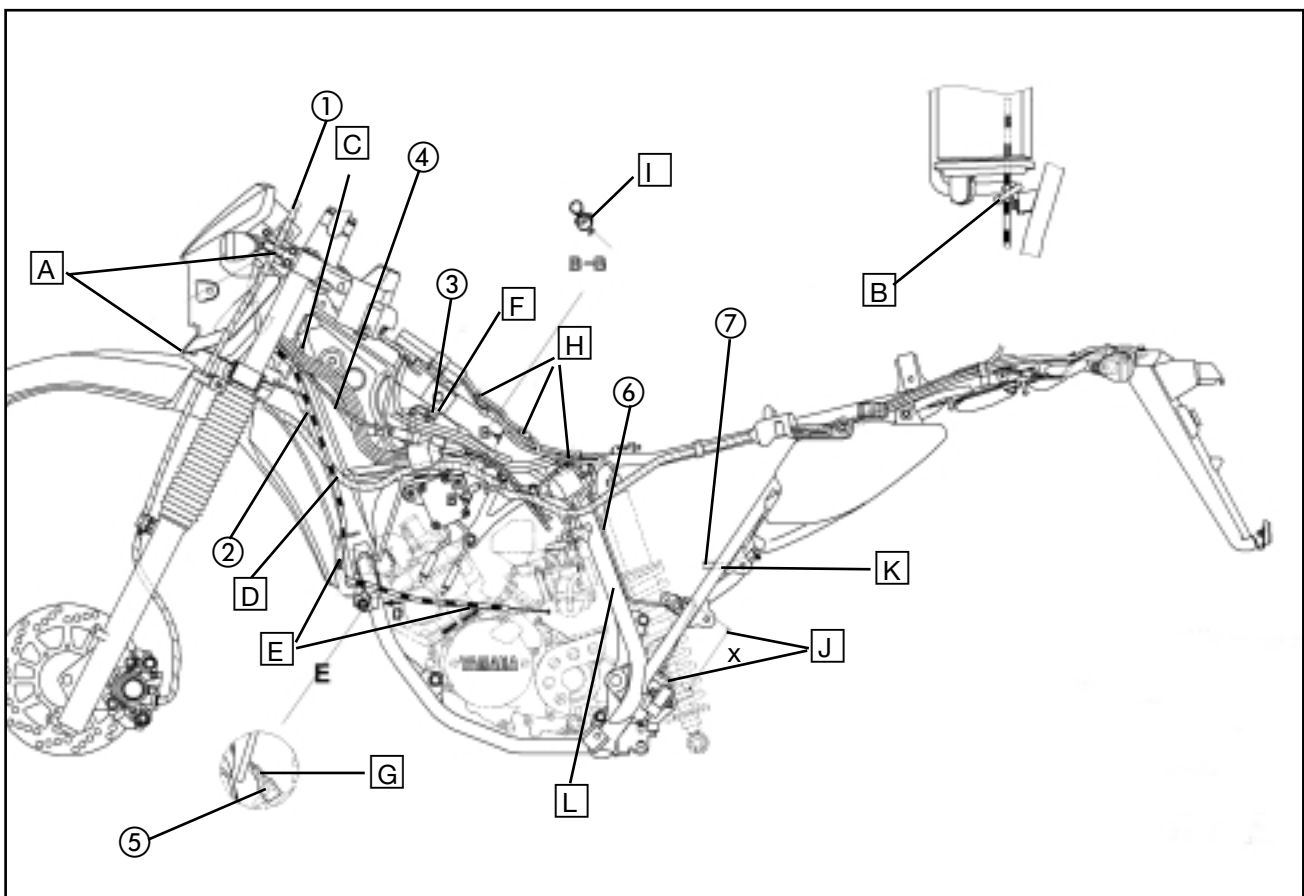



**CHK**



**ADJ**

**R**

**3**

## CHAPTER 3 PERIODIC CHECKS AND ADJUSTMENTS

<b>INTRODUCTION/PERIODIC MAINTENANCE/LUBRICATION</b> .....	3-1
<b>ENGINE</b> .....	3-2
Y.P.V.S. CABLE ADJUSTMENT .....	3-2
IDLE SPEED ADJUSTMENT .....	3-3
THROTTLE CABLE FREE PLAY ADJUSTMENT.....	3-4
CARBURETOR CABLE FREE PLAY ADJUSTMENT .....	3-5
AUTOLUBE PUMP STROKE ADJUSTMENT .....	3-6
AUTOLUBE PUMP AIR BLEEDING .....	3-6
SPARK PLUG INSPECTION .....	3-7
IGNITION TIMING CHECK .....	3-8
ENGINE OIL LEVEL INSPECTION .....	3-9
TRANSMISSION OIL LEVEL INSPECTION .....	3-11
TRANSMISSION OIL REPLACEMENT .....	3-11
CLUTCH ADJUSTMENT .....	3-12
AIR FILTER CLEANING.....	3-16
CARBURETOR JOINT INSPECTION .....	3-18
FUEL LINE INSPECTION .....	3-18
CHECKING THE CRANKCASE BREATHER HOSE.....	3-18
EXHAUST SYSTEM INSPECTION .....	3-19
ENGINE OIL LINE INSPECTION .....	3-19
COOLANT LEVEL INSPECTION .....	3-19
COOLANT REPLACEMENT .....	3-20
COOLING SYSTEM INSPECTION .....	3-23
<b>CHASSIS</b> .....	3-24
FRONT BRAKE ADJUSTMENT .....	3-24
REAR BRAKE ADJUSTMENT .....	3-24
BRAKE FLUID INSPECTION .....	3-25
BRAKE PAD INSPECTION .....	3-27
BRAKE LIGHT SWITCH ADJUSTMENT .....	3-27
BRAKE HOSE INSPECTION .....	3-28
DRIVE CHAIN SLACK ADJUSTMENT .....	3-28
DRIVE CHAIN LUBRICATION .....	3-30
STEERING HEAD ADJUSTMENT .....	3-30
FRONT FORK INSPECTION .....	3-32
REAR SHOCK ABSORBER ADJUSTMENT .....	3-33
TIRE INSPECTION.....	3-34
WHEEL INSPECTION .....	3-36
CABLE INSPECTION AND LUBRICATION .....	3-37
<b>ELECTRICAL</b> .....	3-39
BATTERY INSPECTION .....	3-39
FUSE INSPECTION .....	3-42
HEADLIGHT BULB REPLACEMENT .....	3-43
HEADLIGHT BEAM ADJUSTMENT .....	3-44

# INTRODUCTION/PERIODIC MAINTENANCE/ LUBRICATION INTERVALS

**CHK  
ADJ**



## PERIODIC CHECKS AND ADJUSTMENTS

**NOTE:**

- The annual checks must be performed every year, except if a kilometer-based maintenance is performed instead.
- From 30000 km, repeat the maintenance intervals starting from 6000 km.
- Items marked with an asterisk should be performed by a Yamaha dealer as they require special tools, data and technical skills.

No	ITEM	CHECK OR MAINTENANCE JOB	ODOMETER READING ( x 1.000 km)					ANUAL CHECK
			1	6	12	18	24	
1	* Fuel line	Check fuel hoses and vacuum hose for cracks or damage.		√	√	√	√	√
2	Spark plug	<ul style="list-style-type: none"> <li>• Check condition.</li> <li>• Clean and regap.</li> <li>• Replace.</li> </ul>		√		√		
3	Air filter element	<ul style="list-style-type: none"> <li>• Clean.</li> <li>• Replace.</li> </ul>		√		√		
4	Clutch	<ul style="list-style-type: none"> <li>• Check operation.</li> <li>• Adjust.</li> </ul>	√	√	√	√	√	
5	* Front brake	<ul style="list-style-type: none"> <li>• Check operation and adjust brake lever free play.</li> <li>• Replace brake shoes.</li> </ul>	√	√	√	√	√	√
6	* Rear brake	<ul style="list-style-type: none"> <li>• Check operation, fluid level and vehicle for fluid leakage.</li> <li>• Replace brake pads.</li> </ul>	√	√	√	√	√	√
7	* Brake hoses	<ul style="list-style-type: none"> <li>• Check for cracks or damage.</li> <li>• Replace.</li> </ul>		√	√	√	√	√
8	* Wheels	<ul style="list-style-type: none"> <li>• Check runout, spoke tightness and for damage.</li> <li>• Tighten spokes if necessary.</li> </ul>		√	√	√	√	
9	* Tires	<ul style="list-style-type: none"> <li>• Check tread depth and for damage.</li> <li>• Replace if necessary.</li> <li>• Check air pressure.</li> <li>• Correct if necessary.</li> </ul>		√	√	√	√	√
10	* Wheel bearings	• Check bearing for looseness or damage.		√	√	√	√	
11	* Swingarm	<ul style="list-style-type: none"> <li>• Check operation and for excessive play.</li> <li>• Lubricate with lithium-soap-based grease.</li> </ul>		√	√	√	√	
12	Drive chain	<ul style="list-style-type: none"> <li>• Check chain slack.</li> <li>• Make sure that the rear wheel is properly aligned.</li> <li>• Clean and lubricate.</li> </ul>						Every 500 km and after washing the motorcycle or riding in the rain
13	* Steering bearings	<ul style="list-style-type: none"> <li>• Check bearing play and steering for roughness.</li> <li>• Lubricate with lithium-soap-based grease.</li> </ul>	√	√	√	√	√	√
14	* Chassis fasteners	• Make sure that all nuts, bolts and screws are properly tightened.		√	√	√	√	√
15	Sidestand	<ul style="list-style-type: none"> <li>• Check operation.</li> <li>• Lubricate.</li> </ul>		√	√	√	√	√
16	* Sidestand switch	• Check operation.	√	√	√	√	√	√
17	* Front fork	• Check operation and for oil leakage.		√	√	√	√	
18	* Shock absorber assembly	• Check operation and shock absorber for oil leakage.		√	√	√	√	
19	* Rear suspension relay arm and connecting arm pivoting points	<ul style="list-style-type: none"> <li>• Check operation.</li> <li>• Lubricate with lithium-soap-based grease.</li> </ul>		√	√	√	√	
20	* Carburetor	<ul style="list-style-type: none"> <li>• Check starter (choke) operation.</li> <li>• Adjust engine idling speed.</li> </ul>	√	√	√	√	√	√
21	Engine oil	<ul style="list-style-type: none"> <li>• Change.</li> <li>• Check oil level and vehicle for oil leakage.</li> </ul>	√					When the oil change indicator light comes on (every 3,000 km) Every 3,000 km
22	* Autolube pump	<ul style="list-style-type: none"> <li>• Check operation.</li> <li>• Bleed if necessary.</li> </ul>	√		√		√	√
23	Transmission oil	<ul style="list-style-type: none"> <li>• Check oil level.</li> <li>• Change.</li> </ul>	√	√	√	√	√	√
24	* Cooling system	<ul style="list-style-type: none"> <li>• Check coolant level and vehicle for coolant leakage.</li> <li>• Change.</li> </ul>		√	√	√	√	√
25	* Throttle grip housing and cable	<ul style="list-style-type: none"> <li>• Check operation and free play.</li> <li>• Adjust the throttle cable free play if necessary.</li> <li>• Lubricate the throttle grip housing and cable.</li> </ul>		√	√	√	√	√

# Y.P.V.S. CABLE ADJUSTMENT

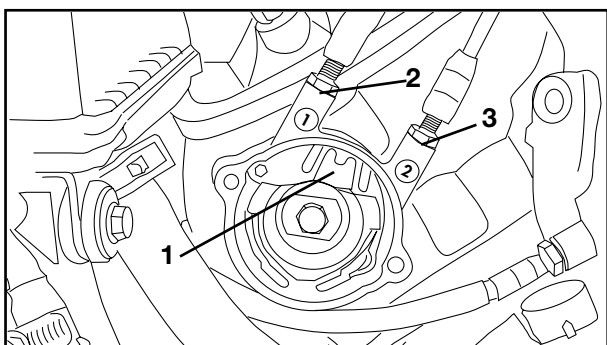
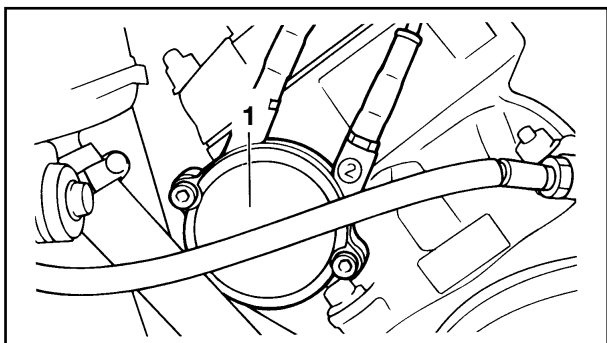

## ENGINE

### Y.P.V.S. CABLE ADJUSTMENT

1. Remove
  - pulley cover (power valve) ①
2. Turn on the main switch

### NOTE

If the Y.P.V.S. Doesn't operate, refer to the "Y.P.V.S. SYSTEM" in CHAPTER 9

3. Check
  - alignment mark ①
  - Not aligned → Adjust the Y.P.V.S. Cables

4. Adjust
  - Y.P.V.S. Cables



### Adjustments steps:

- Loosen both locknuts ② and turn in both adjusters ③ .
- Insert a pin [fl 0,16 in.]) through the aligning indent in the pulley and into the hole to lock the pulley.
- Turn both adjusters, counterclockwise so that the cable free play becomes zero mm (zero in.) with fingers.
- Turn both adjusters 1/4 turn clockwise.
- Tighten the locknuts.

	<b>Locknuts:</b> <b>8 Nm (0,8 m•kg, 5,8 ft•lb)</b>
---	---

- Turn on the main switch and check taht the alignment mark is aligned.
- If not, rpeat the above steps.

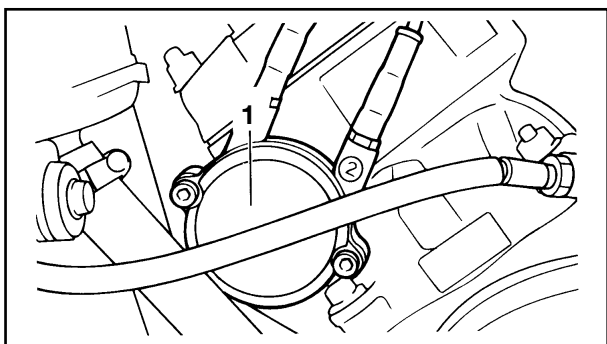

5. Install
  - pulley cover (Power valve) ①

	<b>Locknuts:</b> <b>7 Nm (0,7 m•kg, 5,1 ft•lb)</b>
---	---

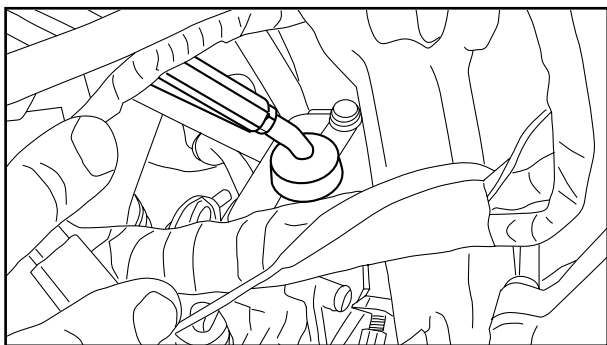
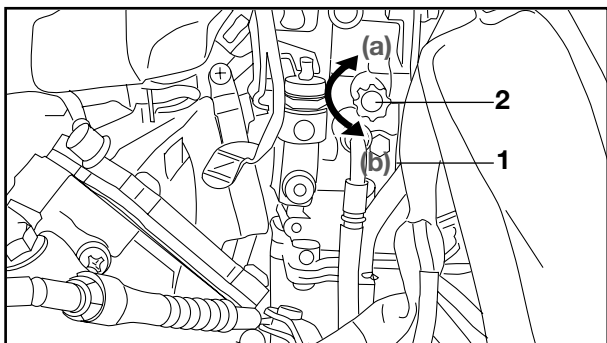

### IDLE SPEED ADJUSTMENT

1. Adjust:
  - engine idle speed

EAS00054

### ADJUSTING THE ENGINE IDLING SPEED

**NOTE:** \_\_\_\_\_

Prior to adjusting the engine idling speed, the air filter element should be clean, and the engine should have adequate compression.

1. Start the engine and let it warm up for several minutes.
2. Connect:
  - engine tachometer (onto the spark plug lead of cylinder #1)



**Engine tachometer**  
90890-03113

3. Check:
  - engine idling speed
 Out of specification → Adjust.



**Engine idling speed**  
1250 ~ 1450 r/min

4. Adjust:
  - engine idling speed



- a. Turn the pilot screw ① in or out until it is lightly seated.
- b. Turn the pilot screw out the specified number of turns.



**Pilot screw setting**  
1/4 turns out

- c. Turn the throttle stop screw ② in direction ③ or ④ until the specified engine idling speed is obtained.

<b>Direction ③</b>	<b>Engine idling speed is increased.</b>
<b>Direction ④</b>	<b>Engine idling speed is decreased.</b>

<b>Engine idling speed is increased.</b>
<b>Engine idling speed is decreased.</b>



5. Adjust:
  - throttle cable free play  
Refer to "ADJUSTING THE THROTTLE CABLE FREE PLAY".



**Throttle cable free play (at the flange of the throttle grip)**  
3 ~ 5 mm (0,11 ~ 0,18 in)



# ADJUSTING THE THROTTLE CABLE FREE PLAY

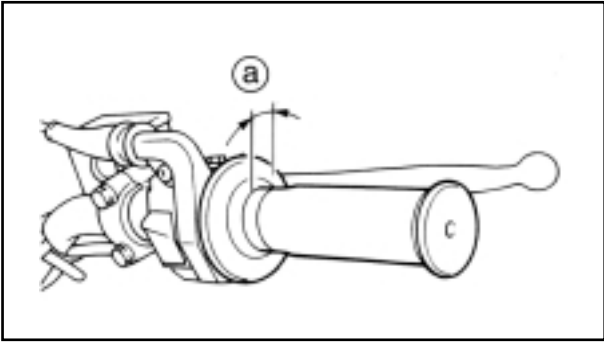

EAS00058

## ADJUSTING THE THROTTLE CABLE FREE PLAY

**NOTE:** \_\_\_\_\_

Prior to adjusting the throttle cable free play, the engine idling speed and carburetor synchronization should be adjusted properly.

1. Check:
  - throttle cable free play (a)
 Out of specification → Adjust.

	<b>Throttle cable free play (at the flange of the throttle grip)</b> 3 ~ 5 mm (0,11 ~ 0,19 in)
--	---

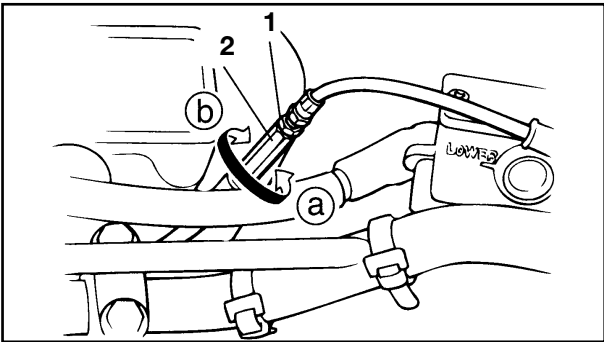

2. Adjust:
  - throttle cable free play



### Handlebar side

- a. Loosen the locknut (1).
- b. Turn the adjusting nut (2) in direction (a) or (b) until the specified throttle cable free play is obtained.

Direction (a)	Throttle cable free play is increased.
Direction (b)	Throttle cable free play is decreased.

- c. Tighten the locknut.

**⚠ WARNING** \_\_\_\_\_

After adjusting the throttle cable free play, start the engine and turn the handlebar to the right or left to ensure that this does not cause the engine idling speed to change.



# ADJUSTING THE THROTTLE CABLE FREE PLAY/ CARBURETOR CABLE FREE PLAY ADJUSTMEN



## CARBURETOR CABLE FREE PLAY ADJUSTMENT

**NOTE:** \_\_\_\_\_

Before adjusting carburetor cable, throttle cable free play should be adjusted.

---

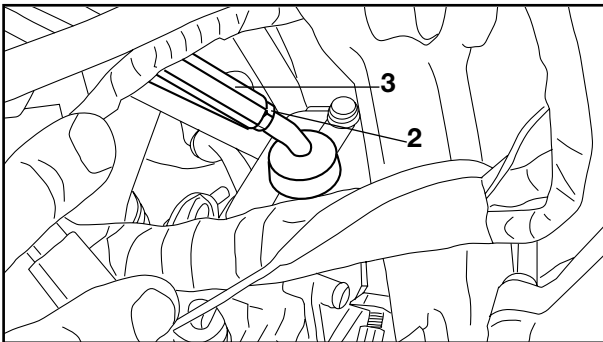

1. Pull back the adjuster cover.

2. Check:

- carburetor cable free play @  
Out of specification → adjust

	<b>Carburetor Cable Free Play:</b> <b>1,0 mm (0,04 in)</b>
--	---

3. Adjust:

- Carburetor free play



### Adjustment steps:

- Loosen the locknut (2)
- Turn the adjuster (3) in or out until the correct free play obtained.

<b>Turn in</b>	<b>Free play is increased.</b>
<b>Turn out</b>	

- Tighten the locknuts



4. Push in the adjuster cover.



# AUTOLUBE PUMP AIR BLEEDING/ CHECKING THE SPARK PLUG

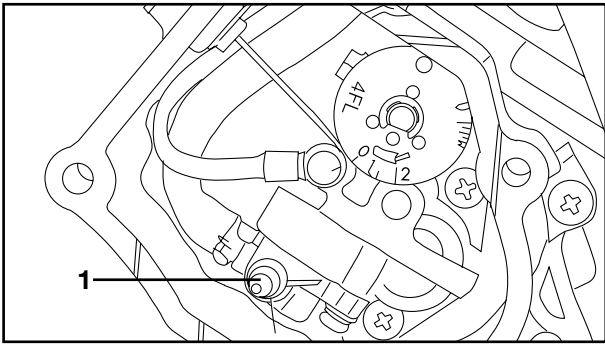

3. Air bled:
  - pump case and/or oil pipe



### Air bleeding steps

- Remove the bleed cap ①
- Start the engine.
- Keep the oil running out until air bubbles disappear.
- Keep the engine running at about 2.000r/min for two minutes or so
- When air bubbles are expelled completely, install the bleed cap.

### NOTE: \_\_\_\_\_

Place a rag or oil pan under the autolube pump to catch the oil.



EAS00060

## CHECKING THE SPARK PLUG

1. Disconnect:
  - spark plug cap
2. Remove:
  - spark plug

### CAUTION \_\_\_\_\_

**Before removing the spark plug, blow away any dirt accumulated in the spark plug well with compressed air to prevent it from falling into the cylinder.**

3. Check:
  - spark plug type  
Incorrect → Change.

	<b>Spark plug type (manufacturer) BR8ES (NGK)</b>
--	---

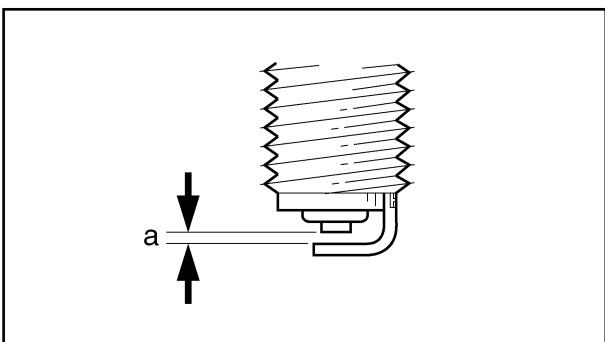

4. Check:
  - electrode ①  
Damage/wear → Replace the spark plug.
  - insulator ②  
Abnormal color → Replace the spark plug.  
Normal color is medium-to-light tan.
5. Clean:
  - spark plug  
(with a spark plug cleaner or wire brush)

## CHECKING THE SPARK PLUG/ CHECKING THE IGNITION TIMING

CHK  
ADJ



6. Measure:
- spark plug gap @  
(with a wire Thickness gauge)  
Out of specification → Regap.



**Spark plug gap**  
0,7-0,8mm (0,0276-0,03315in)

7. Install:
- spark plug



**Spark plug**  
20Nm (2,0m·kg, 14ft·lb)

### NOTE:

Before installing the spark plug, clean the spark plug and gasket surface.

8. Connect:
- spark plug cap

EAS00064

## CHECKING THE IGNITION TIMING

### NOTE:

Prior to checking the ignition timing, check the wiring connections of the entire ignition system. Make sure all connections are tight and free of corrosion.

1. Remove:
- crankcase cover (left)
2. Connect:
- timing light
  - engine tachometer  
(onto the spark plug lead of cylinder #1)



**Timing light**  
90890-03141  
**Engine Tachometer**  
90890-03113

## CHECKING THE IGNITION TIMING/ ENGINE OIL LEVEL INSPECTION

CHK  
ADJ



### 3. Check:

- ignition timing



- a. Start the engine, warm it up for several minutes, and then let it run at the specified engine idling speed.



**Engine idling speed**  
**1250-1450 r/min**

- b. Check that the stationary pointer is within the firing range on the generator rotor.  
Incorrect firing range → Check the ignition system.

**NOTE:** \_\_\_\_\_

The ignition timing is not adjustable.



### 4. Install:

- Crankcase cover (left)

## ENGINE OIL LEVEL INSPECTION

### 1. Check

- oil level  
oil level low → Adjust sufficient oil



**Recommended oil:**  
**Yamaha Oil 2T or Air Cooled 2**  
**stroke Engine Oil**

**Oil Tank Capacity:**  
**1,3 L**



## OIL WARNING LIGHT CHECKING METHOD

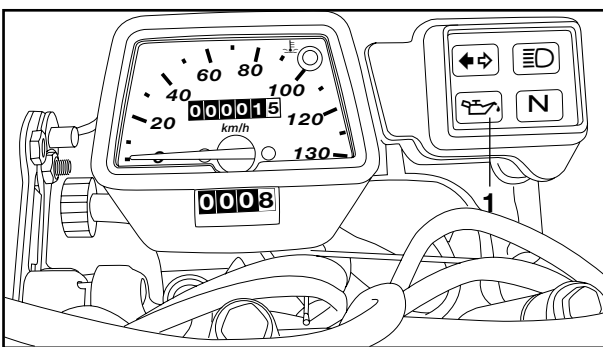
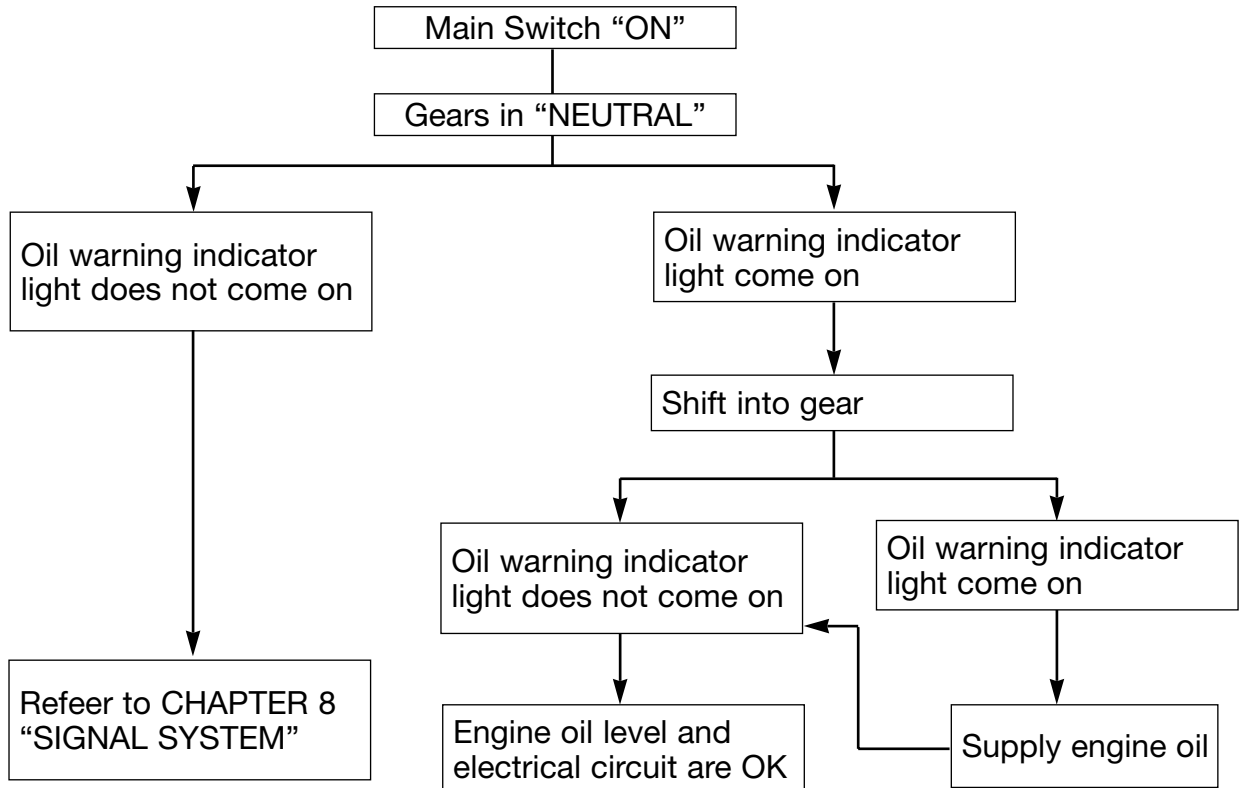

### CAUTION

Always use the same type of engine oil; mixing oils may result in a harmful chemical reaction and lead to poor performance.

- ① "OIL" Indicator light

# TRANSMISSION OIL LEVEL INSPECTION/ TRANSMISSION OIL REPLACEMENT



## TRANSMISSION OIL LEVEL INSPECTION

- Inspect:
  - transmission oil level  
Oil level low → Add sufficient oil



### Transmission oil level steps:

- Place the machine on a level surface.
- Warm up the engine for several minutes and stop it.
- Visually check the oil level through the level window ①.

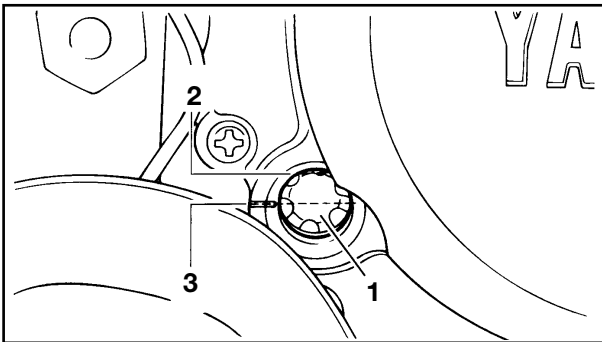

### NOTE:

- Check the oil level just one minute after stopping the engine.
- The oil should be confirmed between maximum ② and minimum ③ marks.
- If the oil level is lower, add sufficient oil to raise it to the proper level.

	<b>Recommended oil:</b> <b>SAE10W30 Type SE Motor Oil</b>
--	--

- Do not add any chemical additives. Transmission oil also lubricates the clutch and additives could cause clutch slippage.
- Be sure no foreign material enters the crankcase.

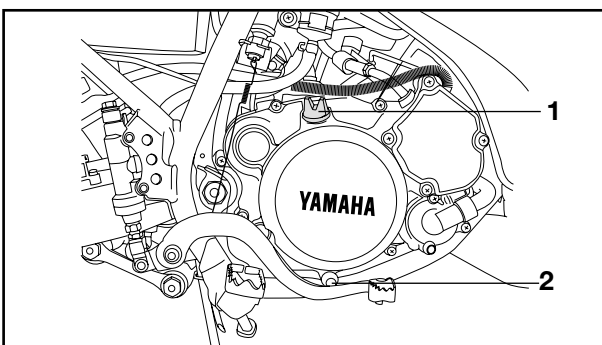

## TRANSMISSION OIL REPLACEMENT

- Warm up the engine for several minutes.
- Place a container under the engine.
- Remove:
  - oil filler cap ①
  - drain plug ②  
drain transmission oil.

### NOTE:

Drain the transmission oil with the motorcycle slightly inclined to the right.

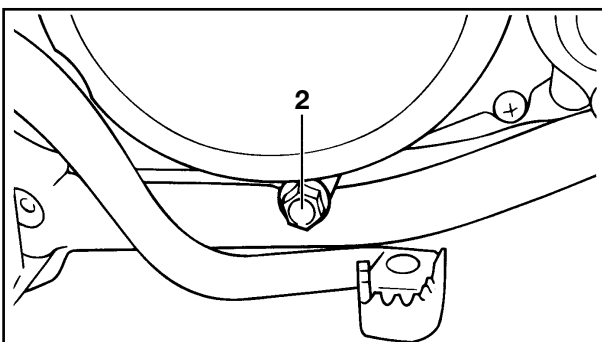

- Inspect:
  - gasket (Drain plug)
  - O-Ring (oil filter cap)  
Damage → Replace



# TRANSMISSION OIL REPLACEMENT/ ADJUSTING THE CLUTCH CABLE FREE PLAY



5. Install:
- Drain plug

 **Spark plug**  
15Nm (1,5m·kg, 11ft·lb)

6. Fill:
- Crankcase

 **Recomended oil:**  
**SAE 10W30 Type SE Motor Oil**  
**Periodic oil change:**  
**0,75L**

### CAUTION

- Do not add any chemical additives. Transmission oil also lubricates the clutch and additives could cause clutch slippage.
- Be sure no foreign materials enters the crankcase.

7. Install:
- Oil filler cap
8. Inspect:
- Oil leaks
  - Oil level

### NOTE:

Wipe off any oil spilled on the crankcase.

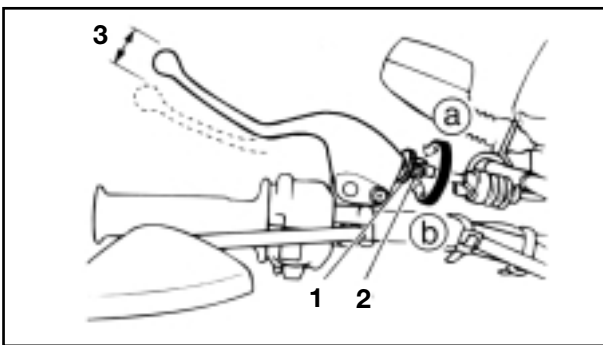

EAS00078

## ADJUSTING THE CLUTCH CABLE FREE PLAY

1. Check:
- clutch cable free play (3)  
Out of specification → Adjust.

 **Clutch cable free play (at the end of the clutch lever)**  
**10-15mm (0,34-0,59in.)**

2. Adjust:
- clutch cable free play (3)

### Handlebar side

- a. Loosen the locknut (1).
- b. Turn the adjusting bolt (2) in direction (a) or (b) until the specified clutch cable free play is obtained.

# ADJUSTING THE CLUTCH CABLE FREE PLAY



Direction Ⓐ	Clutch cable free play is increased.
Direction Ⓑ	Clutch cable free play is decreased.

c. Tighten the locknut.

**NOTE:** \_\_\_\_\_

If the specified clutch cable free play cannot be obtained on the handlebar side of the cable, use the adjusting nut on the engine side.

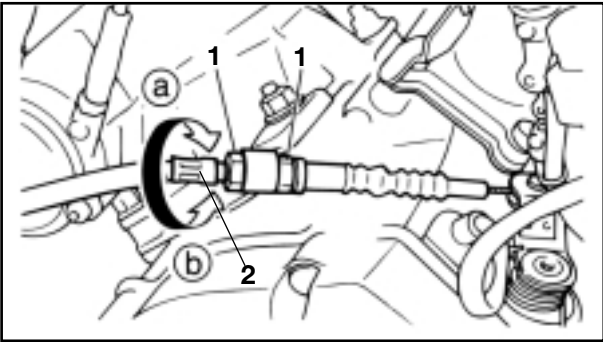

**Engine side**

- a. Loosen the locknuts ①.
- b. Turn the adjusting bolt ② in direction Ⓐ or Ⓑ until the specified clutch cable free play is obtained.

Direction Ⓐ	Clutch cable free play is increased.
Direction Ⓑ	Clutch cable free play is decreased.

c. Tighten the locknuts.

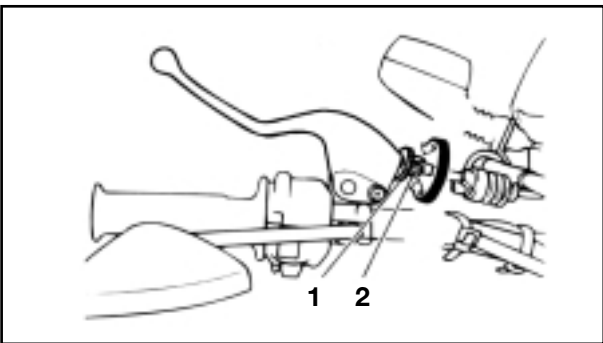

**Mechanism adjustment**

1. Remove:
  - Brush guard
2. Loosen:
  - Locknuts ①
3. Turn the adjusters ②.

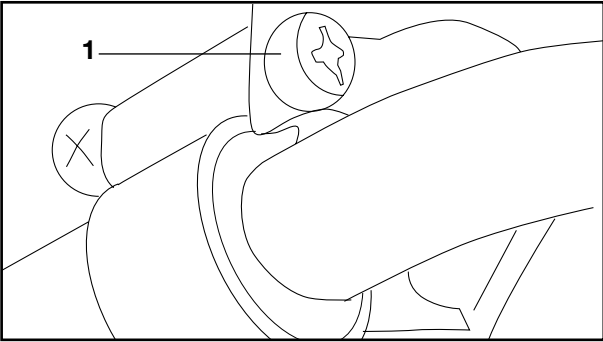

4. Drain:
  - Coolant  
Refer to the "COOLANT REPLACEMENT" section.
5. Disconnect:
  - Outlet hose (radiator)
6. Remove:
  - Screw (Water outlet pipe) ①

# ADJUSTING THE CLUTCH CABLE FREE PLAY

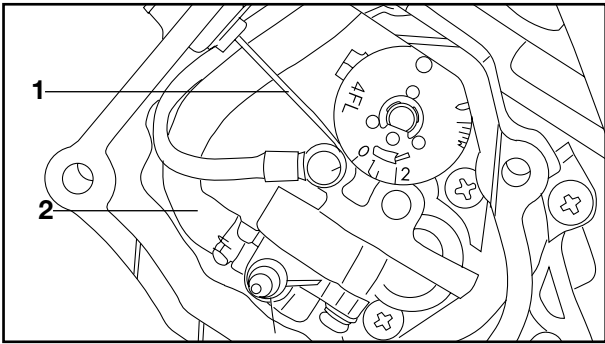

7. Disconnect:
- Autolube pump cable ①
  - Autolube pump hose ②
- Refer to the "AUTOLUBE PUMP CABLE AND HOSE" section in the CHAPTER 4.

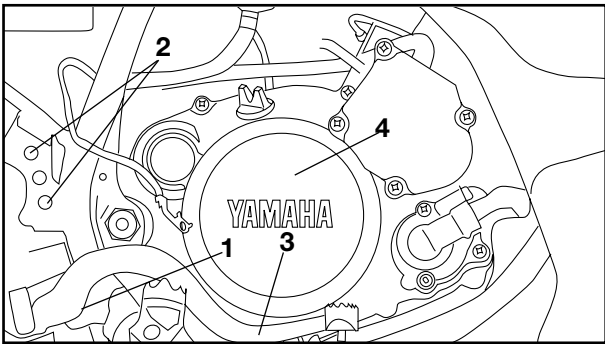

8. Drain:
- Transmission oil
- Refer to the "TRANSMISSION OIL REPLACEMENT" section.
9. Remove:
- Return spring ①
  - Bolt (master cylinder) ②
  - Brake pedal ③
  - Crankcase cover (Right) ④

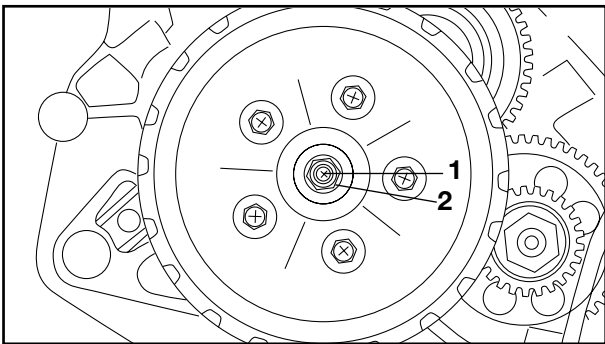



10. Adjust:
- Adjuster (push rod=1) ①

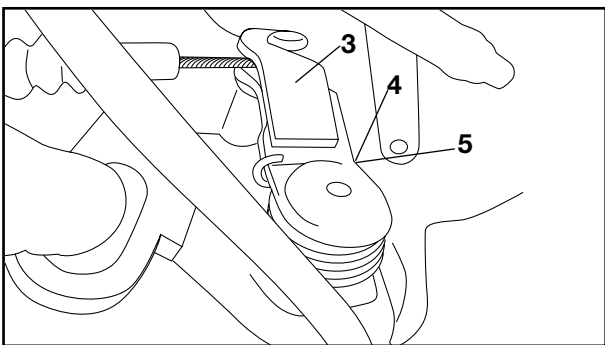

### Adjustments steps:

- Loosen the locknut ②
- Move the push lever ③ toward the front with you finger until it stops.
- With the push lever in this position turn the adjuster ① to align the mark ④ on the end of the push lever with the mark ⑤ (protuberance) on the crankcase.
- Tighten the locknut ②.



	<b>Locknut</b> 8 Nm (0,8 m • kg, 5,8 ft • lb)
---	--



11. Install:
- crankcase cover (right)
  - brake pedal
  - return spring

	<b>Screw (crankcase cover):</b> 8 Nm (0,8 m • kg, 5,8 ft • lb)
	<b>Drain plug (Oil):</b> 15 Nm (1,5 m • kg, 11 ft • lb)
	<b>Drain plug (coolant):</b> 10 Nm (1,0 m • kg, 7,2 ft • lb)
	<b>Screw (brake pedal):</b> 20 Nm (2,0 m • kg, 14 ft • lb)

## ADJUSTING THE CLUTCH CABLE FREE PLAY

CHK  
ADJ

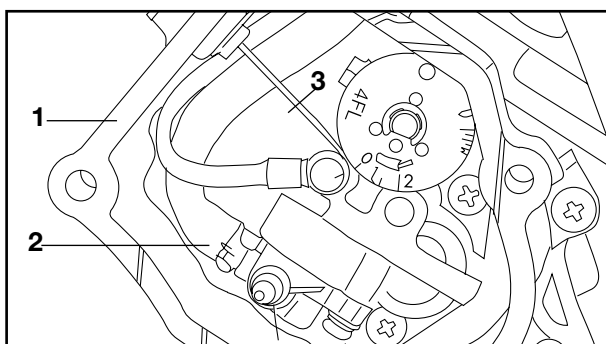

### NOTE:

- When installing the crankcase cover, engage the autolube pump drive gear with its driven gear as slowly turn the autolube pump shaft.
- Tighten the screws (Crankcase cover) in stage, using a crisscross pattern.
- Before installing the brake pedal apply the lithium soap base grease to the brake pedal pivot shaft.

12. Install:
  - Gasket (Autolube pump cover) ①
13. Connect:
  - Autolube pump hoses ②
  - Autolube pump cable ③
14. Install:
  - Screw (Water outlet pipe) ①



**Screw (Water outlet Pipe)**  
8 Nm (0,8 m • kg, 5,8 ft • lb)

15. Connect:
  - Outlet hose (Radiator)
16. Adjust:
  - Clutch cable free play  
Refer to the "Cable free play adjustment" section."

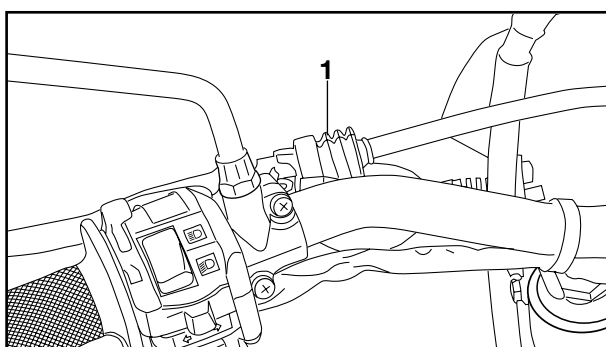

17. Install:
  - Brush guard ①
18. Fill:
  - Crankcase  
Refer to the "TRANSMISSION OIL REPLACEMENT" section.



**Recommended oil:**  
**SAE10W30 Type SE Motor Oil**  
**Periodic Oil Change**  
**0,75 L**

19. Fill:
  - Radiator
  - Reservoir tank (radiator)  
Refer to the "COOLANT REPLACEMENT" section.

**Total amount:**  
**0,92 L**

## ADJUSTING THE CLUTCH CABLE FREE PLAY/ CLEANING THE AIR FILTER ELEMENT

CHK  
ADJ

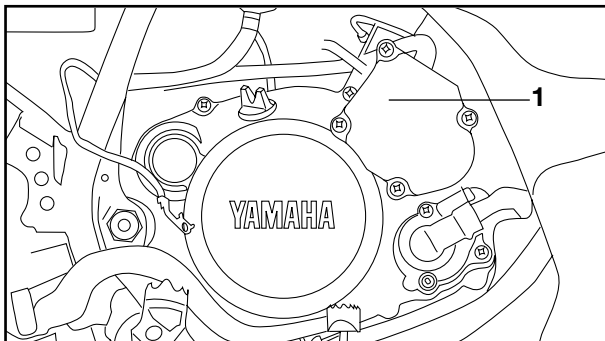

20. Air bleeding:
- Autolube pump  
Refer to the "AUTOLUBE PUMP AIR BLEEDING" section.

21. Install:
- Autolube pump cover ①



**Screw (autolube pump cover)**  
5 Nm (0,5 m • kg, 3,6 ft • lb)

EAS00089

### CLEANING THE AIR FILTER ELEMENT

#### NOTE:

On the bottom of the air filter case is a check hose ①. If dust or water or both collects in this hose, clean the air filter element and air filter case.

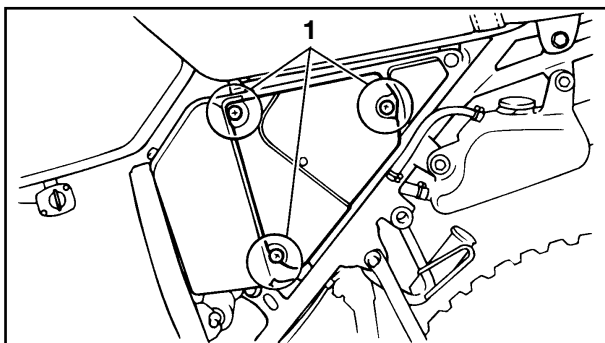
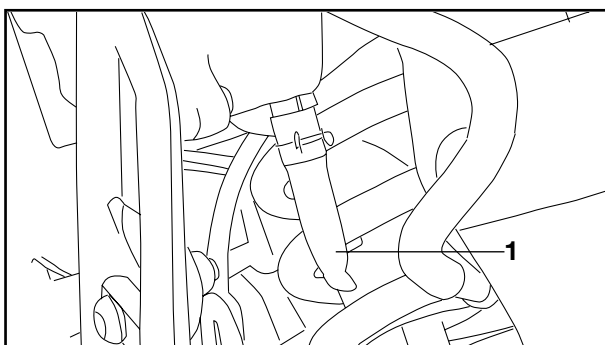

1. Remove:
- Side cover (left)

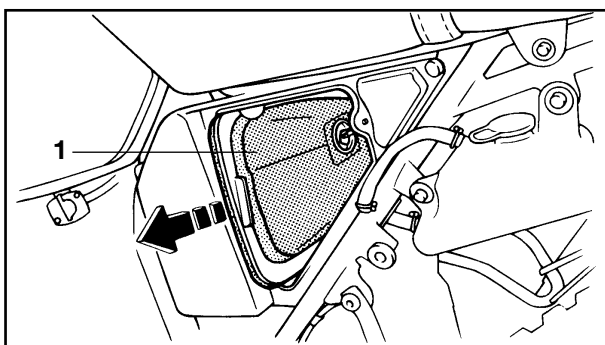

2. Remove:
- air filter case cover screws ①
  - air filter assembly ①  
Slide out guide together with element

3. Clean:
- air filter element  
(with solvent)

#### **⚠ WARNING**

**Never use low flash point solvents, such as gasoline, to clean the air filter element. Such solvents may cause a fire or an explosion.**

#### NOTE:

After cleaning, gently squeeze the air filter element to remove the excess solvent.

## CLEANING THE AIR FILTER ELEMENT

CHK  
ADJ

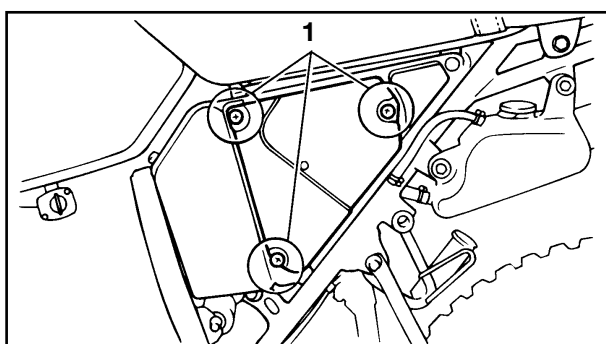
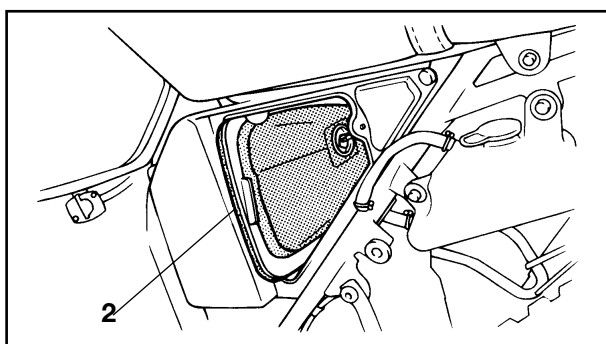
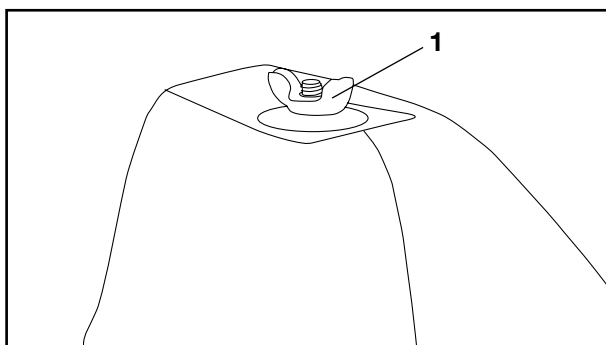
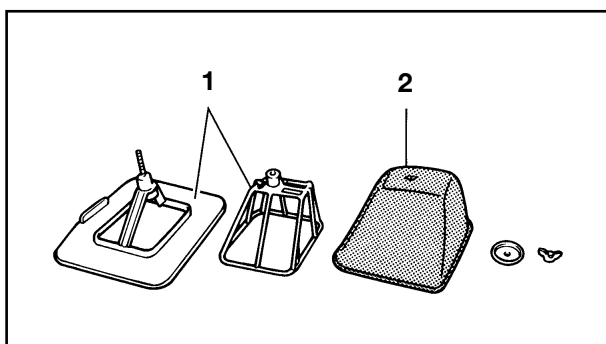

### CAUTION

Do not twist the air filter element when squeezing it.

4. Check:
- air filter element  
Damage → Replace.

5. Apply the recommended oil to the entire surface of the air filter element and squeeze out the excess oil. The air filter element should be wet but not dripping.



Recommended oil  
SAE10W30

6. Install:
- air filter element
  - air filter element (to element guide)

### NOTE:

Install the washer ① with its bent fringe upwards as shown.

- Air filter assembly.  
Slide in guide to air case.

### CAUTION

Be sure to insert the element guide into the filter case with its handle ② located close to you, and also pay attention to the seal sponge for damage.

7. Install:
- Side cover (left)

## CARBURETOR JOINT INSPECTIONS /FUEL LINE INSPECTION/CHECKING THE CRANKCASE BREATHER HOSE

CHK  
ADJ

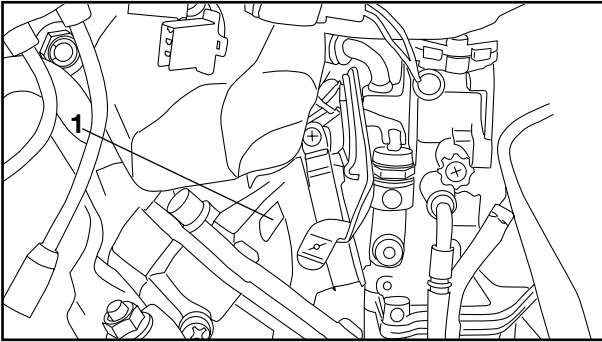

### CARBURETOR JOINT INSPECTION

1. Inspect:
  - Carburetor joint ①  
Crack-damage → Replace  
Refer to the "REED VALVE" section in chapter 7 for replacement
2. Check the tightening torque of the carburetor joint securing bolts.



**Bolt (Carburetor joint)**  
**8 Nm (0,8 m • kg, 5,8 ft • lb)**

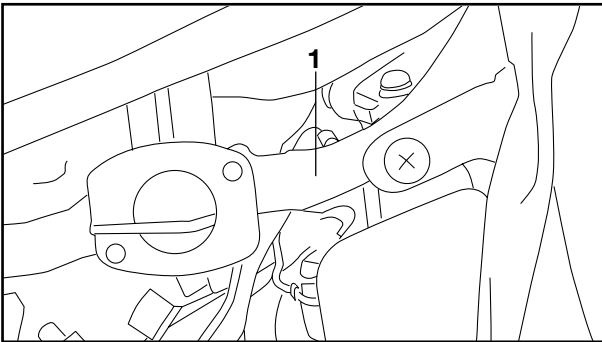

### FUEL LINE INSPECTION

1. Inspect:
  - Fuel hose ①  
Cracks-damage → replace  
Loose connection → Connect properly

EAS00098

### CHECKING THE CRANKCASE BREATHER HOSE

1. Check:
  - crankcase breather hose  
Cracks/damage → Replace.  
Loose connection → Connect properly.

#### CAUTION

**Make sure the crankcase breather hose is routed correctly.**



# EXHAUST SYSTEM INSPECTION/ENGINE OIL LINE INSPECTION/ COOLANT LEVEL INSPECTION

CHK  
ADJ

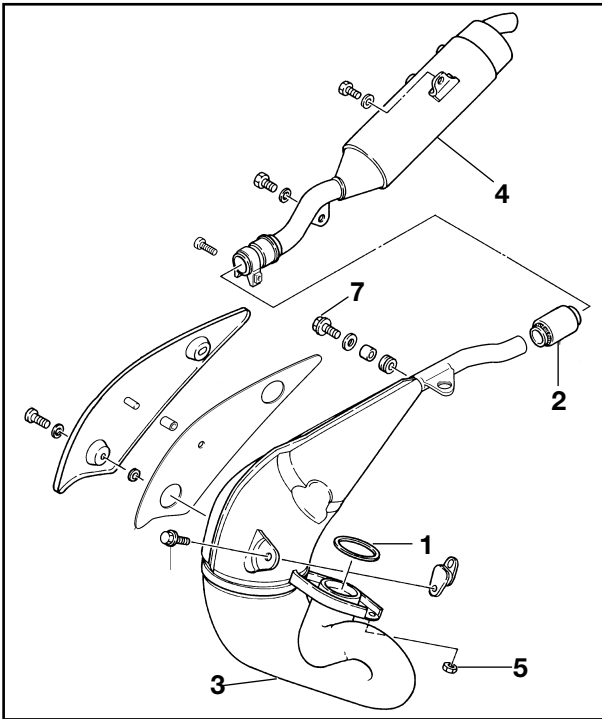

## EXHAUST SYSTEM INSPECTION

1. Inspect:
  - Gasket (exhaust pipe) ①
  - Joint (Silencer) ②  
Damage → Replace  
Exhaust gas leakage → Repair
  - Exhaust pipe ③
  - Silencer ④  
Cracked/Dent/Damage → Repair or replace
2. Tighten:
  - Exhaust pipe
  - Muffler

	<b>Nut ⑤ (Exhaust pipe)</b> 18 Nm (1,9 m • kg, 13 ft • lb)
	<b>Screw ⑥ (Muffler Joint)</b> 10 Nm (1,0 m • kg, 7,2 lb • ft)
	<b>Bolts ⑦</b> 10 Nm (1,0 m • kg, 7,2 lb • ft)

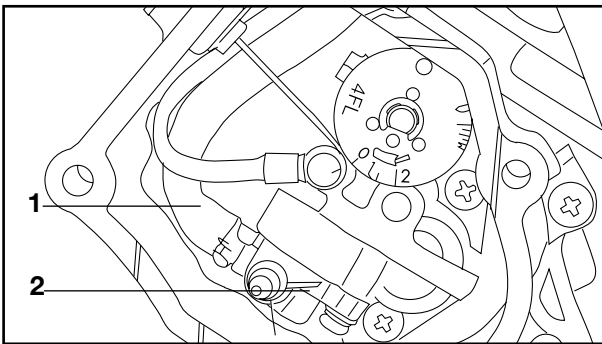

## ENGINE OIL LINE INSPECTION

1. Remove:
  - Autolube pump cover
2. Inspect:
  - Oil hose ①
  - Oil delivery hose ②  
Cracks-damage → replace  
Loose connection → Connect properly
3. Install:
  - Autolube pump cover

	<b>Screw (autolube pump cover)</b> 7 Nm (0,7 m • kg, 5,1 ft • lb)
---	--

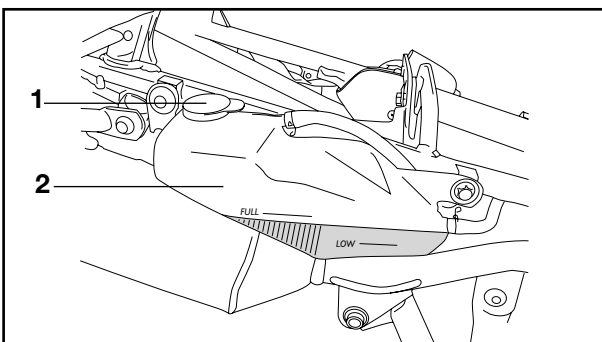

## COOLANT LEVEL INSPECTION

1. Place the machine in a level surface.
2. Remove:
  - Side cover (left)
3. Inspect:
  - Coolant level  
Coolant level is under “Low” level line  
① → Add soft water (tap water).  
② Coolant reservoir tank.



## COOLANT LEVEL INSPECTION/ CHANGING THE COOLANT

CHK  
ADJ



### **⚠ WARNING**

Do not remove the radiator cap when the engine is hot.

### **CAUTION**

Hard water or salt water is harmful to the engine parts; use boiled or distilled water if you can't get soft water.

4. Add:
  - Soft water (tap water)  
Until the coolant level reaches "FULL" level line.



#### Reservoir tank capacity

Total

0,30 L

From "LOW" to "FULL" Level

0,24 L

5. Install:
  - Side cover (Left).

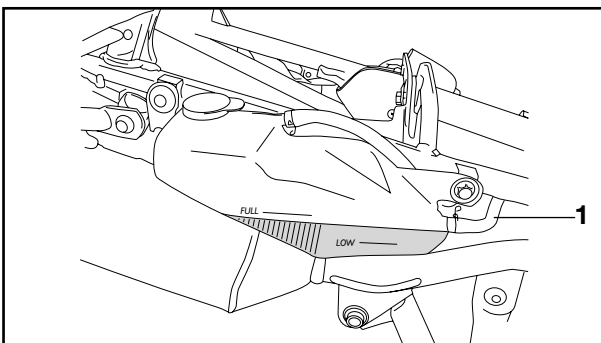

EAS00105

### CHANGING THE COOLANT

1. Remove:
  - side covers (left and right)
  - exhaust pipe.
2. Disconnect:
  - coolant reservoir hose ①
3. Drain:
  - coolant  
(from the coolant reservoir)
4. Remove:
  - radiator cap

### **⚠ WARNING**

A hot radiator is under pressure. Therefore, do not remove the radiator cap when the engine is hot. Scalding hot fluid and steam may be blown out, which could cause serious injury. When the engine has cooled, open the radiator cap as follows:  
Place a thick rag or a towel over the radia-

## CHANGING THE COOLANT

CHK  
ADJ

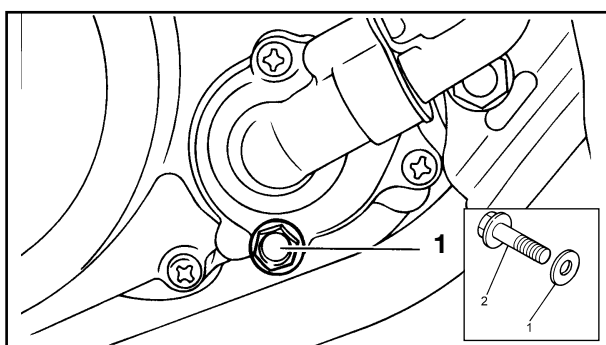
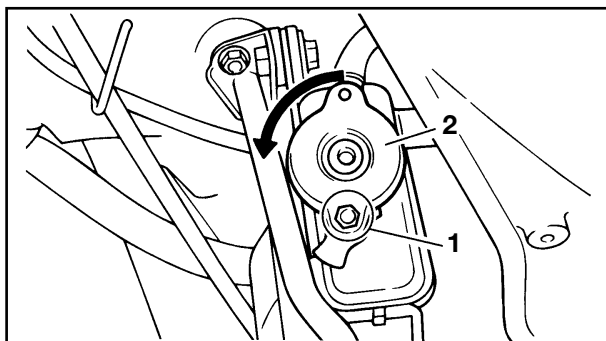

tor cap and slowly turn the radiator cap counterclockwise toward the detent to allow any residual pressure to escape. When the hissing sound has stopped, press down on the radiator cap and turn it counterclockwise to remove.

The following procedure applies to all of the coolant drain bolts and copper washers.

5. Remove:
  - coolant drain bolt (engine) ① (along with the copper washer)
6. Drain:
  - coolant (from the engine and radiator)
7. Check:
  - copper washer ① (coolant drain bolt-engine ②)
8. Install:
  - coolant drain bolt (engine)



**Coolant drain bolt (engine):**  
**10Nm (1.0 m·kg, 7,2lb·ft)**

9. Connect:
  - coolant reservoir hose
10. Fill:
  - cooling system (with the specified amount of the recommended coolant)



**Recommended antifreeze**  
**High-quality ethylene glycol anti-freeze containing corrosion inhibitors for aluminum engines**  
**Mixing ratio**  
**1:1 (antifreeze:water)**  
**Quantity**  
**Total amount**  
**0,92 L (0,81 Imp qt, 0,97 US qt)**  
**Coolant reservoir capacity**  
**0,30 L (0,26 Imp qt, 0,32 US qt)**  
**From minimum to maximum level mark**  
**0,24 L (0,21 Imp qt, 0,25 US qt)**

### Handling notes for coolant

Coolant is potentially harmful and should be handled with special care.

### WARNING

- If coolant splashes in your eyes, thoroughly wash them with water and consult a doctor.
- If coolant splashes on your clothes, quickly wash it away with water and then

## CHANGING THE COOLANT

CHK  
ADJ



with soap and water.

- If coolant is swallowed, induce vomiting and get immediate medical attention.

### CAUTION

- Adding water instead of coolant lowers the antifreeze content of the coolant. If water is used instead of coolant check, and if necessary, correct the antifreeze concentration of the coolant.
- Use only distilled water. However, if distilled water is not available, soft water may be used.
- If coolant comes into contact with painted surfaces, immediately wash them with water.
- Do not mix different types of antifreeze.

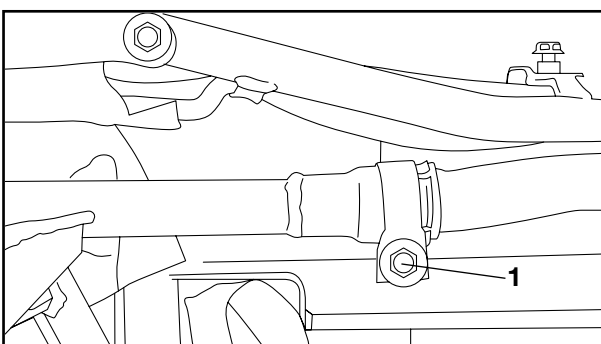
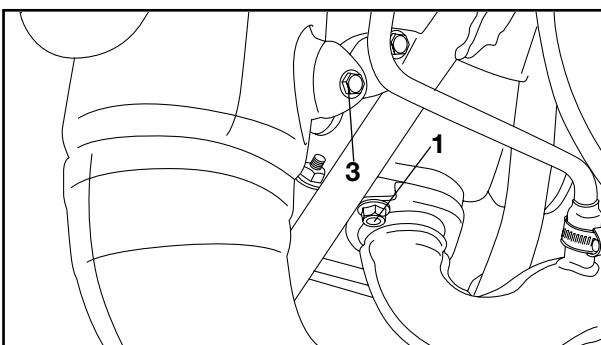
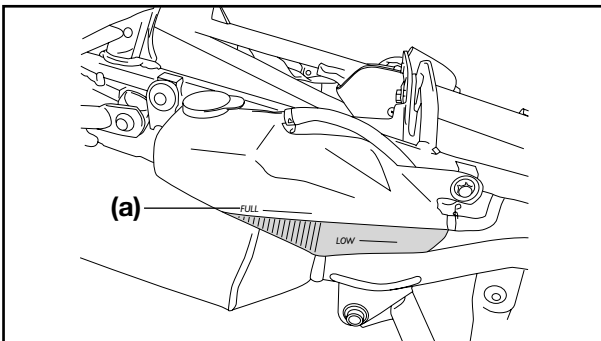

11. Install:
  - radiator cap
12. Fill:
  - coolant reservoir (with the recommended coolant to the maximum level mark @)
13. Install:
  - coolant reservoir cap
14. Start the engine, warm it up for several minutes, and then stop it.
15. Check:
  - coolant levelRefer to "CHECKING THE COOLANT LEVEL".

### NOTE:

Before checking the coolant level, wait a few minutes until the coolant has settled.

16. Install:
  - Exhaust pipe
  - Side covers (left and right)



**Nut ① (Exhaust pipe):**  
18 Nm (1,8 m • kg, 13 ft • lb)

**Bolt ③ (Stay):**  
10 Nm (1,0 m • kg, 7,2 ft • lb)

**Screw ① (Muffler Joint):**  
10 Nm (1,0 m • kg, 7,2 ft • lb)

## COOLING SYSTEM INSPECTION

CHK  
ADJ

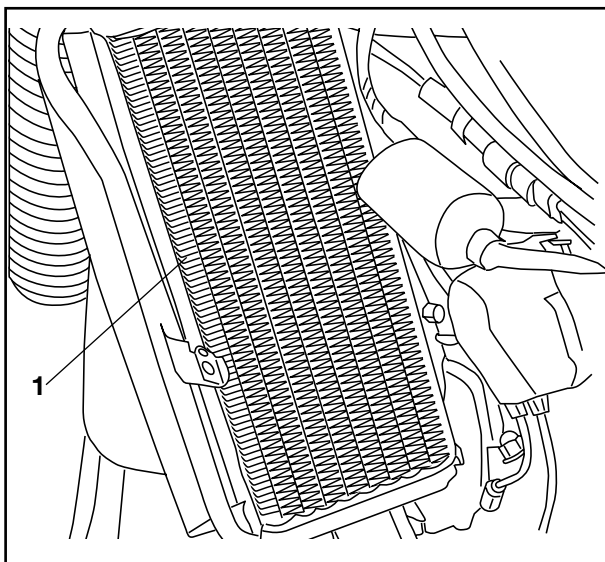

### COOLING SYSTEM INSPECTION

1. Inspect:
  - radiator ①
  - inlet hose
  - outlet hose
  - water outlet pipe ④cracks-damage → Replace  
Refer to the "COOLING SYSTEM" section  
ins CHAPTER 6.

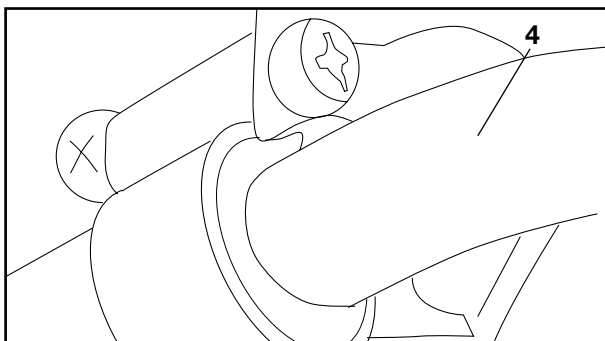

# ADJUSTING THE FRONT BRAKE/ ADJUSTING THE REAR BRAKE

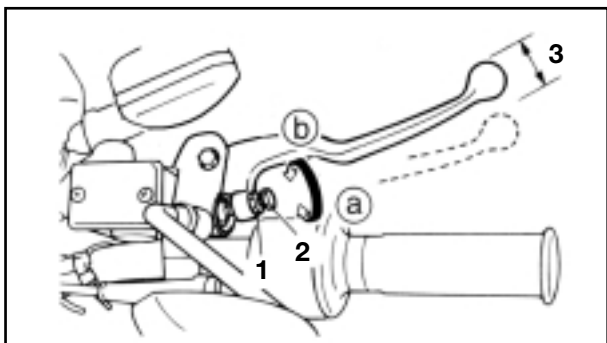

EAS00108

## CHASSIS

### ADJUSTING THE FRONT BRAKE

1. Check:
  - brake lever free play ③
  - Out of specification → Adjust.

	<b>Brake lever free play (at the end of the brake lever)</b> 2 ~ 5mm (0,08 ~ 0,20in)
--	---

2. Adjust:
  - brake lever free play



- a. Loosen the locknut ①.
- b. Turn the adjusting bolt ② in direction ④ or ⑤ until the specified brake lever free play is obtained.

<b>Direction ④</b>	<b>Brake lever free play is increased.</b>
<b>Direction ⑤</b>	<b>Brake lever free play is decreased.</b>

- c. Tighten the locknut.

### **⚠ WARNING**

A soft or spongy feeling in the brake lever can indicate the presence of air in the brake system. Before the vehicle is operated, the air must be removed by bleeding the brake system. Air in the brake system will considerably reduce braking performance and could result in loss of control and possibly an accident. Therefore, check and, if necessary, bleed the brake system.

### **CAUTION**

After adjusting the brake lever free play, make sure there is no brake drag.

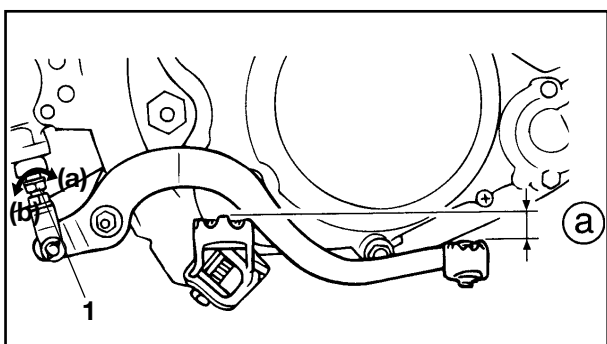

EAS00111

### ADJUSTING THE REAR BRAKE

1. Check:
  - brake pedal position (distance ① from the top of the rider footrest to the top of the brake pedal)
  - Out of specification → Adjust.

	<b>Brake pedal position (below the top of the rider footrest)</b> 15 mm (0,6 in)
--	---

## ADJUSTING THE REAR BRAKE/ CHECKING THE BRAKE FLUID LEVEL

**CHK**  
**ADJ**

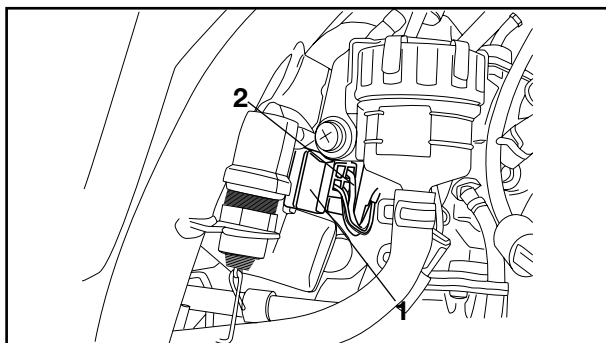

2. Adjust:
- brake pedal position



- a. Loosen the locknut (1).
- b. Turn the adjusting bolt (2) in direction (a) or (b) until the specified brake pedal position is obtained.

Direction (a)	Brake pedal is raised.
Direction (b)	Brake pedal is lowered.

### ⚠ WARNING

After adjusting the brake pedal position, check that the end of the adjusting bolt protrudes 2 mm (0,08 in) from the bottom of the set nut.

- c. Tighten the locknut.

### ⚠ WARNING

A soft or spongy feeling in the brake pedal can indicate the presence of air in the brake system. Before the vehicle is operated, the air must be removed by bleeding the brake system. Air in the brake system will considerably reduce braking performance and could result in loss of control and possibly an accident. Therefore, check and, if necessary, bleed the brake system.

### CAUTION

After adjusting the brake pedal position, make sure there is no brake drag.



3. Adjust:
- rear brake light switch  
Refer to "ADJUSTING THE REAR BRAKE LIGHT SWITCH".

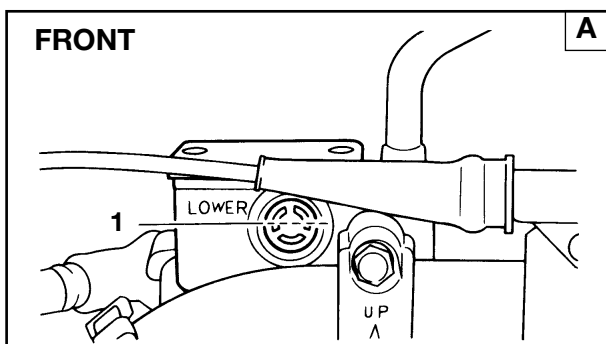

### EAS00115 CHECKING THE BRAKE FLUID LEVEL

1. Stand the motorcycle on a level surface.

### NOTE:

- Place the motorcycle on a suitable stand.
- Make sure the motorcycle is upright.

## CHECKING THE BRAKE FLUID LEVEL

CHK  
ADJ

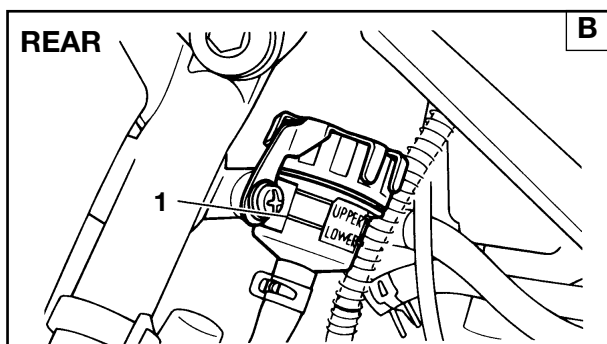

2. Check:

- brake fluid level  
Below the minimum level mark ① → Add the recommended brake fluid to the proper level.



Recommended brake fluid  
DOT 4

- A Front brake
- B Rear brake

### **⚠ WARNING**

- Use only the designated brake fluid. Other brake fluids may cause the rubber seals to deteriorate, causing leakage and poor brake performance.
- Refill with the same type of brake fluid that is already in the system. Mixing brake fluids may result in a harmful chemical reaction, leading to poor brake performance.
- When refilling, be careful that water does not enter the brake fluid reservoir. Water will significantly lower the boiling point of the brake fluid and could cause vapor lock.

### **CAUTION**

Brake fluid may damage painted surfaces and plastic parts. Therefore, always clean up any spilt brake fluid immediately.

### **NOTE:**

In order to ensure a correct reading of the brake fluid level, make sure the top of the brake fluid reservoir is horizontal.







EAS00131

## CHECKING THE FRONT AND REAR BRAKE HOSES

The following procedure applies to all of the brake hoses and brake hose clamps.

1. Check:
  - brake hose  
Cracks/damage/wear → Replace.
2. Check:
  - brake hose clamp  
Loose → Tighten the clamp bolt.
3. Hold the motorcycle upright and apply the brake several times.
4. Check:
  - brake hose  
Brake fluid leakage → Replace the damaged hose.  
Refer to “FRONT AND REAR BRAKES” in chapter 4.

EAS00139

## ADJUSTING THE DRIVE CHAIN SLACK

**NOTE:** \_\_\_\_\_

The drive chain slack must be checked at the tightest point on the chain.

**CAUTION** \_\_\_\_\_

**A drive chain that is too tight will overload the engine and other vital parts, and one that is too loose can skip and damage the swingarm or cause an accident. Therefore, keep the drive chain slack within the specified limits.**

1. Stand the motorcycle on a level surface.

**⚠ WARNING** \_\_\_\_\_

**Securely support the motorcycle so that there is no danger of it falling over.**

**NOTE:** \_\_\_\_\_

Both wheels should be on the ground without a rider on the motorcycle.

2. Move the rear wheel several times and find the tightest position of drive chain.

# ADJUSTING THE DRIVE CHAIN SLACK

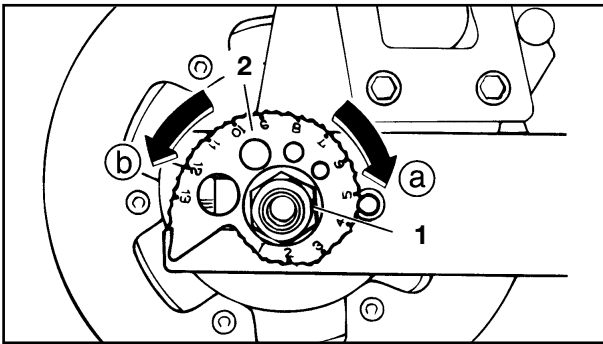
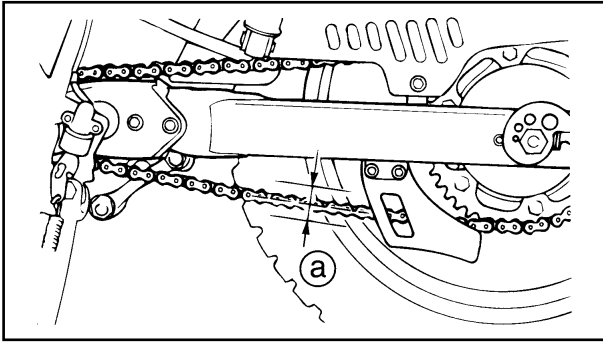

3. Check:
  - drive chain slack ①
  - Out of specification → Adjust.

	<b>Drive chain slack</b> 25 ~ 40 mm (0,9842 ~ 1,5748 in)	DT125X
	45 ~ 55 mm (1,7716 ~ 2,1653 in)	DT125RE

4. Remove:
  - cotter pin
5. Loosen:
  - wheel axle nut ①
6. Adjust:
  - drive chain slack



- a. Loosen both locknuts.
- b. Turn both adjusters ② in direction ① or ② until the specified drive chain slack is obtained.

<b>Direction ①</b>	<b>Drive chain is tightened.</b>
<b>Direction ②</b>	<b>Drive chain is loosened.</b>

**NOTE:** \_\_\_\_\_

- To maintain the proper wheel alignment, adjust both sides evenly.
- Push the rear wheel forward to make sure there is no clearance between the swingarm end plates and the ends of the swingarm.

- c. Tighten the wheel axle nut to specification.

	<b>Wheel axle nut</b> 90 Nm (9.0 m • kg, 65 ft • lb)
--	---

- d. Tighten the locknuts to specification.
- 

7. Install:
  - cotter pin

**⚠ WARNING** \_\_\_\_\_  
Always use a new cotter pin.

**CAUTION** \_\_\_\_\_  
Do not loosen the wheel axle nut after tightening it to the specified torque. If the groove in the wheel axle nut is not aligned with the cotter pin hole in the wheel axle, tighten the nut further until they are aligned.



EAS00142

## LUBRICATING THE DRIVE CHAIN

The drive chain consists of many interacting parts. If the drive chain is not maintained properly, it will wear out quickly. Therefore, the drive chain should be serviced, especially when the motorcycle is used in dusty areas.

This motorcycle has a drive chain with small rubber O-rings between each side plate. Steam cleaning, high-pressure washing, certain solvents, and the use of a coarse brush can damage these O-rings. Therefore, use only kerosene to clean the drive chain. Wipe the drive chain dry and thoroughly lubricate it with engine oil or chain lubricant that is suitable for O-ring chains. Do not use any other lubricants on the drive chain since they may contain solvents that could damage the O-rings.



**Recommended lubricant**  
Engine oil or chain lubricant suitable for O-ring chains

EAS00146

## CHECKING AND ADJUSTING THE STEERING HEAD

1. Stand the motorcycle on a level surface.

### WARNING

**Securely support the motorcycle so that there is no danger of it falling over.**

### NOTE:

Place the motorcycle on a suitable stand so that the front wheel is elevated.

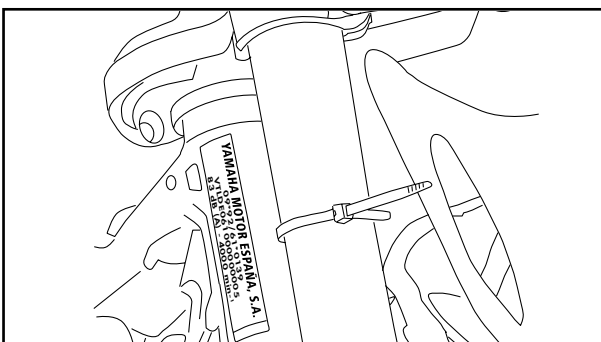
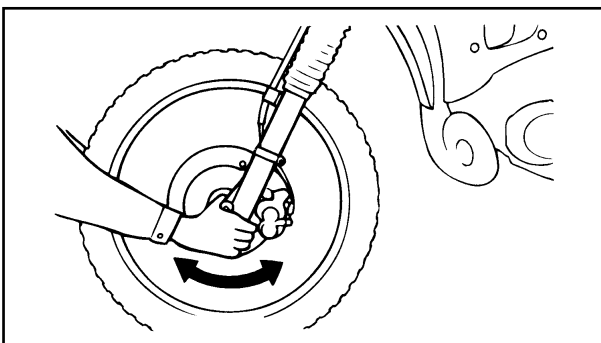

2. Check:
  - steering head  
Grasp the bottom of the front fork legs and gently rock the front fork.  
Binding/looseness → Adjust the steering head.
3. Remove:
  - side covers, seat, fuel tank, main switch protector.  
Remove handlebar from its position.  
Remove handle crown.
4. Adjust:
  - steering head

# CHEEKING AND ADJUSTING THE STEERING HEAD

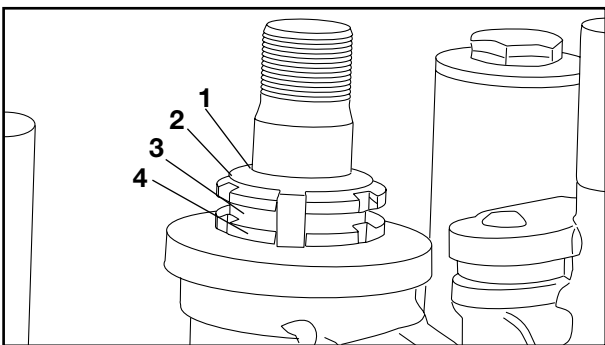
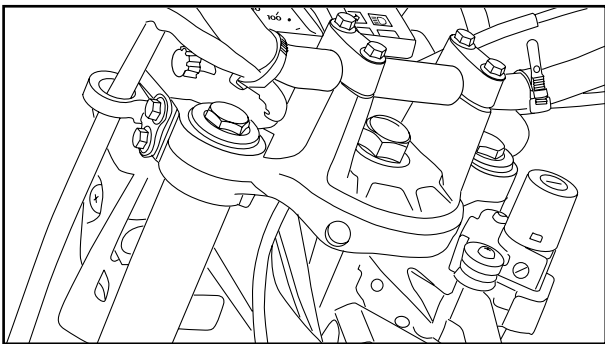

- a. Remove the lock washer ①, the upper ring nut ②, and the rubber washer ③.
- b. Loosen the lower ring nut ④ and then tighten it to specification with a steering nut wrench.

	<b>Steering nut wrench</b> <b>90890-01403</b>
--	--

	<b>Lower ring nut (initial tightening torque)</b> <b>35 Nm (3.5 m • kg, 24.8 ft • lb)</b>
--	--

- c. Loosen the lower ring nut ④ completely, then tighten it to specification.

**▲ WARNING**

**Do not overtighten the lower ring nut.**

	<b>Lower ring nut (final tightening torque)</b> <b>4 Nm (0.4 m • kg, 2.8 ft • lb)</b>
--	--

- d. Check the steering head for looseness or binding by turning the front fork all the way in both directions. If any binding is felt, remove the lower bracket and check the upper and lower bearings. Refer to "STEERING HEAD" in chapter 4.
- e. Install the rubber washer ③.
- f. Install the upper ring nut ②.
- g. Finger tighten the upper ring nut ②, then align the slots of both ring nuts. If necessary, hold the lower ring nut and tighten the upper ring nut until their slots are aligned.
- h. Install the lock washer ①.

**NOTE:**

Make sure the lock washer tabs sit correctly in the ring nut slots.



- 5. Install:
  - Install handle crown
  - Install Handlebars
  - Install side covers, seat, fuel tank, main switch protector.

	<b>Nut Cap</b> <b>120 ~ 155 Nm (12.0 ~ 15.5m•kg, 85.3 ~ 110.1 ft•lb)</b>
--	---

# CHEEKING AND ADJUSTING THE STEERING HEAD/ CHECKING THE FRONT FORK



6. Measure:
- steering head tension



**NOTE:** \_\_\_\_\_

Make sure all of the cables and wires are properly routed.

- Point the front wheel straight ahead.
- Install a plastic locking tie loosely around the end of the handlebar as shown.
- Hook a spring gauge onto the plastic locking tie.
- Hold the spring gauge at a 90° angle from the handlebar, pull the spring gauge, and then record the measurement when the handlebar starts to run.

	<b>Steering head tension</b> <b>200 ~ 250 g</b>
--	--

- Repeat the above procedure on the opposite handlebar.
- If the steering head tension is out of specification (both handlebars should be within specification), remove the upper bracket and loosen or tighten the upper ring nut.
- Reinstall the upper bracket and measure the steering head tension again as described above.
- Repeat the above procedure until the steering head tension is within specification.
- Grasp the bottom of the front fork legs and gently rock the front fork.  
Binding/looseness → Adjust the steering head.



EAS00149

## CHECKING THE FRONT FORK

- Stand the motorcycle on a level surface.

**⚠ WARNING** \_\_\_\_\_

**Securely support the motorcycle so that there is no danger of it falling over.**

# CHECKING THE FRONT FORK/ADJUSTING THE REAR SHOCK ABSORBER ASSEMBLY

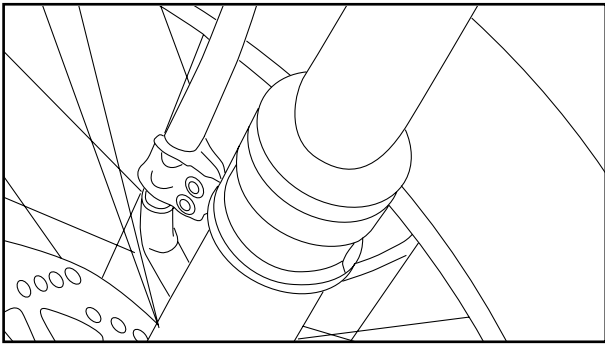

2. Check:
  - inner tube  
Damage/scratches → Replace.
  - oil seal  
Oil leakage → Replace.
3. Hold the motorcycle upright and apply the front brake.

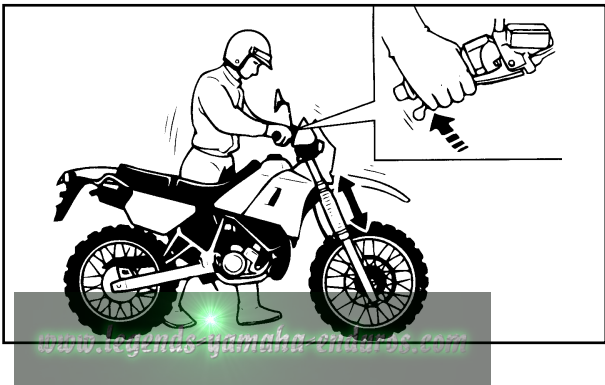

4. Check:
  - front fork operation  
Push down hard on the handlebar several times and check if the front fork rebounds smoothly.  
Rough movement → Repair.  
Refer to "FRONT FORK" in chapter 4.

EAS00156

## ADJUSTING THE REAR SHOCK ABSORBER ASSEMBLY

### **⚠ WARNING**

Securely support the motorcycle so that there is no danger of it falling over.

### Spring preload

### **CAUTION**

Never go beyond the maximum or minimum adjustment positions.

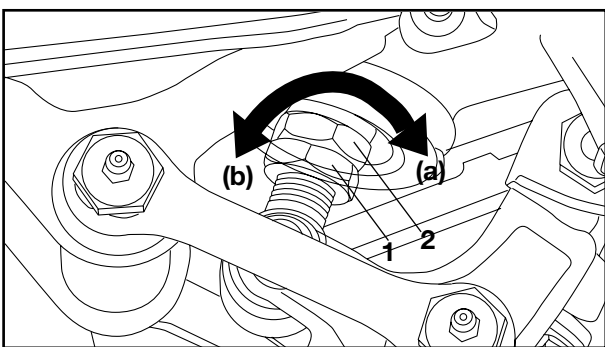

1. Adjust:
  - loosen the locknut ①
  - adjust the spring preload



- a. Adjust the spring preload with a ring nut wrench.

	<b>Ring nut wrench</b> 90890-01268
--	---------------------------------------

- b. Turn the adjusting ring ② in direction (a) or (b).

<b>Direction (a)</b>	<b>Spring preload is increased (suspension is harder)</b>
<b>Direction (b)</b>	<b>Spring preload is decreased (suspension is softer).</b>

Adjusting positions		
Minimum	Standard	Maximum
220 mm	230 mm	235 mm





2. Tighten:
  - Tighten the locknut

EAS00164

## CHECKING THE TIRES

The following procedure applies to both of the tires.

1. Check:
  - tire pressure  
Out of specification → Regulate.

### **WARNING**

- The tire pressure should only be checked and regulated when the tire temperature equals the ambient air temperature.
- The tire pressure and the suspension must be adjusted according to the total weight (including cargo, rider, passenger and accessories) and the anticipated riding speed.
- Operation of an overloaded motorcycle could cause tire damage, an accident or an injury.

**NEVER OVERLOAD THE MOTORCYCLE.**

#### Tire air pressure (measured on cold tires):

##### **DT125R**

##### **Up to 90 kg (198 lb):**

Front:

150 kPa (21,8 psi) (1,5 kgf/cm<sup>2</sup>)

Rear:

175 kPa (25,4 psi) (1,75 kgf/cm<sup>2</sup>)

##### **90 kg (198 lb) to maximum load:**

Front:

175 kPa (25,4 psi) (1,75 kgf/cm<sup>2</sup>)

Rear:

200 kPa (28,9 psi) (2 kgf/cm<sup>2</sup>)

##### **Maximum load\*:**

178 kg (392 lb)

##### **DT125X**

##### **Up to 90 kg (198 lb):**

Front:

180 kPa (26,1 psi) (1,8 kgf/cm<sup>2</sup>)

Rear:

200 kPa (28,9 psi) (2 kgf/cm<sup>2</sup>)

##### **90 kg (198 lb) to maximum load:**

Front:

180 kPa (26,1 psi) (1,8 kgf/cm<sup>2</sup>)

Rear:

200 kPa (28,9 psi) (2 kgf/cm<sup>2</sup>)

##### **Maximum load\*:**

180 kg (396 lb)

\* Total weight of rider, passenger, cargo and accessories



**⚠ WARNING**

It is dangerous to ride with a worn-out tire. When the tire tread reaches the wear limit, replace the tire immediately.

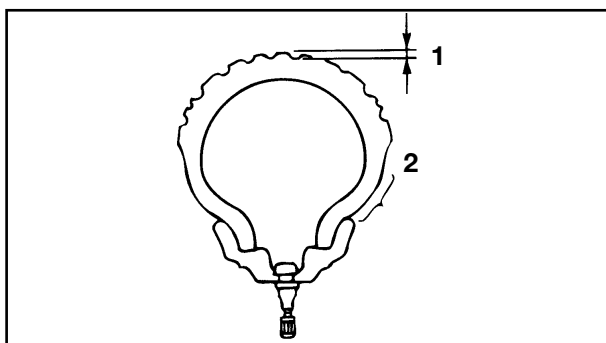

2. Check:
- tire surfaces
- Damage/wear → Replace the tire.



**Minimum tire tread depth  
1.6 mm (0.04 in)**

- ① Tire tread depth
- ② Sidewall

**⚠ WARNING**

- Do not use a tubeless tire on a wheel designed only for tube tires to avoid tire failure and personal injury from sudden deflation.
- When using tube tires, be sure to install the correct tube.
- Always replace a new tube tire and a new tube as a set.
- To avoid pinching the tube, make sure the wheel rim band and tube are centered in the wheel groove.
- Patching a punctured tube is not recommended. If it is absolutely necessary to do so, use great care and replace the tube as soon as possible with a good quality replacement.

Tube wheel	Tube tire only
Tubeless wheel	Tube or tubeless tire

**⚠ WARNING**

- After extensive tests, the tires listed below have been approved by Yamaha Motor España, S.A. for this model. The front and rear tires should always be by the same manufacturer and of the same design. No guarantee concerning handling characteristics can be given if a tire combination other than one approved by Yamaha is used on this motorcycle.



# CHECKING THE TIRES/ CHECKING AND TIGHTENING THE SPOKES

CHK  
ADJ



## Front tire

Manufacturer

	Model	Size
DT125RE	MICHELIN T63	80/90-21 48P
DT125X	PIRELLI Sport Demon	120/70-17 58H

## Rear tire

Manufacturer

	Model	Size
DT125RE	MICHELIN T63	110/80-18 58P
DT125X	PIRELLI Sport Demon	140/70-17 66H

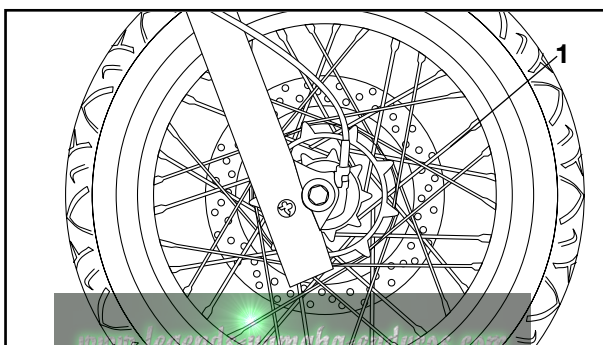
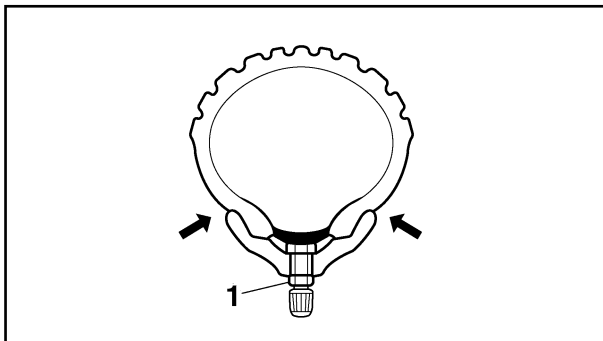

## ⚠ WARNING

- New tires have a relatively low grip on the road surface until they have been slightly worn. Therefore, approximately 100 km should be traveled at normal speed before any high-speed riding is done.
- After a tire has been repaired or replaced, be sure to tighten the tire air valve stem nut ① and locknut ② to specification.



Tire air valve stem (front wheel only)

Valve stem lock nut  
1.5 Nm (0.15 m•kg, 1.1 ft•lb)

EAS00169

## CHECKING AND TIGHTENING THE SPOKES

The following procedure applies to all of the spokes.

1. Check:
  - spoke ①  
Bends/damage → Replace.  
Loose → Tighten.  
Tap the spokes with a screwdriver.

## NOTE:

A tight spoke will emit a clear, ringing tone; a loose spoke will sound flat.

## CHECKING AND TIGHTENING THE SPOKES/ CHECKING AND LUBRICATING THE CABLES

CHK  
ADJ



2. Tighten:
  - spoke  
(with a spoke wrench)



2~3.5 Nm (0.2~0.35 m•kg,  
1.42~2.49 ft•lb)

**NOTE:** \_\_\_\_\_

Be sure to tighten the spokes before and after break-in.

---

EAS00170

### CHECKING AND LUBRICATING THE CABLES

The following procedure applies to all of the inner and outer cables.

**⚠ WARNING** \_\_\_\_\_

**Damaged outer cable may cause the cable to corrode and interfere with its movement. Replace damaged outer cable and inner cables as soon as possible.**

---

1. Check:
  - outer cable  
Damage → Replace.
2. Check:
  - cable operation  
Rough movement → Lubricate.



**Recommended lubricant  
SAE 10W30 Motor Oil**

**NOTE:** \_\_\_\_\_

Hold the cable end upright and pour a few drops of lubricant into the cable sheath or use a suitable lubricating device.

---

# LUBRICATING THE LEVERS AND PEDALS/LUBRICATING THE SIDESTAND/LUBRICATING THE REAR SUSPENSION

**CHK**  
**ADJ**



EAS00171

**LUBRICATING THE LEVERS AND PEDALS**  
Lubricate the pivoting point and metal-to-metal moving parts of the levers and pedals.



**Recommended lubricant**  
**SAE 10W30 Motor Oil**

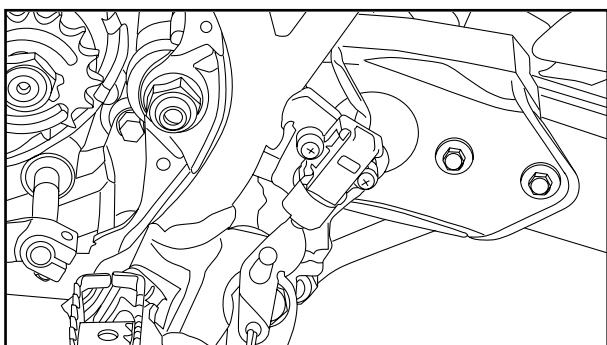

EAS00172

**LUBRICATING THE SIDESTAND**  
Lubricate the pivoting point and metal-to-metal moving parts of the sidestand.



**Recommended lubricant**  
**SAE 10W30 Motor Oil**

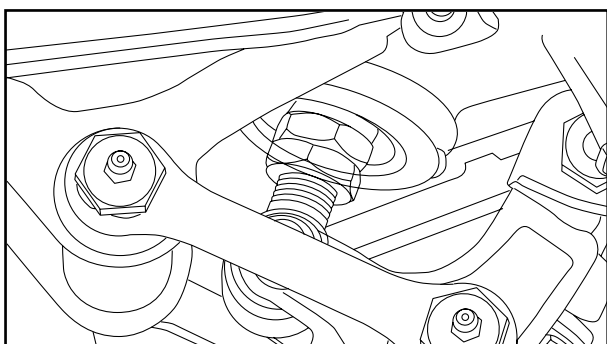

EAS00174

**LUBRICATING THE REAR SUSPENSION**  
Lubricate the pivoting point and metal-to-metal moving parts of the rear suspension.



**Recommended lubricant**  
**Molybdenum disulfide grease**

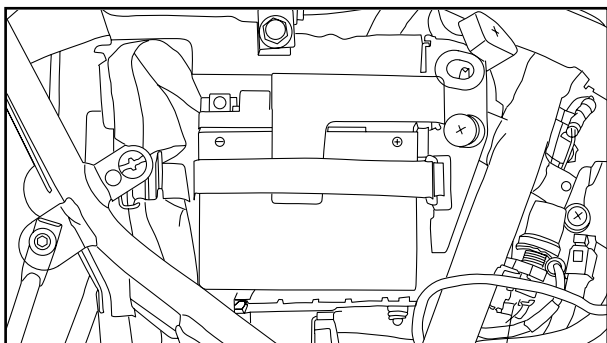

EAS00178

**ELECTRICAL SYSTEM****CHECKING AND CHARGING THE BATTERY****WARNING**

Batteries generate explosive hydrogen gas and contain electrolyte which is made of poisonous and highly caustic sulfuric acid. Therefore, always follow these preventive measures:

- Wear protective eye gear when handling or working near batteries.
- Charge batteries in a well-ventilated area.
- Keep batteries away from fire, sparks or open flames (e.g., welding equipment, lighted cigarettes).
- **DO NOT SMOKE** when charging or handling batteries.
- **KEEP BATTERIES AND ELECTROLYTE OUT OF REACH OF CHILDREN.**
- Avoid bodily contact with electrolyte as it can cause severe burns or permanent eye injury.

**FIRST AID IN CASE OF BODILY CONTACT:****EXTERNAL**

- Skin <—> Wash with water.
- Eyes <—> Flush with water for 15 minutes and get immediate medical attention.

**INTERNAL**

- Drink large quantities of water or milk followed with milk of magnesia, beaten egg or vegetable oil. Get immediate medical attention.

**CAUTION**

- This is a sealed battery. Never remove the sealing caps because the balance between cells will not be maintained and battery performance will deteriorate.
- Charging time, charging amperage and charging voltage for an MF battery are different from those of conventional batteries. The MF battery should be charged as explained in the charging method illustrations. If the battery is overcharged, the electrolyte level will drop considerably. Therefore, take special care when charging the battery.

**NOTE:** \_\_\_\_\_

Since MF batteries are sealed, it is not possible to check the charge state of the battery by measuring the specific gravity of the electrolyte. Therefore, the charge of the battery has to be checked by measuring the voltage at the battery terminals.

1. Remove:
  - Rear side cover (right)
  - Battery cover
2. Disconnect:
  - battery leads (from the battery terminals)

**CAUTION** \_\_\_\_\_

**First, disconnect the negative battery lead ①, and then the positive battery lead ②.**

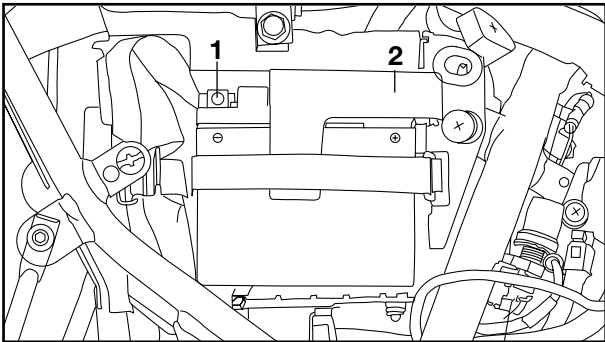

3. Remove:
  - battery

4. Check:
  - battery charge



- a. Connect a pocket tester to the battery terminals.

**Positive tester probe → positive battery terminal.**  
**Negative tester probe → negative battery terminal.**

**NOTE:** \_\_\_\_\_

- The charge state of an MF battery can be checked by measuring its open-circuit voltage (i.e., the voltage when the positive battery terminal is disconnected).
- No charging is necessary when the open-circuit voltage equals or exceeds 12.8 V.

- b. Check the charge of the battery, as shown in the charts and the following example.

**Example**

- c. Open-circuit voltage = 12.0 V
- d. Charging time = 6.5 hours
- e. Charge of the battery = 20 ~ 30%



5. Charge:
  - battery



### WARNING

Do not quick charge a battery.

### CAUTION

- Never remove the MF battery sealing caps.
- Do not use a high-rate battery charger since it forces a high-amperage current into the battery quickly and can cause battery overheating and battery plate damage.
- If it is impossible to regulate the charging current on the battery charger, be careful not to overcharge the battery.
- When charging a battery, be sure to remove it from the motorcycle. (If charging has to be done with the battery mounted on the motorcycle, disconnect the negative battery lead from the battery terminal.)
- To reduce the chance of sparks, do not plug in the battery charger until the battery charger leads are connected to the battery.
- Before removing the battery charger lead clips from the battery terminals, be sure to turn off the battery charger.
- Make sure the battery charger lead clips are in full contact with the battery terminal and that they are not shorted. A corroded battery charger lead clip may generate heat in the contact area and a weak clip spring may cause sparks.
- If the battery becomes hot to the touch at any time during the charging process, disconnect the battery charger and let the battery cool before reconnecting it. Hot batteries can explode!
- As shown in the following illustration, the open-circuit voltage of an MF battery stabilizes about 30 minutes after charging has been completed. Therefore, wait 30 minutes after charging is completed before measuring the open-circuit voltage.

Charging method using a variable-current (voltage) charger

Charging method using a constant voltage charger

6. Install:
  - battery
7. Connect:
  - battery leads  
(to the battery terminals)



## CHECKING THE FUSES/ REPLACING THE HEADLIGHT BULB

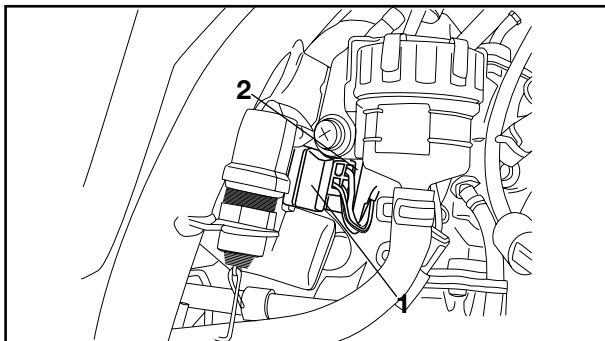

3. Replace:
  - blown fuse



- a. Set the main switch to "OFF".
- b. Install a new fuse of the correct amperage rating.
- c. Set on the switches to verify if the electrical circuit is operational.
- d. If the fuse immediately blows again, check the electrical circuit.

Fuses	Amperage rating	Q'ty
Main	15A	1
Reserve	15A	1

### WARNING

Never use a fuse with an amperage rating other than that specified. Improvising or using a fuse with the wrong amperage rating may cause extensive damage to the electrical system, cause the lighting and ignition systems to malfunction and could possibly cause a fire.



4. Install:
  - Rear side cover (right).

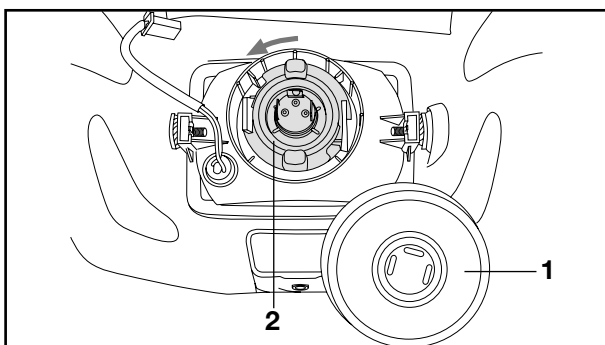

EAS00182

### REPLACING THE HEADLIGHT BULB

1. Remove front cowling
2. Disconnect:
  - Couplers
3. Remove headlight bulb cover ①
4. Remove the headlight bulb holder according to the drawing, then remove the defective bulb ②

### WARNING

Since the headlight bulb gets extremely hot, keep flammable products and your hands away from the bulb until it has cooled down.



## REPLACING THE HEADLIGHT BULB/ ADJUSTING THE HEADLIGHT BEAM

CHK  
ADJ



5. Install:
  - headlight bulbNewSecure the new headlight bulb with the headlight bulb holder.

### CAUTION

**Avoid touching the glass part of the headlight bulb to keep it free from oil, otherwise the transparency of the glass, the life of the bulb and the luminous flux will be adversely affected. If the headlight bulb gets soiled, thoroughly clean it with a cloth moistened with alcohol or lacquer thinner.**

6. Install:
  - headlight bulb holder
7. Install:
  - headlight bulb cover
8. Connect:
  - Front cowling

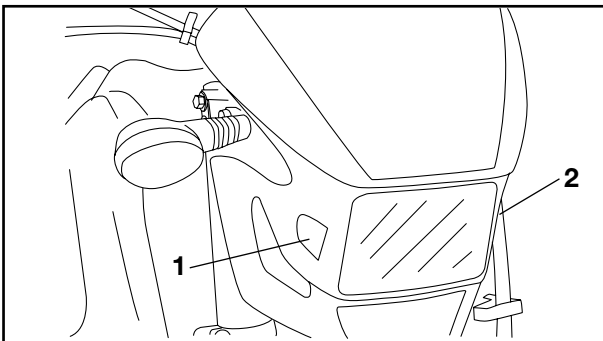

EAS00184

### ADJUSTING THE HEADLIGHT BEAM

1. Adjust:
  - headlight beam (vertically)
  - a. Loosen screws ① and ②
  - b. Adjust the headlight vertically
  - c. Tighten screw ① and ②



**CHAS**

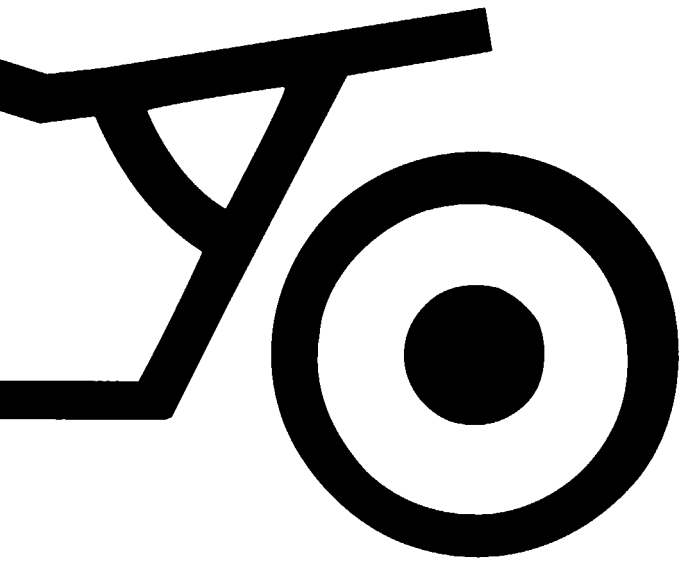

4



## CHAPTER 4 CHASSIS

<b>FRONT WHEEL</b> .....	4-1
REMOVAL .....	4-2
INSPECTION .....	4-3
INSTALLATION .....	4-5
<b>REAR WHEEL</b> .....	4-7
REMOVAL .....	4-8
INSPECTION .....	4-9
INSTALLATION .....	4-9
<b>FRONT AND REAR BRAKE</b> .....	4-11
BRAKE PAD REPLACEMENT .....	4-13
CALIPER DISASSEMBLY .....	4-18
MASTER CYLINDER DISASSEMBLY .....	4-19
INSPECTION AND REPAIR .....	4-23
ASSEMBLY .....	4-27
AIR BLEEDING .....	4-35
<b>FRONT FORK</b> .....	4-37
REMOVAL .....	4-38
DISASSEMBLY .....	4-38
INSPECTION .....	4-40
ASSEMBLY .....	4-41
<b>STEERING HEAD AND HANDLEBAR</b> .....	4-45
REMOVAL .....	4-46
INSPECTION .....	4-49
INSTALLATION .....	4-50
<b>REAR SHOCK ABSORBER AND SWINGARM</b> .....	4-55
HANDLING NOTES .....	4-57
NOTES ON DISPOSAL .....	4-57
REMOVAL .....	4-57
INSPECTION .....	4-62
SIDE CLEARANCE ADJUSTMENT .....	4-62
INSTALLATION .....	4-64
<b>DRIVE CHAIN AND SPROCKETS</b> .....	4-66
REMOVAL .....	4-67
INSPECTION .....	4-68
INSTALLATION .....	4-70

CHASSIS

FRONT WHEEL

- ① Hub
- ② Bearing
- ③ Collar
- ④ Oil Seal
- ⑤ Rim
- ⑥ Spoke
- ⑦ Cap
- ⑧ Collar
- ⑨ Dust cover
- ⑩ Wheel axle
- ⑪ Cap
- ⑫ Gear unit (speedometer)

Basic weight: With oil and full fuel tank	DT125RE 126 kg	DT125X 134 kg	<b>DT125RE</b>	
Maximum load*	178 kg (392 lb)	180 kg (396 lb)	A	Tire Size: 80/90-21 48P
Cold tire pressure			B	Rim Size: 21x1.60
Up to 90 Kg (198 bf) load*	150kPa (1,5kgf/cm <sup>2</sup> )(21,8psi)	180Kpa (1,8kgf/cm <sup>2</sup> )(26,1psi)	C	Rim Runout Limit: Vertical: 1,0 mm (0,08 in) Lateral: 0,5 mm (0,02 in)
90kg (198lbf)-Maximum load	175kPa (1,75kgf/cm <sup>2</sup> )(25,4psi)	180Kpa (1,8kgf/cm <sup>2</sup> )(26,1psi)		
Off-road riding	150kPa (1,5kgf/cm <sup>2</sup> )(21,8psi)	—		

<b>DT125X</b>	
A	Tire Size: 120/70/17 58H
B	Rim Size: 17x3.00
C	Rim Runout Limit: Vertical: 1,0 mm (0,08 in) Lateral: 0,5 mm (0,02 in)

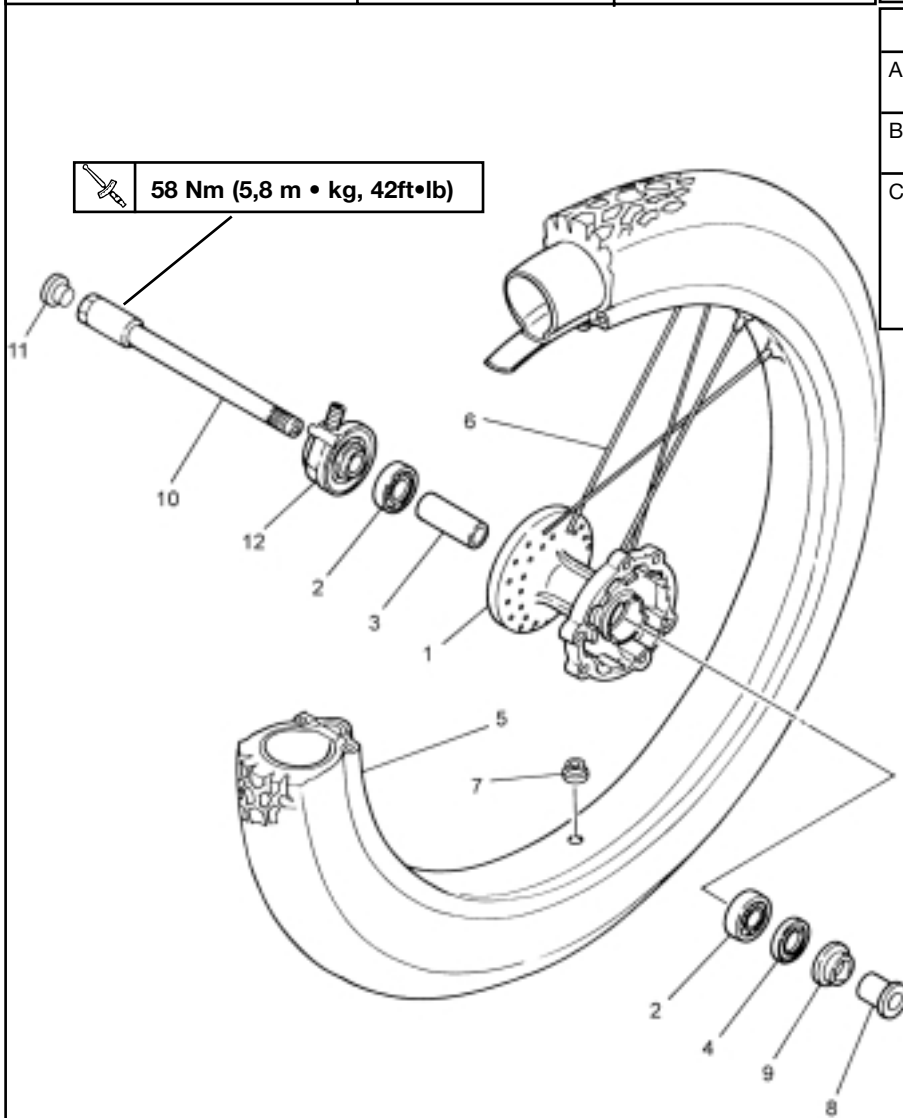

## REMOVING THE FRONT WHEEL

CHAS



EAS00519

### REMOVING THE FRONT WHEEL

1. Stand the motorcycle on a level surface.

#### **⚠ WARNING**

Securely support the motorcycle so that there is no danger of it falling over.

#### **NOTE:**

Place the motorcycle on a suitable stand so that the front wheel is elevated.

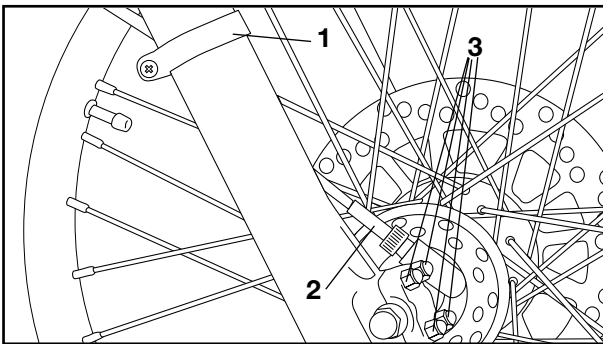

2. Remove:
  - Cable holder (speedometer) ①
3. Disconnect:
  - Speedometer cable ②
4. Loosen:
  - Nuts (Axle holder) ③

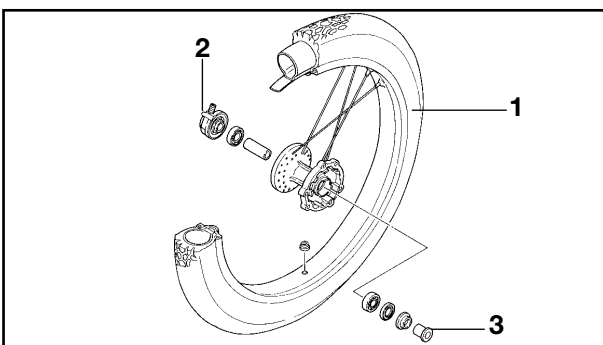

5. Remove:
  - Front wheel axle
  - Front wheel ①
  - Gear unit (speedometer) ②
  - Spacer collar ③

#### **NOTE:**

Do not apply the brake lever when removing the brake caliper.

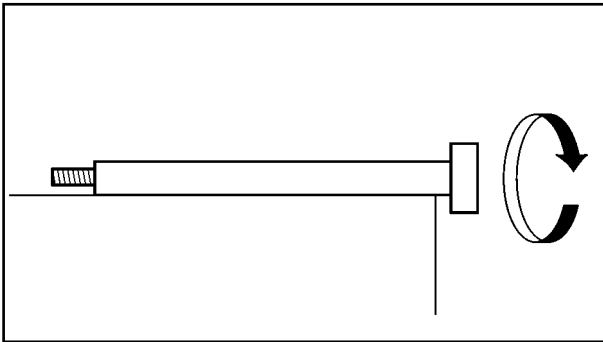

EAS00526

## CHECKING THE FRONT WHEEL

### 1. Check:

- wheel axle  
Roll the wheel axle on a flat surface.  
Bends → Replace.

### **⚠ WARNING**

**Do not attempt to straighten a bent wheel axle.**

### 2. Check:

- tire
- front wheel  
Damage/wear → Replace.  
Refer to “CHECKING THE TIRES” and “CHECKING THE WHEELS” in chapter 3.

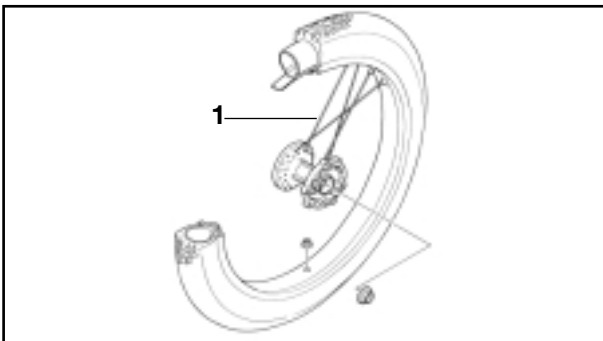

### 3. Check:

- spokes ①  
Bends/damage → Replace.  
Loose → Tighten.  
Tap the spokes with a screwdriver.

### **NOTE:**

A tight spoke will emit a clear, ringing tone, a loose spoke will sound flat.

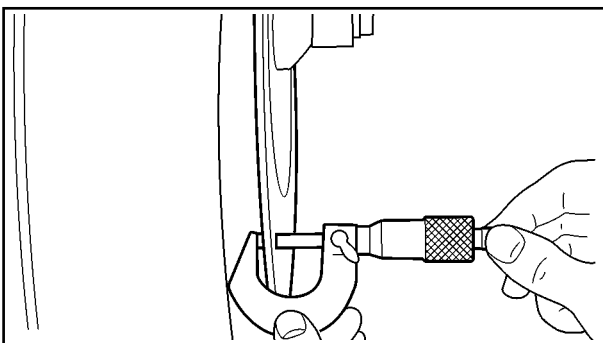

### 4. Tighten:

- spokes



**2~3.5 Nm (0.2~0.35 m•kg,  
1.42~2.49 ft•lb)**

### **NOTE:**

After tightening the spokes, measure the front wheel runout.

### 5. Measure:

- front wheel radial runout
- front wheel lateral runout  
Over the specified limits → Replace.



**Front wheel radial runout limit  
1 mm (0.04 in)  
Front wheel lateral runout limit  
0.5 mm (0.02 in)**

## CHECKING THE FRONT WHEEL

CHAS

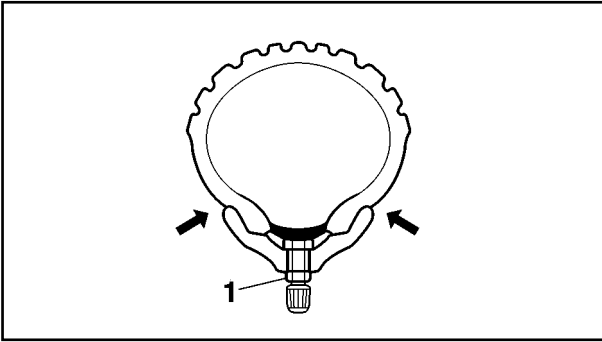

6. Check:
- collars  
Damage/wear → Replace.

### **⚠ WARNING**

- After mounting a new tire, ride conservatively for a while to become accustomed to the “feel” of the new tire and to allow the tire to seat itself properly in the rim. Failure to do so could lead to an accident with possible injury to the rider or damage to the motorcycle.
- After a tire has been repaired or replaced, be sure to tighten the tire air valve stem locknut ① to specification.



**Tire air valve stem locknut**  
**1.5 Nm (0.15 m•kg, 1.1 ft•lb)**

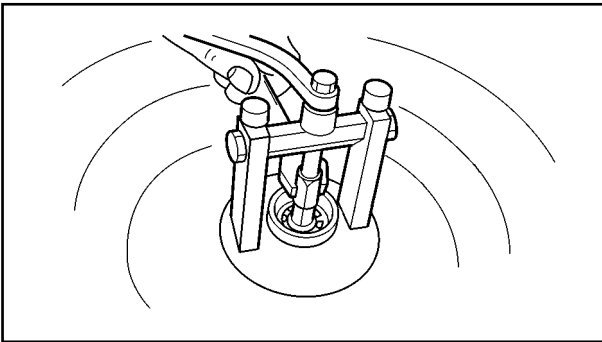

7. Check:
- wheel bearings  
Front wheel turns roughly or is loose → Replace the wheel bearings.
  - oil seals  
Damage/wear → Replace.

8. Replace:
- wheel bearings **New**
  - oil seals **New**



- a. Clean the outside of the front wheel hub.
- b. Remove the oil seals with a flat-head screwdriver.

### **NOTE:**

To prevent damaging the wheel, place a rag between the screwdriver and the wheel surface.

- c. Remove the wheel bearings with a general bearing puller.
- d. Install the new wheel bearings and oil seals in the reverse order of disassembly.



# CHECKING THE FRONT WHEEL/ INSTALLING THE FRONT WHEEL

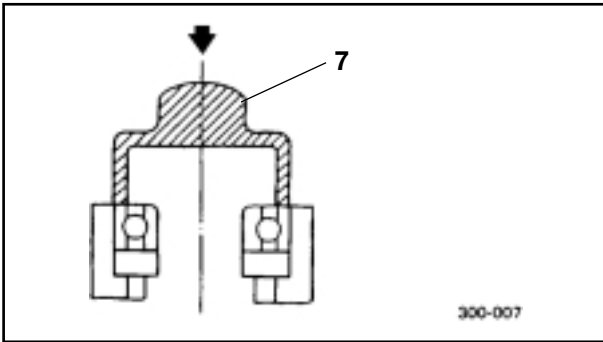

## CAUTION

Do not contact the wheel bearing inner race or balls. Contact should be made only with the outer race.

## NOTE:

Use a socket ⑦ that matches the diameter of the wheel bearing outer race and oil seal.

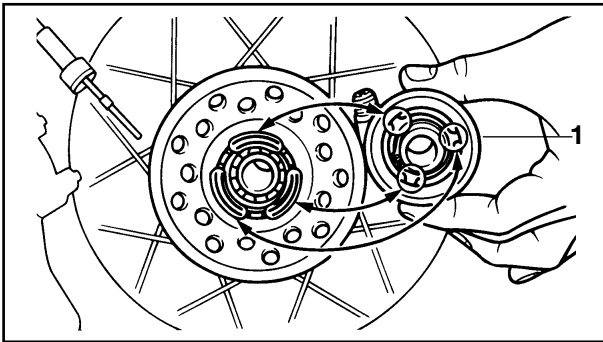

## EAS00542 INSTALLING THE FRONT WHEEL

1. Lubricate:
  - wheel axle
  - wheel bearings
  - oil seal lips
  - speedometer drive gear
  - speedometer driven gear

	<b>Recommended lubricant</b> <b>Lithium-soap-based grease</b>
--	--

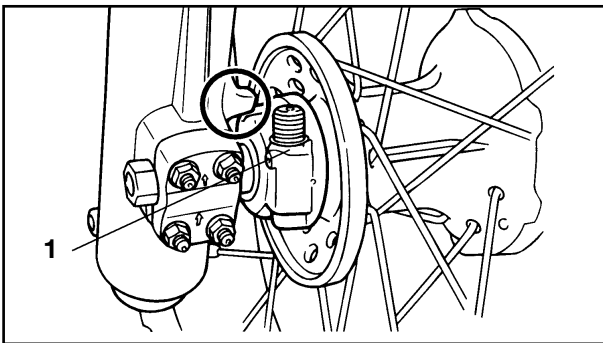

2. Install:
  - speedometer gear unit ①

## NOTE:

Make sure the speedometer gear unit and the wheel hub are installed with the two projections meshed into the two slots respectively.

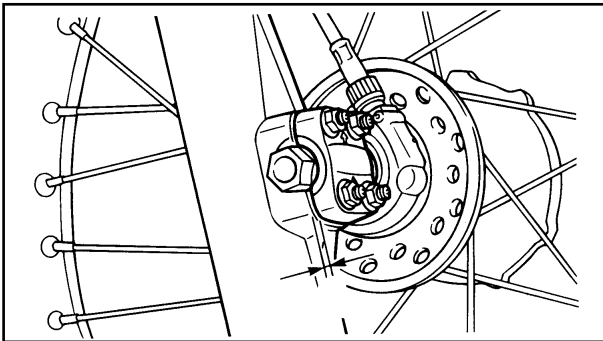

3. Install:
  - front wheel

## NOTE:

Make sure the slot in the speedometer gear unit fits over the stopper on the outer tube.

## INSTALLING THE FRONT WHEEL

CHAS



### 4. Tighten:

- wheel axle



45~70 Nm (4.5~7.0 m•kg, 33~51.3 ft•lb)

- Nut (Axle holder):



7.5~12 Nm (0.75~1.2 m•kg,  
5.5~8.8 ft•lb)

### **WARNING**

Make sure the brake cable is routed properly.

### **CAUTION**

Before tightening the wheel axle nut, push down hard on the handlebar several times and check if the front fork rebounds smoothly.



## REAR WHEEL

- |            |                   |                |
|------------|-------------------|----------------|
| ① Hub      | ⑧ Driven Sprocket | ⑮ Chain puller |
| ② Collar   | ⑨ Bolt            | ⑯ Chain puller |
| ③ Bearing  | ⑩ Nut             | ⑰ Wheel axle   |
| ④ Oil Seal | ⑪ Collar          | ⑱ Washer       |
| ⑤ Rim      | ⑫ Dust Cover      | ⑲ Nut          |
| ⑥ Spoke    | ⑬ Collar          | ⑳ Drive chain  |
| ⑦ Cap      | ⑭ Oil Seal        |                |

Basic weight: With oil and full fuel tank	DT125RE 126 kg	DT125X 134 kg	<b>DT125RE</b>	
Maximum load*	178 kg (392 lb)	180 kg (396 lb)	A	Tire Size: 110/80-18 58P
Cold tire pressure			B	Rim Size: 18 x 1,85
Up to 90 Kg (198 bf) load*	175kPa (1,75kgf/cm <sup>2</sup> )(25,4psi)	200Kpa (2,0kgf/cm <sup>2</sup> )(28,9psi)	C	Rim Runout: Vertical: 1,0 mm (0,08 in) Lateral: 0,5 mm (0,02 in)
90kg (198lbf)~Maximum load	200kPa (2,0kgf/cm <sup>2</sup> )(28,9psi)	200Kpa (2,0kgf/cm <sup>2</sup> )(28,9psi)		
Off-road riding	175kPa (1,75kgf/cm <sup>2</sup> )(25,4psi)	—		

<b>DT125X</b>				
A	Tire Size: 140/70-17 66H			
B	Rim Size: 17x3.50			
C	Rim Runout Limit: Vertical: 1,0 mm (0,08 in) Lateral: 0,5 mm (0,02 in)			

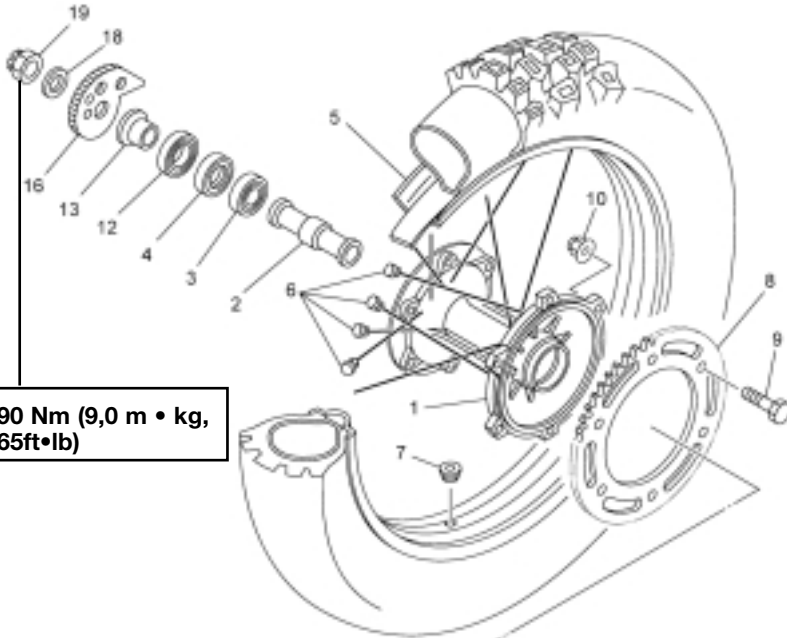

**90 Nm (9,0 m • kg, 65ft•lb)**

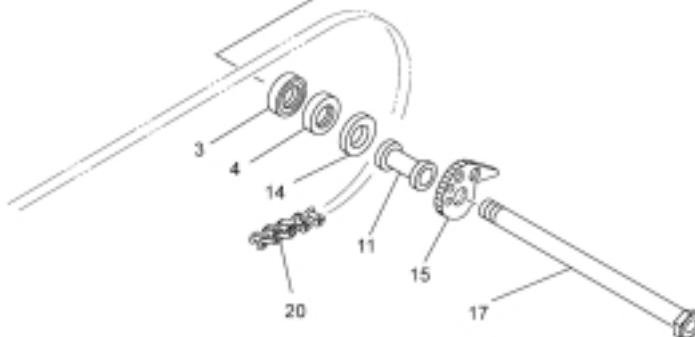

## REMOVING THE REAR WHEEL

CHAS



EAS00561

### REMOVING THE REAR WHEEL

1. Stand the motorcycle on a level surface.

#### **⚠ WARNING**

Securely support the motorcycle so that there is no danger of it falling over.

#### **NOTE:**

Place the motorcycle on a suitable stand so that the rear wheel is elevated.

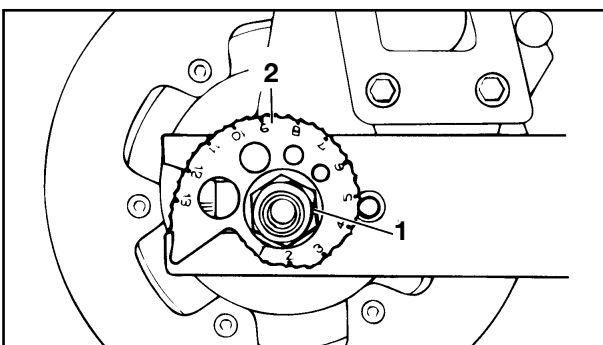
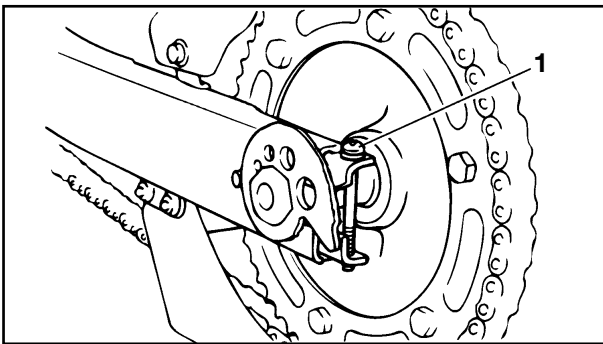
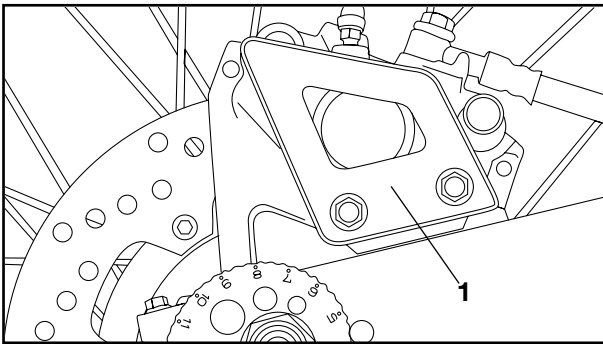

2. Remove:
  - rear brake caliper protection ①

#### **NOTE:**

Do not depress the brake pedal when removing the brake caliper.

3. Loosen:
  - bolts (swingarm end).

4. Remove:
  - wheel axle nut ①
  - wheel axle
  - rear wheel

#### **NOTE:**

Push the rear wheel forward and remove the drive chain from the rear wheel sprocket.

## INSPECTING THE REAR WHEEL/ INSTALLING THE REAR WHEEL

CHAS

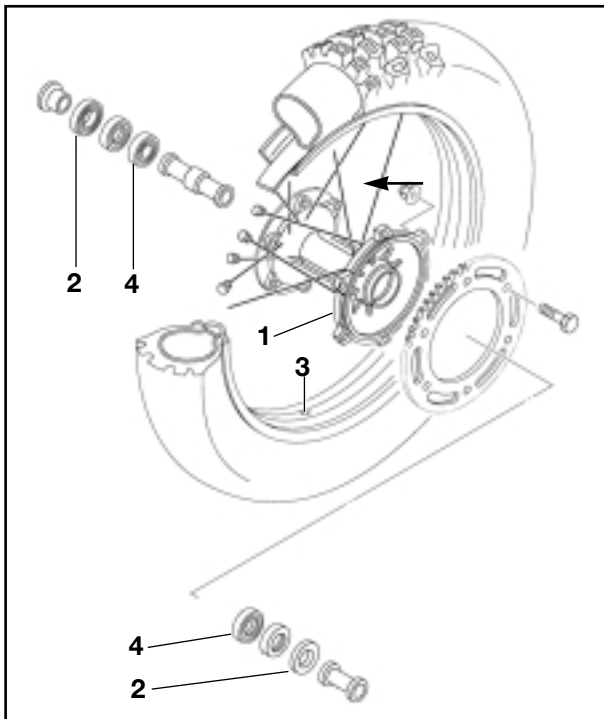

### INSPECTING THE REAR WHEEL

1. Inspect:
  - Rear wheel axle  
Refer to the "FRONT WHEEL - INSPECTION" section.
2. Inspect:
  - Wheel hub ①
  - Dust covers (Bearings) ②
  - Wheel ③  
Refer to the "FRONT WHEEL - INSPECTION" section.
3. Measure:
  - Wheel runout  
Refer to the "FRONT WHEEL - INSPECTION" section.
4. Check:
  - Wheel bearings ④  
Refer to the "FRONT WHEEL - INSPECTION" section.
5. Check:
  - Wheel balance  
Refer to the "FRONT WHEEL - INSPECTION" section.

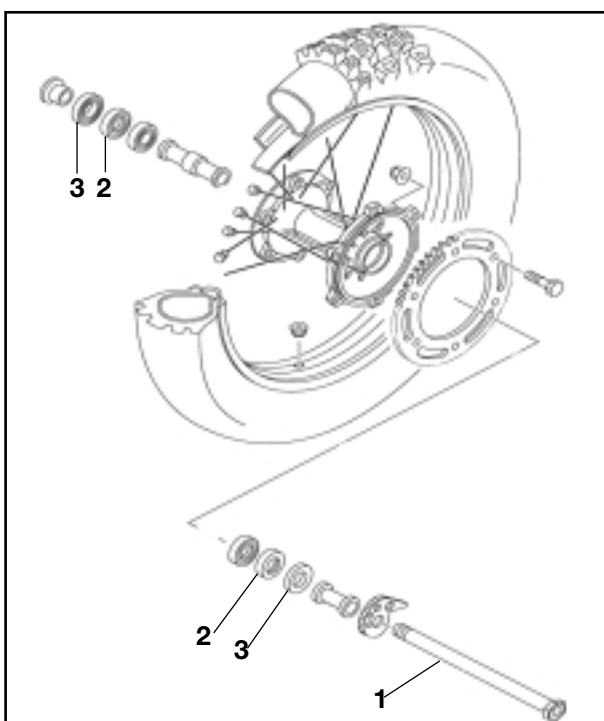

EAS00572

### INSTALLING THE REAR WHEEL

When installing the rear wheel, reverse the removal procedure. Note the following points:

1. Lubricate:
  - wheel axle ①
  - wheel bearings
  - oil seal lips ②

## INSTALLING THE REAR WHEEL

CHAS

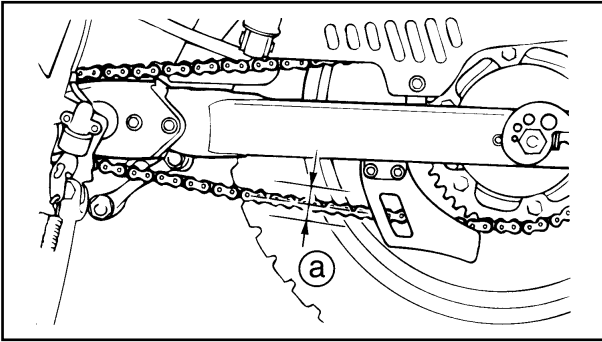

### 2. Adjust:

- Drive chain slack @



#### Drive chain slack:

DT125RE 40~55mm (1,77~2,16in.)  
DT125X 25~40mm (0,98~1,58 in.)

- Refer to the "DRIVE CHAIN SLACK ADJUSTMENT" section in CHAPTER 3.



#### Recommended lubricant

Lithium-soap-based grease

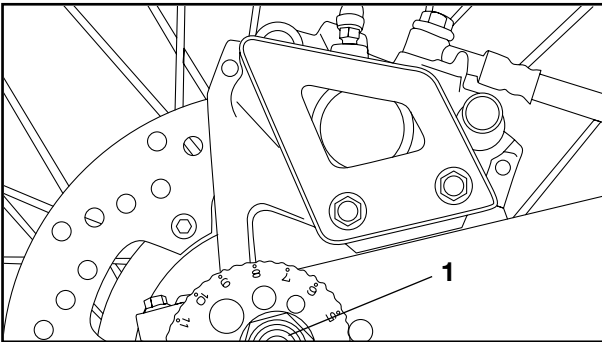

### 3. Tighten:

- wheel axle nut ①
- bolts (swingarm end)



30 Nm (3 m•kg, 22 ft•lb)



80~100Nm (8.0~10.0 m•kg,  
58.7~73.3 ft•lb)



## FRONT AND REAR BRAKE

- ① Master cylinder cap
- ② Diaphragm
- ③ Master cylinder kit
- ④ Master cylinder
- ⑤ Brake hose
- ⑥ Brake caliper
- ⑦ Pad spring
- ⑧ Piston
- ⑨ Piston seal
- ⑩ Dust seal
- ⑪ Brake pad
- ⑫ Brake disc

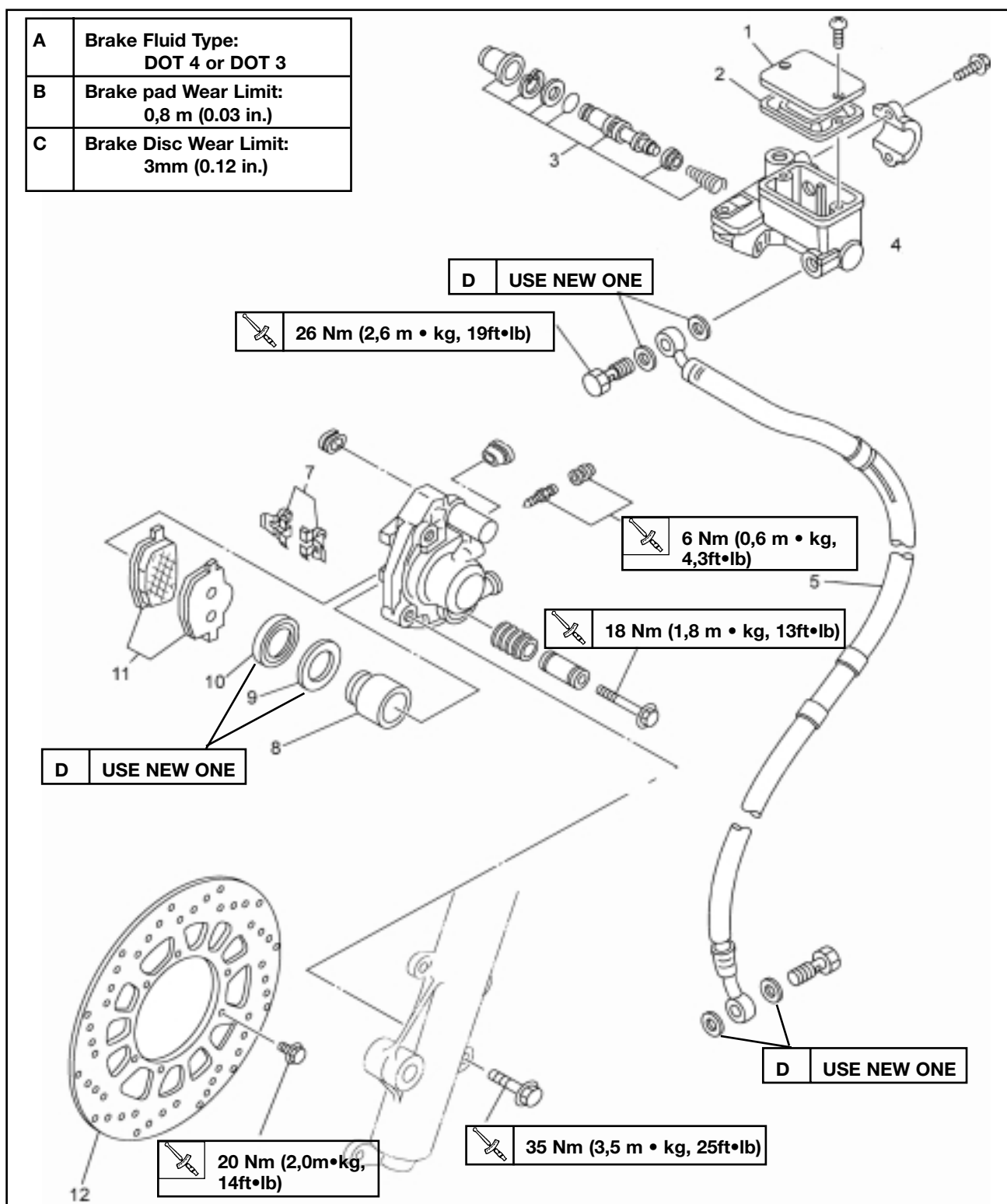

# FRONT AND REAR BRAKE

CHAS



- ① Reservoir tank cap protector
- ② Reservoir tank cap
- ③ Inner cap
- ④ Diaphragm
- ⑤ Reservoir tank
- ⑥ Reservoir hose

- ⑦ Master cylinder
- ⑧ Master cylinder kit
- ⑨ Brake hose
- ⑩ Brake caliper
- ⑪ Piston
- ⑫ Piston seal

- ⑬ Dust seal
- ⑭ Shim
- ⑮ Pad spring
- ⑯ Brake pads
- ⑰ Brake disc

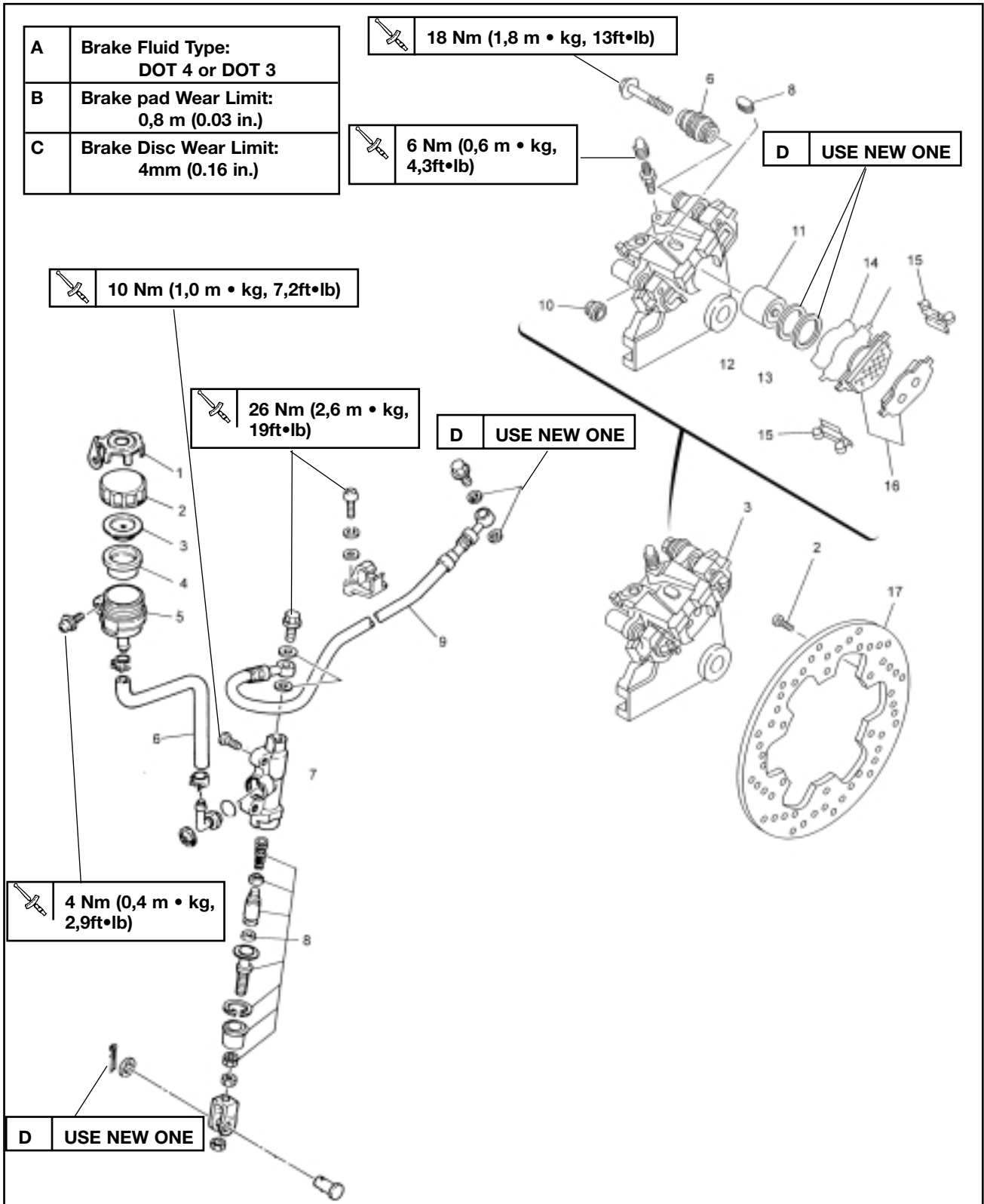





EAS00579

**CAUTION**

Disc brake components rarely require disassembly.

Therefore, always follow these preventive measures:

- Never disassemble brake components unless absolutely necessary.
- If any connection on the hydraulic brake system is disconnected, the entire brake system must be disassembled, drained, cleaned, properly filled, and bled after reassembly.
- Never use solvents on internal brake components.
- Use only clean or new brake fluid for cleaning brake components.
- Brake fluid may damage painted surfaces and plastic parts. Therefore, always clean up any spilt brake fluid immediately.
- Avoid brake fluid coming into contact with the eyes as it can cause serious injury.

**FIRST AID FOR BRAKE FLUID ENTERING THE EYES:**

- Flush with water for 15 minutes and get immediate medical attention.

EAS00581

**REPLACING THE FRONT BRAKE PADS****NOTE:**

When replacing the brake pads, it is not necessary to disconnect the brake hose or disassemble the brake caliper.

1. Loosen:
  - retaining bolt (caliper body)
2. Turn:
  - brake caliper counterclockwise

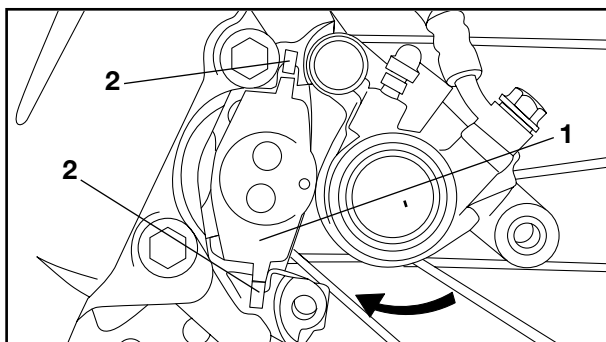



## REPLACING THE FRONT BRAKE PADS/ REPLACING THE REAR BRAKE PADS

CHAS

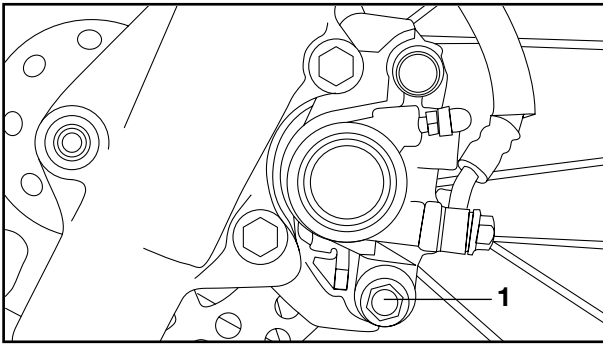

6. Lubricate:
- retaining bolt ①



**Recommended lubricant**  
Lithium-soap-based grease

### CAUTION

- Do not allow grease to contact the brake pads.
- Remove any excess grease.

7. Install:
- retaining bolt



18 Nm (1,8 m•kg, 13ft•lb)

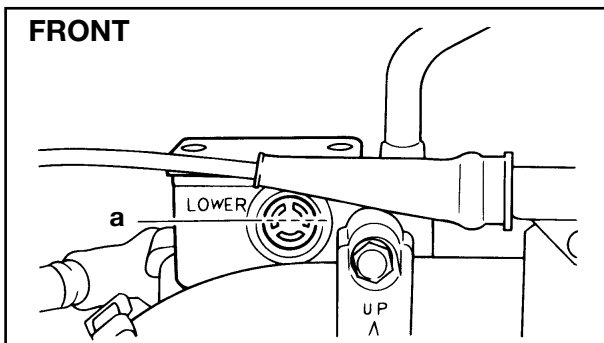

8. Check:
- brake fluid level  
Below the minimum level mark @ → Add the recommended brake fluid to the proper level.  
Refer to “CHECKING THE BRAKE FLUID LEVEL” in chapter 3.

9. Check:
- brake lever operation  
Soft or spongy feeling → Bleed the brake system.  
Refer to “BLEEDING THE HYDRAULIC BRAKE SYSTEM” in chapter 3.

EAS00583

## REPLACING THE REAR BRAKE PADS

### NOTE:

When replacing the brake pads, it is not necessary to disconnect the brake hose or disassemble the brake caliper.

## REPLACING THE REAR BRAKE PADS

CHAS

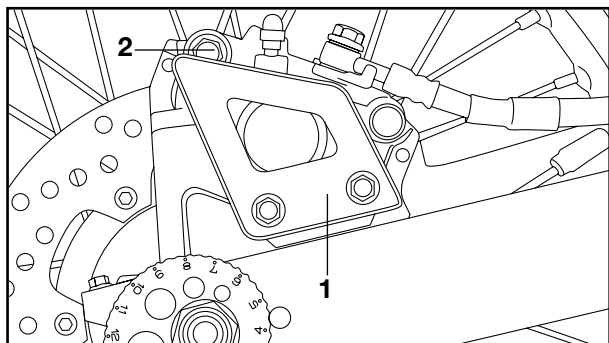

1. Remove:
  - Protector (caliper body) ①
  - Retaining bolt ②
  - Turn the caliper body counterclockwise

2. Remove:
  - brake pads ①
  - brake pad springs ②
  - Shim (brake pad)

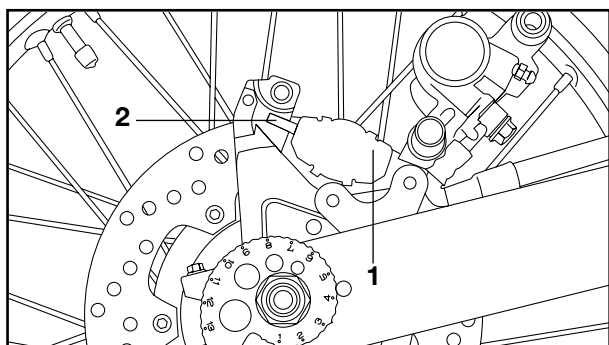

3. Measure:
  - brake pad wear limit ①Out of specification → Replace the brake pads as a set.



**Brake pad wear limit**  
**0.8 mm (0.03 in)**

4. Install:
  - brake pad shims (onto the brake pads)
  - brake pad springs
  - brake pads

**NOTE:** \_\_\_\_\_

Always install new brake pads, brake pad shims, and a brake pad spring as a set.



- a. Connect a clear plastic hose ① tightly to the bleed screw ②. Put the other end of the hose into an open container.
- b. Loosen the bleed screw and push the brake caliper pistons into the brake caliper with your finger.
- c. Tighten the bleed screw.



**Bleed screw**  
**6 Nm (0.6 m•kg, 4.3 ft•lb)**

## REPLACING THE REAR BRAKE PADS

CHAS

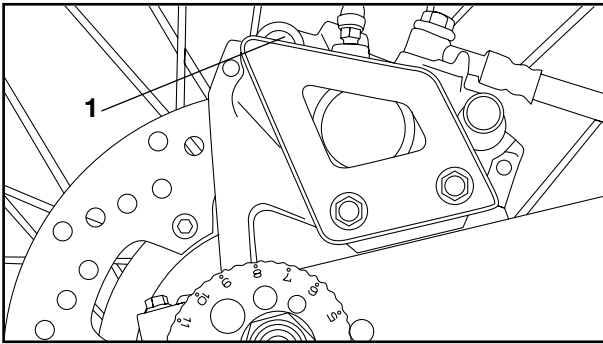

5. Lubricate:
- Retaining bolt (Caliper body) ①

6. Tighten:
- Retaining bolt (Caliper body) ①

 **18 Nm (1,8 m•kg, 13ft•lb)**

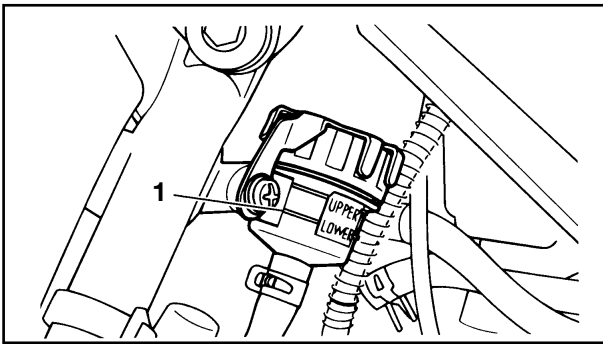

7. Check:
- brake fluid level  
Below the minimum level mark ① → Add the recommended brake fluid to the proper level.  
Refer to “CHECKING THE BRAKE FLUID LEVEL” in chapter 3.

8. Check:
- brake pedal operation  
Soft or spongy feeling → Bleed the brake system.  
Refer to “BLEEDING THE HYDRAULIC BRAKE SYSTEM” in chapter 3.

## DISASSEMBLING THE FRONT BRAKE CALIPER

CHAS

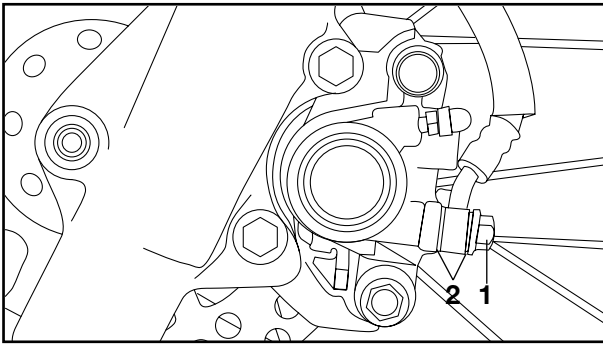

EAS00618

### DISASSEMBLING THE FRONT BRAKE CALIPER

#### NOTE:

Before disassembling the brake caliper, drain the brake fluid from the entire brake system.

#### 1. Remove:

- union bolt ①
- copper washers ②
- brake hose

#### NOTE:

Put the end of the brake hose into a container and pump out the brake fluid carefully.

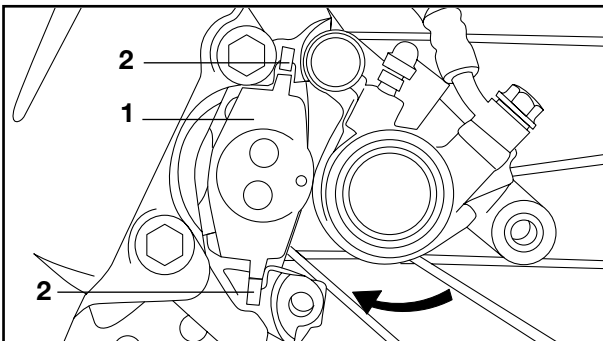

#### 2. Remove:

- Retaining bolt (caliper body)
  - Brake pads ①
  - Pad springs ②
- Refer to the "BRAKE PAD REPLACEMENT" section.

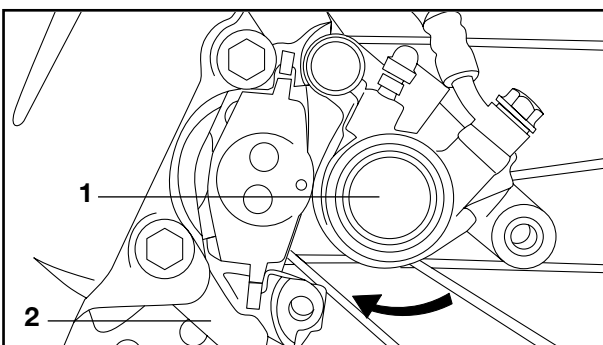

#### 3. Remove:

- Caliper body ①
- Caliper bracket ②

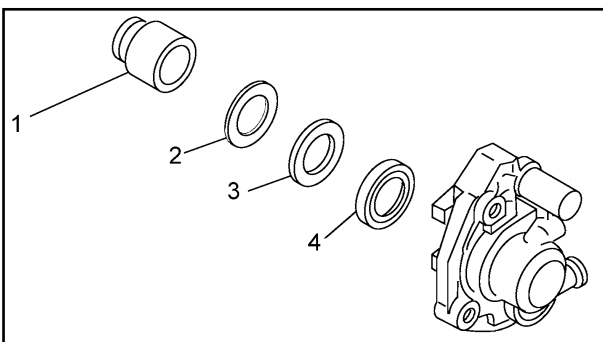

#### 4. Remove:

- Caliper piston ①
- Clip ②
- Dust seal ③
- Piston seal ④







# DISASSEMBLING THE FRONT BRAKE MASTER CYLINDER

CHAS



EAS00588

## DISASSEMBLING THE FRONT BRAKE MASTER CYLINDER

### NOTE:

Before disassembling the front brake master cylinder, drain the brake fluid from the entire brake system.

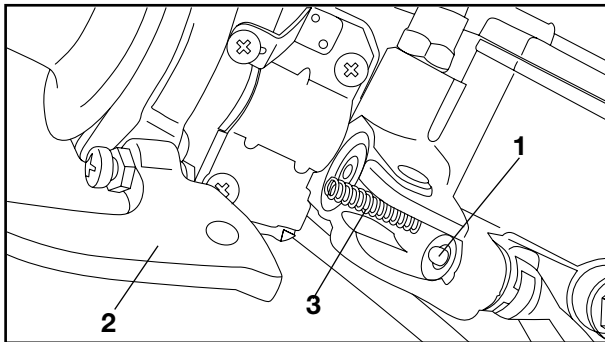

### 1. Remove:

- Brake switch ①
- Brake lever ②
- Return spring (brake lever) ③

### NOTE:

When removing the brake switch push the switch hook using a suitable rod, then pull it out.

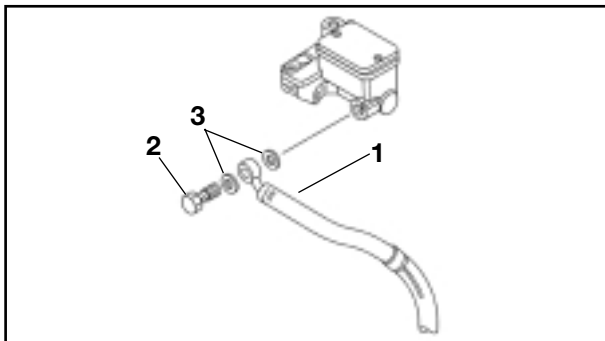

- ### 2. Pull back the brake hose cover ① from the master cylinder.

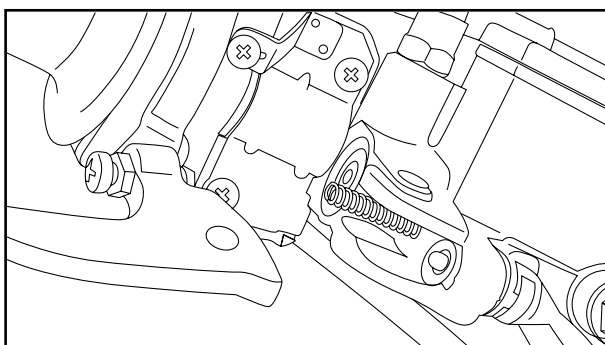

### 3. Remove:

- Union bolt ②
- Cooper washers ③

### 4. Remove:

- Bracket (master cylinder)
- Master cylinder

## DISASSEMBLING THE FRONT BRAKE MASTER CYLINDER/DISASSEMBLING THE REAR BRAKE MASTER CYLINDER

CHAS

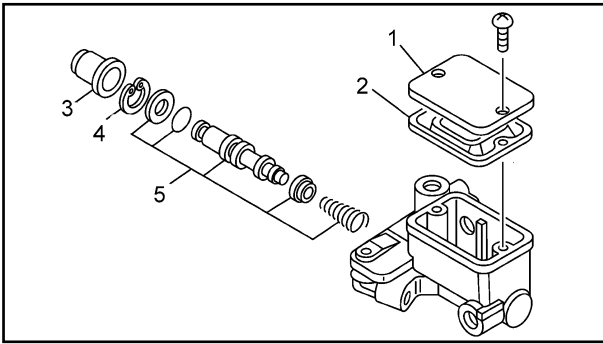

5. Remove:
- Cap (master cylinder) ①
  - Diaphragm ②
  - Dust boot ③
  - Circlip ④
  - Master cylinder kit ⑤

### NOTE:

To collect any remaining brake fluid, place a container under the master cylinder and the end of the brake hose.

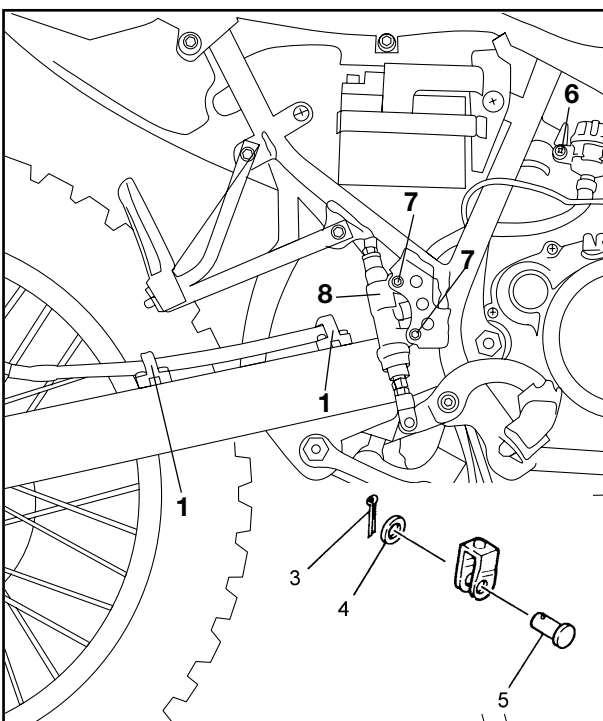

## DISASSEMBLING THE REAR BRAKE MASTER CYLINDER

1. Remove:
- Brake hose guides ①
2. Loosen:
- Union bolt ②
3. Remove:
- Cotter pin ③
  - Washer ④
  - Cotter pin ⑤
  - Screw (Reservoir tank) ⑥
  - Bolts (master cylinder) ⑦
  - Master cylinder ⑧  
(with brake hose and reservoir tank)

## DISASSEMBLING THE REAR BRAKE MASTER CYLINDER/CHECKING THE FRONT AND REAR BRAKE CALIPER

CHAS

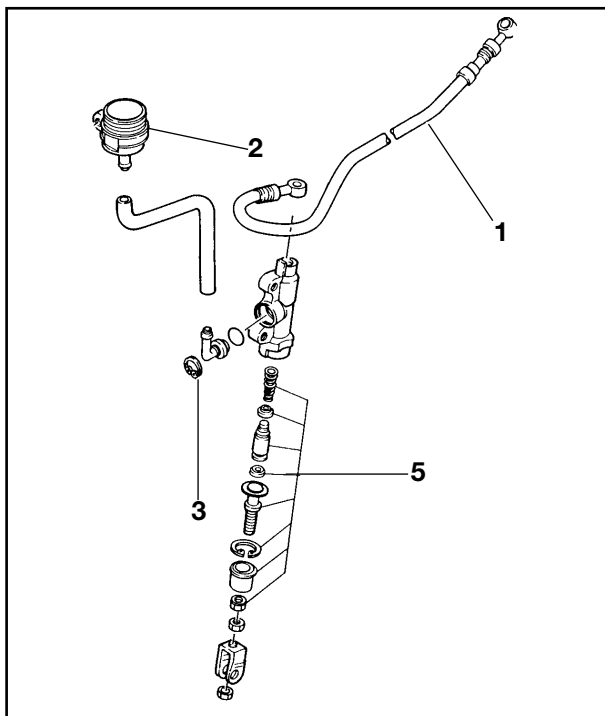

4. Remove:
- Brake hoses ①
  - Reservoir tank ②
  - Circlip ③
  - Push rod
  - Master cylinder kit ⑤

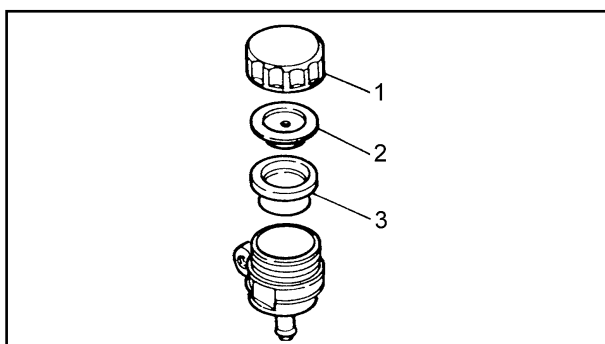

5. Remove:
- Cap (reservoir tank) ①
  - Inner cap (reservoir tank) ②
  - Diaphragm ③

**NOTE:** \_\_\_\_\_

To collect any remaining brake fluid, place a container under the master cylinder and the end of the brake hose.

\_\_\_\_\_

EAS00630

### CHECKING THE FRONT AND REAR BRAKE CALIPER

Recommended brake component replacement schedule	
Brake pads	If necessary
Piston seals	Every two years
Brake hose	Every four years
Brake fluid	Every two years and whenever the brake is disassembled

# CHECKING THE FRONT AND REAR BRAKE CALIPER

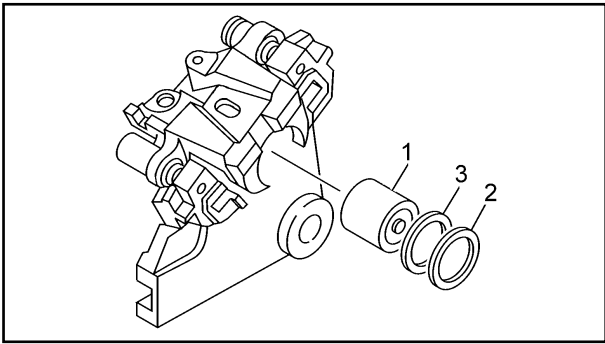

1. Check:
  - brake caliper piston ①  
Rust/scratches/wear → Replace the brake caliper piston.
  - brake caliper cylinder ②  
Scratches/wear → Replace the brake caliper assembly.
  - brake caliper body ③  
Cracks/damage → Replace the brake caliper assembly.
  - brake fluid delivery passage (brake caliper body)  
Obstruction → Blow out with compressed air.

**⚠ WARNING**

**Whenever a brake caliper is disassembled, replace the piston seals.**

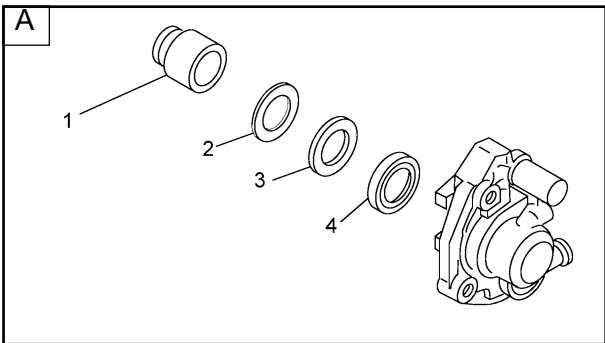

2. Check:
  - Caliper body ①
  - Caliper bracket ②  
Cracks/damage → Replace.
  - Oil delivery passage (caliper body)  
Blow out with compressed air.
  - Slide collar (caliper body) ③
  - Guide shaft (caliper bracket) ④  
Rust/wear/damage → Replace.
  - Slider boot caliper body ⑤
  - Dust boot (Guide pin - bracket)  
Cracks/damage → Replace.

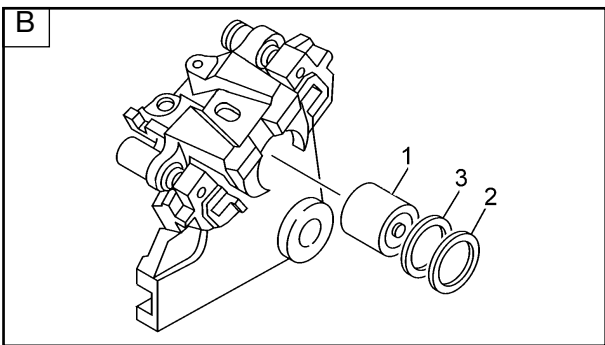

- A Front
- B Rear

# CHECKING THE FRONT AND REAR BRAKE CALIPER

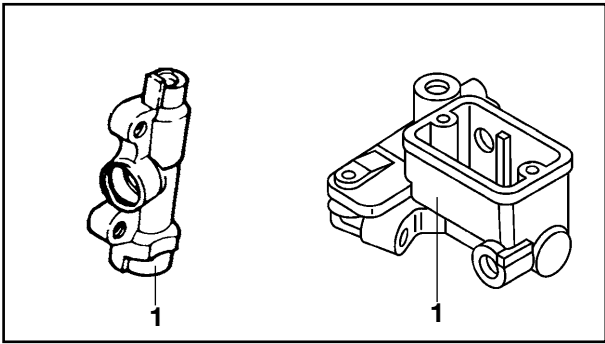
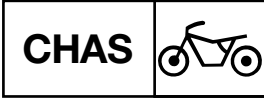

3. Check:
- Master cylinder ①  
Wear/scratches → Replace the caliper assembly.
  - Master cylinder body ②  
Cracks/damage → Replace.
  - Oil delivery passage (caliper body)  
Blow out with compressed air.
- A Front  
 B Rear

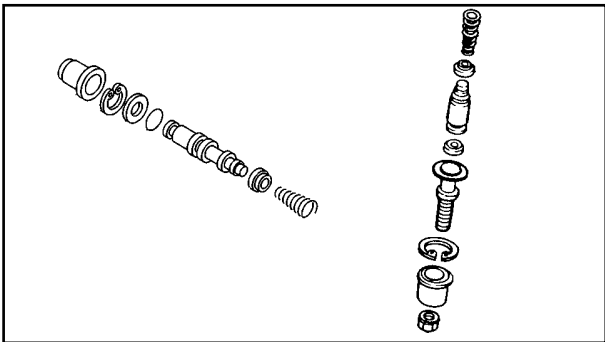

4. Check:
- Master cylinder kit ①  
Scratches/Wear/Damage → Replace.
- A Front  
 B Rear

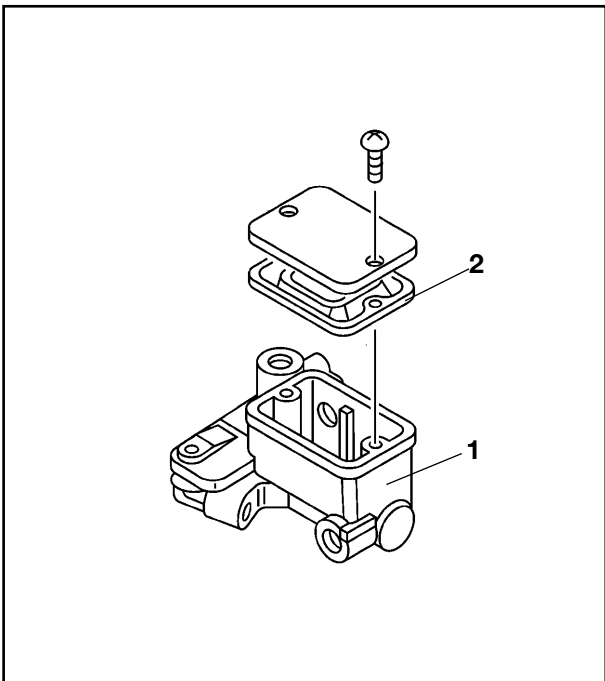

5. Check:
- Reservoir tank ①  
Cracks/damage → Replace.
  - Diaphragm (Front) ②  
Wear/damage → Replace.

6. Check:
- Brake hoses  
Cracks/wear/damage → Replace.

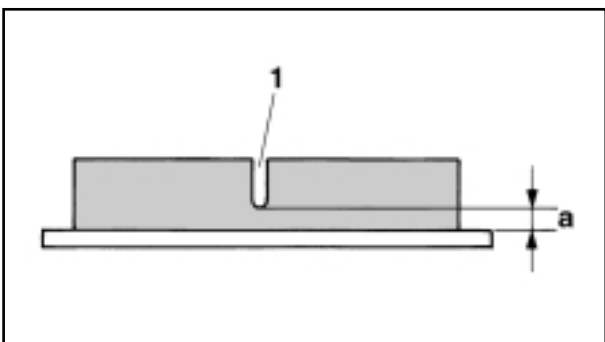

7. Measure:
- Brake pads (thickness) ②  
Out of specification → Replace.

	<b>Brake pad wear limit</b> <b>0.8 mm (0.03 in)</b>
--	--

- ① Wear indicator

# CHECKING THE FRONT AND REAR BRAKE CALIPER



**NOTE:** \_\_\_\_\_

- Replace the pad spring as a set if pad replacement is required.
- Replace the pads as a set if either if found to be worn to the wear limit.

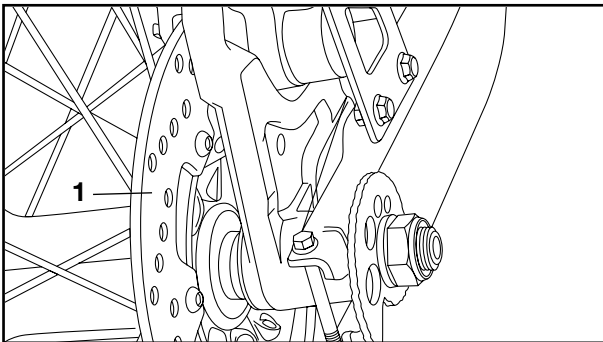

8. Inspect:
- Brake disc ①  
Galling/damage → Replace.

9. Measure:
- Brake disc deflection  
Out of specification → Inspect wheel runout.  
If wheel runout is in good condition, replace.

	<b>Maximum deflection:</b> 0.15mm (0.006in.)
--	---

- Brake disc thickness  
Out of specification → Replace.

	<b>Minimum thickness:</b> Front: 3.0mm (0.12in.) Rear: 4.0mm (0.16in.)
--	--

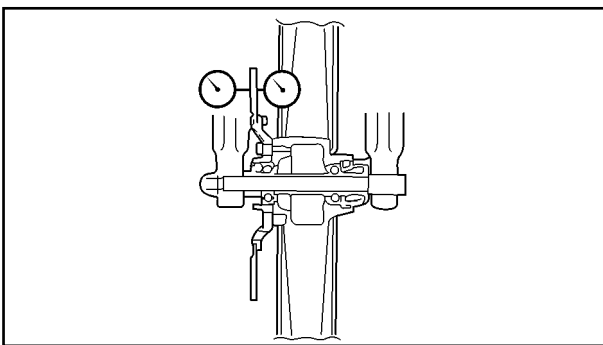

- ① Dial gauge
- A Front
- B Rear

	<b>Bolt (brake disc):</b> 20 Nm (2.0 m•kg, 14ft•lb) Use LOCTITE®
--	--

# ASSEMBLING AND INSTALLING THE FRONT AND REAR BRAKE CALIPER

CHAS



## ASSEMBLING AND INSTALLING THE FRONT AND REAR BRAKE CALIPER

### ⚠ WARNING

- Before installation, all internal brake components should be cleaned and lubricated with clean or new brake fluid.
- Never use solvents on internal brake components as they will cause the piston seals to swell and distort.
- Whenever a brake caliper is disassembled, replace the brake caliper piston seals.



Recommended brake fluid  
DOT 4

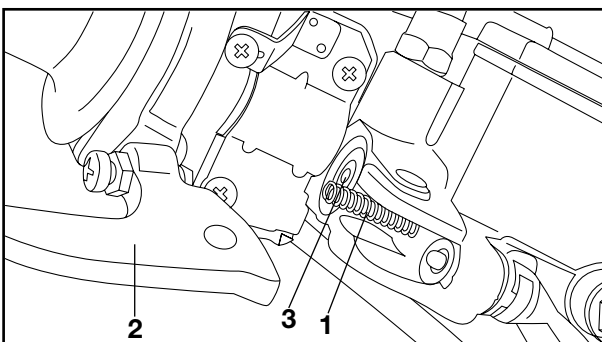
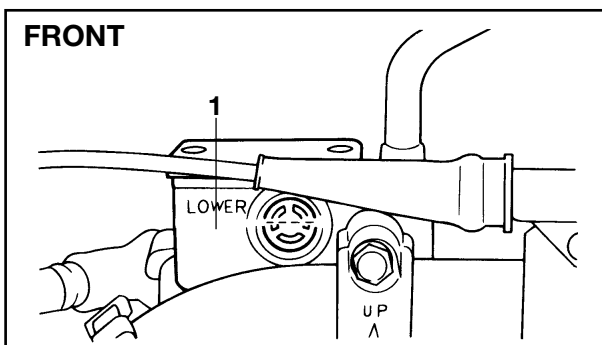
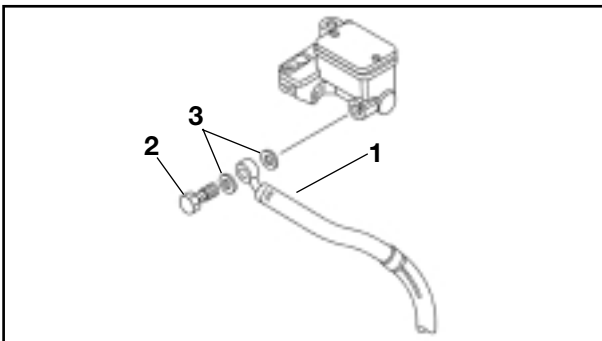

### Front brake

1. Install:
  - Master cylinder kit (1)
  - Circlip (2)
  - Dust boot (3)

2. Install:
  - Master cylinder (1)

### NOTE:

- Install the master cylinder bracket with the "UP" mark facing upward.
- Tighten first the upper bolt, then the lower bolt.



**Bolts (Master cylinder bracket):**  
9 Nm (0.9 m•kg, 6.5ft•lb)

3. Install:
  - Return spring (brake lever) (1)
  - Brake lever (2)
  - Brake switch (3)

### NOTE:

Apply lithium soap base grease to the brake lever pivot.

# ASSEMBLING AND INSTALLING THE FRONT AND REAR BRAKE CALIPER

CHAS

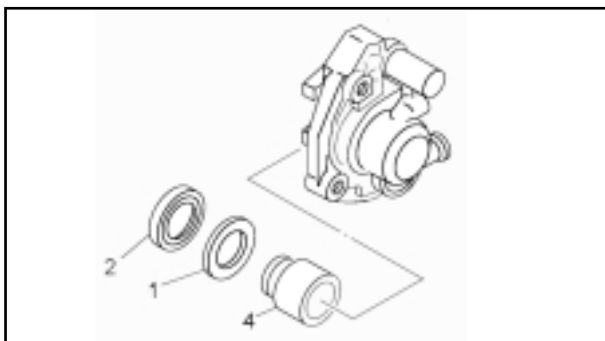

4. Install:
- Piston seal ①
  - Dust seal ②
  - Clip ③
  - Caliper piston ④

### ⚠ WARNING

Always use new piston seal and dust seal.

### CAUTION

Install the clip into the slot on the caliper body correctly.

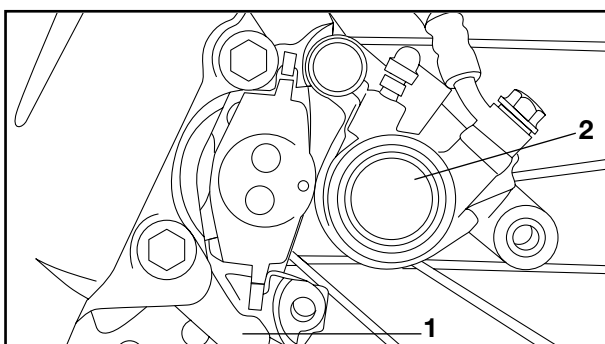

5. Install:
- Caliper bracket ①



**Caliper bracket:**  
35 Nm (3.5 m•kg, 25ft•lb)

6. Install:
- Pad springs
  - Brake pads
- Refer to the "BRAKE PAD REPLACEMENT" section.
7. Install:
- Caliper body ②

### NOTE:

Apply the lithium soap-base grease onto the caliper guide shaft and retaining bolt.

### CAUTION

- Take care no to allow the brake pads to be smeared by grease.
- Wipe off any unnecessary grease that comes out of place.



**Retaining bolt (Caliper body):**  
18 Nm (1.8m•kg, 13ft•lb)



## ASSEMBLING AND INSTALLING THE FRONT AND REAR BRAKE CALIPER

CHAS

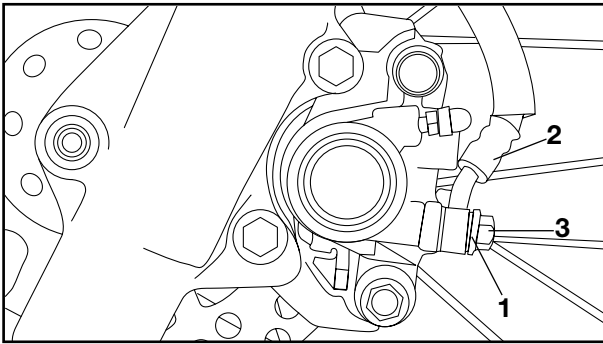

8. Install:
- Copper washers ①
  - Brake hose ②
  - Union bolt ③



Union bolt:  
26 Nm (2.6m•kg, 19ft•lb)

### CAUTION

When installing the brake hoses to the caliper ① and master cylinder ② lightly touch the brake pipe with the projections ③ on them.

### WARNING

- Proper hose routing is essential to insure safe machine operation. Refer to “CABLE ROUTING”
- Always use new copper washers.

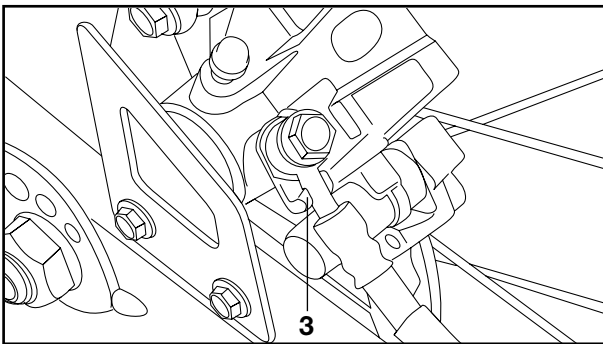

9. Fill:
- Master cylinder tank



Recommended brake fluid:  
DOT 4

### CAUTION

Brake fluid may damage painted surfaces and plastic parts. Therefore, always clean up any spilt brake fluid immediately.

### WARNING

- Use only the designated brake fluid. Other brake fluids may cause the rubber seals to deteriorate, causing leakage and poor brake performance.
- Refill with the same type of brake fluid that is already in the system. Mixing brake fluids may result in a harmful chemical reaction, leading to poor brake performance.
- When refilling, be careful that water does not enter the brake master cylinder reservoir. Water will significantly lower the boiling point of the brake fluid and could cause vapor lock.

# ASSEMBLING AND INSTALLING THE FRONT AND REAR BRAKE CALIPER

CHAS



10. Bleed:
  - brake system
  - Refer to "AIR BLEEDING" section.
11. Check:
  - brake fluid level
  - Below the minimum level mark (a) → Add the recommended brake fluid to the proper level.
  - Refer to "BRAKE FLUID INSPECTION" in chapter 3.
  - ① "Lower" level line.

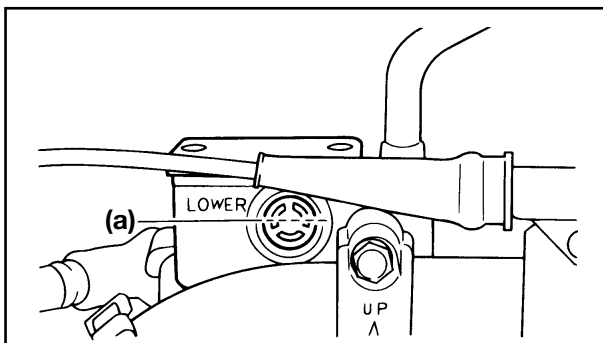

12. Install:
  - Diaphragm ①
  - Cap (Master cylinder) ②

	<b>Screw (Master cylinder):</b> 2 Nm (0.2m•kg, 1.4ft•lb)
--	---

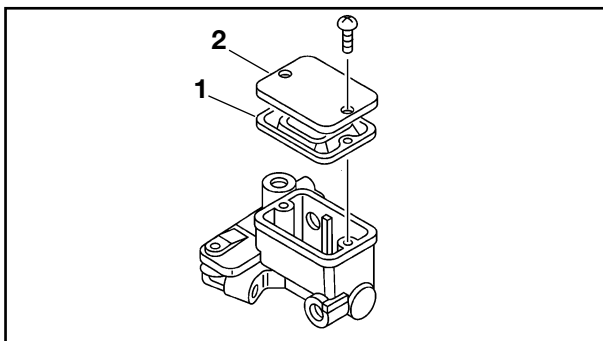

13. Adjust:
  - Front brake lever free play ③

	<b>Free play:</b> 2~5mm (0.08~0.20in)
--	--

Refer to the "FRONT BRAKE ADJUSTMENT" section in chapter 3.

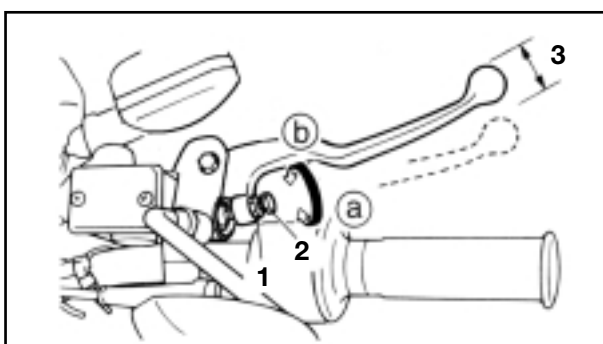

# ASSEMBLING AND INSTALLING THE FRONT AND REAR BRAKE CALIPER

CHAS

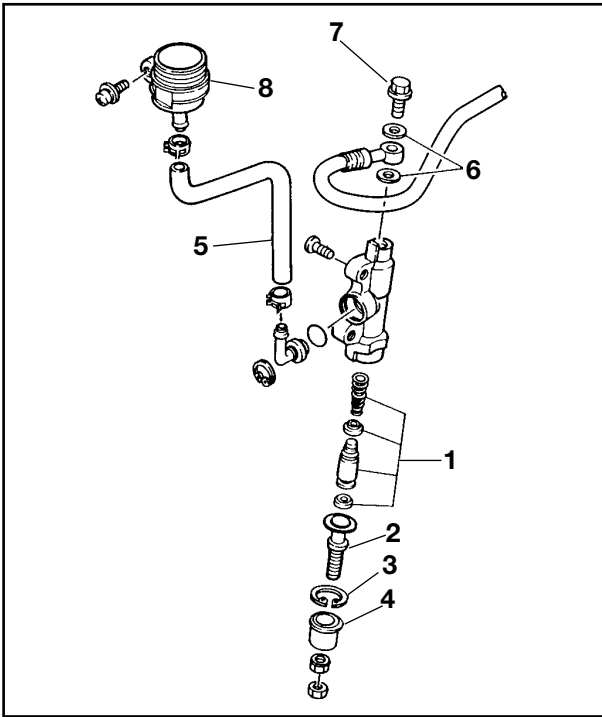

## ASSEMBLING AND INSTALLING THE FRONT AND REAR BRAKE CALIPER

1. Install:

- Master cylinder kit ①
- Push rod ②
- Circlip ③
- Dust boot ④
- Brake hoses ⑤
- Cooper washers ⑥
- Union bolt ⑦
- Reservoir tank ⑧

**NOTE:** \_\_\_\_\_

At this time, temporarily tighten the union bolt

**⚠ WARNING** \_\_\_\_\_

Always use a new cooper washer

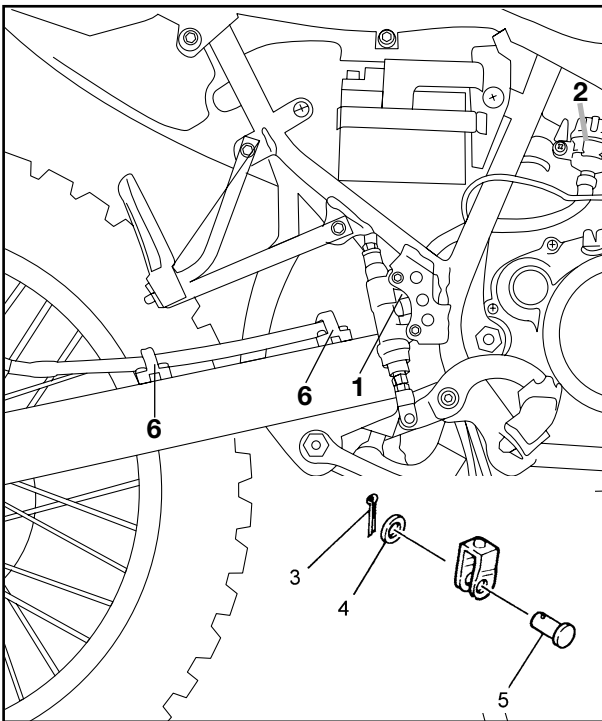

2. Install:

- Master cylinder ①
- Reservoir tank ②
- Pin ③
- Washer ④
- Cotter pin ⑤
- Brake hose guides ⑥

**NOTE:** \_\_\_\_\_

Apply the lithium-soap base grease to the pin.

**⚠ WARNING** \_\_\_\_\_

Always use a new cotter pin.

	<p><b>Bolt (Master cylinder):</b> 10 Nm (1.0 m•kg, 7.2 ft•lb)</p> <p><b>Screw (Reservoir tank):</b> 4 Nm (0.4 m•kg, 2.9 ft•lb)</p>
--	--

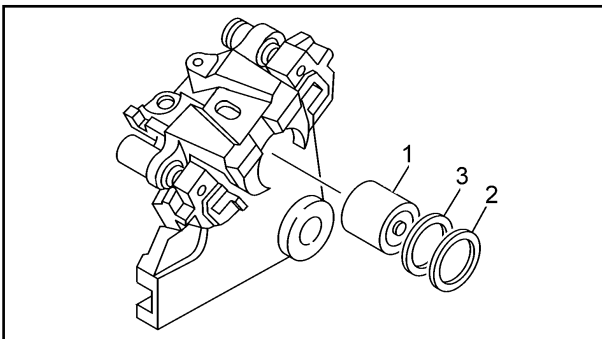

3. Install:

- Piston seal ③
- Dust seal ②
- Caliper piston ①

**⚠ WARNING** \_\_\_\_\_

Always use new piston seal and dust seal

## ASSEMBLING AND INSTALLING THE FRONT AND REAR BRAKE CALIPER

CHAS

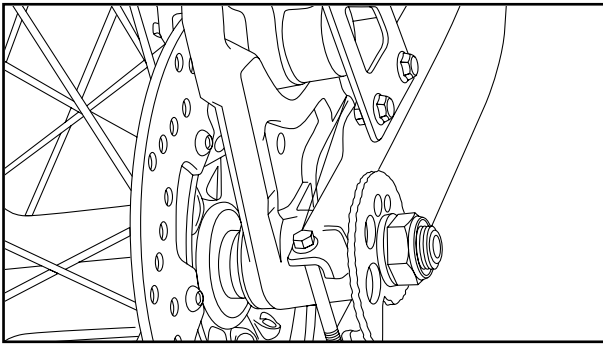

### NOTE:

When installing the caliper piston, be sure to have its open end facing the caliper cylinder

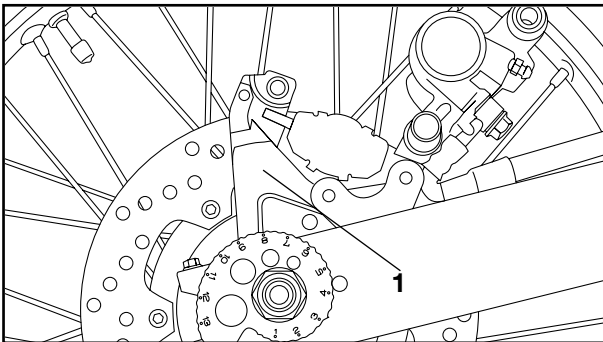

### 4. Install:

- Caliper bracket ①
- Rear wheel

Refer to the "REAR WHEEL INSTALLATION" section.

### NOTE:

Be sure the boss on the swingarm correctly engages with the locating slot on the caliper bracket.

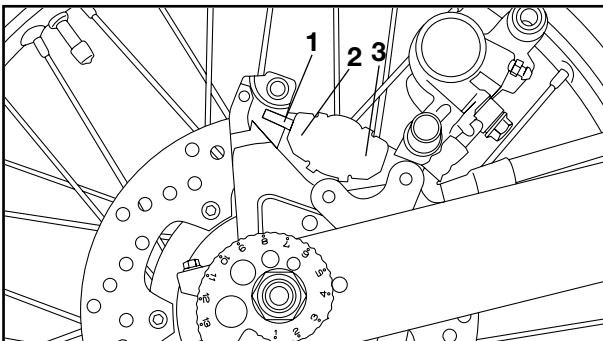

### 5. Install:

- Pad springs ①
- Brake pads ②
- Shim ③

Refer to the "BRAKE PAD REPLACEMENT" section.

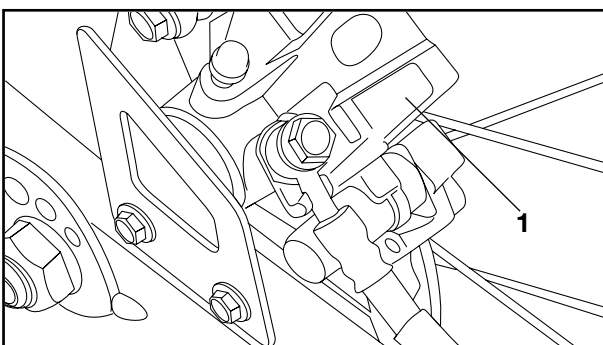

### 6. Install:

- Caliper body ①



**Retaining Bolt (Caliper body):**  
18 Nm (1.8 m•kg, 13 ft•lb)

### NOTE:

Apply the lithium-soap base grease onto the caliper guide shaft and retaining bolt

### CAUTION

- Take care not to allow the brake pads to be smeared by grease.
- Wipe off any unnecessary grease that comes out of place.

## ASSEMBLING AND INSTALLING THE FRONT AND REAR BRAKE CALIPER

CHAS



7. Install:
- Cooper washers ①
  - Brake hose ②
  - Union bolt ③
  - Protector (Caliper body) ④



**Union Bolt:**  
26 Nm (2.6 m•kg, 19 ft•lb)

### CAUTION

When installing the brake hoses to the caliper ⑤ and master cylinder ⑥, lightly touch the brake pipe with the projections ⑦ on them.

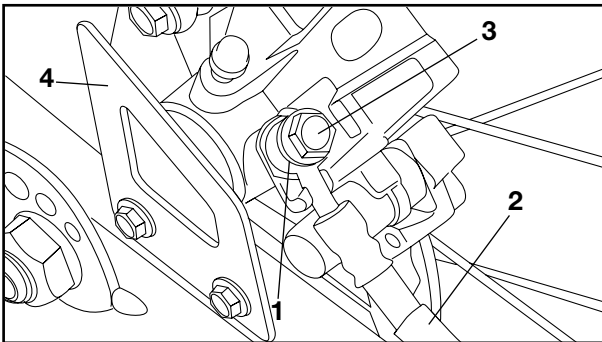

### ⚠ WARNING

- Proper hose routing is essential to insure safe machine operation. Refer to “CABLE ROUTING” section.
- Always use new cooper washers.



**Recommended brake fluid:**  
DOT 4  
If DOT 4 is not available DOT 3 can be used.

### CAUTION

Brake fluid may damage painted surfaces and plastic parts. Therefore, always clean up any spilt brake fluid immediately.

### ⚠ WARNING

- Use only the designated brake fluid. Other brake fluids may cause the rubber seals to deteriorate, causing leakage and poor brake performance.
- Refill with the same type of brake fluid that is already in the system. Mixing brake fluids may result in a harmful chemical reaction, leading to poor brake performance.
- When refilling, be careful that water does not enter the brake master cylinder reservoir. Water will significantly lower the boiling point of the brake fluid and could cause vapor lock.

# ASSEMBLING AND INSTALLING THE FRONT AND REAR BRAKE CALIPER

CHAS



9. Bleed:
- brake system
- Refer to “AIR BLEEDING” section.

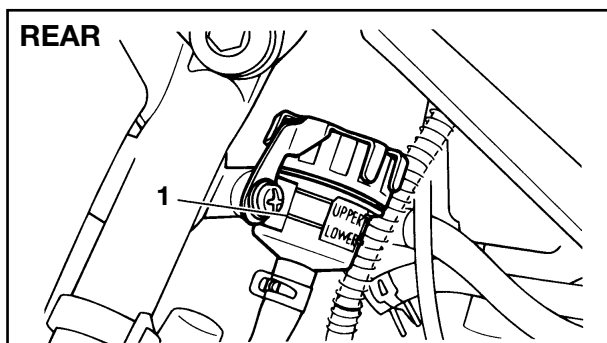

10. Check:
- brake fluid level
- Below the minimum level mark ① → Add the recommended brake fluid to the proper level.
- Refer to “BRAKE FLUID INSPECTION” in chapter 3.

① “Lower” level line.

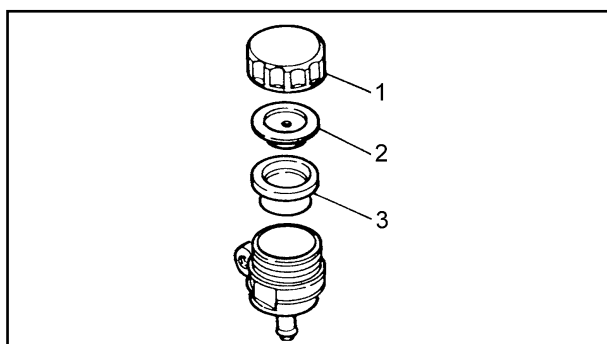

11. Install:
- Diaphragm ③
  - Inner cap (Reservoir tank) ②
  - Cap (Master cylinder) ①

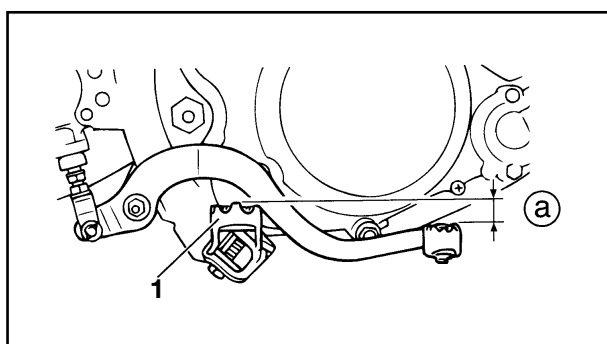

12. Adjust:
- Rear brake pedal height (a)



**Pedal height:**  
15mm (0.95in)  
Below top of footrest.

Refer to the “REAR BRAKE ADJUSTMENT” section.

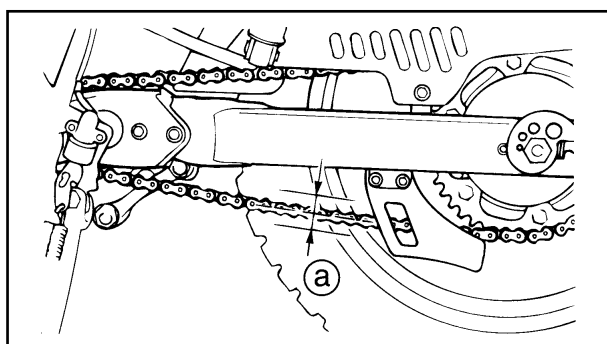

13. Adjust:
- Drive chain slack (a)
- Refer to the “DRIVE CHAIN SLACK ADJUSTMENT” section in chapter 3.



**Drive chain slack:**  
DT125RE 40~55mm (1,77~2,16in.)  
DT125X 25~40mm (0,98~1,58 in.)



# BLEEDING THE HYDRAULIC BRAKE SYSTEM



**NOTE:** \_\_\_\_\_

Loosening the bleed screw will release the pressure and cause the brake lever to contact the throttle grip or the brake pedal to fully extend.

- h. Tighten the bleed screw and then release the brake lever or brake pedal.
- i. Repeat steps (e) to (h) until all of the air bubbles have disappeared from the brake fluid in the plastic hose.
- j. Tighten the bleed screw to specification.

	<b>Bleed screw</b> <b>6 Nm (0.6 m•kg, 4.3 ft•lb)</b>
---	---

- k. Fill the brake fluid reservoir to the proper level with the recommended brake fluid. Refer to “CHECKING THE BRAKE FLUID LEVEL”.

**⚠ WARNING** \_\_\_\_\_

**After bleeding the hydraulic brake system, check the brake operation.**







## FRONT FORKS

- ① Cap bolt
- ② O-ring
- ③ Spacer
- ④ Spring seat
- ⑤ Fork spring
- ⑥ Inner fork tube
- ⑦ Damper rod
- ⑧ Oil lock pieces
- ⑨ Circlip
- ⑩ Dust seal
- ⑪ Oil seal
- ⑫ Washer
- ⑬ Slide bush
- ⑭ Outer fork tube
- ⑮ Axle holder
- ⑯ Fork boot

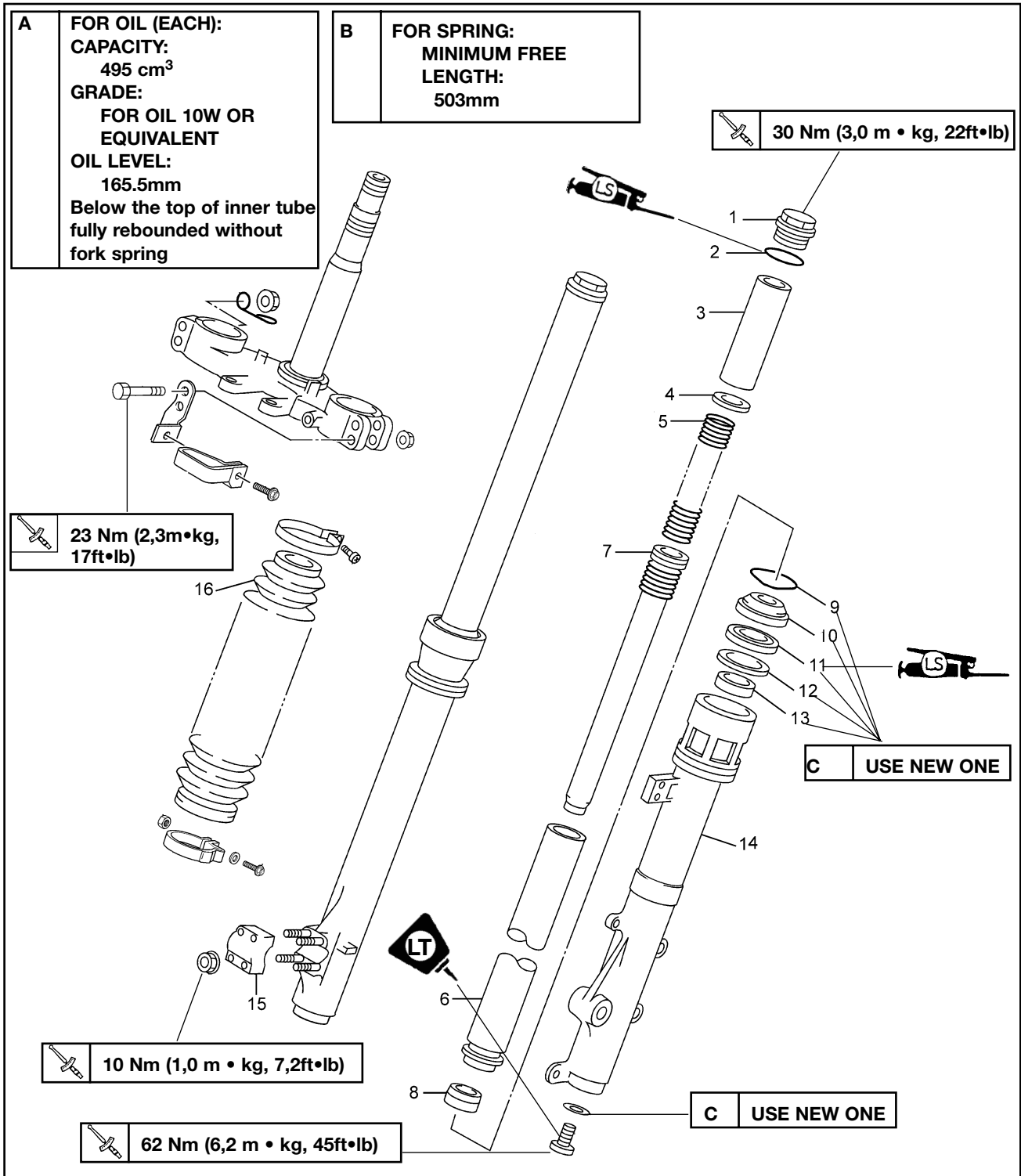



## REMOVAL

### **⚠ WARNING**

Support the motorcycle securely so there is no danger of it falling over.

- 1 Elevate the front wheel by placing a suitable stand under the engine.
2. Remove:
  - Brake caliper assembly ①
3. Loosen:
  - upper bracket pinch bolt ①
  - cap bolt ②
  - lower bracket pinch bolt ③

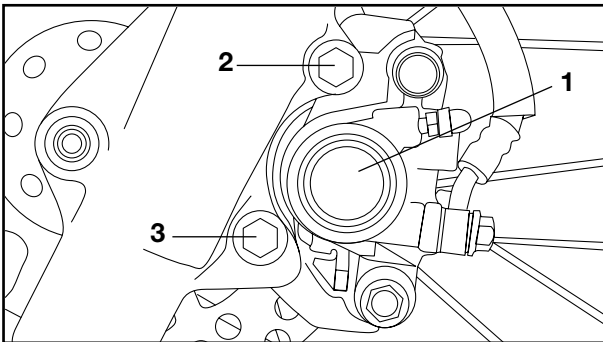

### **⚠ WARNING**

Before loosening the upper and lower bracket pinch bolts, support the front fork leg.

4. Remove:
  - front fork leg

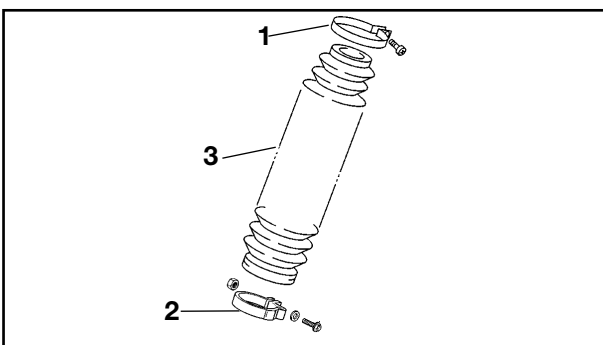

## DISASSEMBLY

1. Remove:
  - Clamps (Upper ① and lower ②)
  - Fork boot ③

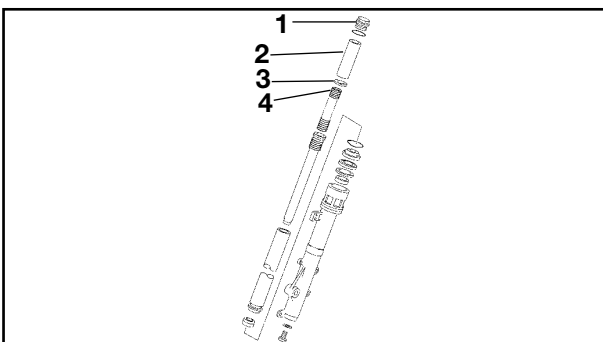

2. Remove:
  - Cap bolt ①
  - Spacer ②
  - Spring seat ③
  - Fork spring ④

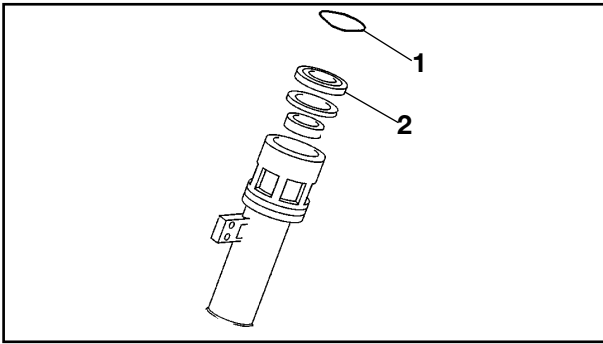

3. Drain:
- Fork oil

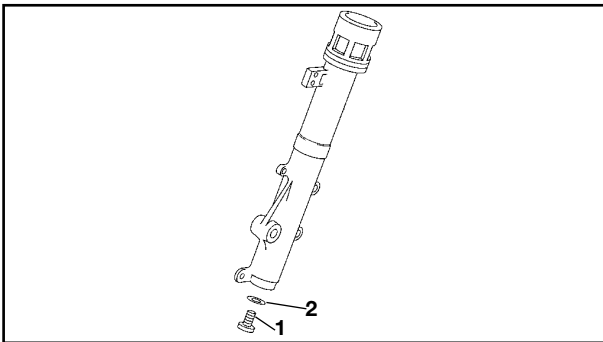

4. Remove:
- Retaining clip ①  
Use a thin slotted head screwdriver
  - Washer ②

**CAUTION**

Take care not to scratch the inner tube

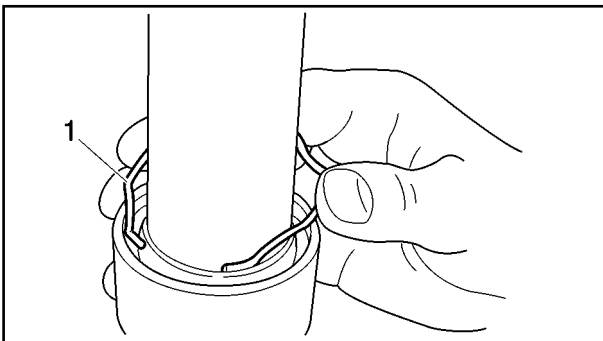

5. Remove:
- Bolt (Damper rod) ①
  - Cooper washer ②

**NOTE:**

Hold the damper rod to loosen the bolt (Damper rod) by the T-handle ① and the Holder ②

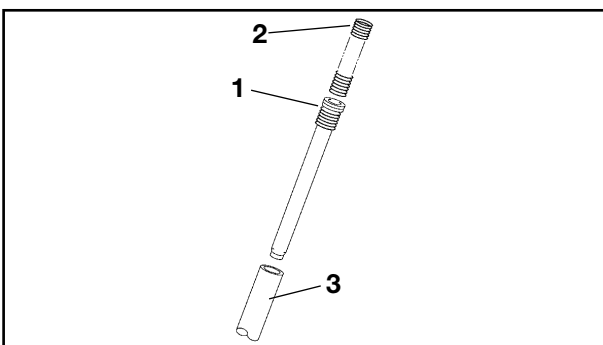

	<b>Damper rod holder</b>
	90890-01388
	<b>T-handle</b>
	90890-01326

6. Remove:
- Damper rod ①
  - Rebound spring ②  
(Out of inner fork tube ③)



## CHECKING THE FRONT FORK LEGS/ASSEMBLING THE FRONT FORK LEGS

CHAS

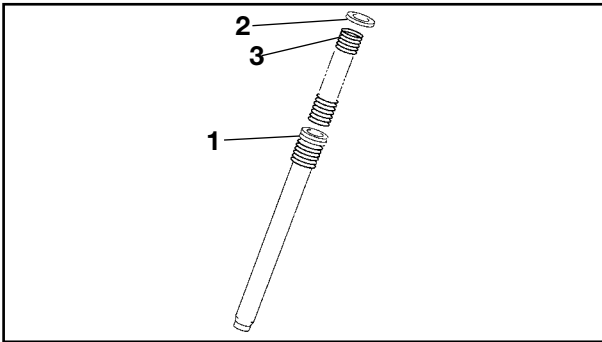

3. Check:
  - damper rod ①
  - piston ring ②  
Damage/wear → Replace.  
Obstruction → Blow out all of the oil passages with compressed air.
  - rebound spring ③  
Damage → Replace.

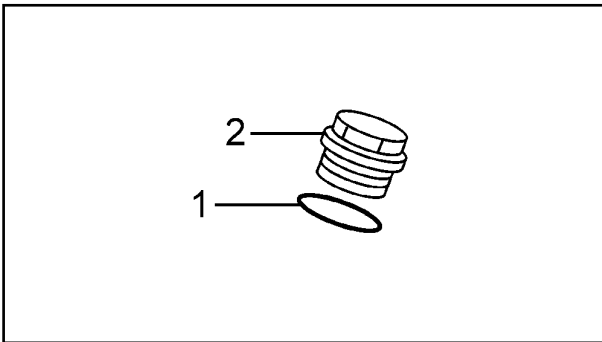

4. Check:
  - cap bolt O-ring  
Damage/wear → Replace.

EAS00659

### ASSEMBLING THE FRONT FORK LEGS

The following procedure applies to both of the front fork legs.

#### **⚠ WARNING**

- **Make sure the oil levels in both front fork legs are equal.**
- **Uneven oil levels can result in poor handling and a loss of stability.**

#### **NOTE:**

- When assembling the front fork leg, be sure to replace the following parts:
  - inner tube bushing
  - outer tube bushing
  - oil seal
  - dust seal
- Before assembling the front fork leg, make sure all of the components are clean.

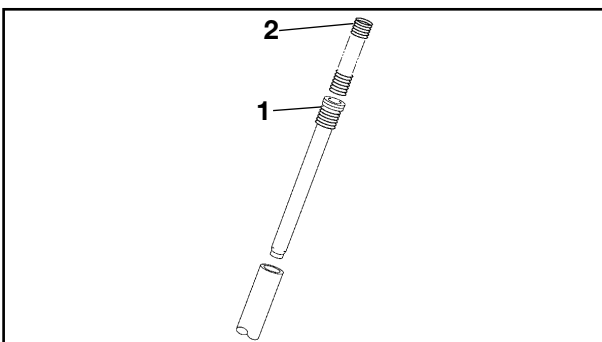

1. Install:
  - damper rod assembly ①

#### **CAUTION**

**Allow the damper rod assembly to slide slowly down the inner tube ② until it protrudes from the bottom of the inner tube. Be careful not to damage the inner tube.**

## ASSEMBLING THE FRONT FORK LEGS

CHAS



- Lubricate:
  - inner tube's outer surface



**Recommended lubricant**  
Fork oil 10W or equivalent

- Tighten:
  - damper rod assembly bolt



**62 Nm (6.2 m•kg, 45 ft•lb)**  
**LOCTITE®**

### NOTE:

While holding the damper rod assembly with the damper rod holder and T-handle, tighten the damper rod assembly bolt.



**Damper rod holder**  
90890-01388  
**T-handle**  
90890-01326

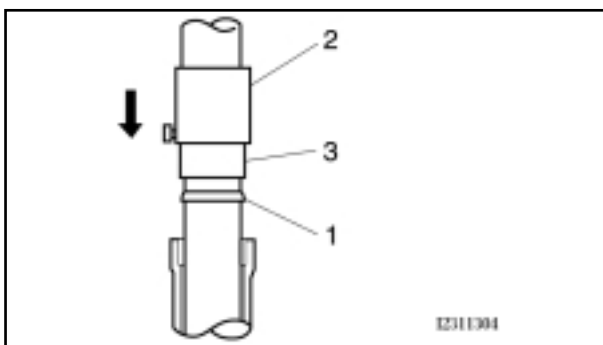

- Install:
  - outer tube bushing ①  
(with the fork seal driver weight and fork seal driver attachment)



**Fork seal driver weight**  
90890-01367  
**Fork seal driver attachment**  
90890-01381

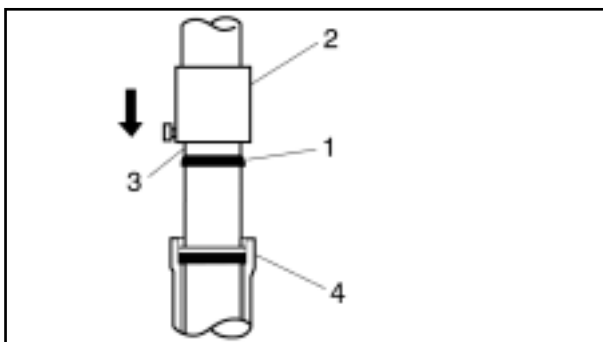

- Install:
  - washer
  - oil seal ①  
(with the fork seal driver weight and fork seal driver attachment)

### CAUTION

**Make sure the numbered side of the oil seal faces up.**

## ASSEMBLING THE FRONT FORK LEGS

CHAS

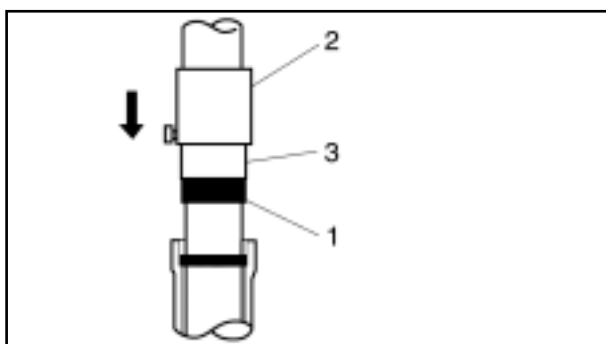

### NOTE:

- Before installing the oil seal, lubricate its lips with lithium-soap-based grease.
- Lubricate the outer surface of the inner tube with fork oil.
- Before installing the oil seal, cover the top of the front fork leg with a plastic bag 2 to protect the oil seal during installation.

### 6. Install:

- oil seal clip

### NOTE:

Adjust the oil seal clip so that it fits into the outer tube's groove.

### 7. Install:

- dust seal ①  
(with the fork seal driver weight)



**Fork seal driver weight**  
90890-01367

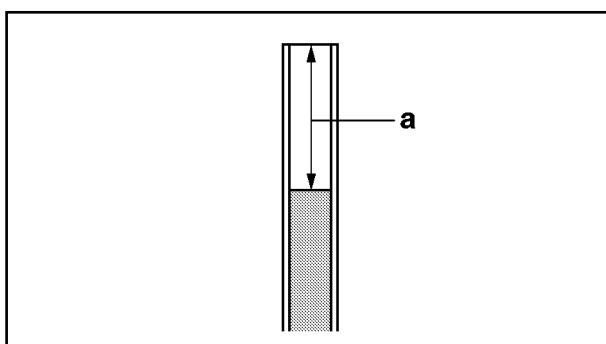

### 8. Fill:

- front fork leg  
(with the specified amount of the recommended fork oil)



**Quantity (each front fork leg)**  
DT125RE 0.495 L  
DT125X 0.6 L  
**Recommended oil**  
Yamaha fork and shock oil 10W  
or equivalent



**Front fork leg oil level (from the top of the inner tube, with the inner tube fully compressed and without the fork spring)**  
DT125RE 165.5 mm (6.52 in)  
DT125X 140mm (5.52 in)

**NOTE:**

- While filling the front fork leg, keep it upright.
- After filling, slowly pump the front fork leg up and down to distribute the fork oil.

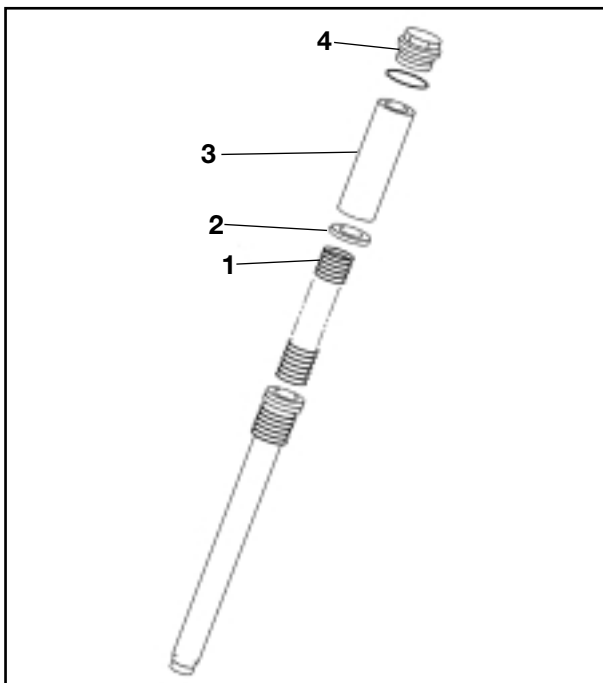
**9. Install:**

- spring ①
- spring seat ②
- spacer ③
- cap bolt ④

**NOTE:**

- Install the spring with the smaller pitch facing up.
- Before installing the cap bolt, lubricate its O-ring with grease.
- Temporarily tighten the cap bolt.





## STERING HEAD AND HADLEBARS

- ① Handlebar
- ② Handlebar grip (Right)
- ③ Handlebar grip (Left)
- ④ Handlebar holder (Upper)
- ⑤ Handlebar crown
- ⑨ Ring nut
- ⑩ Cover
- ⑪ Bearing race
- ⑫ Headlight stay

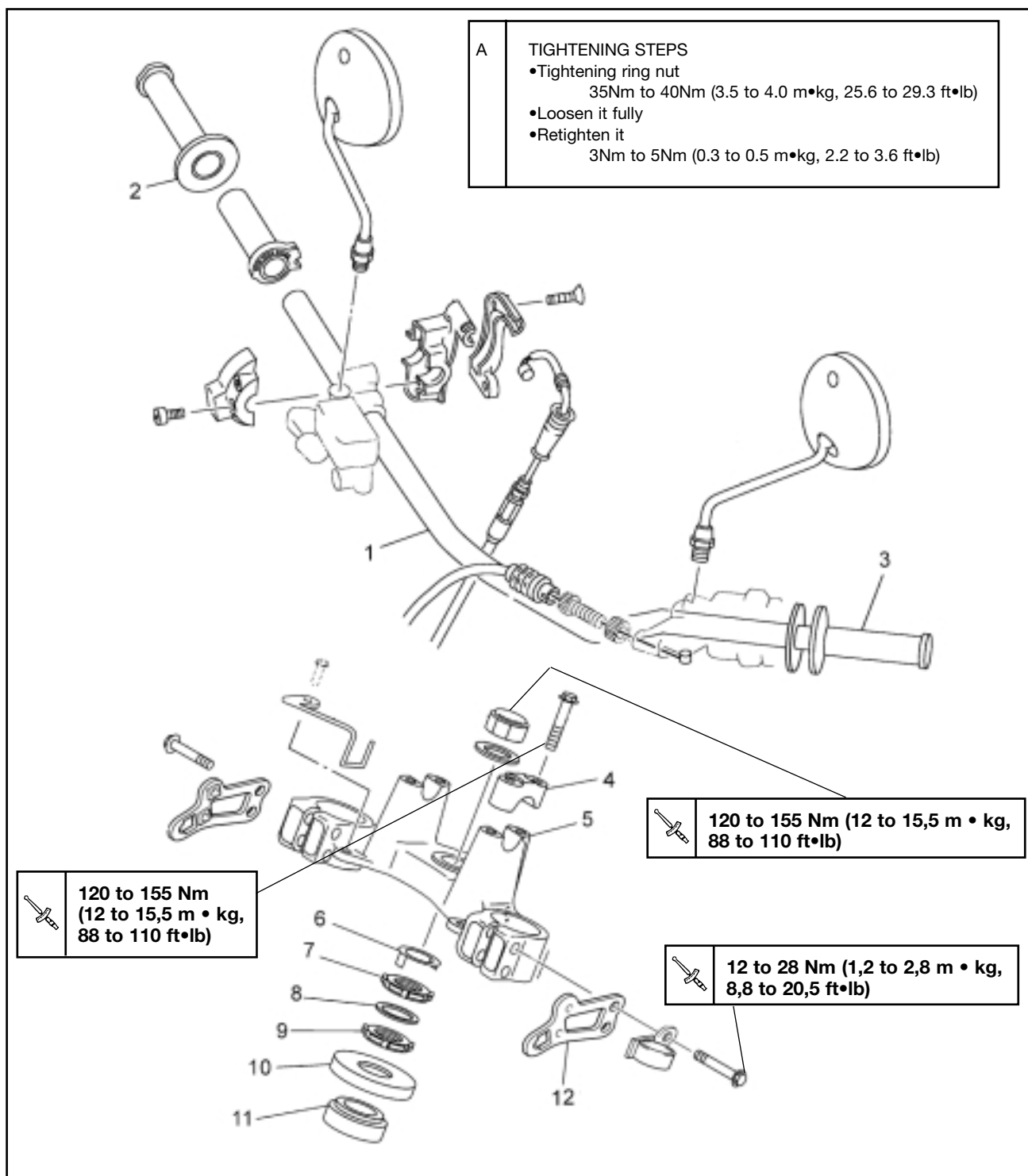

**REMOVAL**

1. Elevate the front wheel by placing a suitable stand under the engine.

**⚠ WARNING**

**Securely support the motorcycle so there is no danger of falling over**

2. Remove:
  - Front wheel  
Refer to the "FRONT WHEEL REMOVAL" section.
  - Front fork  
Refer to the "FRONT FORK REMOVAL" section.

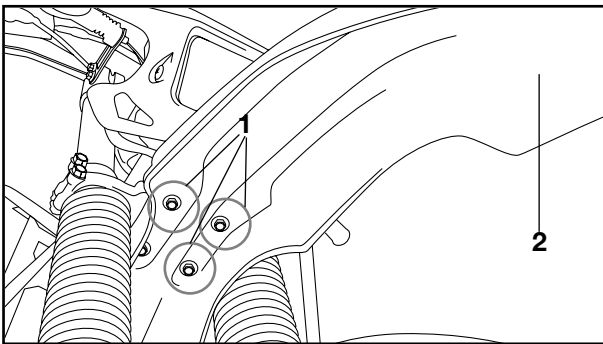

3. Remove:
  - Bolts ① (front fender)
  - Front fender ②
  - Washers

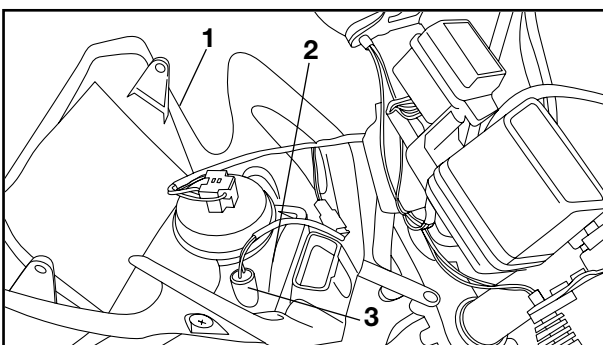

4. Remove:
  - Headlight cover ①
  - Headlight lens unit ②

5. Disconnect:
  - Headlight lead
  - Auxiliary light lead ③
6. Disconnect:
  - Flasher light leads

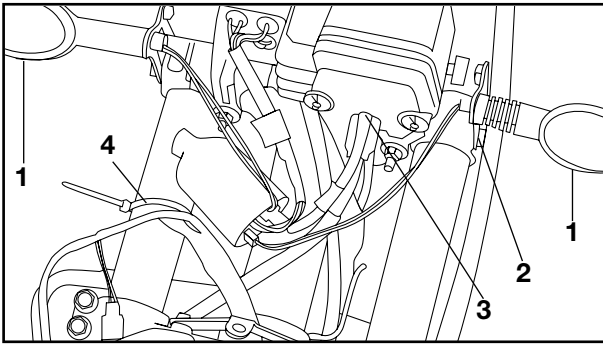

7. Remove:
  - Flasher lights (left and right) ①
  - Brake hose guide ②  
(From left side only)
8. Disconnect:
  - Speedometer cable ③

9. Remove:
  - Bands ④
10. Disconnect:
  - Meter leads
  - Handlebar switch leads
  - Main switch leads
  - Flasher relay leads

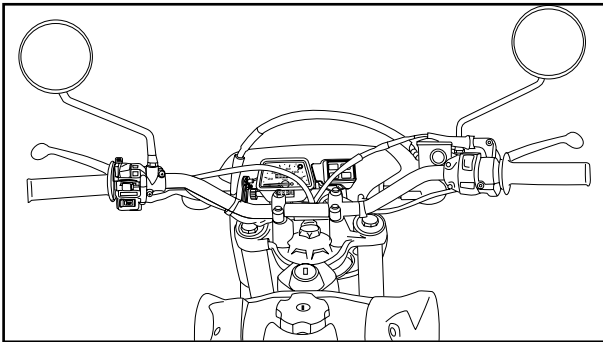

11. Remove:
  - Bands
  - Master cylinder assembly

12. Remove:
  - Brush guard

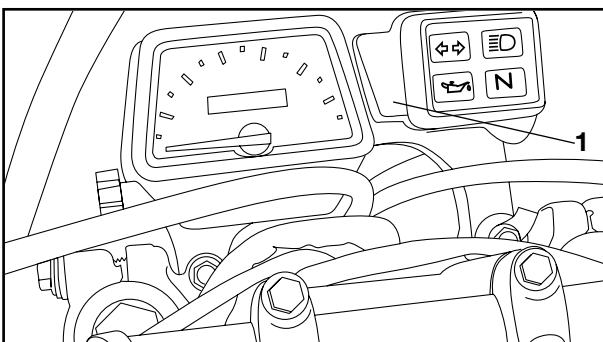

13. Disconnect:
  - Clutch cable  
(from clutch cable pivot)
14. Remove:
  - Meter assembly ①

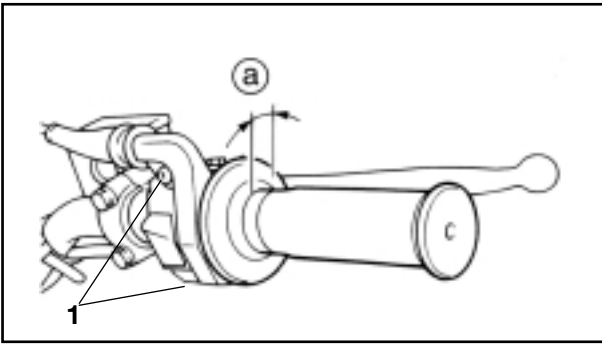

15. Loosen:
- Screws (throttle cable housing) ①

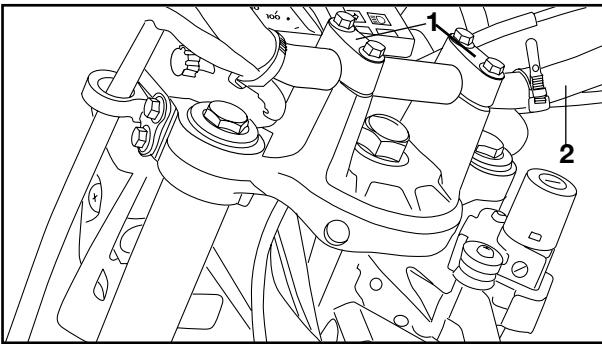

16. Remove:
- Handlebar holders ①
  - Handlebars ②

**NOTE:** \_\_\_\_\_

For completely removal of the handlebar, be sure to clear the throttle cable housing

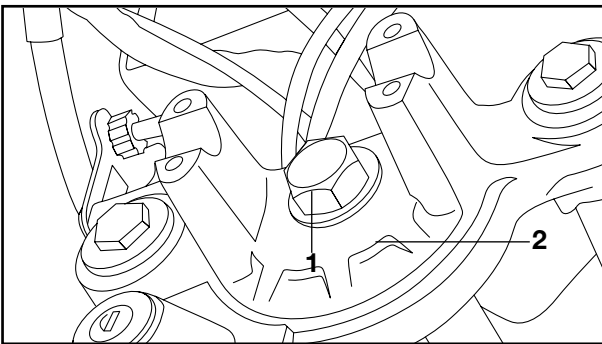

17. Remove:
- Flange nut ①
  - Handlebar crown ②

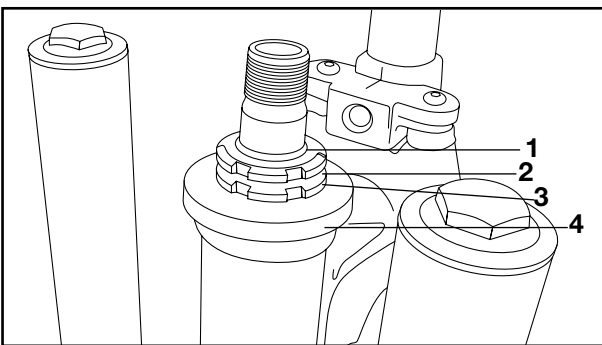

18. Remove:
- Lock washer ①
  - Ring nut 1 ②
  - Ring nut 2 ③
  - Cover ④

**NOTE:** \_\_\_\_\_

Remove the ring nut using the Ring Nut wrench



**Ring Nut Wrench:**  
90890-01403

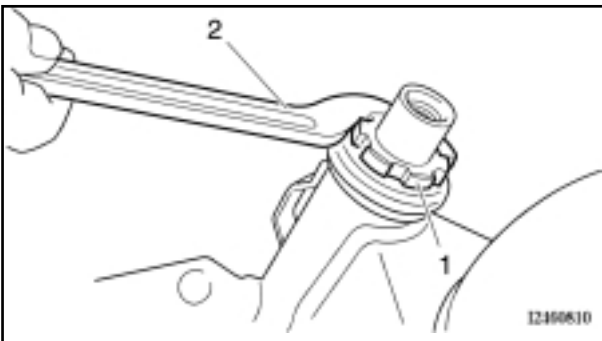

**⚠ WARNING** \_\_\_\_\_

Support the lower bracket so that it may not fall down

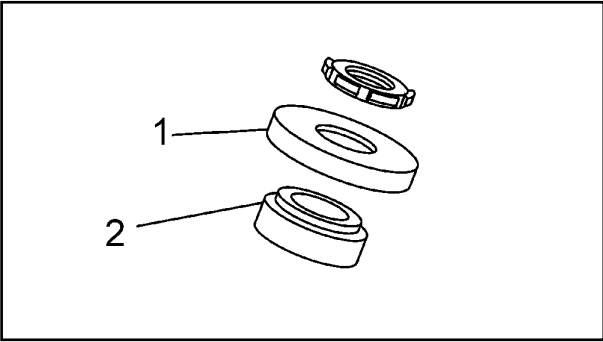

19. Remove:
- Bearing cover ①
  - Ball race (Top-Upper) ②
  - Ball bearing ③ (22pcs)

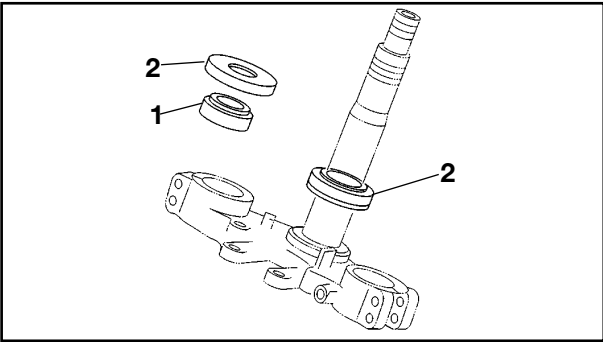

**INSPECTION**

1. Wash the bearing in solvent.
2. Inspect:
  - Bearings
  - Bearing races ②  
Pitting/Damage → Replace
  - Dust seal  
Wear/Damage → Replace



**Bearing race replacement steps:**

- Remove the bearing races on the head pipe using a long rod ① and the hammer as shown.
- Remove the bearing race on the steering stem using the floor chisel ② and the hammer as shown.
- Install the new dust seal and races.

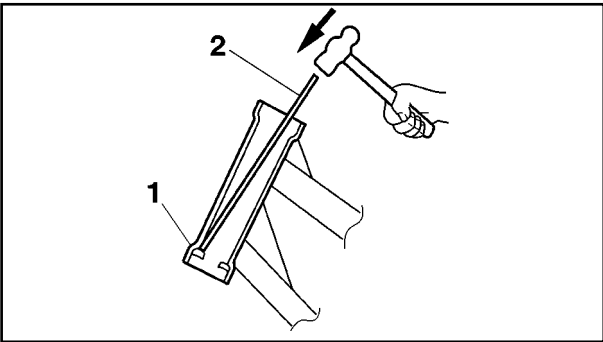

**NOTE:**

- Always replace bearings and races as a set
- Replace the dust seat whenever the steering head is disassembled.



**CAUTION**

**If the bearing race is fitted not squarely, the head pipe could be damaged**

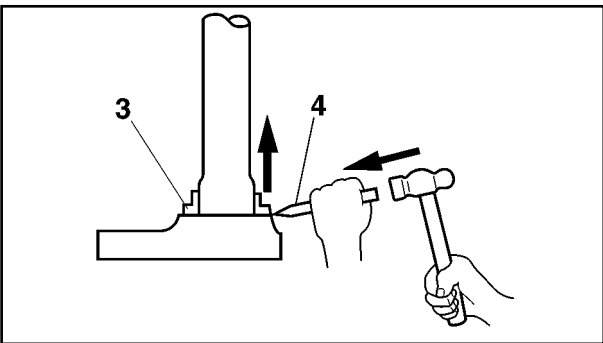

3. Inspect:
  - Handlebar crown ①
  - Under bracket ②  
with steering stem  
Cracks/Bend/Damage → Replace

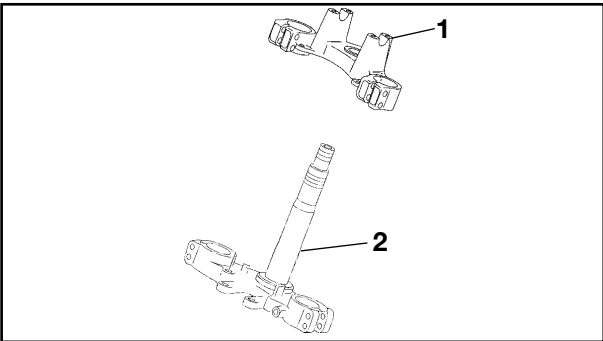

- 4. Inspect:
  - Handlebar
  - Cracks/Bend/Damage → Replace

**⚠ WARNING**

**Do not attempt to straighten a bent handlebar as this may dangerously weaken the handlebar.**



**Handlebar replacement steps:**

- Remove the handlebar grip and handlebar switch (Left) and lever holder.
- Install the lever holder and handlebar switch (Left) to a new handlebar.
- Apply a light coat of an adhesive for rubber on the left handlebar end.
- Install the handlebar grip.

**NOTE:**

Wipe off any excess adhesive with a clear rag

**⚠ WARNING**

**Leave the handlebar intact until the adhesive becomes dry enough to make the grip and handlebar stuck securely.**

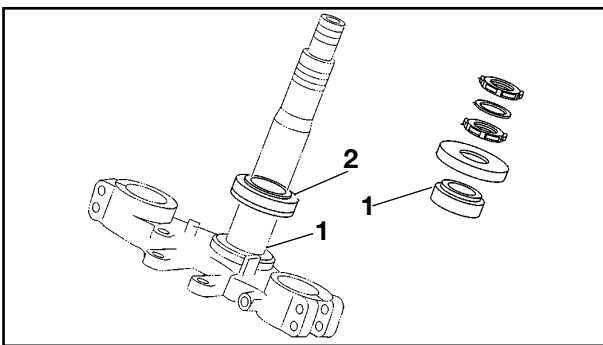

**INSTALLATION**

Reverse the "REMOVAL" procedures. Note the following points

1. Lubricate:
  - Bearing races ①
  - Bearings ②

	<b>Lithium Soap Base Grease</b>
---	---------------------------------

2. Install:
  - Ball bearings

**NOTE:**

Be sure the balls has the same size and the quantity is correct (22pcs)

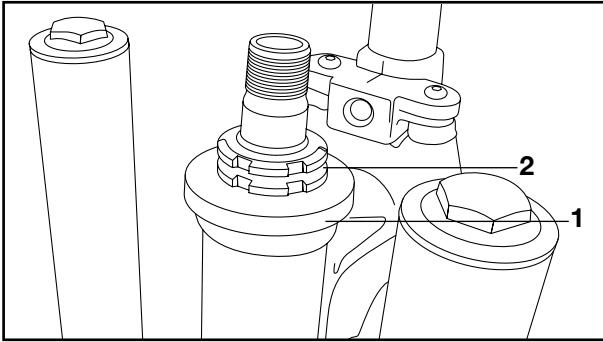

3. Install:
- Ball race (Upper-Lower)
  - Bearing cover ①
  - Under bracket
  - Ring nut ②

**⚠ WARNING**

**Hold the under bracket until its secured**

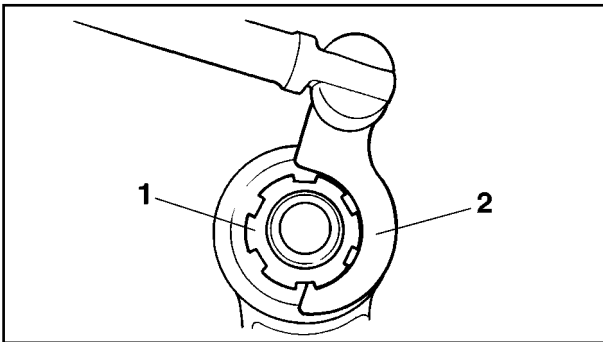

4. Tighten:
- Ring nut ①



**Tightening steps:**

- Tighten the ring nut using the Ring Nut Wrench ②

	<b>Ring Nut Wrench:</b> 90890-01403
--	--

**NOTE:**

Set the torque wrench to the right nut wrench so that they form a right angle

	<b>Ring Nut (Initial tightening):</b> 35Nm to 40Nm (3.5 to 4.0 m·kg, 25.6 to 29.3 ft·lb)
--	--

- Loosen the ring nut fully
- Retighten the ring nut using the Ring Nut Wrench

**⚠ WARNING**

**Avoid over tightening**

	<b>Ring Nut (Final tightening):</b> 3Nm to 5Nm (0.3 to 0.5 m·kg, 2.2 to 3.6 ft·lb)
--	--



5. Install:
- Handlebar crown ①
  - Flange nut (Steering stem) ②

**NOTE:**

Temporarily tighten the flange bol.

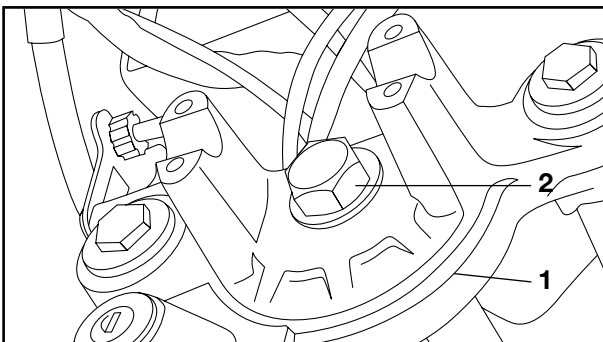

## INSTALLATION

CHAS

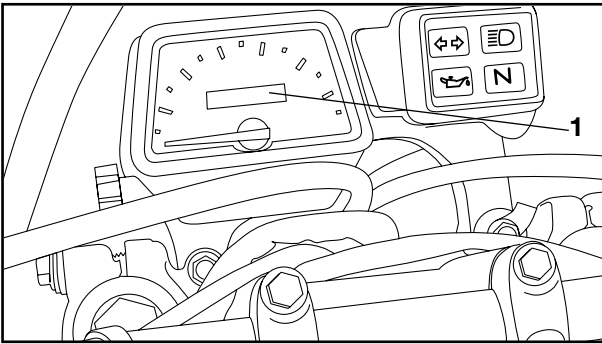

6. Install:
- Meter assembly ①



**Bolt (Meter assembly):**  
5Nm to 8Nm (0.5 to 0.8 m·kg, 3.6 to 5.8 ft·lb)

7. Install:
- Front fork  
Refer to the "FRONT FORK INSTALLATION" section.



**Pinch Bolt (Under Bracket):**  
20 to 25Nm (2.0 to 2.5 m·kg, 14.6 to 18.3 ft·lb)

### NOTE:

In this stage, temporarily tighten the pinch bolts (Handlebar crown).

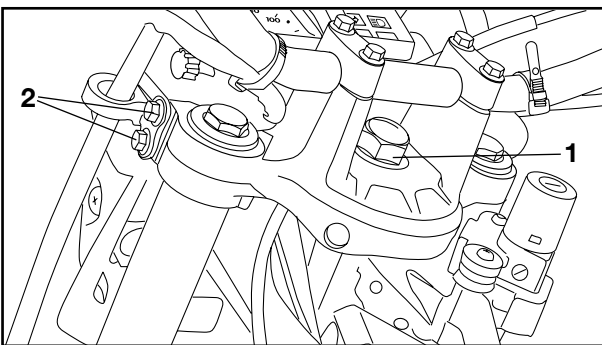

8. Tighten:
- Flange nut (Steering stem) ①
  - Pinch bolts (Handlebar crown) ②



**Flange nut (Steering stem):**  
120 to 155 Nm (12 a 15.5 m·kg, 88 to 110ft·lb)

**Pinch bolt (Handlebar crown):**  
12 to 28 Nm (1.2 to 2.8 m·kg, 8.80 to 20.5ft·lb)

### NOTE:

- Install the brake hose guide to the left side only.
- On the left side, install the flasher light having a chocolate color lead. Next, install the other flasher light with a dark green color lead.



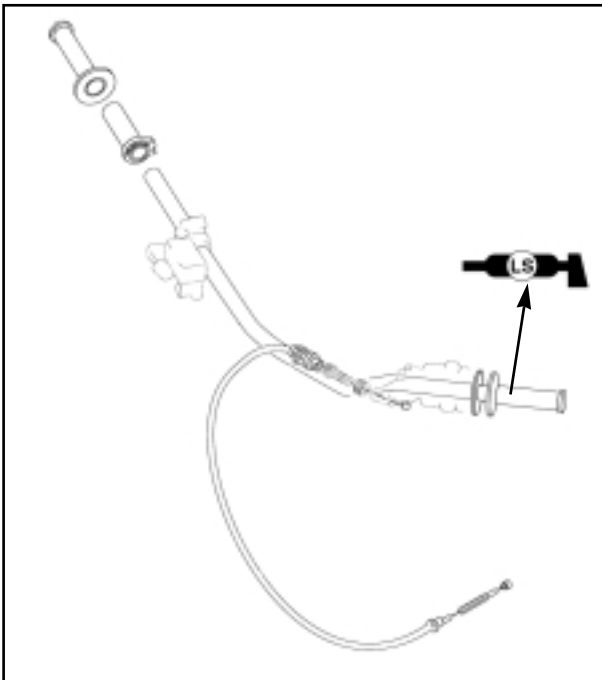
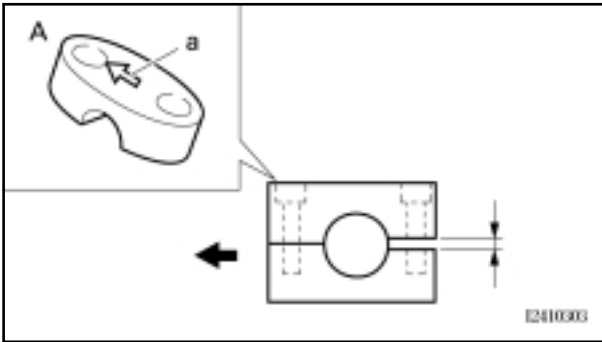

9. Install:
- Handlebar
  - Handlebar holders

	<p><b>Bolt (Handlebar holder):</b>  <b>12 to 28 Nm (1.2 a 2.8 m·kg, 8.80 to 20.5ft·lb)</b></p>
--	--

**NOTE:** \_\_\_\_\_  
 The handlebar should be installed in the position assigned by the position mark

**CAUTION** \_\_\_\_\_

**First tighten the bolts on the front side of the handlebar holder, and then tighten the bolts on the rear side.**

**NOTE:** \_\_\_\_\_  
 Before installing the handlebar onto the handlebar crown, apply a light coat of lithium soap base grease onto the handlebar end and install the throttle housing to the handlebar.

10. Install:
- Brake master cylinder

**NOTE:** \_\_\_\_\_

- Install the master cylinder bracket with the "UP" mark facing upward.
- Tighten first the upper bolt, then the lower bolt.

	<p><b>Bolts (Master cylinder bracket):</b>  <b>5 to 8 Nm (0.5 a 0.8 m·kg, 3.6 to 5,8ft·lb)</b></p>
--	--

11. Install:
- Clutch cable

**NOTE:** \_\_\_\_\_  
 Apply a light coat of lithium soap base grease onto the clutch cable end

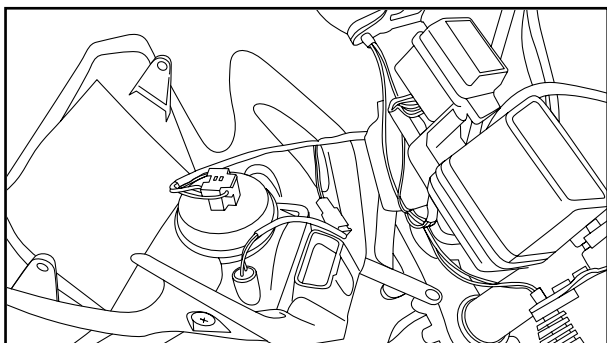

12. Install:
- Headlight lens unit

13. Install:
- Front wheel  
Refer to the "FRONT WHEEL INSTALLATION" section.

	<p><b>Front wheel axle:</b> 80 to 100 Nm (8.0 a 10.0 m·kg, 58.6 to 73.3ft·lb)</p> <p><b>Axle security bolts:</b> 7.5 to 12 Nm (0.75 to 1.2 m·kg, 5.5 to 8.8.5ft·lb)</p>
--	---

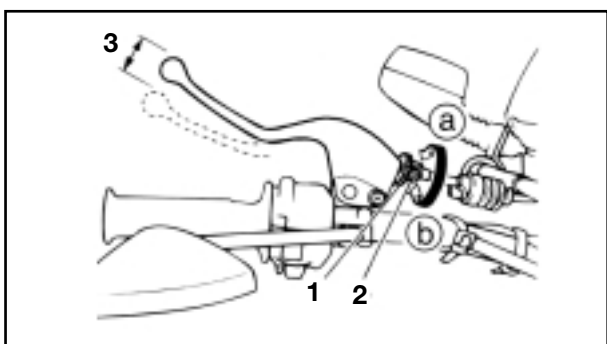

14. Adjust:
- Clutch cable free play ③  
Refer to the "CLUTCH ADJUSTMENT" section in chapter 3.

	<p><b>Free play:</b> 2~3mm (0.08~0.12in)</p>
--	--

# REAR SHOCK ABSORBER AND SWINGARM

CHAS



## REAR SHOCK ABSORBER AND SWINGARM

- ① Rear shock absorber assembly
- ② Spring
- ③ Bush

A	SPRING PRELOAD (INSTALLED): FOR DT125RE STANDARD LENGTH: 230 mm MINIMUM LENGTH: 220 mm MAXIMUM LENGTH: 235 mm
---	--

A	SPRING PRELOAD (INSTALLED): FOR DT125X STANDARD LENGTH: 244 mm MINIMUM LENGTH: 234 mm MAXIMUM LENGTH: 249 mm
---	---

 **30 to 35 Nm (3,0 to 3,5 m • kg,  
22 to 25,6 ft•lb)**

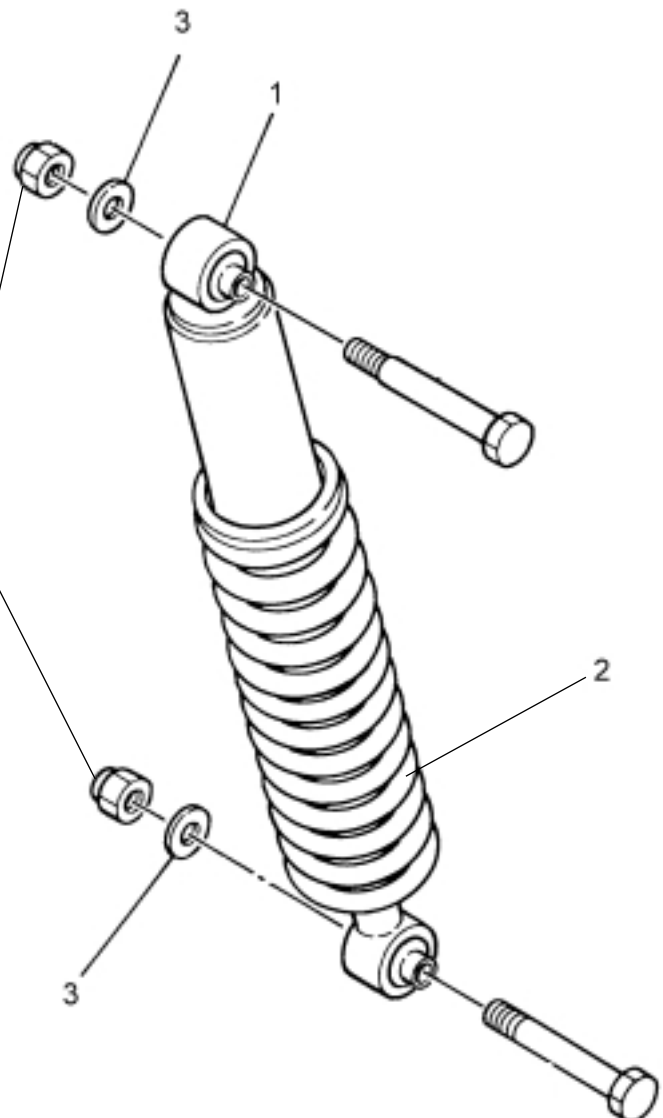

# REAR SHOCK ABSORBER AND SWINGARM

CHAS



- ① Swingarm
- ② Relay arm
- ③ Connecting arm
- ④ Chain case
- ⑤ Chain guard
- ⑥ Chain guide
- ⑦ Collar
- ⑧ Bearing
- ⑨ Oil seal
- ⑩ Bush
- ⑪ Plain washer
- ⑫ Shim
- ⑬ Thrust cover

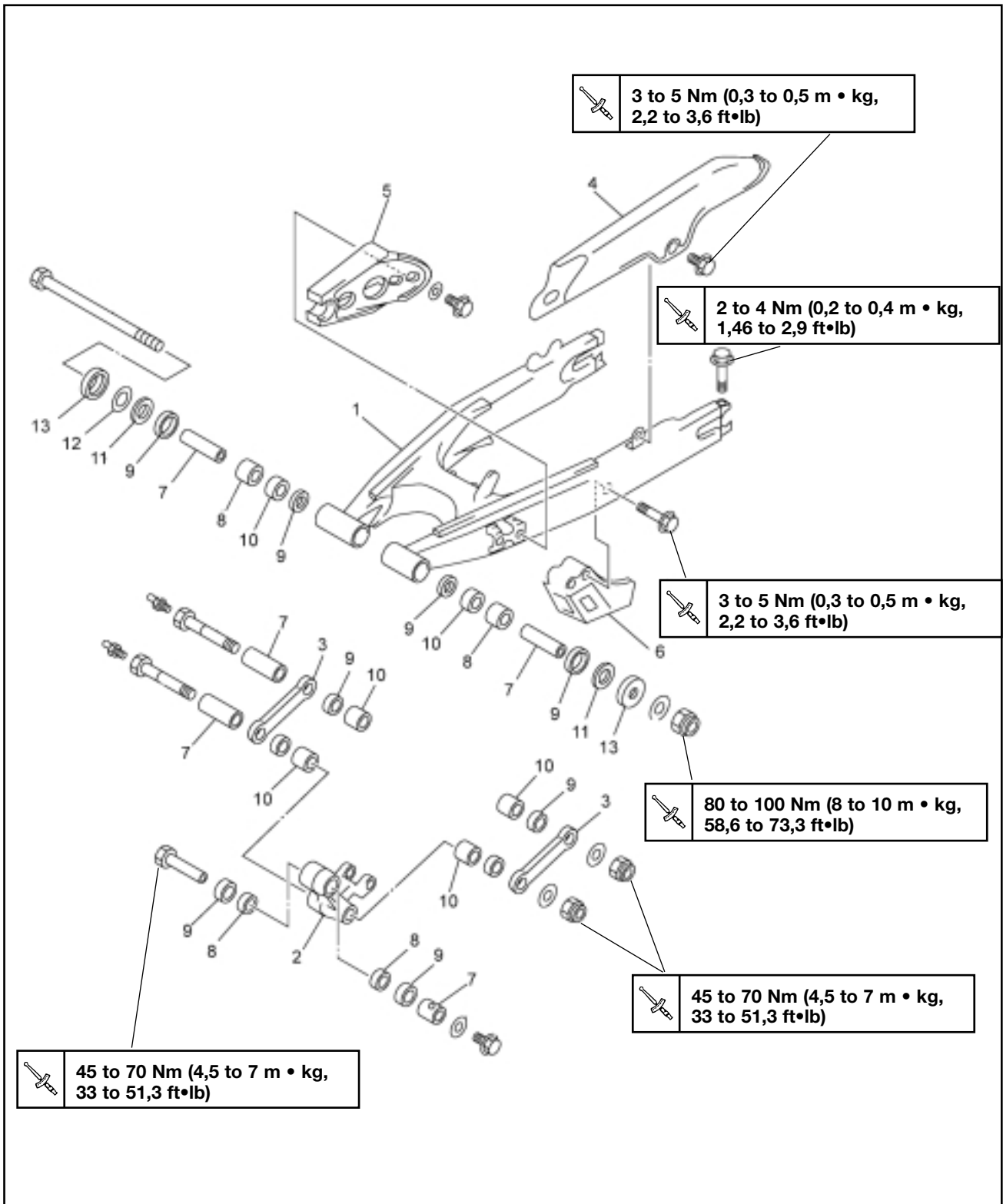

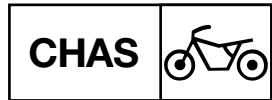

EAS00686

## HANDLING THE REAR SHOCK ABSORBER

### WARNING

This rear shock absorber contains highly compressed nitrogen gas. Before handling the rear shock absorber, read and make sure you understand the following information. The manufacturer cannot be held responsible for property damage or personal injury that may result from improper handling of the rear shock absorber.

- Do not tamper or attempt to open the rear shock absorber.
- Do not subject the rear shock absorber to an open flame or any other source of high heat. High heat can cause an explosion due to excessive gas pressure.
- Do not deform or damage the rear shock absorber in any way. Rear shock absorber damage will result in poor damping performance.

EAS00688

## DISPOSING OF A REAR SHOCK ABSORBER

Gas pressure must be released before disposing of a rear shock absorber. To release the gas pressure, drill a 2 ~ 3-mm hole through the rear shock absorber at a point 15 ~ 20 mm from its end as shown.

### WARNING

Wear eye protection to prevent eye damage from released gas or metal chips.

EAS00690

## REMOVING THE REAR SHOCK ABSORBER ASSEMBLY

1. Stand the motorcycle on a level surface.

### WARNING

Securely support the motorcycle so that there is no danger of it falling over.

## REMOVING THE REAR SHOCK ABSORBER ASSEMBLY

CHAS



**NOTE:** \_\_\_\_\_

Place the motorcycle on a suitable stand so that the rear wheel is elevated.

\_\_\_\_\_

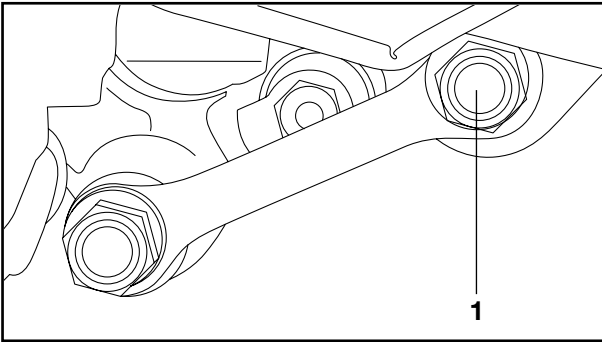

2. Remove:
- Bolt (Connecting arm swingarm) ① (from swingarm side)

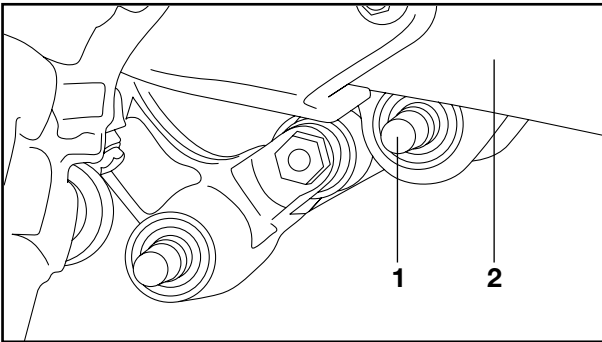

3. Remove:
- Bolt (Shock absorber → Lower)

**⚠ WARNING** \_\_\_\_\_

When removing the lower bolt ① hold the swingarm ② so that it does not drop downwards when the lower bolt is removed.

\_\_\_\_\_

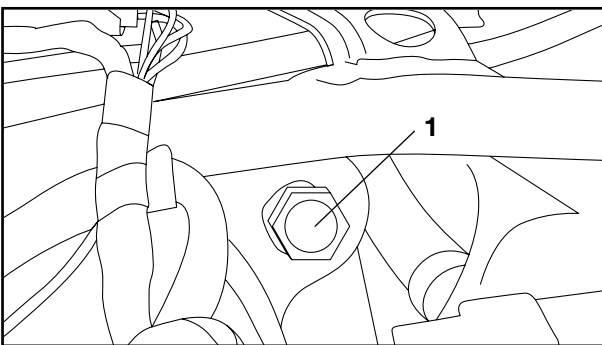

4. Remove:
- Bolt (Shock absorber → Upper) ①

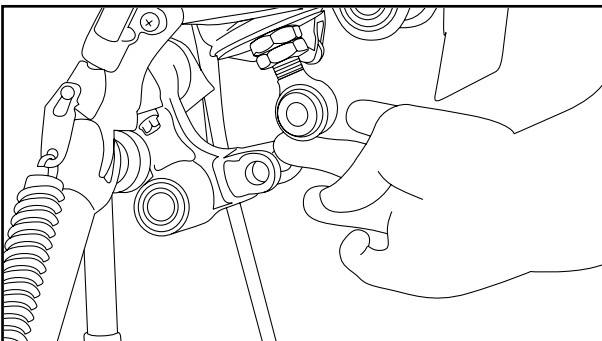

5. Remove:
- Rear shock absorber

**NOTE:** \_\_\_\_\_

Pull up the swingarm, then remove the rear shock absorber, through between the swingarm and relay arm

\_\_\_\_\_



## REMOVING THE SWINGARM ASSEMBLY

### **⚠ WARNING**

Securely support the motorcycle so there is no danger of falling it over

1. Elevate the rear wheel by placing a suitable stand under the engine.

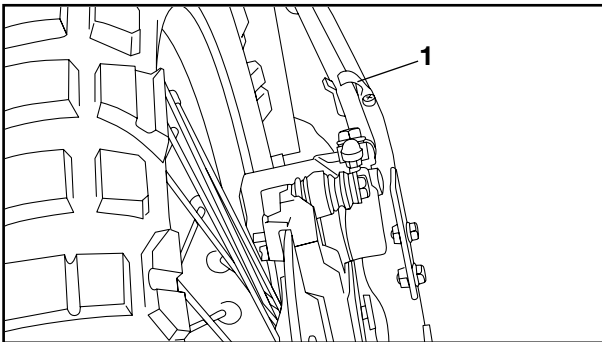

2. Remove:

- Rear shock absorber  
Refer to the "REAR SHOCK ABSORBER" section.

3. Remove:

- Rear wheel  
Refer to the "REAR WHEEL REMOVAL" section.

4. Remove:

- Brake hose guides ①
- Mud guard

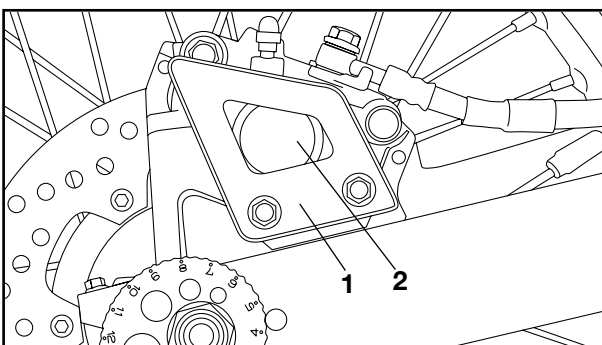

5. Remove:

- Protector (Brake caliper) ①
- Brake caliper assembly ②

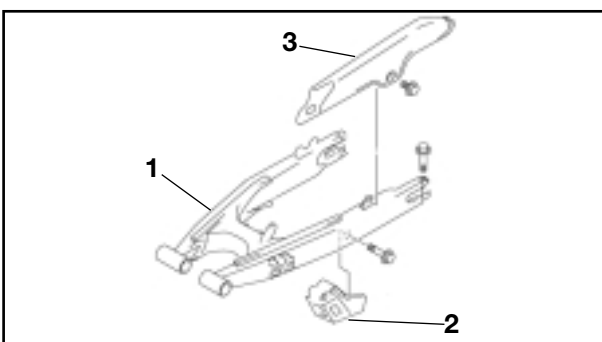

6. Remove:

- Chain case ①
- Chain guide ②
- Chain guard ③

# REMOVING THE SWINGARM ASSEMBLY

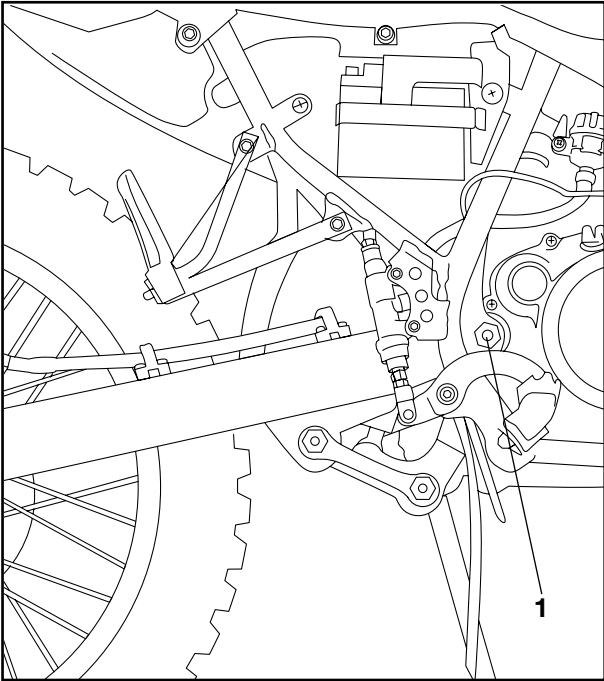

7. Check:
- Swingarm free play



**Inspection steps**

- Check the tightening torque of the pivot shaft (swingarm) securing nut ①

	<p><b>Nut (Swingarm-Pivot shaft):</b>  <b>80 to 100Nm (8 to 10 m·kg; 58.6 to 73.3lb-ft)</b></p>
---	---

- Check the swingarm side play by moving it from side to side.  
 If side play noticeable, check the inner collar, bearing, bushing and thrust over, or adjust the shim.

	<p><b>Side play (At the end of the swingarm):</b>  <b>1mm (0.04in)</b></p>
---	--

- Check the swingarm vertical movement by moving it up and down.  
 If vertical movement is tight, binding or rough, check the inner collar, bearing, bushing and thrust cover or adjust the shim.

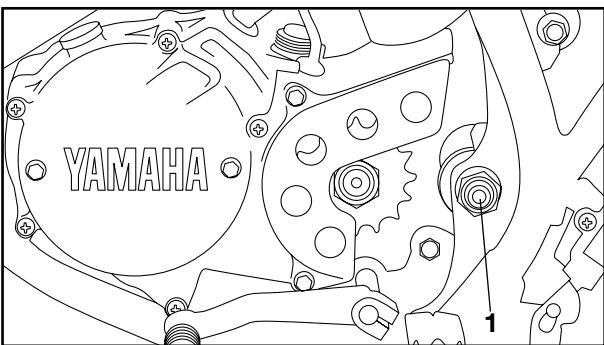

8. Remove:
- Pivot shaft ①
  - Swingarm

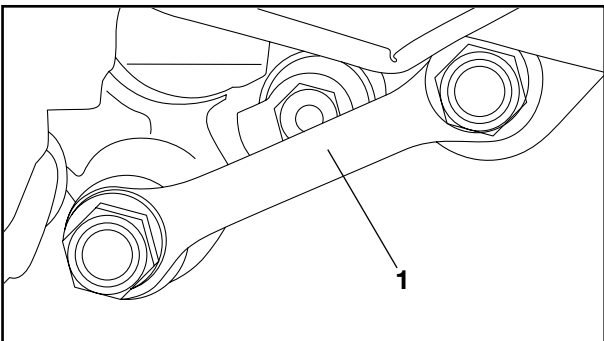

9. Remove:
- Connecting arm ①



## REMOVING THE SWINGARM ASSEMBLY

CHAS



10. Remove:
- Relay arm

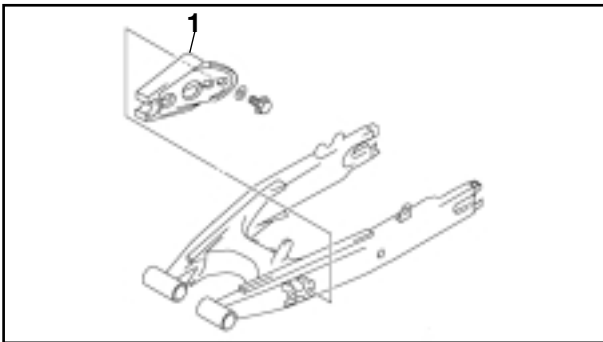

11. Remove:
- Chain protector ①

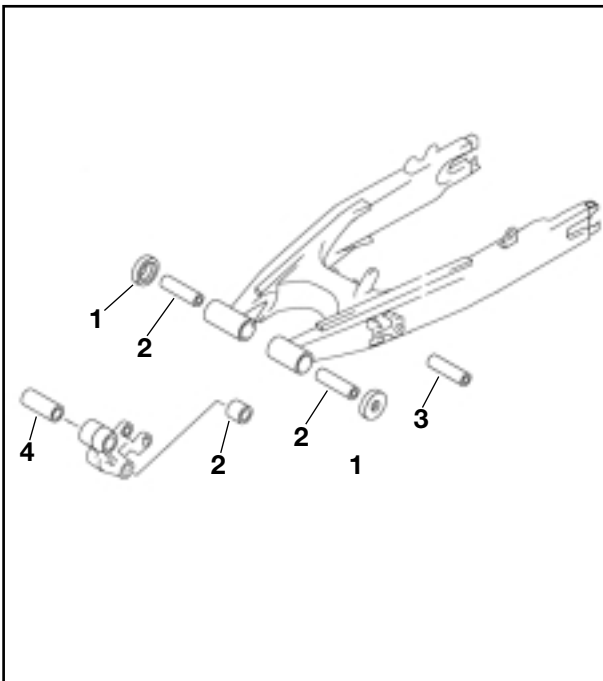

12. Remove:
- Thrust covers ①
  - Inner collars (Swingarm) ②
  - Inner collars (Connecting arm) ③
  - Inner collar (Relay arm) ④

## CHECKING THE REAR SHOCK ABSORBER ASSEMBLY

CHAS

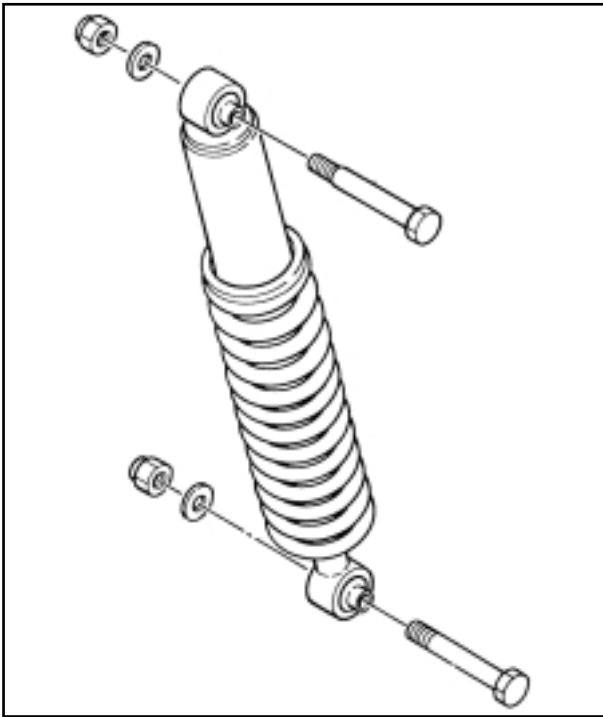

EAS00695

### CHECKING THE REAR SHOCK ABSORBER ASSEMBLY

1. Check:

- rear shock absorber rod  
Bends/damage → Replace the rear shock absorber assembly.
- rear shock absorber  
Gas leaks/oil leaks → Replace the rear shock absorber assembly.
- spring  
Damage/wear → Replace the rear shock absorber assembly.
- bushings  
Damage/wear → Replace.
- dust seals  
Damage/wear → Replace.
- bolts  
Bends/damage/wear → Replace.

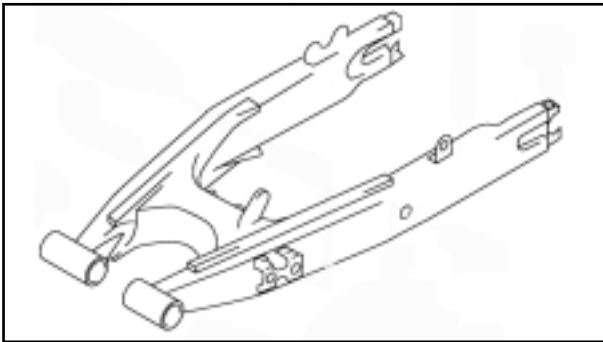

EAS00707

### CHECKING THE SWINGARM

1. Check:

- swingarm  
Bends/cracks/damage → Replace.

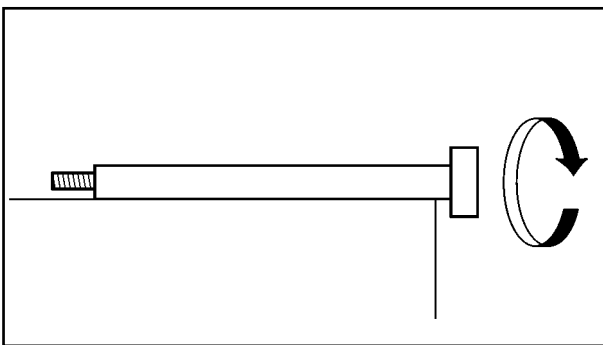

2. Check:

- pivot shaft  
Roll the pivot shaft on a flat surface.  
Bends → Replace.

**⚠ WARNING**

**Do not attempt to straighten a bent pivot shaft.**

3. Wash:

- pivot shaft
- dust covers
- spacer
- washers
- bearings

**Recommended cleaning solvent  
Kerosene**

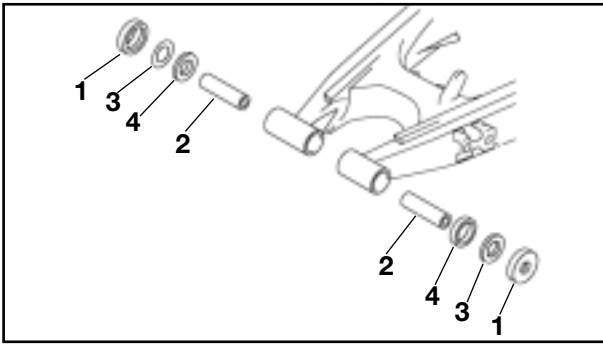

4. Check:
- dust covers ①
  - spacer ②
  - washers ③
  - oil seals ④
- Damage/wear → Replace.
- bearings
- Damage/pitting → Replace.

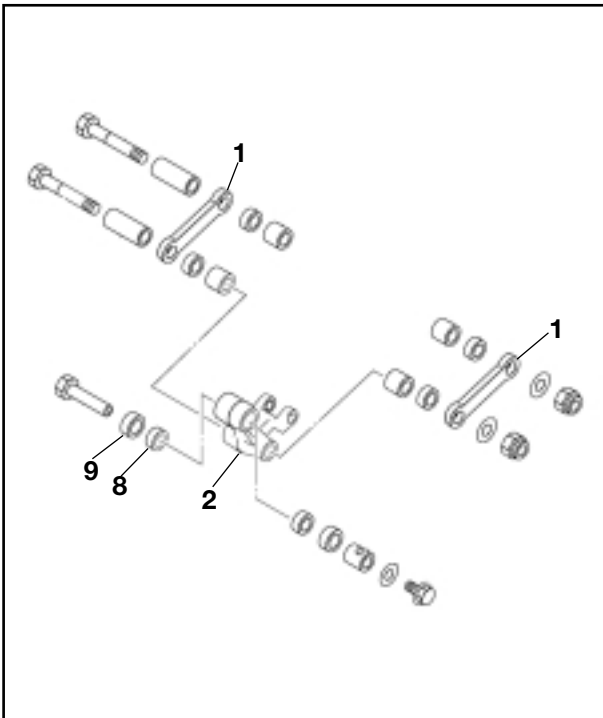

5. Check:
- connecting arms ①
  - relay arm ②
- Damage/wear → Replace.

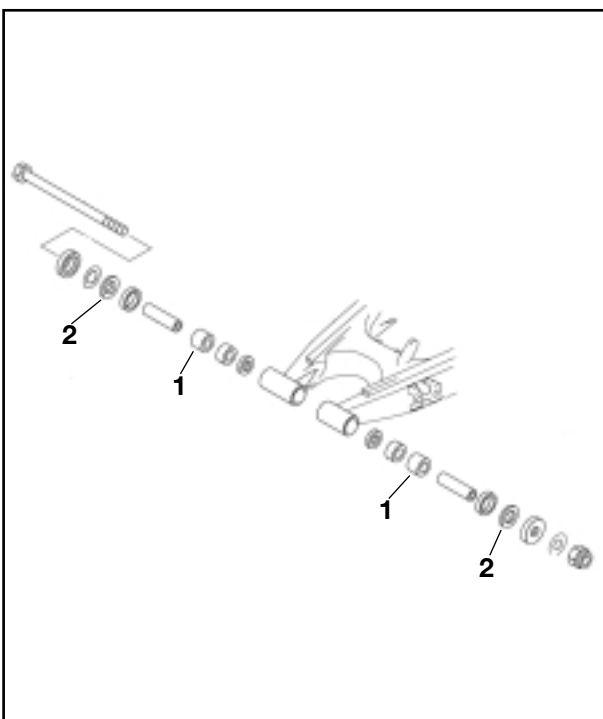

6. Check:
- bearings ①
  - oil seals ②
- Damage/pitting → Replace.



7. Check:
  - spacersDamage/scratches → Replace.

EAS00711

## INSTALLING THE SWINGARM

1. Lubricate:
  - bearings
  - spacers
  - dust covers
  - pivot shaft



**Recommended lubricant**  
**Molybdenum disulfide grease**

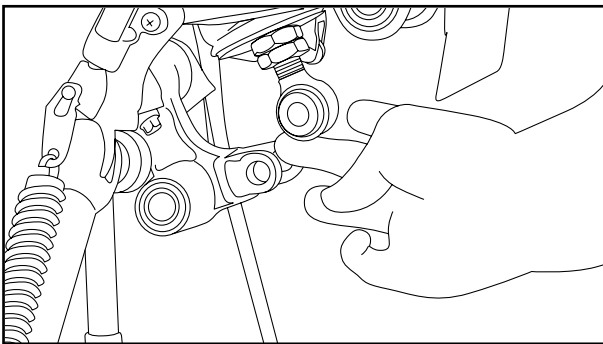

2. Install:
  - relay arm



**45 to 70 Nm (4.5 to 7.0m•kg, 33 to 95.5ft•lb)**

- connecting arms



**45 to 70 Nm (4.5 to 7.0m•kg, 33 to 95.5ft•lb)**

**NOTE:** \_\_\_\_\_

Install the connecting arm front bolt (4) from the right.

\_\_\_\_\_

3. Install:
  - rear shock absorber assembly
  - rear wheelRefer to “INSTALLING THE REAR SHOCK ABSORBER ASSEMBLY” and “INSTALLING THE REAR WHEEL”.

## INSTALLING THE SWINGARM

CHAS



4. Adjust:

- drive chain slack

Refer to “ADJUSTING THE DRIVE CHAIN SLACK” in chapter 3.



**Drive chain slack**

**DT125RE 40~55mm (1,77~2,16in.)**

**DT125X 25~40mm (0,98~1,58 in.)**

# DRIVE CHAIN AND SPROCKETS

CHAS



## DRIVE CHAIN AND SPROCKETS

- ① Drive sprocket
- ② Chain joint
- ③ Drive chain

A	DRIVE CHAIN
B	TYPE
	428V2
C	No. OF LINKS
	134
D	DRIVE CHAIN SLACK DT125RE
	45-55mm (1,77~2,16in)
E	DRIVE CHAIN SLACK DT125X
	25-40mm (0,984~1,575in)

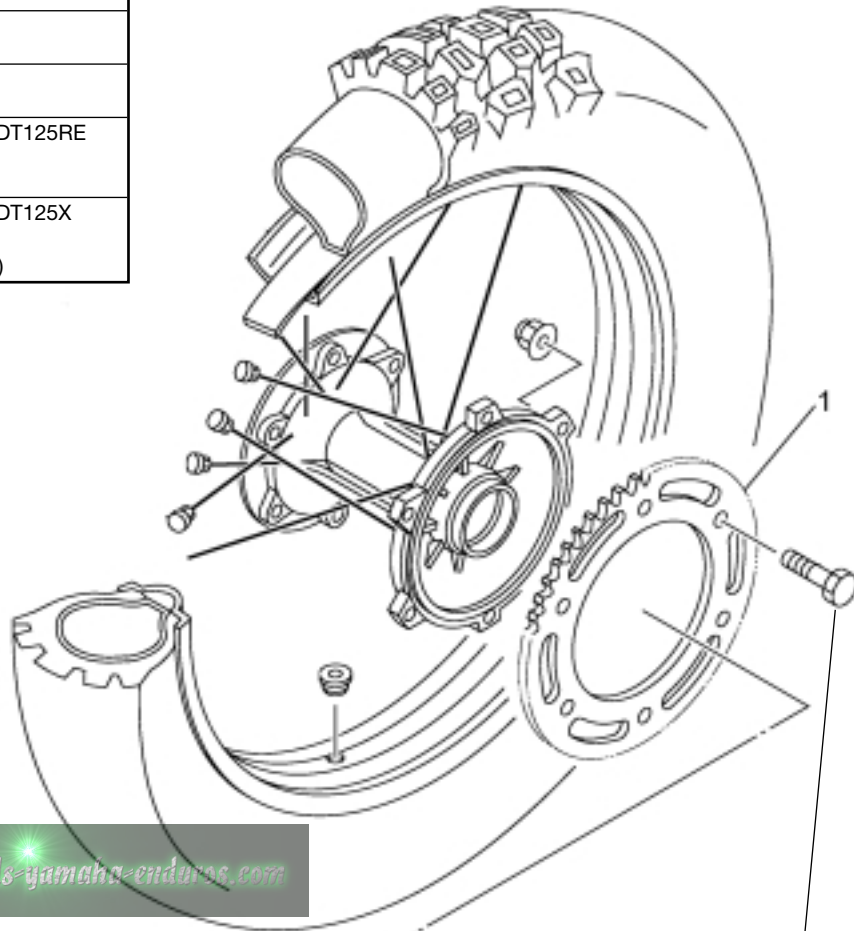

 32 to 37 Nm (3,2 to 3,7 m • kg,  
23,5 to 27,1 ft•lb)

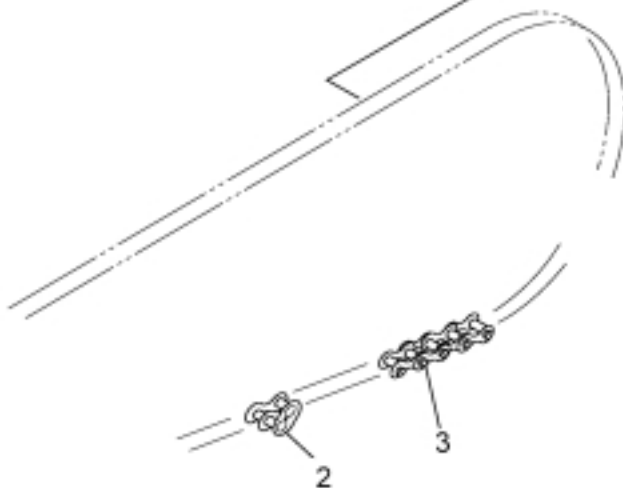



## REMOVING THE DRIVE CHAIN

1. Stand the motorcycle on a level surface.

**⚠ WARNING**

Securely support the motorcycle so that there is no danger of it falling over.

**NOTE:**

Place the motorcycle on a suitable stand so that the rear wheel is elevated.

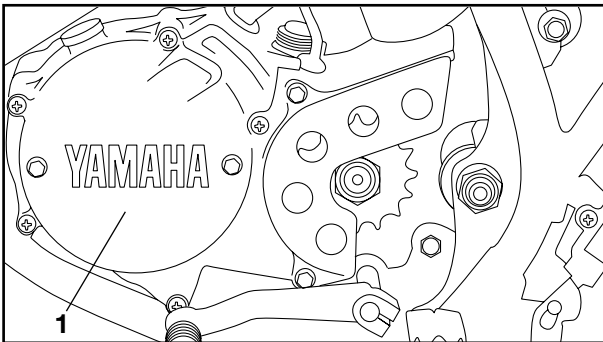

2. Remove:

- Crankcase cover (left) ①

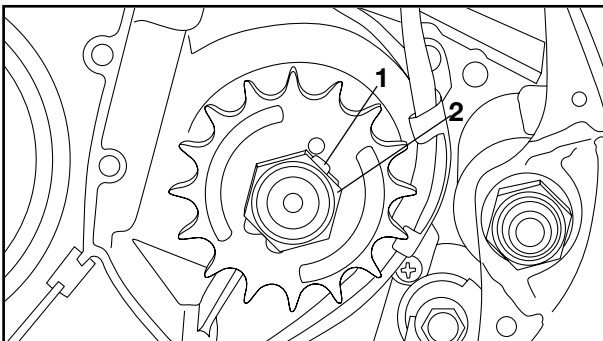

3. Straighten:

- Lock washer tab ①

4. Loosen:

- Nut (drive sprocket) ②

**NOTE:**

When loosening the drive sprocket nut, apply the rear brake pedal and transmission gear to the 6th position.

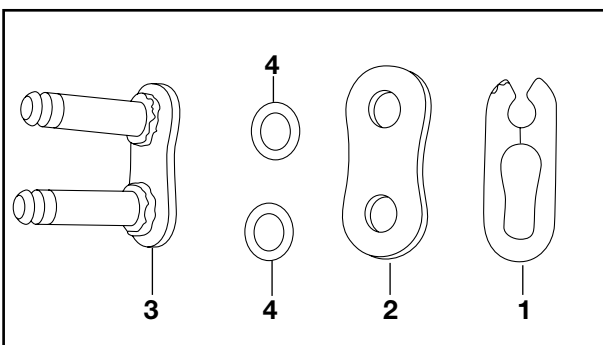

5. Remove:

- Clip (master link) ①
- Plate (master link) ②
- master link ③
- O-rings ④
- Drive chain

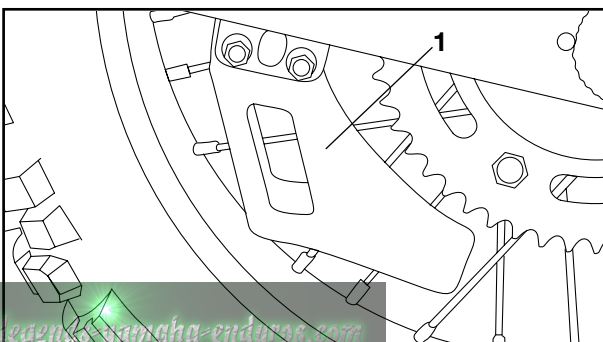

6. Remove:

- Chain guide ①
- Drive sprocket

7. Remove:

- Rear wheel  
Refer to the "REAR WHEEL REMOVAL" section.

# REMOVING THE DRIVE CHAIN/CHECKING THE DRIVE CHAIN

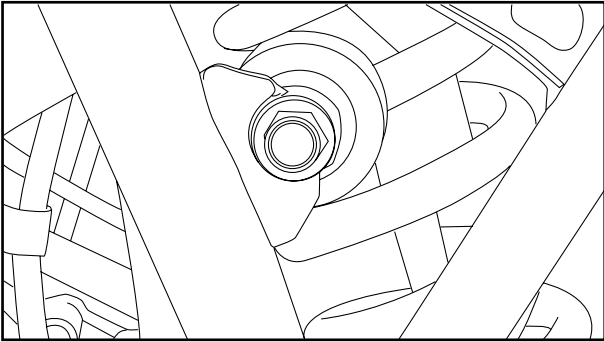

8. Remove:
  - Chain guide rollers (Upper and lower)

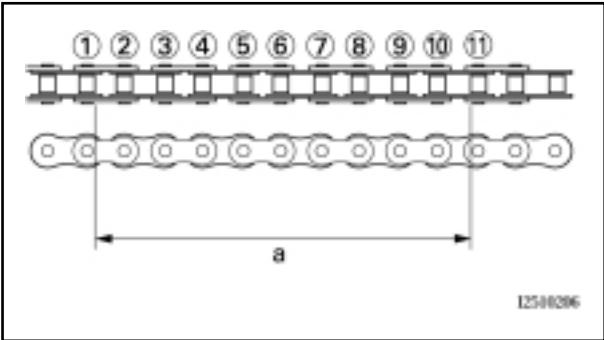

EAS00709

## CHECKING THE DRIVE CHAIN

1. Measure:
  - ten-link section @ of the drive chain
  - Out of specification → Replace the drive chain.



**Ten-link drive chain section limit (maximum)**  
120 mm (4.72 in)

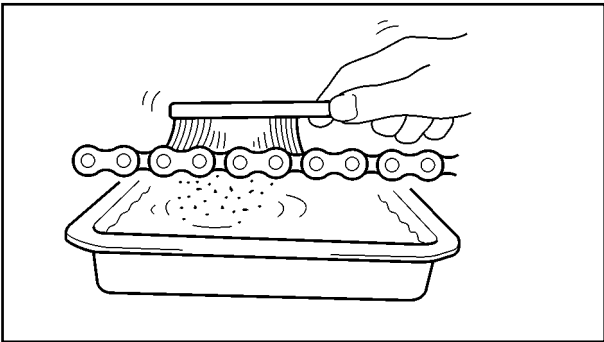

2. Check:
  - drive chain
  - Stiffness → Clean and lubricate or replace.

3. Clean:
  - drive chain



- a. Wipe the drive chain with a clean cloth.
- b. Put the drive chain in kerosene and remove any remaining dirt.
- c. Remove the drive chain from the kerosene and completely dry it.



# CHECKING THE DRIVE CHAIN

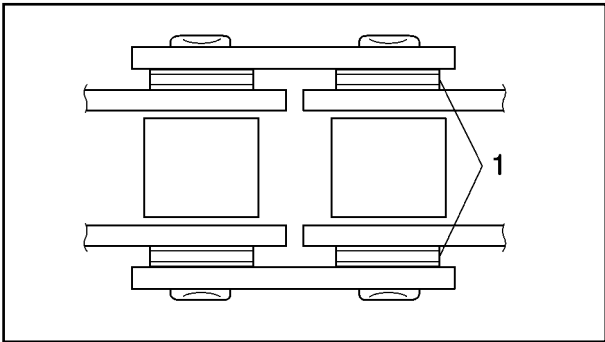
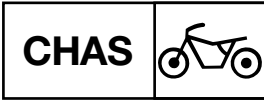

### CAUTION

This motorcycle has a drive chain with small rubber O-rings ① between the drive chain side plates. Never use high-pressure water or air, steam, gasoline, certain solvents (e.g., benzene), or a coarse brush to clean the drive chain. High-pressure methods could force dirt or water into the drive chain's internals, and solvents will deteriorate the O-rings. A coarse brush can also damage the O-rings. Therefore, use only kerosene to clean the drive chain. Don't soak drive chain in kerosene more than ten minutes. O-ring is damage by kerosene.

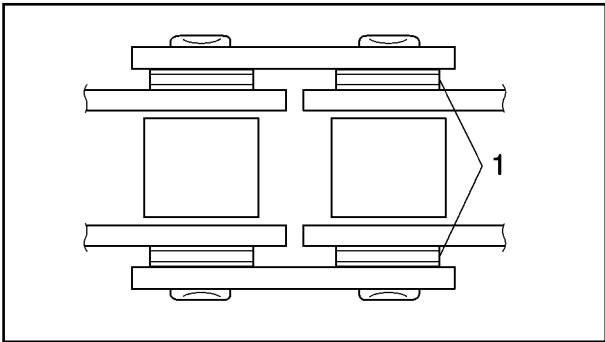

4. Check:
  - O-rings ①  
Damage → Replace the drive chain.
  - drive chain rollers ②  
Damage/wear → Replace the drive chain.
  - drive chain side plates ③  
Damage/wear → Replace the drive chain.  
Cracks → Replace the drive chain and make sure the battery breather hose is properly routed away from the drive chain and below the swingarm.

5. Lubricate:
  - drive chain

**Recommended lubricant**  
Engine oil or chain lubricant suitable for O-ring chains

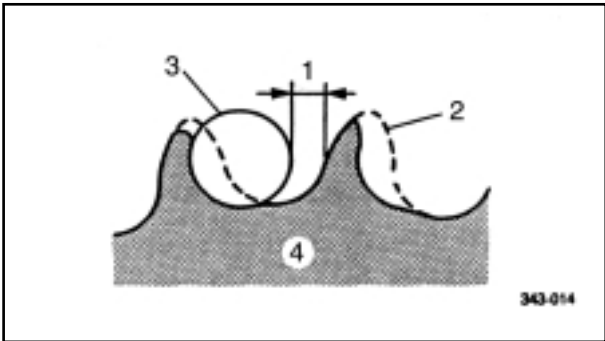

6. Check:
  - drive sprocket
  - rear wheel sprocket  
More than 1/4 tooth @ wear → Replace the drive chain sprockets as a set.  
Bent teeth → Replace the drive chain sprockets as a set.

- ⓑ Correct
- ① Drive chain roller
- ② Drive chain sprocket



EAS00713

## INSTALLING THE DRIVE CHAIN

- Lubricate:
  - drive chain
  - master link <NEW>



**Recommended lubricant**  
 Engine oil or chain lubricant suitable for O-ring chains

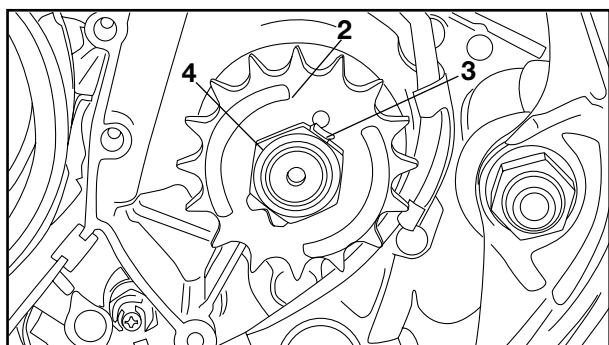

- Install:
  - drive chain
  - drive sprocket ②
  - washer ③
  - drive sprocket nut ④



**60 Nm (6.0 m•kg, 43 ft•lb)**

**NOTE:**

While applying the rear brake, tighten the drive sprocket nut.

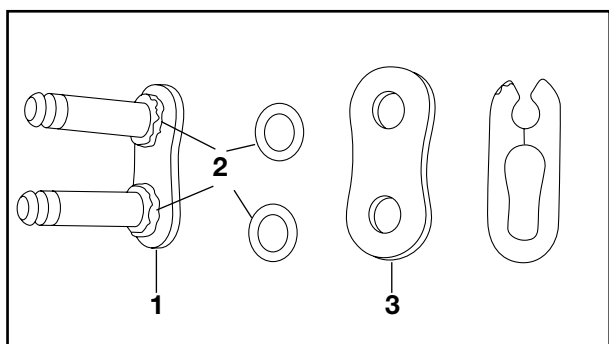

- Install:
  - master link ①
  - O-ring ②
  - master link plate ③ (with a drive chain cutter)

**CAUTION**

Never install a new drive chain onto worn drive chain sprockets; this will dramatically shorten the drive chain's life.

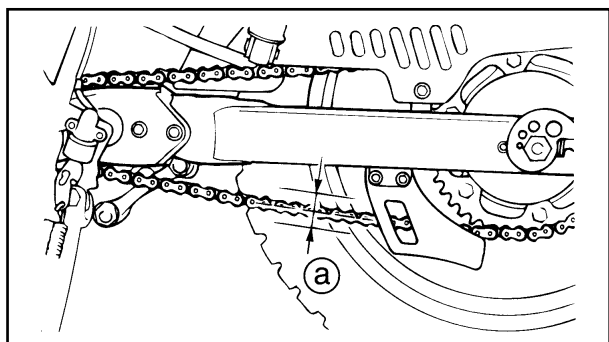

- Adjust:
  - drive chain slack  
 Refer to "ADJUSTING THE DRIVE CHAIN SLACK" in chapter 3.



**Drive chain slack DT125RE**  
 45 ~ 55 mm (1.77 ~ 2.16 in)  
**Drive chain slack DT125X**  
 25 ~ 40 mm (0.984 ~ 1.575 in)

## INSTALLING THE DRIVE CHAIN

---

CHAS



### CAUTION

A drive chain that is too tight will overload the engine and other vital parts, and one that is too loose can skip and damage the swingarm or cause an accident. Therefore, keep the drive chain slack within the specified limits.

---



**ENG**

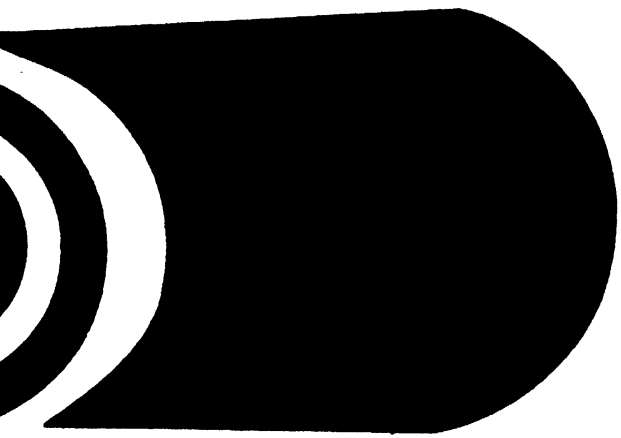

5



## CHAPTER 5 ENGINE

<b>ENGINE REMOVAL</b> .....	5-1
SIDE COVERS .....	5-1
COOLANT .....	5-1
TRANSMISSION OIL .....	5-1
EXHAUST PIPE .....	5-2
CARBURETOR .....	5-2
AUTOLUBE PUMP CABLE AND HOSE .....	5-2
CLUTCH CABLE .....	5-3
Y.P.V.S. CABLES .....	5-3
RADIATOR HOSE.....	5-4
LEADS .....	5-4
DRIVE CHAIN .....	5-5
 <b>ENGINE DISASSEMBLY</b> .....	 5-6
CYLINDER HEAD, CYLINDER AND PISTON .....	5-8
CLUTCH, PRIMARY DRIVE GEAR AND BALANCER GEAR .....	5-8
CLUTCH PUSH LEVER.....	5-11
SHIFT SHAFT AND STOPPER LEVER .....	5-11
MAGNETO ROTOR .....	5-12
REED VALVE .....	5-12
CRANKCASE (RIGHT) .....	5-13
SHIFTER, TRANSMISSION AND BALANCER WEIGHT .....	5-14
CRANKSHAFT .....	5-15
POWER VALVE .....	5-15
AUTOLUBE PUMP ASSEMBLY .....	5-16
 <b>INSPECTION AND REPAIR</b> .....	 5-17
CYLINDER HEAD .....	5-17
CYLINDER AND PISTON .....	5-18
PISTON RINGS .....	5-19
PISTON PIN AND BEARING .....	5-21
CLUTCH .....	5-21
PRIMARY DRIVE .....	5-24
TRANSMISSION AND SHIFTER .....	5-25
SHIFT SHAFT AND STOPPER LEVER .....	5-27
CRANKSHAFT .....	5-27
AUTOLUBE PUMP .....	5-28
POWER VALVE .....	5-29
CRANKCASE .....	5-30
 <b>ENGINE ASSEMBLY AND ADJUSTMENTS</b> .....	 5-31
AUTOLUBE PUMP .....	5-31
POWER VALVE .....	5-33
CRANKSHAFT AND BALANCER .....	5-35
TRANSMISSION AND SHIFTER .....	5-36
CRANKCASE (RIGHT) .....	5-39
REED VALVE .....	5-40
MAGNETO ROTOR .....	5-41
STOPPER LEVER AND SHIFT SHAFT .....	5-43
CLUTCH PUSH LEVER.....	5-46
BALANCER GEAR, PRIMARY DRIVE GEAR AND CLUTCH .....	5-47
PISTON CYLINDER AND CYLINDER HEAD.....	5-52
REMOUNTING ENGINE .....	5-56

**ENGINE OVERHAUL****ENGINE REMOVAL****NOTE:** \_\_\_\_\_

It's not necessary to remove the engine in order to remove the following components:

- Cylinder head
  - Cylinder
  - Piston and piston ring
  - Power valve
  - Clutch
  - Primary drive gear
  - Kick axle
  - Shift shaft
  - Magneto rotor
  - Stator
  - Autolube pump
- 

**SIDE COVERS**

1. Remove:
  - Side cover (right)
  - Side cover (left)
  - Seat

**COOLANT**

1. Drain:
  - CoolantRefer to the "COOLANT REPLACEMENT" section in chapter 3.

**TRANSMISSION OIL**

1. Drain:
  - Transmission oilRefer to the "TRANSMISSION OIL REPLACEMENT" section in chapter 3.

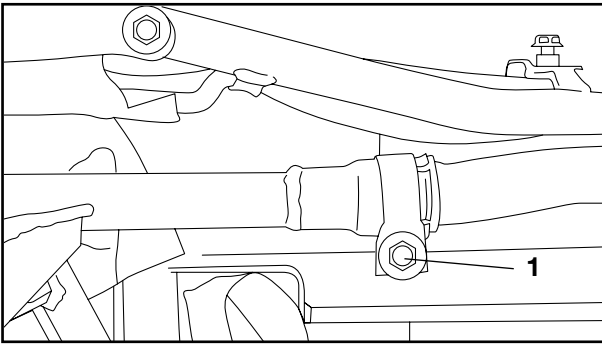

## EXHAUST PIPE

1. Loosen:
  - Bolts (Exhaust holder)
  - Screw (muffler joint) ①
2. Remove:
  - A.I.S. hose ①
  - Bolts (Exhaust pipe) ②
  - Exhaust pipe ③

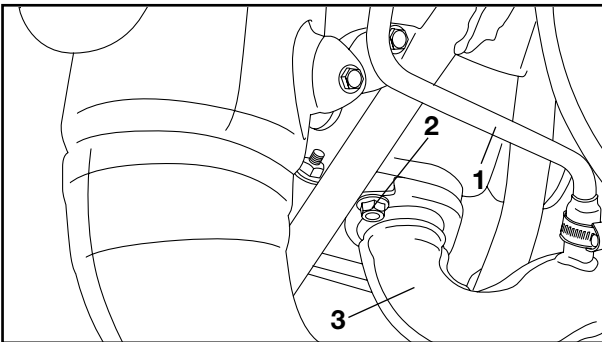

## CARBURETOR

1. Remove:
  - Fuel tank
  - Carburetor
 Refer to the "CARBURETOR REMOVAL" section in chapter 6.

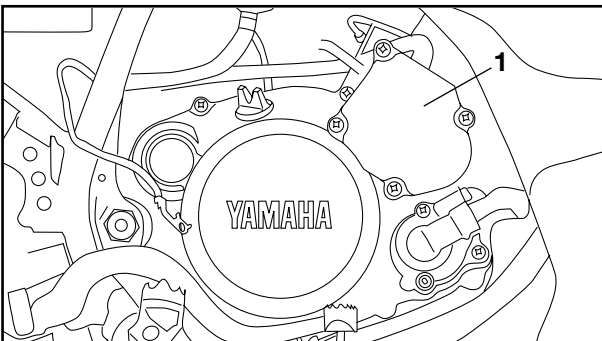

## AUTOLUBE PUMP CABLE AND HOSE

1. Remove:
  - Autolube pump cover ①

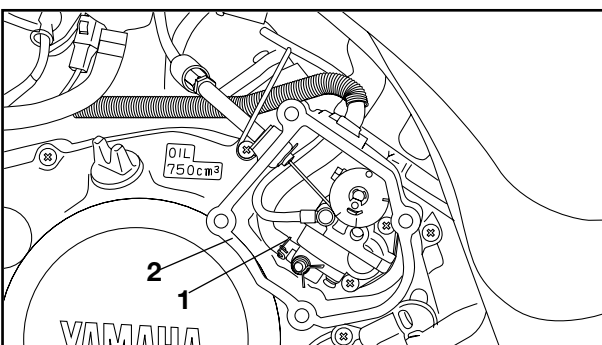

2. Disconnect:
  - hose ①  
(from autolube pump and hose guide)
  - Gasket (autolube pump cover) ②

### NOTE:

Plug the oil hose so that oil will not run out of the oil tank.

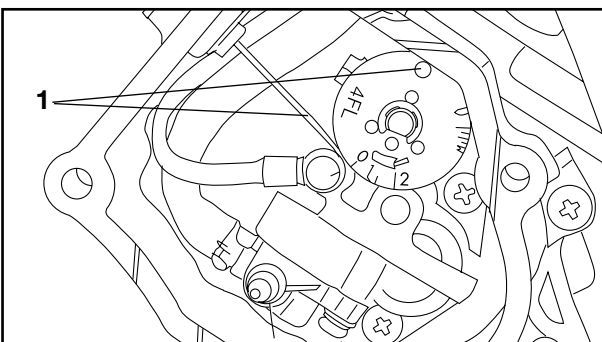

3. Remove:
  - Pump cable ①

### NOTE:

Turn the pump pulley clockwise by finger to make the pump cable loose enough for its end to be removed from the pulley.



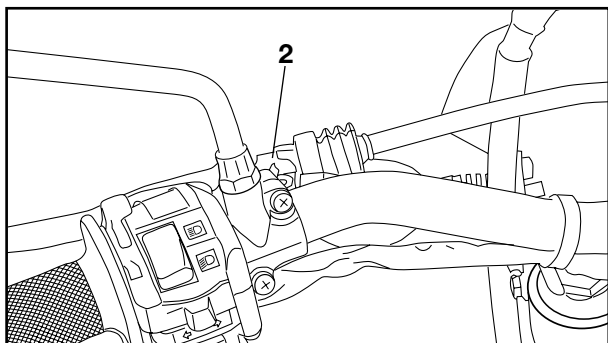

## CLUTCH CABLE

1. Loosen:
  - Adjuster (Clutch cable) ②

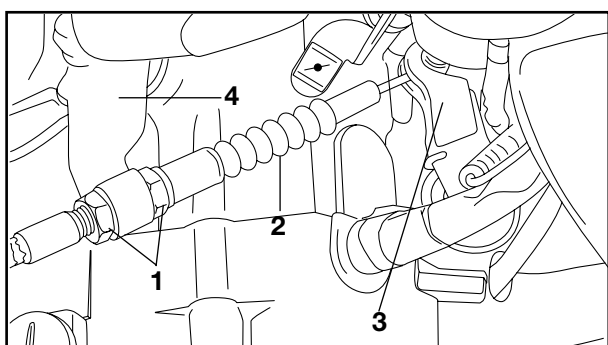

2. Loosen:
  - Adjuster lock nuts (Clutch cable) ①
3. Disconnect:
  - Clutch cable ② (from clutch push lever ③ and cable guide ④).

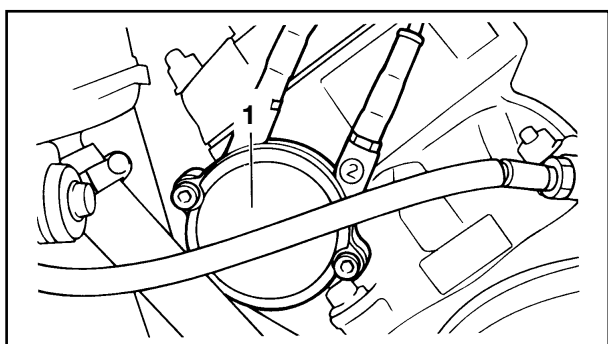

## Y.P.V.S. CABLES

1. Remove:
  - Pulley cover (Power valve) ①

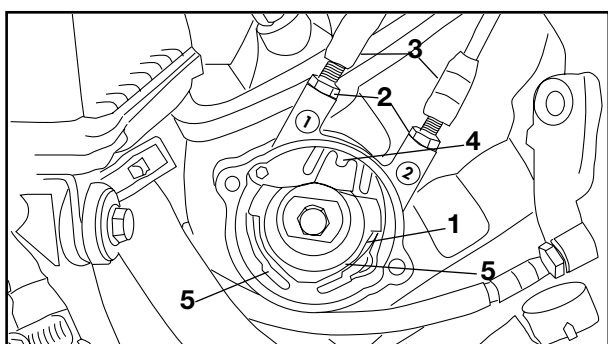

2. Remove:
  - Pulley (Power valve) ①



### Removal steps

- Loosen both locknuts ② and turn in both adjusters ③.
- Insert a pin (Ø4mm.(Ø0.16in)) through the aligning indent in the pulley ④ and into the hole to lock the pulley.
- Remove the pulley ① from the power valve and then disconnect the Y.P.V.S. cables ⑤ from the pulley.
- Remove the pin



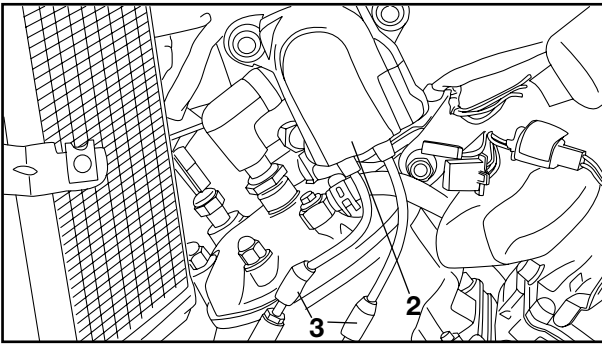

3. Disconnect:
  - Servomotor unit leads
4. Remove:
  - Servomotor unit ②
  - Adjuster (Y.P.V.S. cable) ③
  - Pulley housing

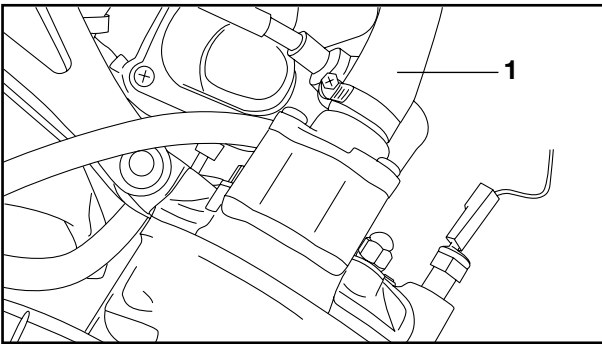

## RADIATOR HOSES

1. Disconnect:
  - Radiator hose (Inlet) ①

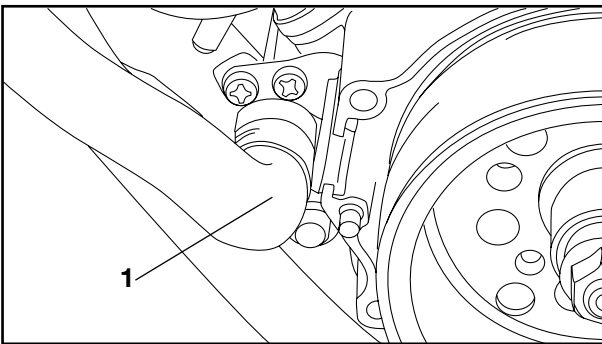

2. Disconnect:
  - Radiator hose (Outlet) ①

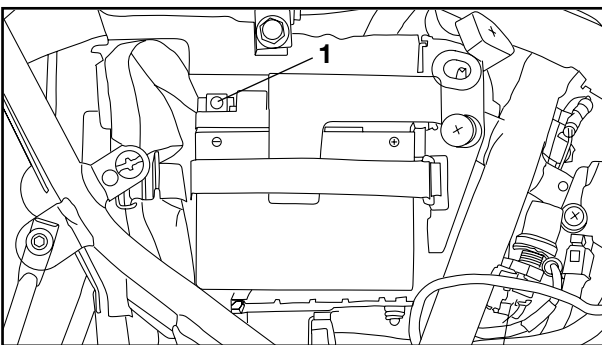

## LEADS

1. Disconnect:
  - Battery lead (Negative) ①

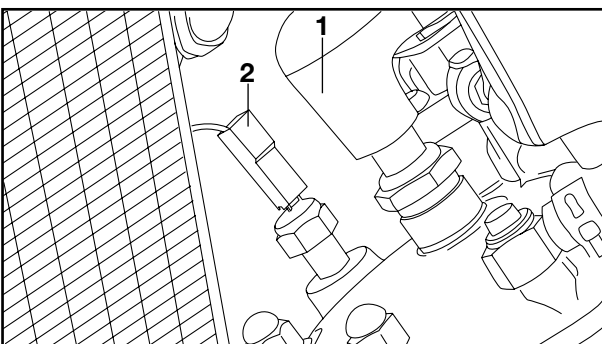

2. Disconnect:
  - Spark plug lead ①
  - Thermo unit lead ②

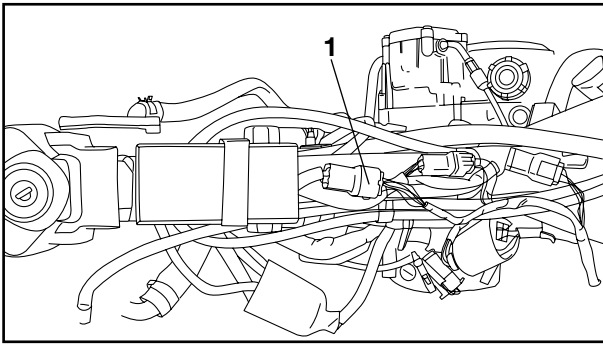

3. Disconnect:
  - CDI magneto leads ①

4. Remove:
  - Bands

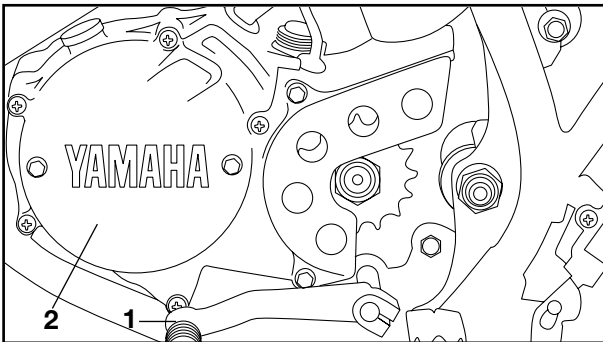

## DRIVE CHAIN

1. Remove:
  - Change pedal ①
  - Crankcase cover (Left) ②
  - Gasket (Crankcase cover)

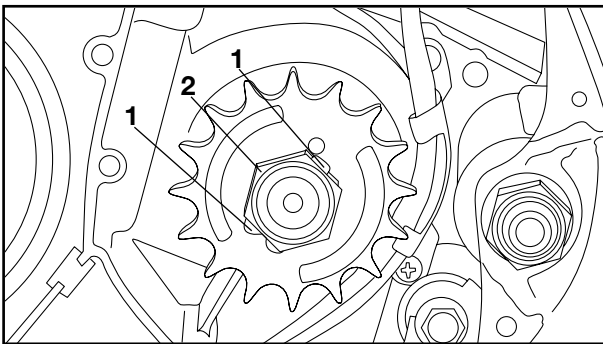

2. Straighten:
  - Lock washer tab ①
3. Loosen:
  - Nut (Drive sprocket) ②

## NOTE:

When loosening the nut (Drive sprocket) apply the rear brake pedal and transmission gear to the 6th position

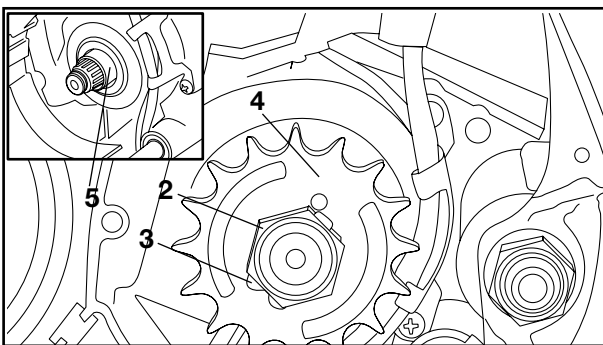

4. Remove:
  - Drive chain
  - Nut (Drive sprocket) ②
  - Lock washer ③
  - Drive sprocket ④
  - Spacer collar ⑤

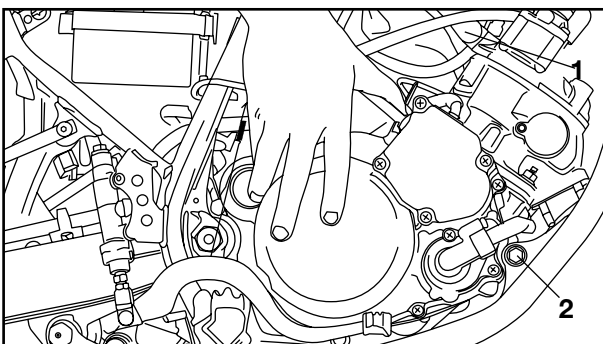

## ENGINE REMOVAL

1. Remove:
  - Bolts (Engine stay → Upper) ①
  - Bolts (Engine mount → Front) ②

## ENGINE REMOVAL/ ENGINE DISASSEMBLY

ENG

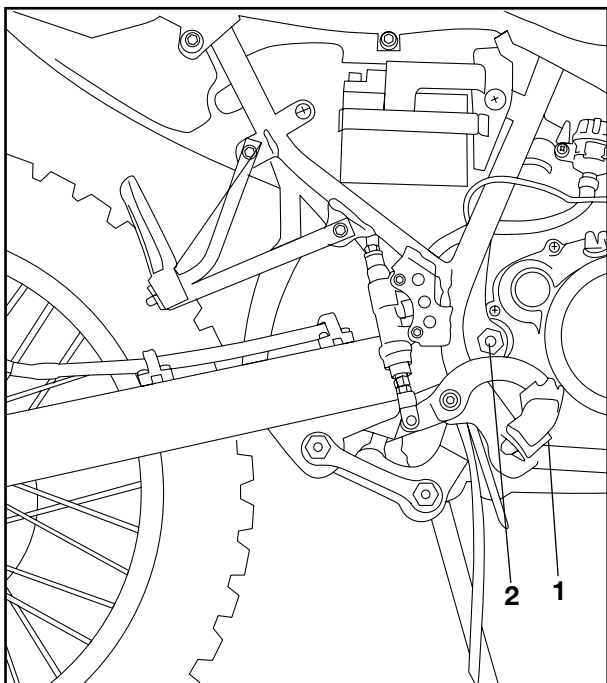

2. Remove:
  - Bolt (Engine mount → Rear lower)①
  - Pivot shaft ②

### NOTE:

The engine and swingarm are installed using the same pivot shaft. Therefore, take care so that the pivot shaft is pulled, not entirely, out, but for enough to set the engine free.

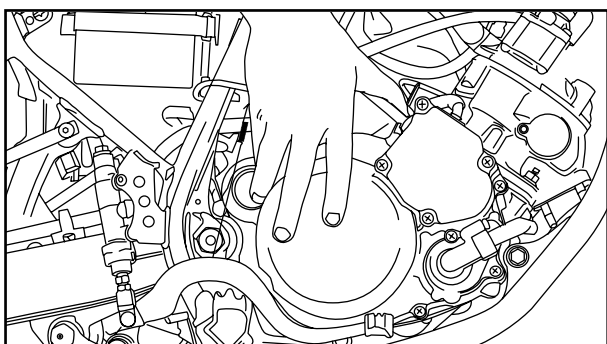

3. Remove:
  - Engine assembly (from right side)

## ENGINE DISASSEMBLY CYLINDER HEAD, CYLINDER AND PISTON

### NOTE:

With the engine mounted, the cylinder head, cylinder and piston can be maintained by removing the following parts.

- Side covers (Right and left)
- Seat
- Radiator cover
- Oil tank cover
- Fuel tank
- Radiator hose (inlet)
- Servomotor unit (Y.P.V.S.)
- Engine stay (Upper)
- Exhaust pipe

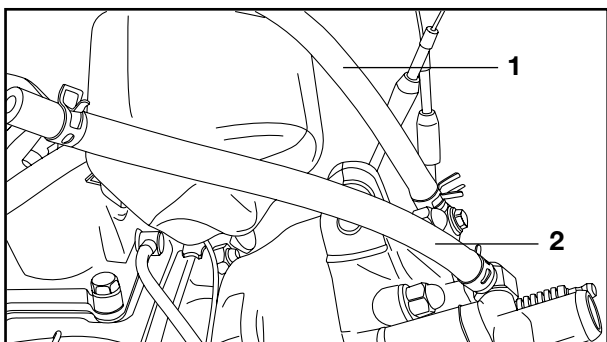

1. Remove:
  - Hoses (Inlet ① and Outlet ②)

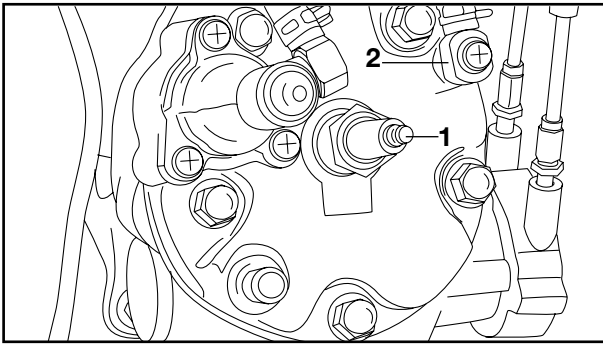

2. Remove:
- Spark plug ①
  - Thermo unit ②

**⚠ WARNING**

Handle the thermo unit with special care. Never subject it to strong or allow it to be dropped. In case of being dropped, it must be replaced.

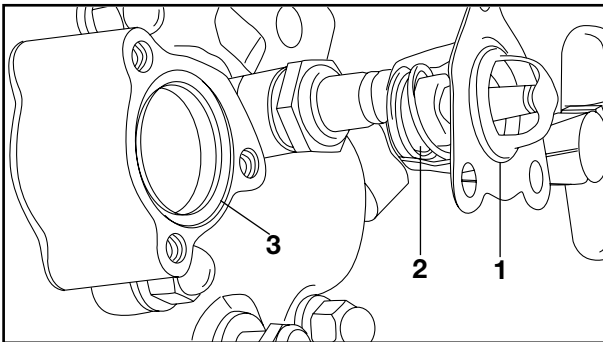

3. Remove:
- Cover (thermostatic valve)

4. Remove:
- Gasket ①
  - Thermostatic valve ②
  - O-ring ③

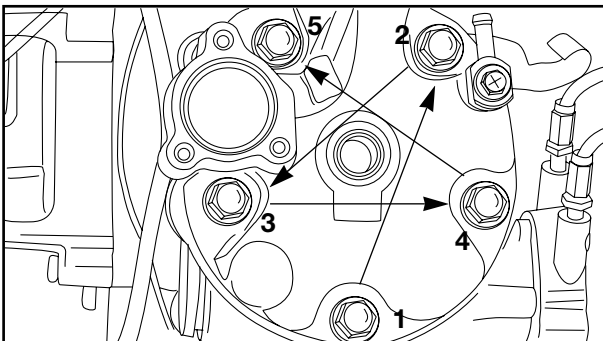

5. Remove:
- Cylinder head
  - Gasket (Cylinder head)

**NOTE:**

- Loosen the nuts starting with the highest numbered one.
- Loosen each nut 1/4 turn, and remove them after all nuts are loosened.

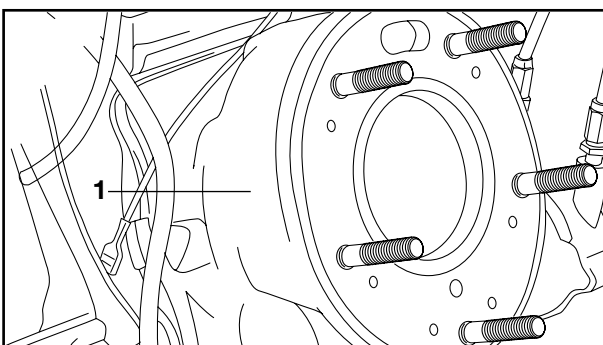

6. Remove:
- Clutch cable guide
  - Cylinder ①
  - Gasket (Cylinder)
  - Dowel pins

**NOTE:**

Loosen each nut 1/4 turn, and remove them after all nuts are loosened.

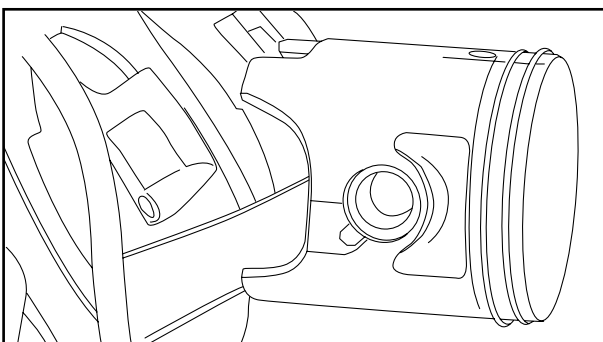

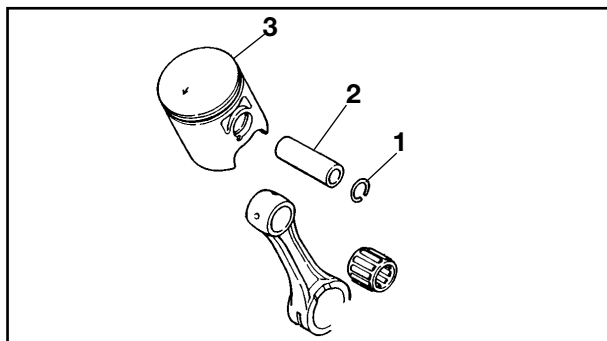

EAS00253

### REMOVING THE CYLINDER AND PISTON

1. Remove:

- piston pin clip ①
- piston pin ②
- piston ③

#### CAUTION

**Do not use a hammer to drive the piston pin out.**

#### NOTE:

- Before removing the piston pin clip, cover the crankcase opening with a clean rag to prevent the piston pin clip from falling into the crankcase.
- Before removing the piston pin, deburr the piston pin clip's groove and the piston's pin bore area. If both areas are deburred and the piston pin is still difficult to remove, remove it with the piston pin puller set.



**Piston pin puller set**  
90890-01304

2. Remove:

- top ring
- 2nd ring
- oil ring

#### NOTE:

When removing a piston ring, open the end gap with your fingers and lift the other side of the ring over the piston crown.

### CLUTCH, PRIMARY DRIVE GEAR AND BALANCER GEAR

#### NOTE:

With the engine mounted, the clutch, primary drive gear and balancer gear can be maintained by removing the following parts:

- Brake pedal
- Radiator hose (Outlet)
- Autolube pump cable and hoses
- Crankcase cover (Right)



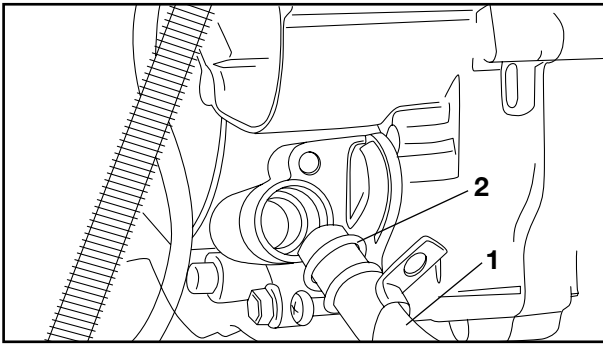

1. Remove:
- Water outlet pipe ①
  - O-Ring ②  
(from water outlet pipe)

- ① Right side
- ② Left side

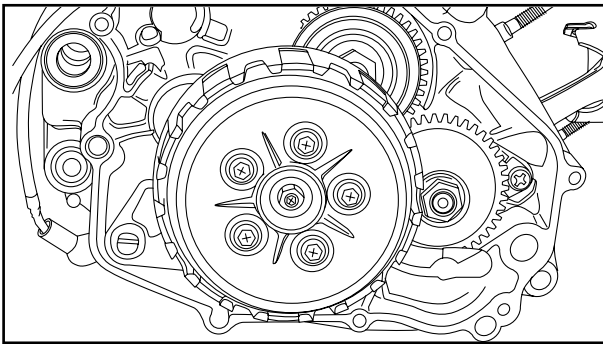

2. Remove:
- Crankcase cover (Right)
  - Dowel pins
  - Gasket (Crankcase cover)

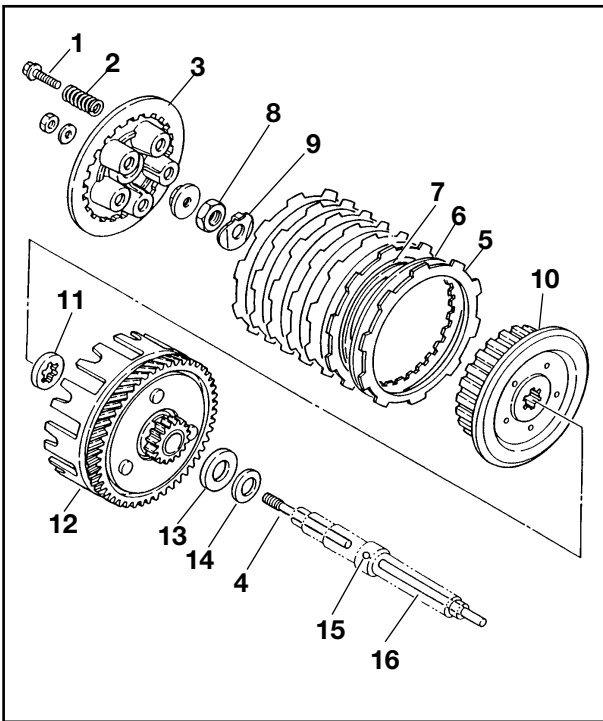

3. Remove:
- Bolts ①
  - Clutch springs ②
  - Pressure plate ③
  - Push rod #1 ④
  - Friction plates ⑤
  - Clutch plates ⑥
  - Clutch dumper ⑦
  - Nut (Clutch boss) ⑧
  - Lock washer ⑨
  - Clutch boss ⑩
  - Thrust washer ⑪
  - Clutch housing ⑫
  - Thrust plate ⑬
  - Conical spring washer ⑭
  - Boll ⑮
  - Push rod #2 ⑯

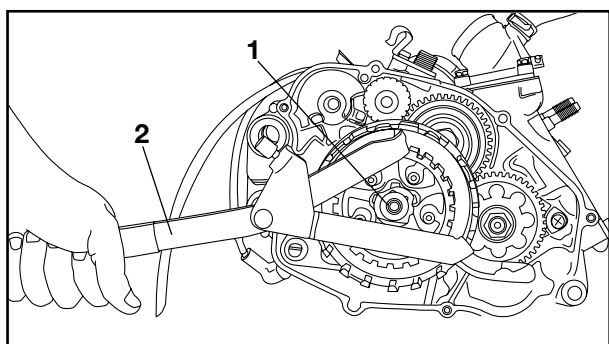

### NOTE:

- Before loosening the nut (Clutch boss) ① straighten the lock washer tab.
- Hold the clutch boss to loosen the nut (Clutch boss) by the universal Clutch holder ②



**Universal Clutch Holder**  
90890-04086

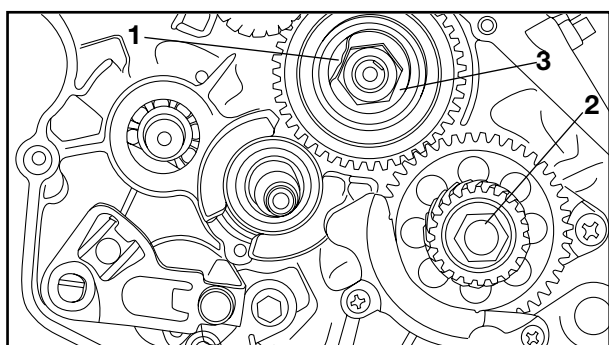

### 4. Straighten:

- Lock washer tab ①

### 5. Loosen:

- Nut (Primary drive gear) ②
- Nut (Balancer gear) ③

### NOTE:

Hold the magneto rotor to loosen the nut (primary drive gear) and nut (Balancer driven gear) by the universal rotor holder



**Universal Rotor Holder**  
90890-01235

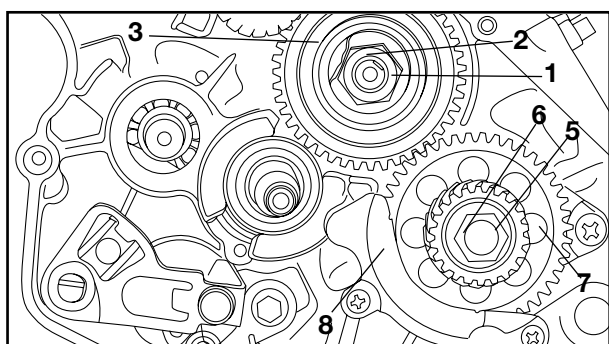

### 6. Remove:

- Nut (Balancer driven gear) ①
- Lock washer ②
- Driven gear (Balancer weight) ③
- Straight key
- Nut (Primary drive gear) ⑤
- Plain washer ⑥
- Primary drive gear ⑦
- Baffle plate ⑧

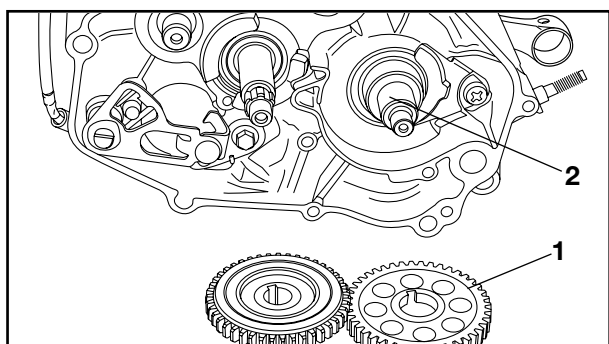

### 7. Remove:

- Drive gear (Balancer weight) ①
- Straight key ②



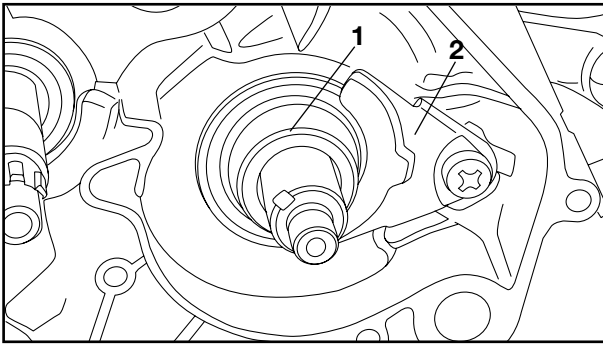

8. Remove:
- Spacer collar ①
  - Oil seal retainer ②

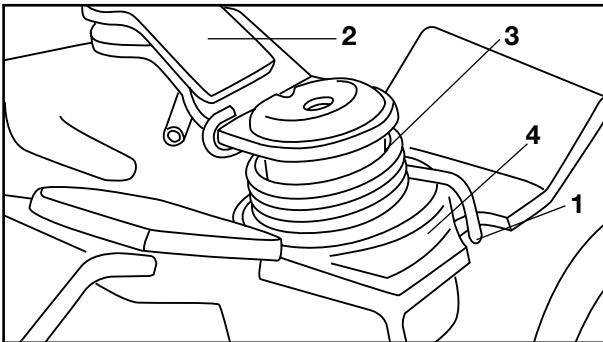

## CLUTCH PUSH LEVER

1. Unhook:
  - Return spring (Push lever) ①
2. Remove:
  - Push lever (Clutch) ②
  - Return spring ③
  - Washer ④

## SHIFT SHAFT AND STOPPER LEVER

### NOTE:

With the engine mounted, the shift shaft can be maintained by removing the following parts.

- Brake pedal
- Radiator hose (Outlet)
- Autolube pump cable and hoses
- Crankcase cover (Right)
- Clutch

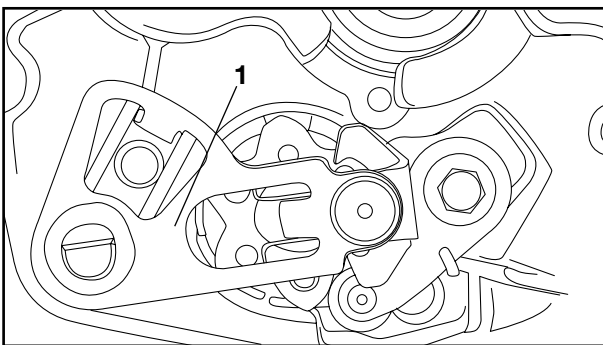

1. Remove:
  - Shift shaft ①

### CAUTION

**When removing the shift shaft, hold the guide bar (shift fork) 2 in place. Otherwise, the guide bar will come loose with the shift shaft, leaving the shift fork out of order in the crankcase.**

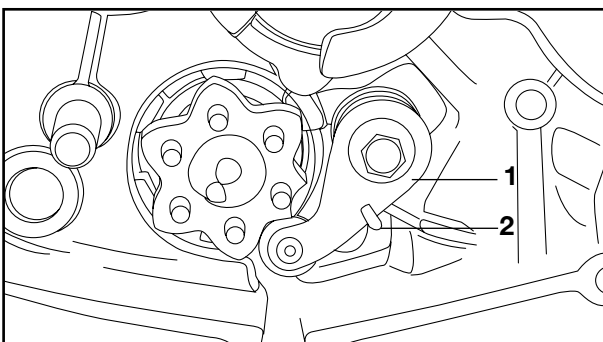

2. Remove:
  - Stopper lever ①
  - Return spring ②



## ROTOR

**NOTE:** \_\_\_\_\_

With the engine mounted, the rotor can be maintained by removing the following parts:

- Crankcase cover (Left).

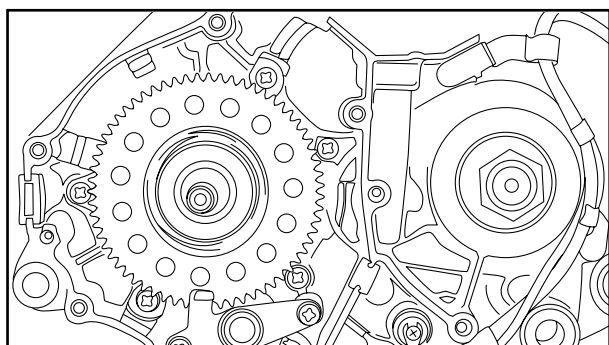

1. Remove:
  - Nut (Rotor)
  - Plain washer

**NOTE:** \_\_\_\_\_

Hold the rotor to loosen the nut (Rotor) by the Universal Rotor Holder



**Universal Rotor Holder**  
90890-01235

2. Remove:
  - Rotor
  - Woodruff key



**Rotor Puller**  
90890-01189

3. Disconnect:
  - Neutral switch lead
4. Remove:
  - Stator

## REED VALVE

**NOTE:** \_\_\_\_\_

With the engine mounted, the reed valve can be maintained by removing the following parts:

- Side covers (Right and Left)
- Seat
- Radiator cover
- Oil tank cover
- Fuel tank
- Carburetor

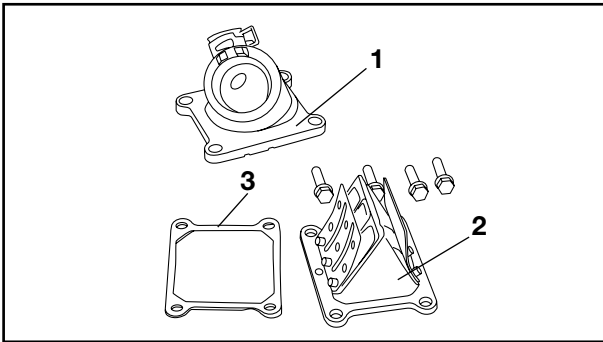

1. Remove:
- Carburetor joint ①
  - Reed valve assembly ②
  - Gasket ③

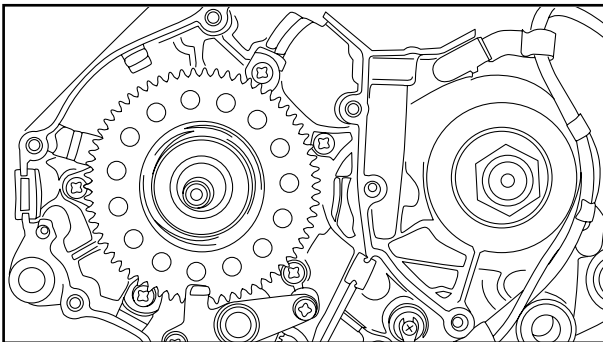

## CRANKCASE RIGHT

1. Remove:
- Crankcase (Right)

### NOTE:

- Loosen the bolts starting with the highest numbered one.
- Loosen each bolt 1/4 turn and remove them after all bolts are loosened.

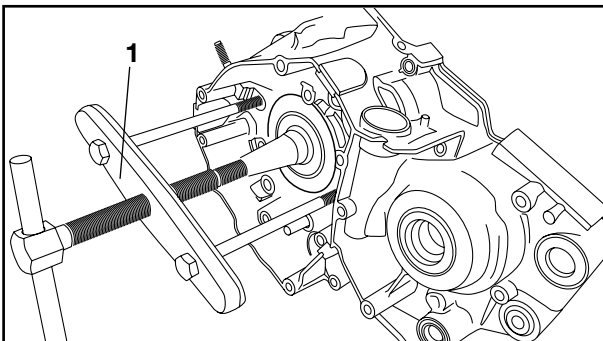

### Removal steps:

- Attach the Crankcase Separating Tool ①



**Crankcase Separating Tool:**  
90890-01135

### NOTE:

Fully tighten the tool holding bolts, but make sure the tool body is parallel with the case. If necessary, one screw may be backed out slightly to level tool body.

- As pressure is applied alternately tap on the front engine mounting boss, transmission shafts and shift cam. Then remove the crankcase (Right).

### NOTE:

Turn the shift cam ① to the position shown in the figure so that it doesn't contact the crankcase when separating the crankcase.

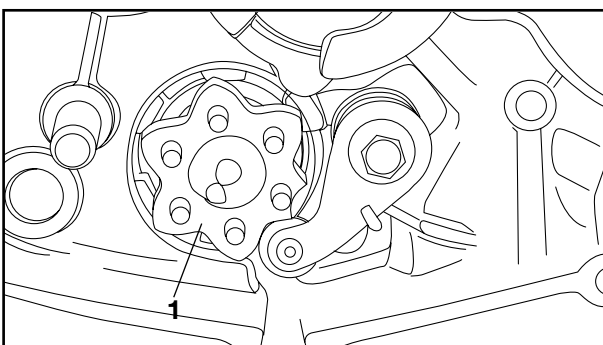



### CAUTION

- Use soft hammer to tap on the case half.
- Tap only on reinforced portions of case.
- Don't tap on gasket mating surface.
- Work slowly and carefully.
- Make sure the case halves separate evenly. If one end "hangs up", take pressure off the push screw, realign, and start over. If the cases don't separate, check for a remaining case screw or fitting.
- Don't force.

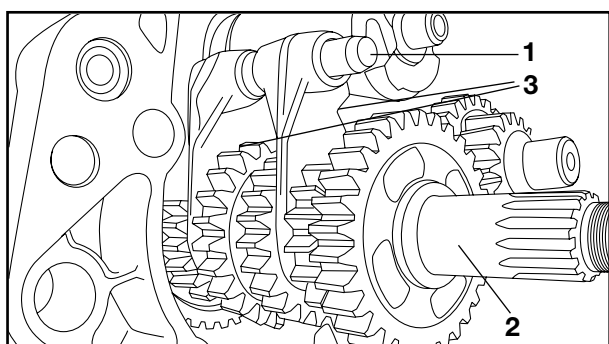
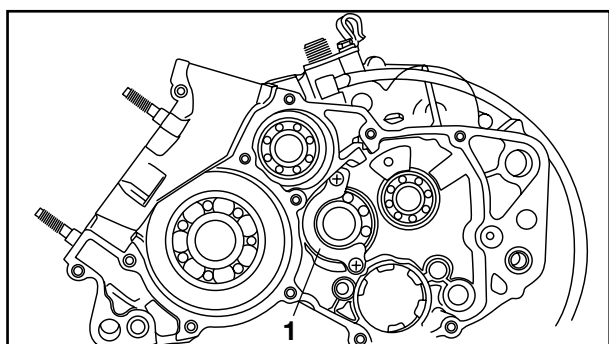
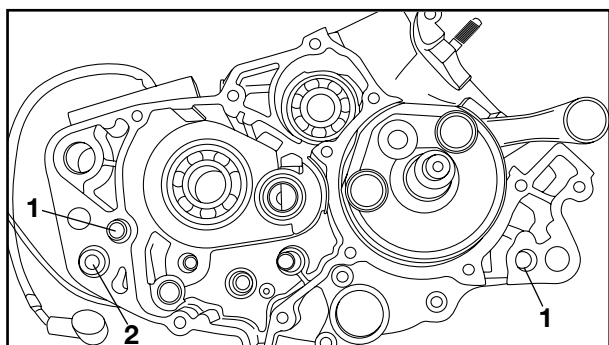

### 2. Remove:

- Dowel pins ①
- Damper collar ②

### 3. Remove:

- Bearing retainer ①

### SHIFTER, TRANSMISSION AND BALANCER WEIGHT

#### 1. Remove:

- Guide bars ①
- Shift cam ②
- Shift forks ③

#### NOTE:

Note the position of each part. Pay particular attention to the location and direction of shift forks.

#### 2. Remove:

- Transmission assembly  
Tap lightly on the transmission drive axle with a soft hammer.

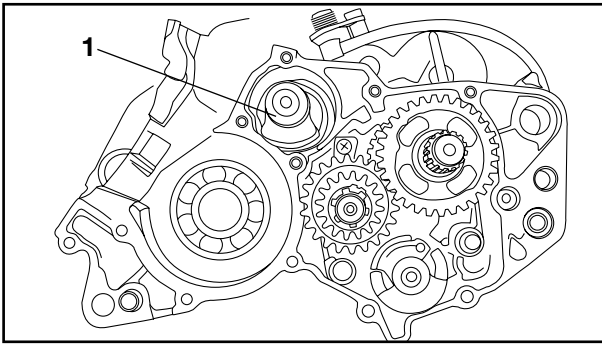

3. Remove:
- Balancer weight ①

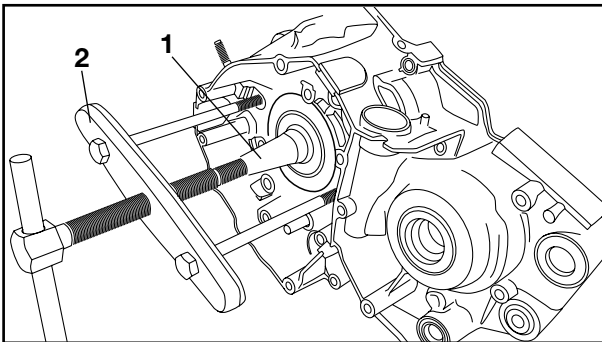

## CRANKSHAFT

1. Remove:
- Crankshaft ①

### NOTE:

- Remove the crankshaft with the Crankcase Separating Tool ②

- Fully tighten the tool holding bolts, but make sure the tool body is parallel with the case. If necessary, one screw may be backed out slightly to level tool body.



**Crankcase Separating Tool:**  
90890-01135

## POWER VALVE

### NOTE:

With the engine mounted, the power valve can be maintained by removing the following parts:

- Side covers
- Seat
- Radiator cover
- Cover (engine oil tank)
- Fuel tank
- Servomotor unit

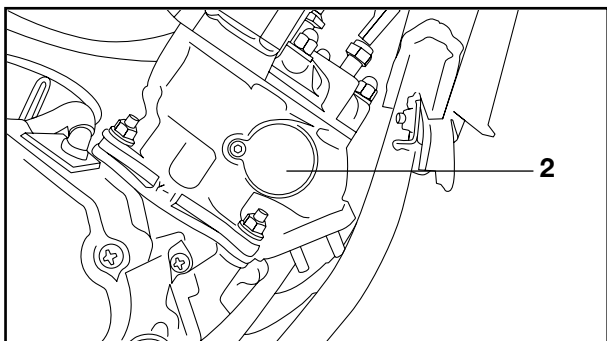

1. Remove:
  - Hose guide
  - Power valve holder (Right) ②

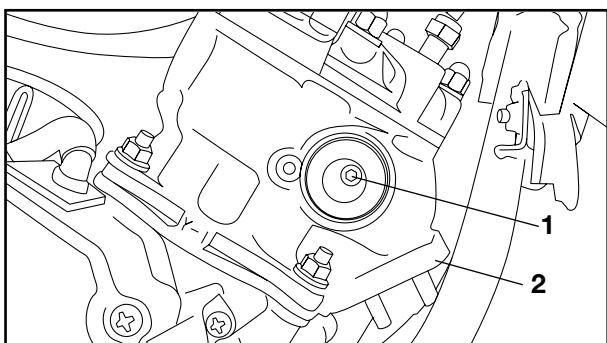

2. Remove:
  - Bolt (Power valve) ①

**NOTE:** \_\_\_\_\_

When loosening the power valve connecting bolt ①, lock the valve by inserting a wooden pice ② into the exhaust port.

\_\_\_\_\_

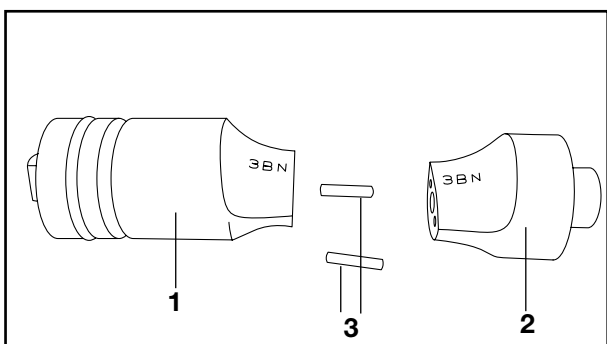

3. Remove:
  - Power valve (Right) ①
  - Power valve (Left) ②
  - Dowel pins ③
  - Holder (Power valve)
  - Gasket seal

## AUTOLUBE PUMP ASSEMBLY

**NOTE:** \_\_\_\_\_

With the engine mounted, the autolube pump assembly can be maintained by removing the following parts:

- Brake pedal
  - Radiator hose (Outlet)
  - Autolube pump cable and hoses
  - Kick crank
  - Crankcase cover (Right)
- \_\_\_\_\_

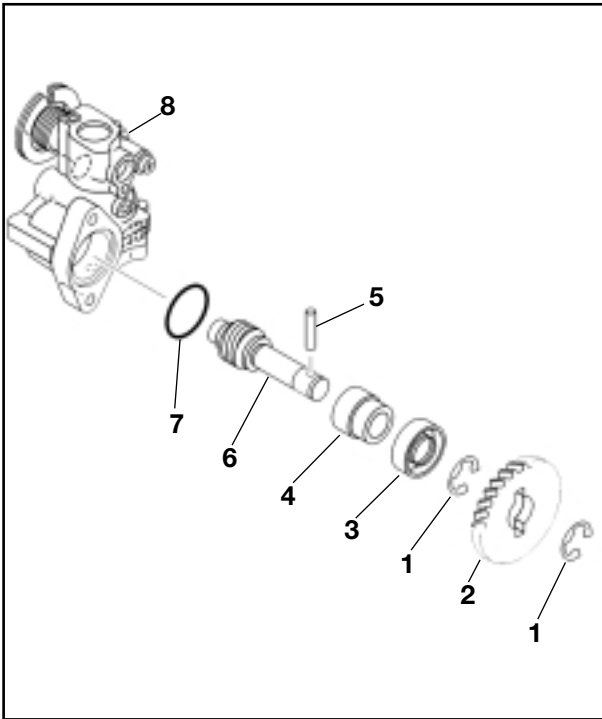

## 1. Remove:(ref. oilpump)

- ① Circlip
- ② Drive gear (autolube pump)
- ① Circlip
- ③ Oil seal
- ④ Collar
- ⑤ Pin
- ⑥ Drive shaft (autolube pump)
- ⑦ O-Ring
- ⑧ Autolube pump

EAS00227

## CHECKING THE CYLINDER HEAD

### 1. Eliminate:

- combustion chamber carbon deposits  
(with a rounded scraper)

### NOTE:

Do not use a sharp instrument to avoid damaging or scratching:

- spark plug bore threads
- valve seats

### 2. Check:

- cylinder head  
Damage/scratches → Replace.

### 3. Measure:

- cylinder head warpage  
Out of specification → Resurface the cylinder head.



**Maximum cylinder head warpage  
0.03 mm (0,0012 in)**

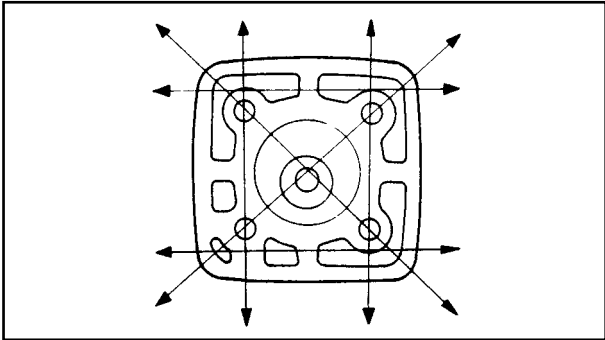

- a. Place a straightedge ① and a thickness gauge ② across the cylinder head.
- b. Measure the warpage.
- c. If the limit is exceeded, resurface the cylinder head as follows.
- d. Place a 400 ~ 600 grit wet sandpaper on the surface plate and resurface the cylinder head using a figure-eight sanding pattern.

**NOTE:** \_\_\_\_\_

To ensure an even surface, rotate the cylinder head several times.

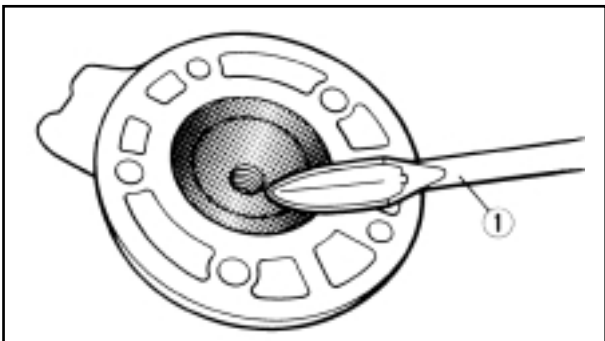

EAS00255

## CHECKING THE CYLINDER AND PISTON

1. Check:
  - piston wall
  - cylinder wall
 Vertical scratches → Rebore or replace the cylinder, and replace the piston and piston rings as a set.

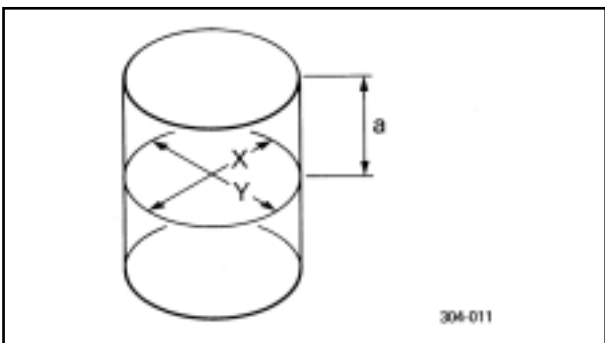

2. Measure:
  - piston-to-cylinder clearance



- a. Measure cylinder bore "C" with the cylinder bore gauge.

**NOTE:** \_\_\_\_\_

Measure cylinder bore "C" by taking side-to-side and front-to-back measurements of the cylinder. Then, find the average of the measurements.

**Cylinder bore gauge**  
56.00 ~ 56.02 mm (2.2047 ~ 2.2055 in)



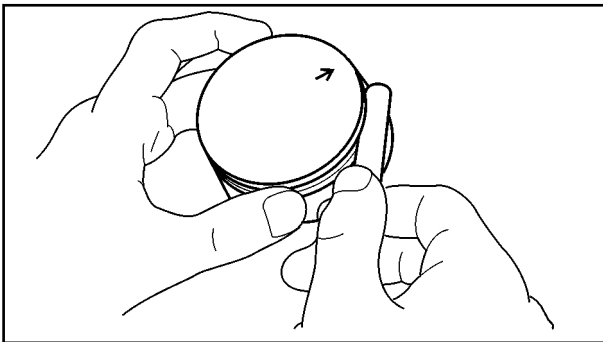
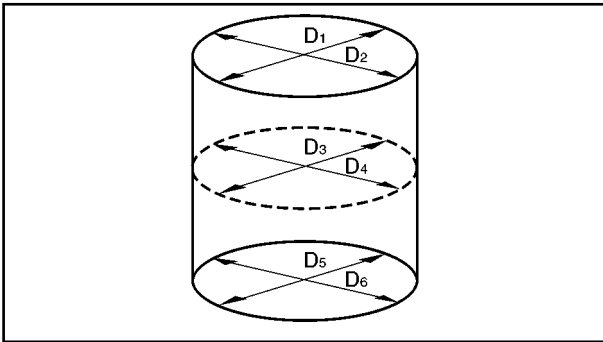

	Standard	Limit
Cylinder Bore "C"	56.00 ~ 56.02 mm (2.204 ~ 2.205 in)	
Taper "T"	—	0.05 mm (0.001968 in)
Out of round "R"	—	0.01 mm (0.00039 in)
C = maximum of D <sub>1</sub> ~ D <sub>2</sub> T = maximum of D <sub>1</sub> or D <sub>2</sub> - maximum of D <sub>5</sub> or D <sub>6</sub> R = maximum of D <sub>1</sub> , D <sub>3</sub> or D <sub>5</sub> - minimum of D <sub>2</sub> , D <sub>4</sub> or D <sub>6</sub>		

- b. If out of specification, rebore or replace the cylinder, and replace the piston and piston rings as a set.
- c. Measure piston skirt diameter "P" with the micrometer.

 **Micrometer**  
90890 - 03008

Piston size "P"	
Standard	56.34 ~ 56.40 mm (2.218 ~ 2.220 in)
Oversize ②	56.65 mm (2.23 in)
Oversize ④	56.90 mm (2.24 in)

- d. If out of specification, replace the piston and piston rings as a set.
- e. Calculate the piston-to-cylinder clearance with the following formula.

**Piston-to-cylinder clearance =  
Cylinder bore "C" -  
Piston skirt diameter "P"**

 **Piston-to-cylinder clearance**  
0.045 ~ 0.050 mm (0.0018 ~ 0.0020 in)  
**Limit: 0.1 mm (0.004 in)**

- f. If out of specification, rebore or replace the cylinder, and replace the piston and piston rings as a set.



EAS00264

**CHECKING THE PISTON RINGS**

- 1. Measure:
  - piston ring side clearance
 Out of specification ① → Replace the piston and piston rings as a set.

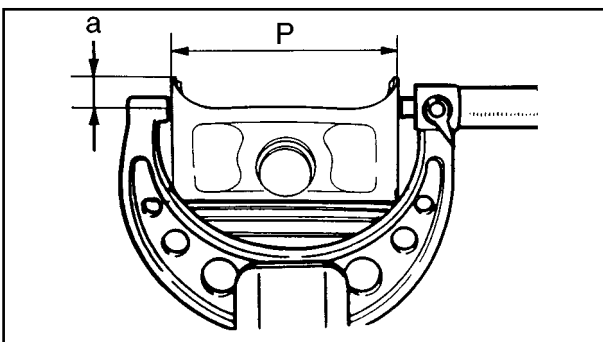

**NOTE:**

Before measuring the piston ring side clearance, eliminate any carbon deposits from the piston ring grooves and piston rings.

**Piston ring side clearance****Top ring**

0.02 ~ 0.060 mm (0.0008 ~ 0.0024 in)

**2nd ring**

0.035 ~ 0.070 mm (0.0014 ~ 0.0028 in)

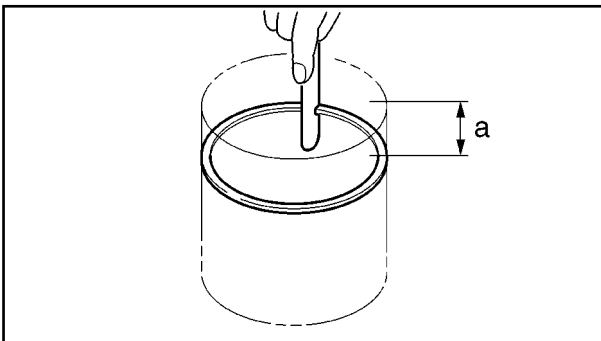

## 2. Install:

- piston ring (into the cylinder)

**NOTE:**

Level the piston ring into the cylinder with the piston crown.

## 3. Measure:

- piston ring end gap  
Out of specification → Replace the piston ring.

**NOTE:**

The oil ring expander spacer's end gap cannot be measured. If the oil ring rail's gap is excessive, replace all three piston rings.

**Piston ring end gap****Top ring**

0.3 ~ 0.45 mm  
(0.012 ~ 0.018 in)

**2nd ring**

0.30 ~ 0.45 mm  
(0.012 ~ 0.018 in)



**Piston ring oversize**

- Top and 2nd piston rings  
The size of the top and 2nd oversize piston rings is stamped on the top of each ring.

**Oversize  
25 mm  
Oversize  
50 mm**

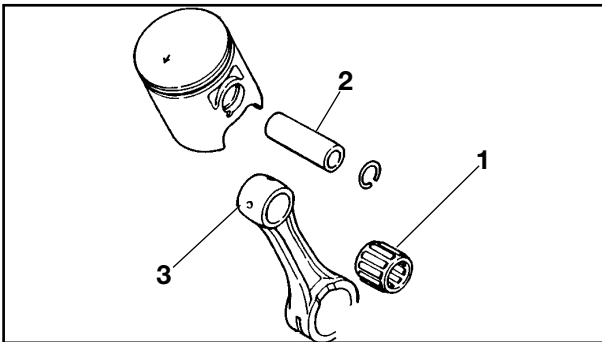

**PISTON PIN AND BEARING**

1. Lubricate:
  - Small end bearing ①
  - Piston pin ② (Lightly)
2. Install:
  - Small end bearing ①
  - Piston pin ② (into small end ③ of connecting rod)
3. Check:
  - Free play  
There should be no noticeable play. Free play exists → Inspect the connecting rod for wear/Replace the pin and/or connecting rod as required.
4. Install:
  - Piston pin (into piston pin hole)
5. Check:
  - Free play (when the piston pin is in place in the piston).  
There should be no noticeable play. Free play exists → Inspect the connecting rod for wear/Replace the pin and/or connecting rod as required.
6. Inspect:
  - Piston pin and bearing  
Signs of heat discoloration → Replace

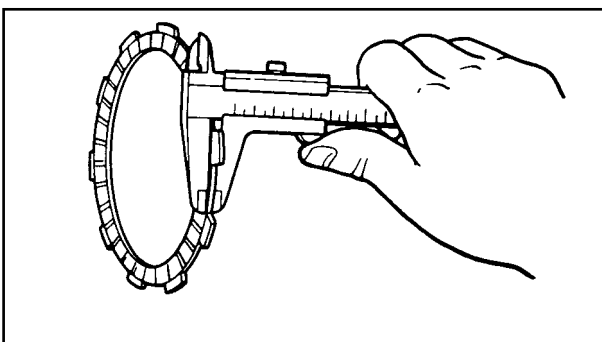
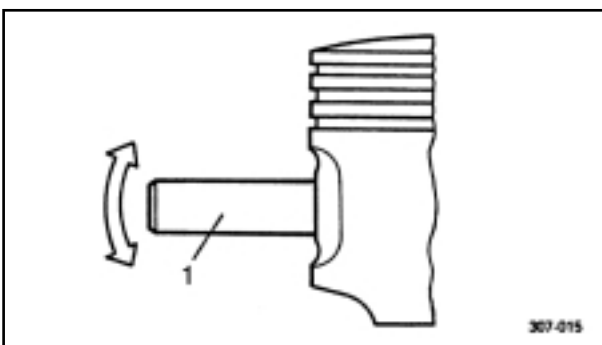
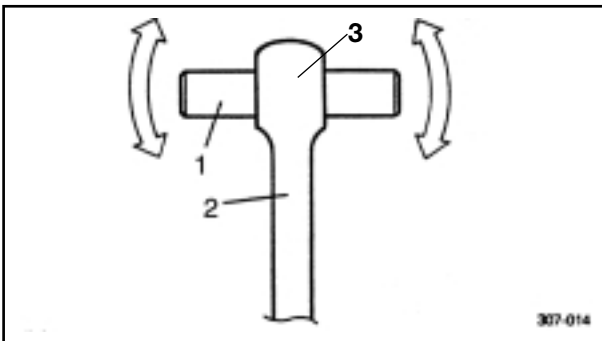

EAS00280

**CHECKING THE FRICTION PLATES**

The following procedure applies to all of the friction plates.

1. Check:
  - friction plate  
Damage/wear → Replace the friction plates as a set.



## 2. Measure:

- friction plate thickness  
Out of specification → Replace the friction plates as a set.

**NOTE:**

Measure the friction plate at four places.

**Friction plate thickness**

2.9 ~ 3.1 mm (0.11 ~ 0.12 in)

<Limit>: 2.7 mm

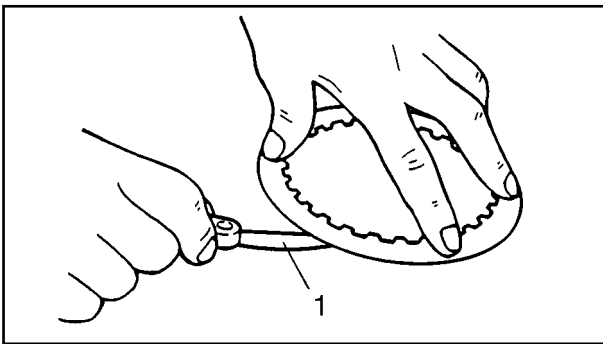

EAS00281

**CHECKING THE CLUTCH PLATES**

The following procedure applies to all of the clutch plates.

## 1. Check:

- clutch plate  
Damage → Replace the clutch plates as a set.

## 2. Measure:

- clutch plate warpage  
(with a surface plate and thickness gauge  
①)  
Out of specification → Replace the clutch plates as a set.

**Clutch plate warpage limit**

0.05 mm (0.001 in)

EAS00282

**CHECKING THE CLUTCH SPRINGS**

The following procedure applies to all of the clutch springs.

## 1. Check:

- clutch spring  
Damage → Replace the clutch springs as a set.

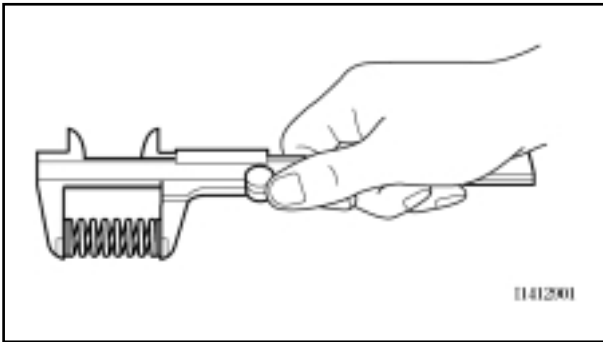

2. Measure:
  - clutch spring free length
  - Out of specification → Replace the clutch springs as a set.



**Clutch spring free length**  
34,5mm (1.36 in)

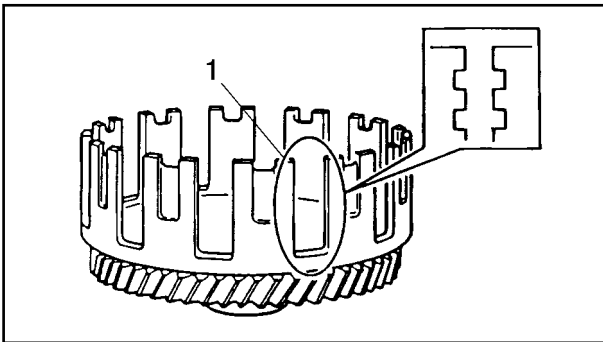

EAS00284

## CHECKING THE CLUTCH HOUSING

1. Check:
  - clutch housing dogs ①
  - Damage/pitting/wear → Deburr the clutch housing dogs or replace the clutch housing.

**NOTE:** \_\_\_\_\_

Pitting on the clutch housing dogs will cause erratic clutch operation.

2. Check:
  - bearing
  - Damage/wear → Replace the bearing and clutch housing.

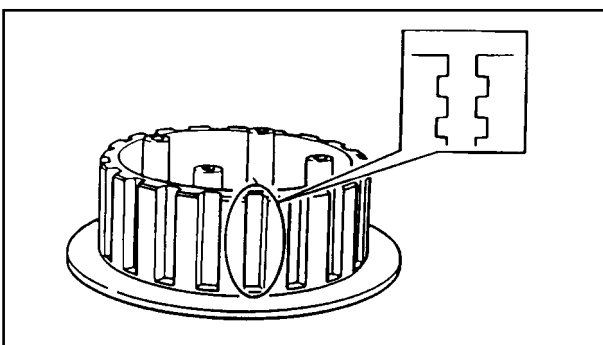

EAS00285

## CHECKING THE CLUTCH BOSS

1. Check:
  - clutch boss splines
  - Damage/pitting/wear → Replace the clutch boss.

**NOTE:** \_\_\_\_\_

Pitting on the clutch boss splines will cause erratic clutch operation.

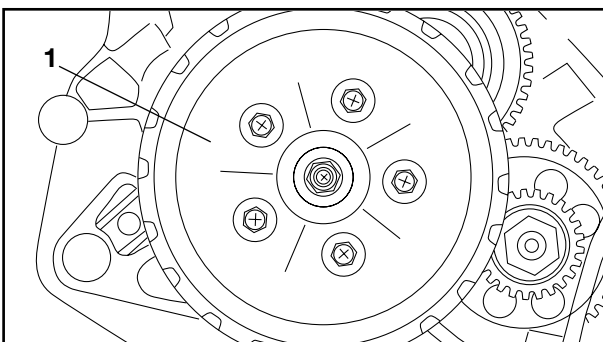

EAS00286

## CHECKING THE PRESSURE PLATE

1. Check:
  - pressure plate ①
  - Cracks/damage → Replace.
  - bearing
  - Damage/wear → Replace.

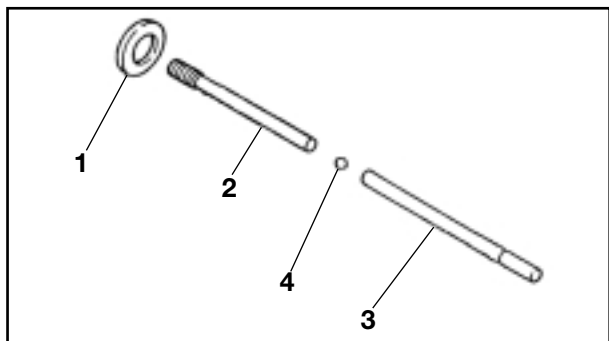

EAS00288

**CHECKING THE CLUTCH PUSH RODS**

## 1. Check:

- O-ring ①
- short clutch push rod ②
- long clutch push rod ③
- ball ④

Cracks/damage/wear → Replace the defective part(s).

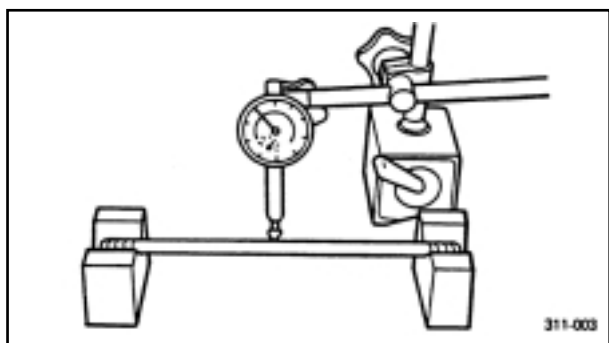

## 2. Measure:

- long clutch push rod bending limit  
Out of specification → Replace the long clutch push rod.



**Long clutch push rod bending limit  
0.15 mm (0.0059 in)**

EAS00292

**CHECKING THE PRIMARY DRIVE**

## 1. Check:

- primary drive gear
- primary driven gear  
Damage/wear → Replace the primary drive and primary driven gears as a set.  
Excessive noise during operation → Replace the primary drive and primary driven gears as a set.

## 2. Check:

- primary-drive-gear-to-primary-driven-gear free play  
Free play exists → Replace the primary drive and primary driven gears as a set.

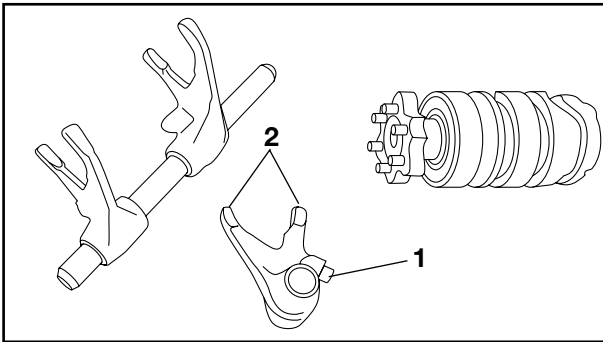

EAS00421

**CHECKING THE SHIFT FORKS**

The following procedure applies to all of the shift forks.

## 1. Check:

- shift fork cam follower ①
- shift fork pawl ②

Bends/damage/scoring/wear → Replace the shift fork.

## 2. Check:

- shift fork guide bar

Roll the shift fork guide bar on a flat surface.  
Bends → Replace.

**⚠ WARNING**

**Do not attempt to straighten a bent shift fork guide bar.**

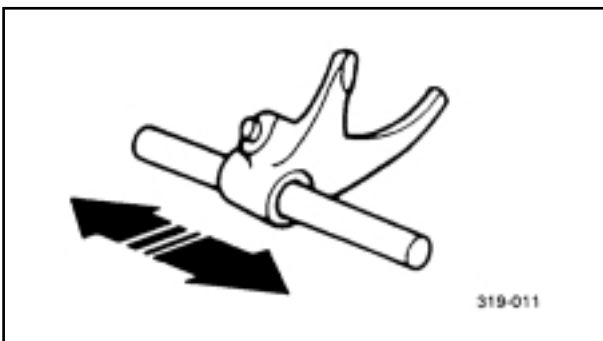
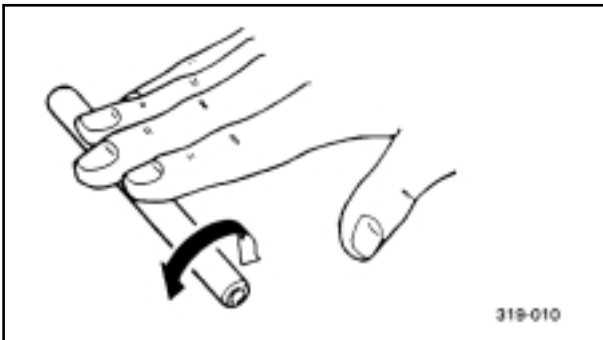

## 3. Check:

- shift fork movement

(along the shift fork guide bar)

Rough movement → Replace the shift forks and shift fork guide bar as a set.

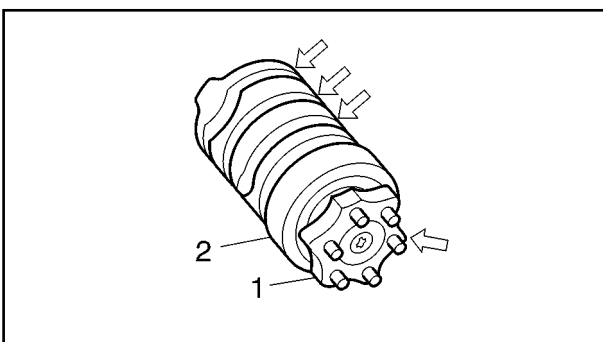

EAS00422

**CHECKING THE SHIFT DRUM ASSEMBLY**

## 1. Check:

- shift drum grooves

Damage/scratches/wear → Replace the shift drum assembly.

- shift drum segment ①

Damage/wear → Replace the shift drum assembly.

- shift drum bearing ②

Damage/pitting → Replace the shift drum assembly.



EAS00423

**CHECKING THE TRANSMISSION**

## 1. Measure:

- main axle runout  
(with a centering device and dial gauge ①)  
Out of specification → Replace the main axle.



**Main axle runout limit**  
**0.08 mm (0.0031 in)**

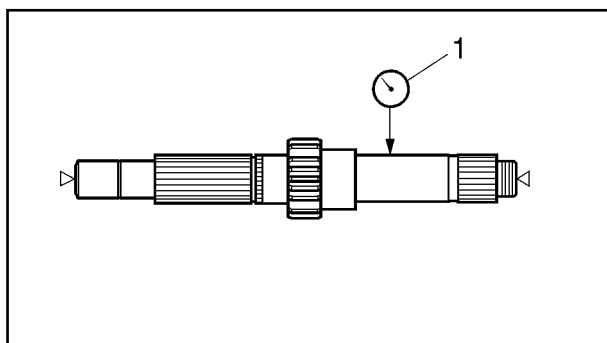

## 2. Measure:

- drive axle runout  
(with a centering device and dial gauge ①)  
Out of specification → Replace the drive axle.



**Drive axle runout limit**  
**0.08 mm (0.0031 in)**

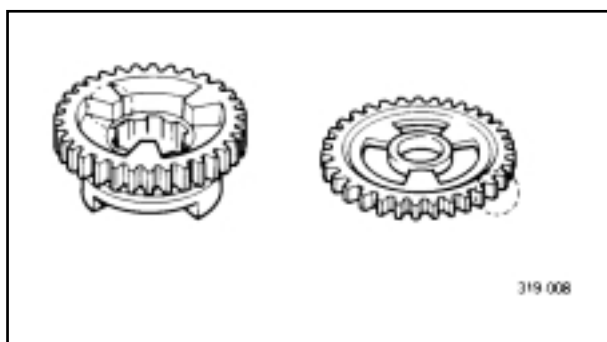

## 3. Check:

- transmission gears  
Blue discoloration/pitting/wear → Replace the defective gear(s).
- transmission gear dogs  
Cracks/damage/rounded edges → Replace the defective gear(s).

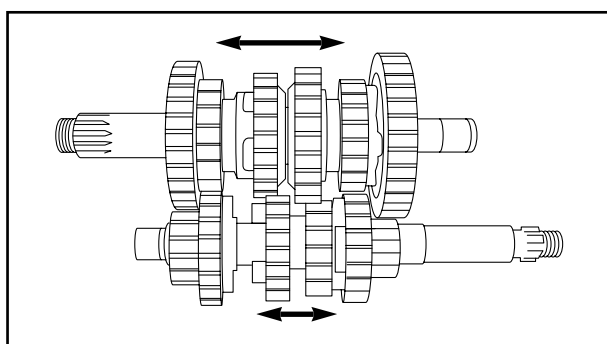

## 4. Check:

- transmission gear engagement  
(each pinion gear to its respective wheel gear)  
Incorrect → Reassemble the transmission axle assemblies.

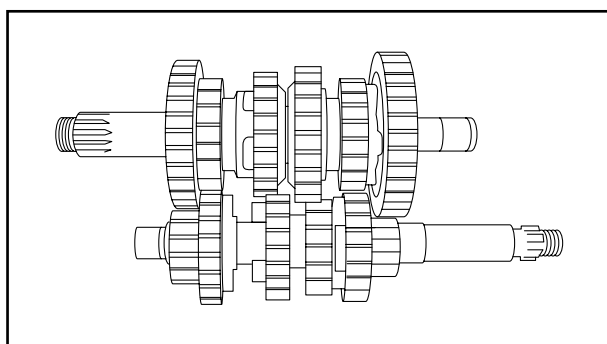

## 5. Check:

- transmission gear movement  
Rough movement → Replace the defective part(s).

## 6. Check:

- circlips  
Bends/damage/looseness → Replace.



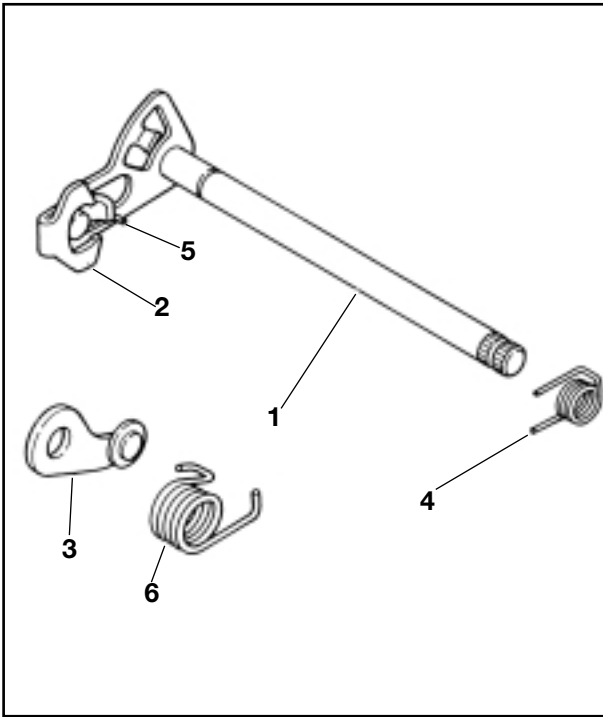

EAS00328

## CHECKING THE SHIFT SHAFT

1. Check:
  - shift shaft ①
  - shift pawls ②
 Bends/damage/wear → Replace.
2. Check:
  - stopper lever ③
 Roller turns roughly → Replace  
 Bend/damage → Replace
3. Check:
  - Return spring (shift shaft) ④
  - Return spring (Shift pawls) ⑤
  - Return spring (Stopper lever) ⑥
 Wear/damage → Replace.

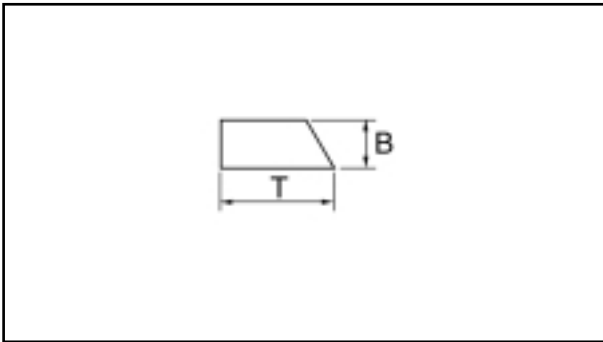

EAS00394

## CHECKING THE CRANKSHAFT AND CONNECTING ROD

1. Measure:
  - crankshaft runout
 Out of specification → Replace the crankshaft, bearing or both.

**NOTE:** \_\_\_\_\_

Turn the crankshaft slowly.



**Maximum crankshaft runout**  
**0.03 mm (0.0012 in)**

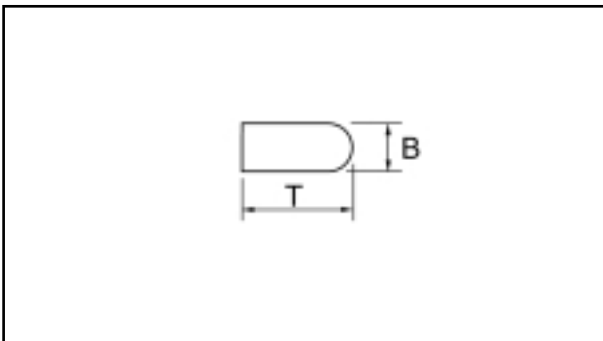

2. Measure:
  - big end side clearance
 Out of specification → Replace the big end bearing, crankshaft pin, or connecting rod.



**Big end side clearance**  
**0.2~0.7mm (0.0079~0.0276in)**



3. Measure:
  - crankshaft width  
Out of specification → Replace the crankshaft.



**Crankshaft width**  
57.9~57.95 mm (2.279~2.281 in)

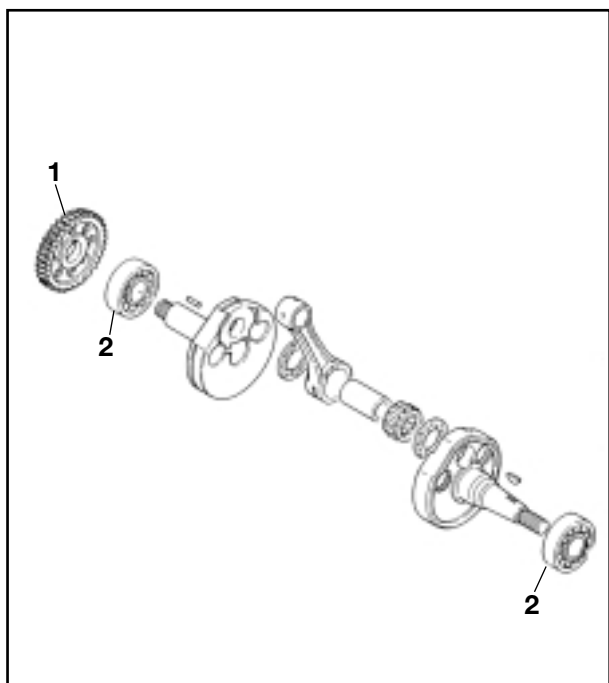

4. Check:
  - crankshaft sprocket ①  
Damage/wear → Replace the crankshaft.
  - bearing ②  
Cracks/damage/wear → Replace the crankshaft.

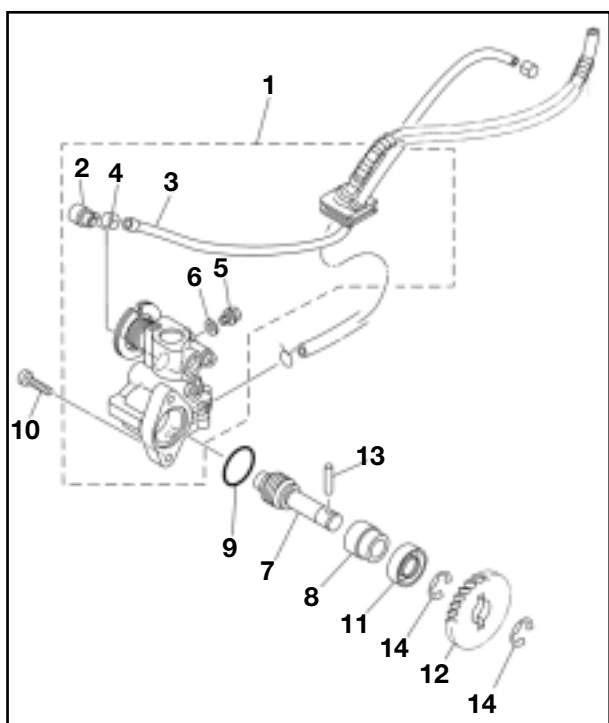

### AUTOLUBE PUMP

Wear or an internal malfunction may cause pump output to vary from the factory settings. This situation is, however extremely dangerous. If improper output is suspected, inspect the following:

1. Inspect:
  - Delivery line  
Obstructions → Blow out.
  - Pump body seal/crankcase cover seal  
Wear/damage → Replace.
2. Inspect:
  - Allowing air  
Air exists → Air bleed.  
Refer to the "AUTOLUBE PUMP AIR BLEEDING" section in chapter 3.



3. Check:
- Pump output.  
Out of specification → Adjust.



**Minimum output/200 stroke:**  
0.38 ~ 0.50cm<sup>3</sup> (0.02 ~ 0.03cu.in)  
**Maximum output/200stroke:**  
4.65 ~ 5.15cm<sup>3</sup> (0.28 ~ 0.31cu.in)

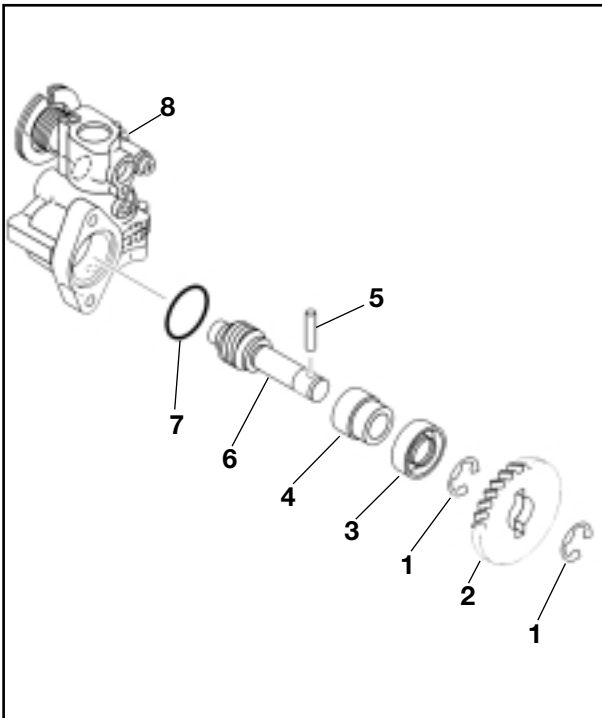

4. Check:
- Drive gear (Autolube pump) ②
  - Drive shaft (Autolube pump) ⑥
  - Pivot collar (Drive shaft) ④  
Wear/damage → Replace.

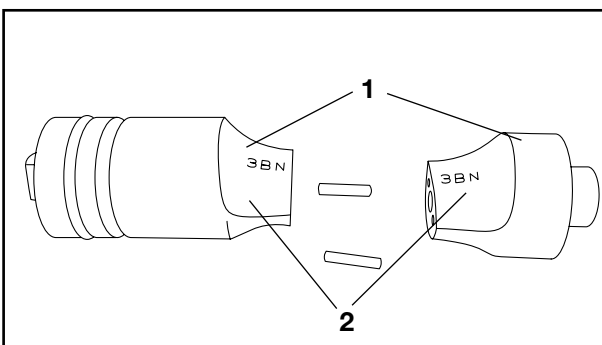

### POWER VALVE

1. Eliminate:
- Score marks and lacquer deposits.
  - Carbon deposits.  
(from power valve ①, specially in cleaning groove ② surface, and its contact surface of cylinder block).

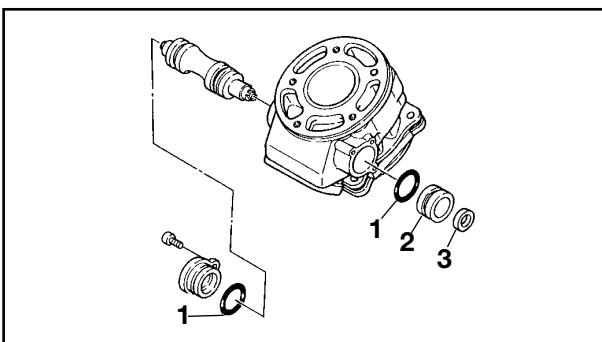

2. Check:
- O-rings ①
  - Bushes ②
  - Gasket seals ③  
Wear/damage → Replace

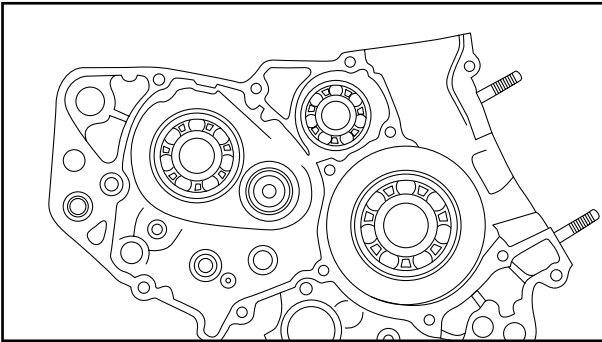
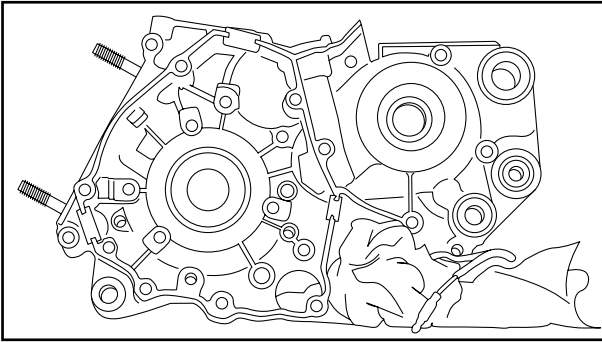

EAS00399

**CHECKING THE CRANKCASE**

1. Thoroughly wash the crankcase halves in a mild solvent.
2. Thoroughly clean all the gasket surfaces and crankcase mating surfaces.
3. Check:
  - crankcase  
Cracks/damage → Replace.
  - oil delivery passages  
Obstruction → Blow out with compressed air.



## AUTOLUBE PUMP

- |                  |                      |
|------------------|----------------------|
| ① Autolube pump  | ⑧ Collar             |
| ② End cap        | ⑨ O-Ring             |
| ③ Hose           | ⑩ Screw              |
| ④ Clip           | ⑪ Oil seal           |
| ⑤ Adjusting bolt | ⑫ Autolube pump gear |
| ⑥ Washer         | ⑬ Pin                |
| ⑦ Drive shaft    | ⑭ Circlip            |

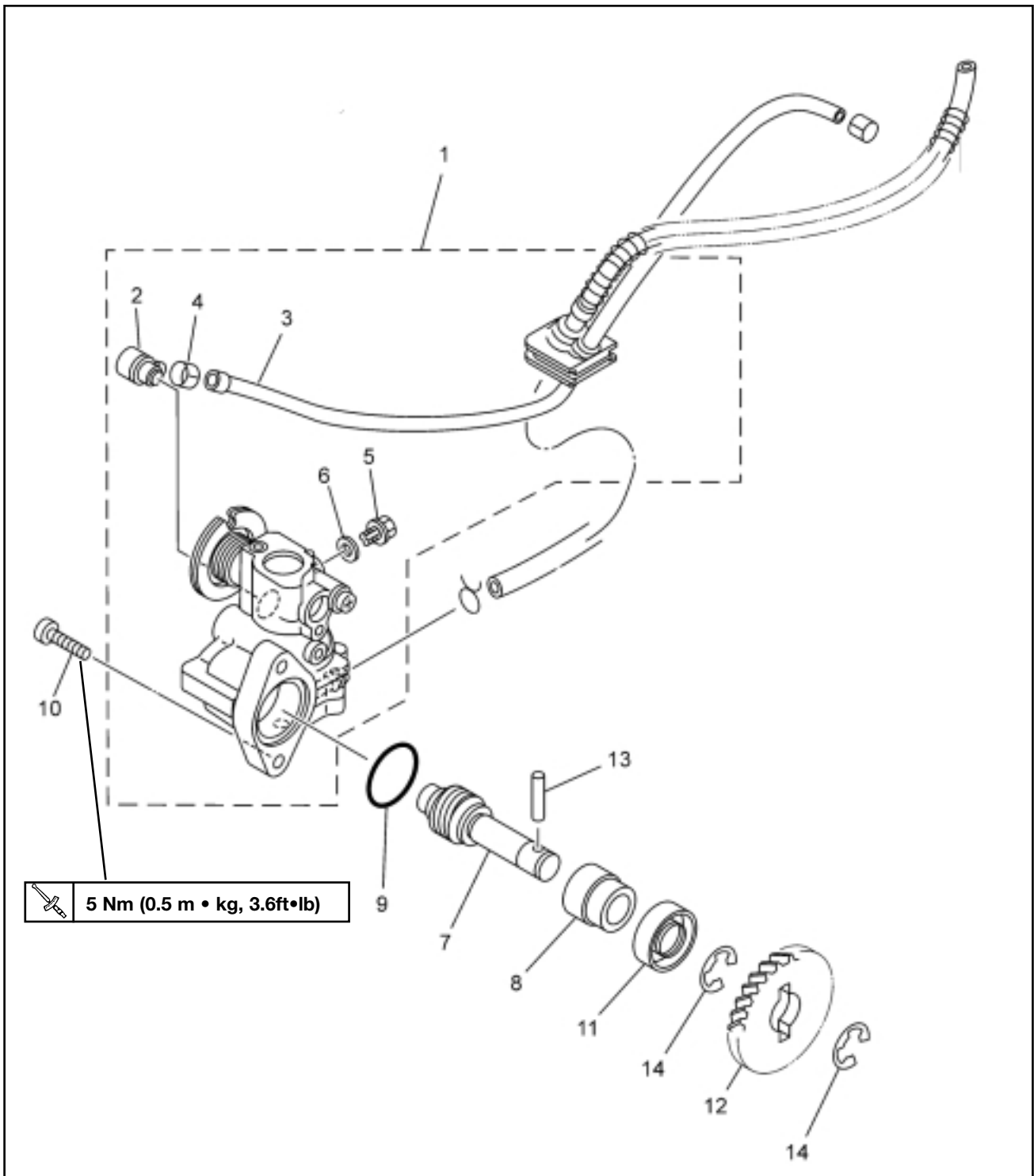

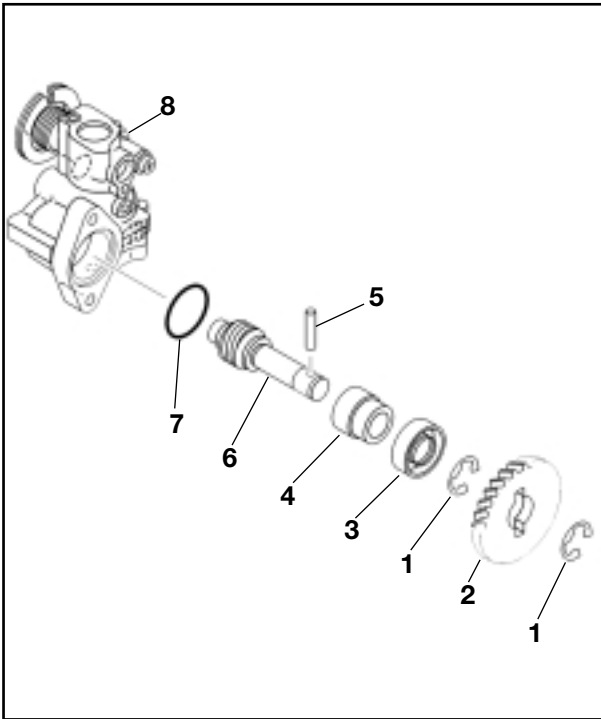

## AUTOLUBE PUMP

1. Lubricate:
  - Oil seal lips ③



**Lightweight Lithium-soap base grease**

2. Install:
  - Drive shaft (autolube pump) ⑥
  - Circlip ①
  - Pin ⑤
  - Drive gear (autolube pump) ②
  - Circlip ①
  - O-ring ⑦
  - Autolube pump ⑧



**Screw (Autolube pump):  
5 Nm (0.5m•kg; 3.6ft•lb)**

### **⚠ WARNING**

- Always use a new circlip
- Always use a new O-ring



## POWER VALVE

- ① Power valve
- ② Power valve holder (right)
- ③ O-ring
- ④ Power valve holder (left)
- ⑤ Gasket seal
- ⑥ Pulley housing
- ⑦ Pulley
- ⑧ Pulley cover
- ⑨ Y.P.V.S. Cable

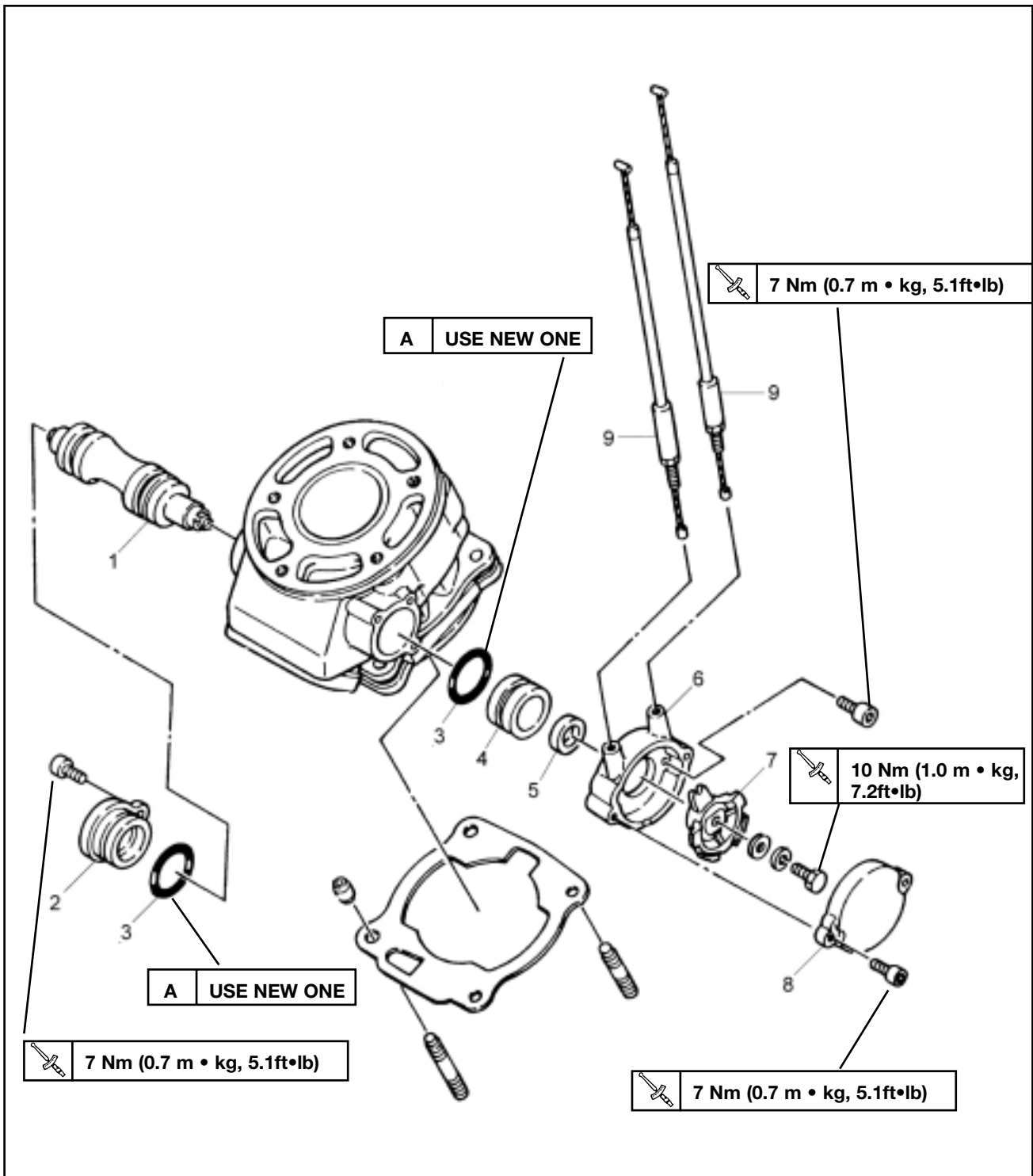

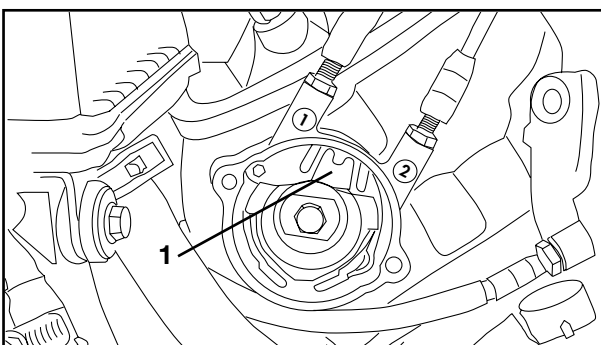
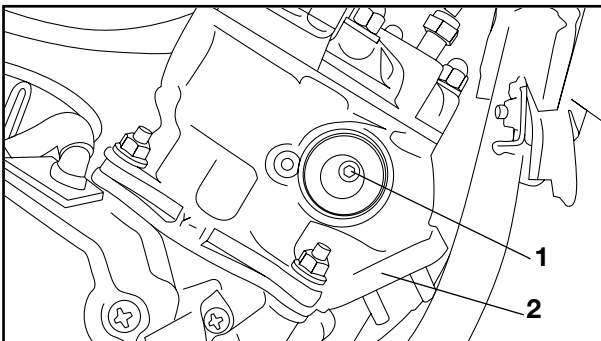
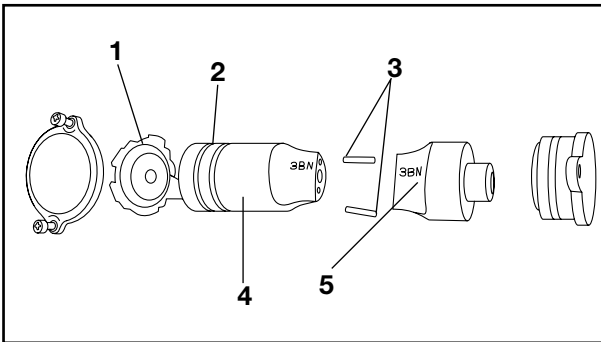
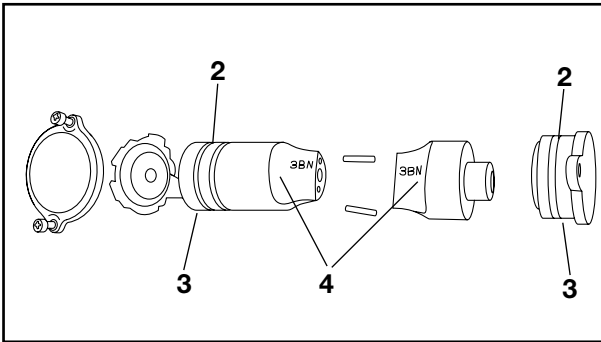

## POWER VALVE

- Lubricate:
  - Power valve connecting rod ①

	<b>Molybdenum Disulfide Grease</b>
--	------------------------------------

- O-rings ②
- Gasket seal ③
- Bushes (Power valve shaft contact surface)
- Power valve surface ④

	<b>Lightweight Lithium-soap base grease</b>
--	---

- Install:
  - Power valve holder (Left) ①
  - Gasket seal ② (to left power valve)
  - Dowel pins ③
  - Power valve (Left ④ and right ⑤) (to cylinder block)
  - Bolt (Power valve)

- Tighten:
  - Bolt (Power valve) ①

	<b>Bolt (Power Valve): 7 Nm (0.7 m•kg; 5.1 ft•lb)</b>
--	---

**NOTE:** \_\_\_\_\_  
 When tightening the power valve connecting bolt ①, lock the valve by inserting a wooden pice ② into the exhaust port.

- Install:
  - Power valve holder ①

	<b>Bolt (Power Valve Holder): 7 Nm (0.7 m•kg; 5.1 ft•lb)</b>
--	--

- Check:
  - Power valve operation  
 Unsmooth operation → Repair.





### CRANKSHAFT/PISTON/BALANCER

- |                   |                     |                   |
|-------------------|---------------------|-------------------|
| ① Balancer gear   | ⑨ Bearing           | ⑰ Thrust bearing  |
| ② Bearing         | ⑩ Piston ring set   | ⑱ Connecting rod  |
| ③ Straight key    | ⑪ Piston            | ⑲ Crank pin       |
| ④ Balancer weight | ⑫ Piston pin        | ⑳ Big end bearing |
| ⑤ Bearing         | ⑬ Piston pin clip   | ㉑ Crank (Left)    |
| ⑥ Drive gear      | ⑭ Small end bearing | ㉒ Wodruff key     |
| ⑦ Oil seal        | ⑮ Straight key      | ㉓ Bearing         |
| ⑧ Collar          | ⑯ Crank (Right)     | ㉔ Oil seal        |

<b>A</b>	<b>PISTON TO CYLINDER CLEARANCE:</b> 0.045~0.050 mm(0.0018~0.0020in)
<b>B</b>	<b>EN GAP (INSTALLED):</b> Top ring 0.30~0.45mm(0.012~0.018in) 2 <sup>nd</sup> ring 0.30~0.45mm(0.012~0.018in)

<b>C</b>	<b>CRANKSHAFT</b>
Width	57.90~57.95mm (2.279~2.271in)
Max Runout	0.03mm (0.012in)
Big end side clearance	0.2~0.7mm(0.0079~0.0276in)
Big end radial clearance	0.026~0.040mm(0in)

#### D BALANCER GEAR INSTALLATION

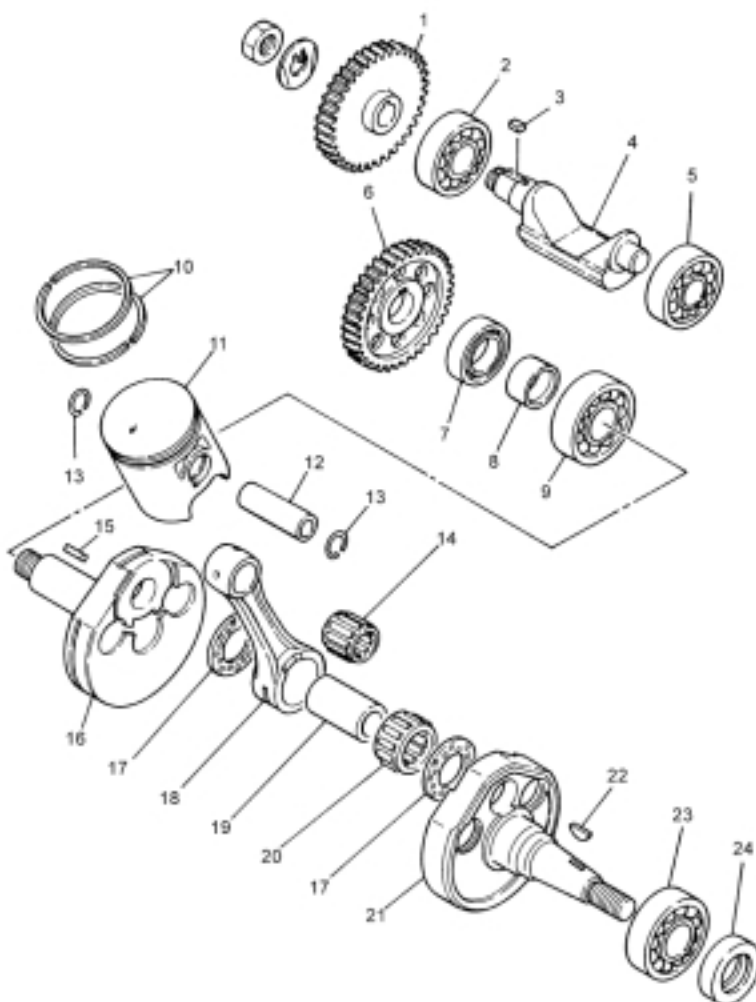
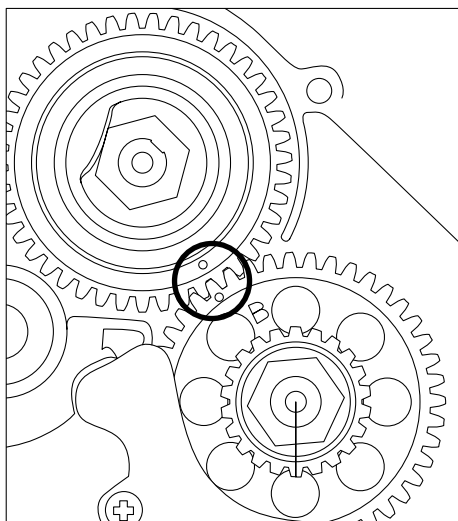



## TRANSMISSION

- |                        |                       |                  |
|------------------------|-----------------------|------------------|
| ① Main axle            | ⑨ Cylindrical bearing | ⑲ Special washer |
| ② 2nd pignion gear     | ⑩ Drive axle          | ⑳ Oil seal       |
| ③ 3rd 4th pignion gear | ⑪ 1st wheel gear      | ㉑ Drive sprocket |
| ④ 5th pignion gear     | ⑫ 2nd wheel gear      | ㉒ Lock washer    |
| ⑤ 6th pignion gear     | ⑬ 3rd wheel gear      |                  |
| ⑥ Plain washer         | ⑭ 4th wheel gear      |                  |
| ⑦ Circlip              | ⑮ 5th wheel gear      |                  |
| ⑧ Bearing              | ⑯ 6th wheel gear      |                  |

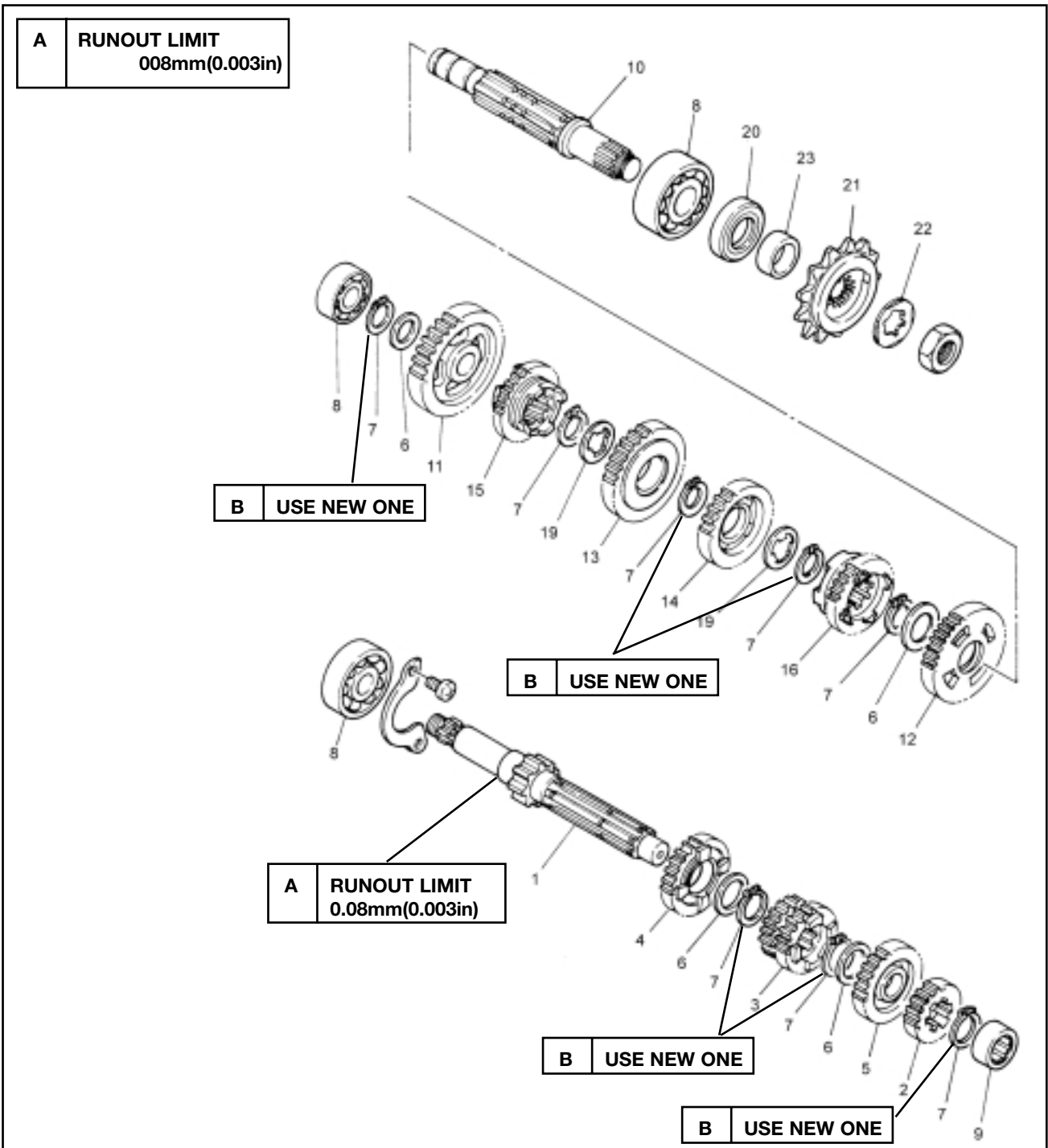



## SHIFTER

- ① Shift cam
- ② Stopper lever
- ③ Return spring
- ④ Securing bolt
- ⑤ Shift fork #1
- ⑥ Shift fork #2
- ⑦ Shift fork #3
- ⑧ Shift fork #1
- ⑨ Shift fork #2

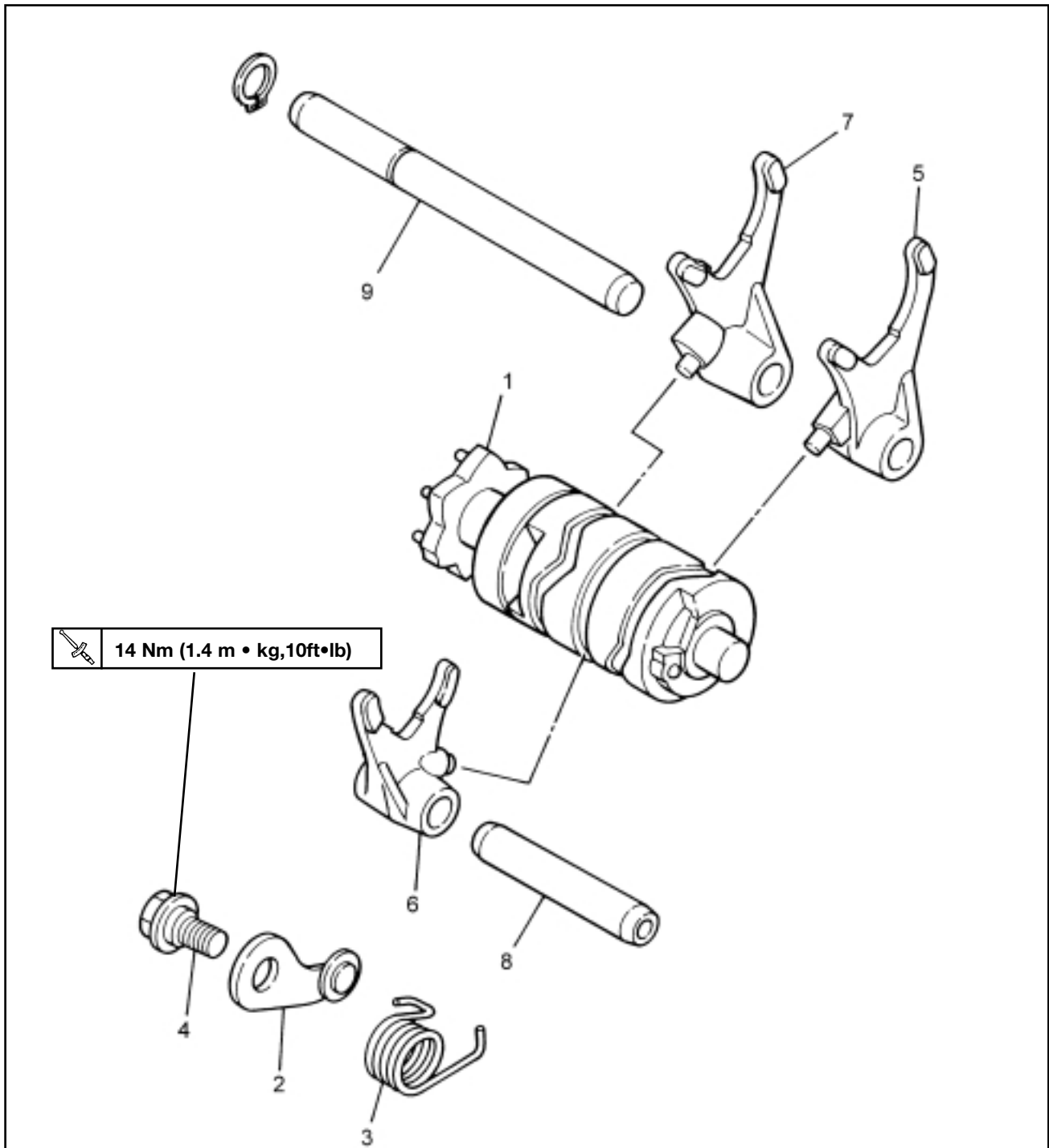

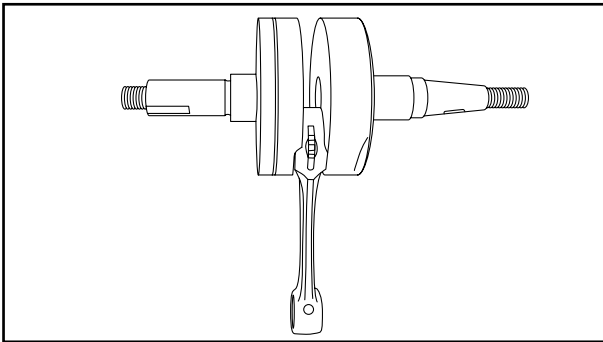

EAS00408

## INSTALLING THE CRANKSHAFT

1. Install:
  - crankshaft assembly

### NOTE:

- Install the crankshaft assembly with the crankshaft installer pot, crankshaft installer bolt, adapter (M12) and spacer.



**Crankshaft installer pot**

**90890-01274**

**Crankshaft installer bolt**

**90890-01275**

**Adapter (M12)**

**90890-01278**

**Spacer**

**90890-01288**

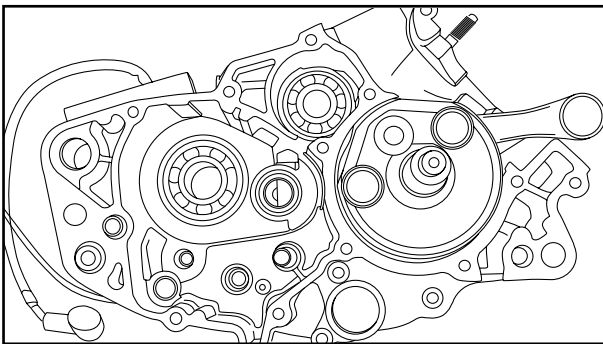

2. Install:
  - crankshaft assembly

### CAUTION

To avoid scratching the crankshaft and to ease the installation procedure, lubricate the oil seal lips with lithium-soap-based grease and each bearing with engine oil.

### NOTE:

Hold the connecting rod at top dead center (TDC) with one hand while turning the nut of the crankshaft installer bolt with the other. Turn the crankshaft installer bolt until the crankshaft assembly bottoms against the bearing.

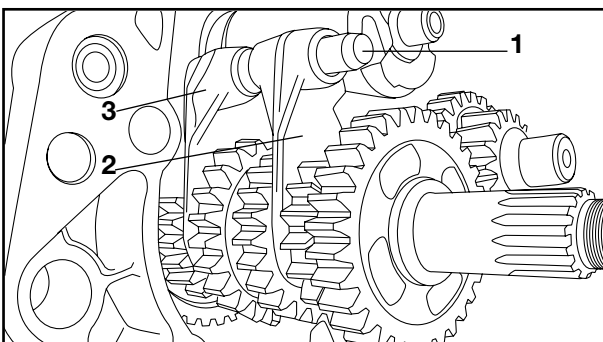

EAS00427

## INSTALLING THE SHIFT FORKS AND SHIFT DRUM ASSEMBLY

1. Install:
  - shift fork guide bars ①
  - shift fork "3" ②
  - shift fork "2" ③
  - shift fork "1" ④

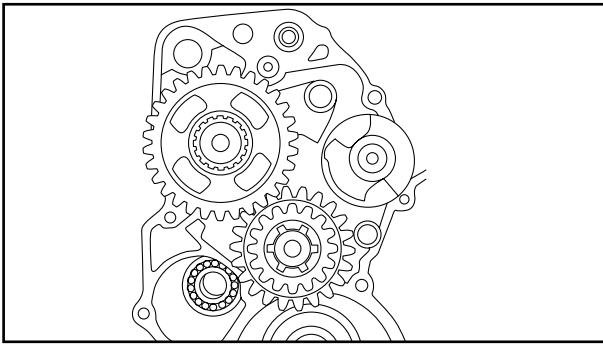

**NOTE:**

- The embossed marks mqRA.anq on the shift forks should face towards the left side of the engine and be in the following sequence: “3”, “2”, “1”.
- The grooved side of the shift fork guide bar should face towards the right side of the engine.

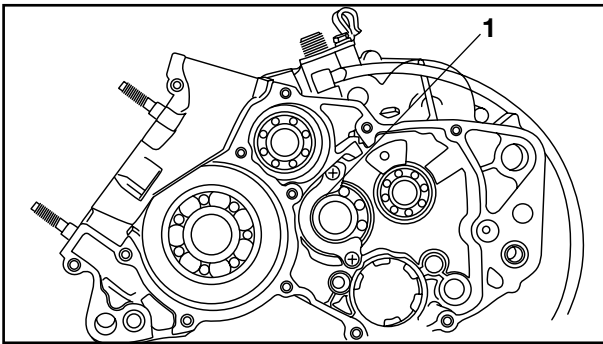

**CRANKCASE (RIGHT)**

1. Install:
  - Bearing retainer ①



**Screw (Bearing retainer):**  
**7 Nm (0.7 m•kg; 5.1 ft•lb)**  
**Use Loctite®**

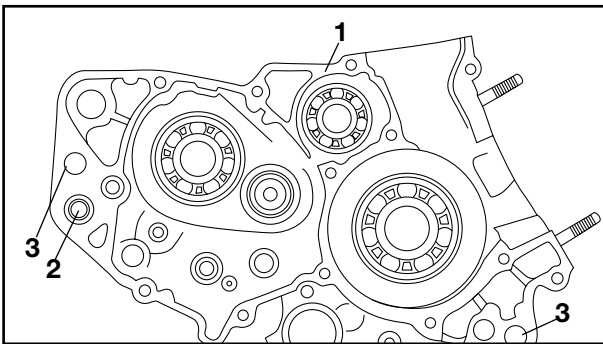

2. Apply:
  - yamaha Bond n°4 ①  
 (to mating surface of both crankcase halves)



**Yamaha Bond n°4:**  
**90890-05143**

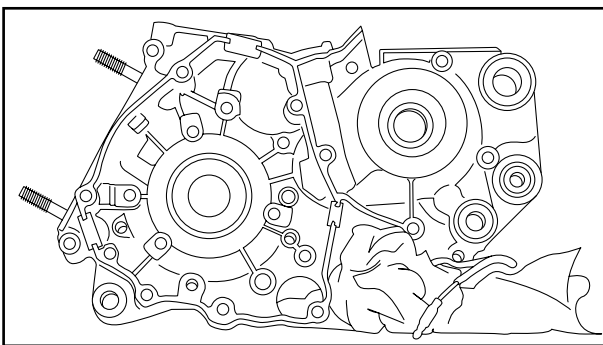

3. Install:
  - Damper collar ②
  - Dowel pins ③

4. Install:
  - Crankcase (Right)



**Installation steps:**

- Apply the lithium soap base grease to the oil seal lips.
- Fit the right crankcase onto the left case.  
 Tap lightly on the case with a soft hammer.

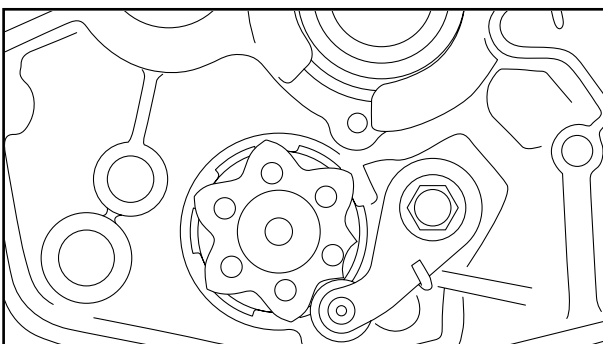

**NOTE:**

Turn the shift cam to the position shown in the figure so that it doesn't contact the crankcase when installing the crankcase.

- Install the water outlet pipe stay
- Tighten the bolts (Crankcase)



### CAUTION

Before installing and torquing the bolts (Crankcase) be sure to check wheter the transmission is functioning properly by manually rotating the shift cam either way.

### NOTE:

Tighten the bolts (Crankcase) in stage, using a crisscross pattern.



**Bolts(Crankcase):**  
8 Nm (0.8 m•kg; 5.8 ft•lb)

5. Apply:
  - 2 stroke oil  
(to crank pin, bearing and oil delivery hole).
6. Check:
  - Crankshaft and transmission operation  
Unsmooth operation → Repair.

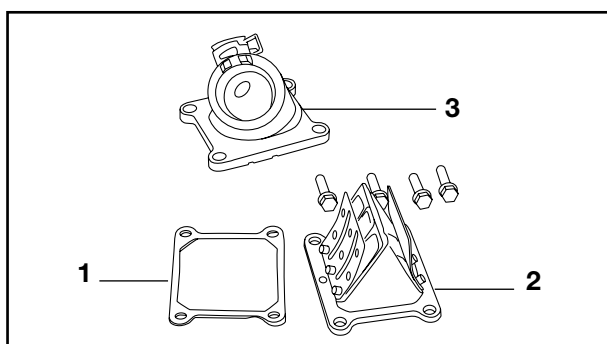

### REED VALVE

1. Install:
  - Breather hose (Crankcase)
  - Gasket ①
  - Reed valve assembly ②
  - Carburetor joint ③

### ⚠ WARNING

- Always use a new gasket.
- A damaged gasket may cause the engine revs to accelerate.

2. Tighten:
  - Bolts (Carburetor joint)



**Bolts(Carburetor joint):**  
8 Nm (0.8 m•kg; 5.8 ft•lb)



## MAGNETO ROTOR

- ① Stator assembly
- ② Rotor
- ③ Washer

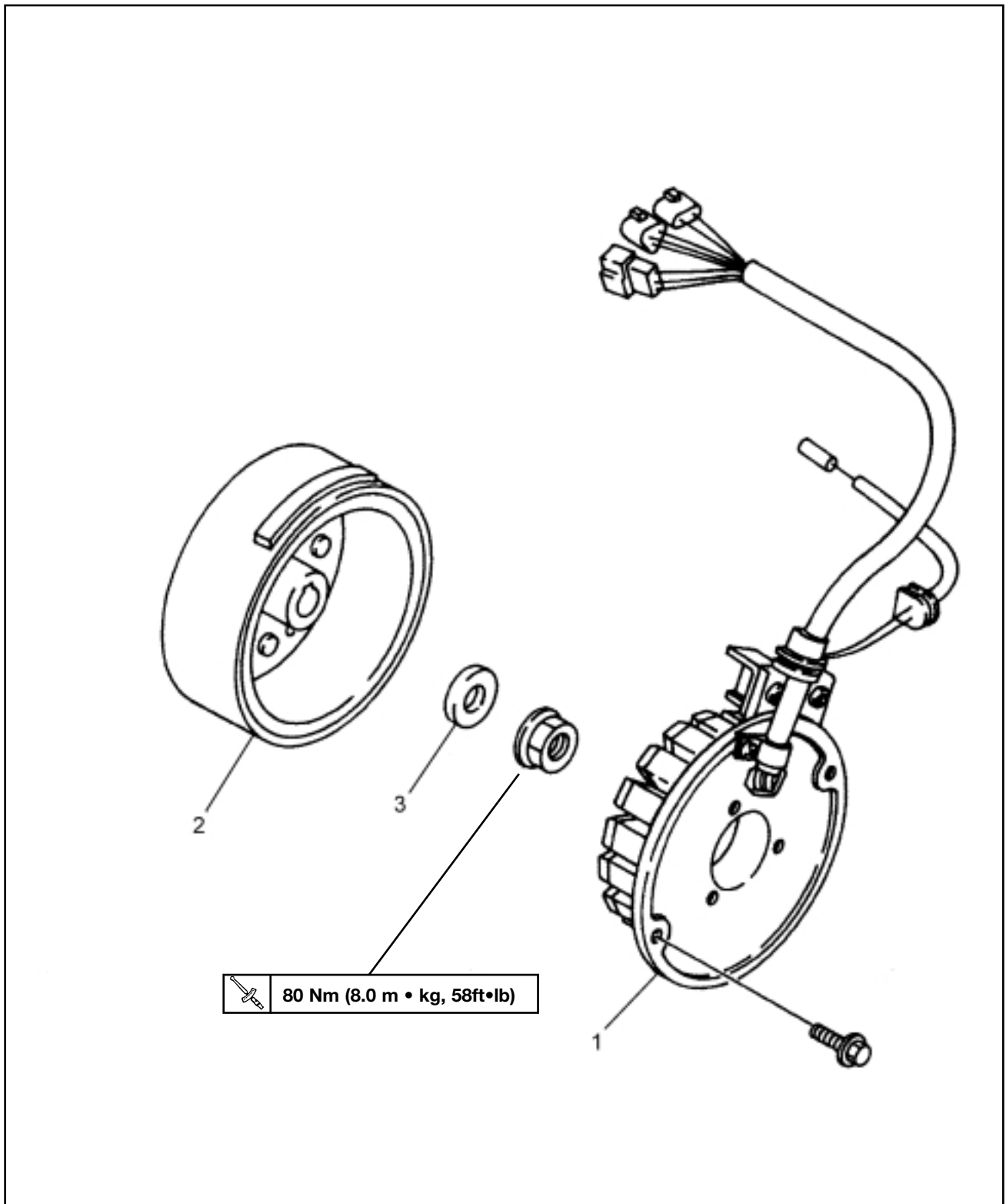



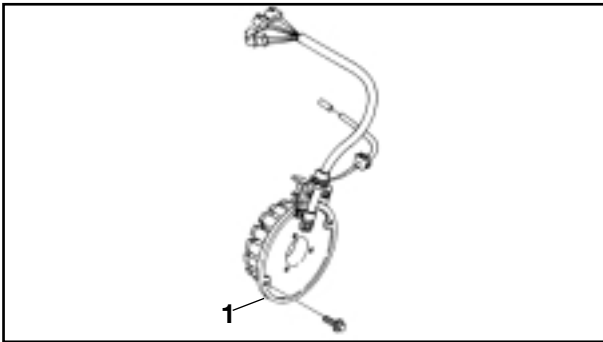

## MAGNETO ROTOR

1. Install:

- Stator ①



**Screw(Stator):**  
**8 Nm (0.8 m•kg; 5.8 ft•lb)**  
**Use Loctite®**

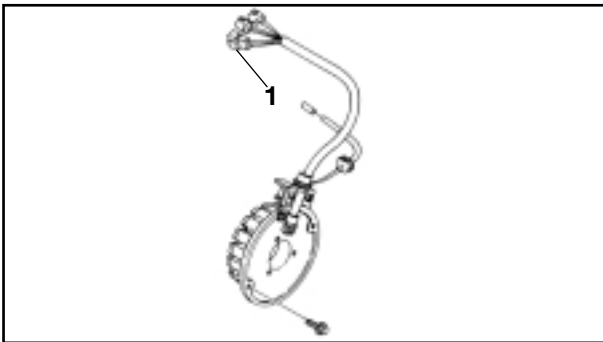

2. Connect:

- Neutral switch lead ①

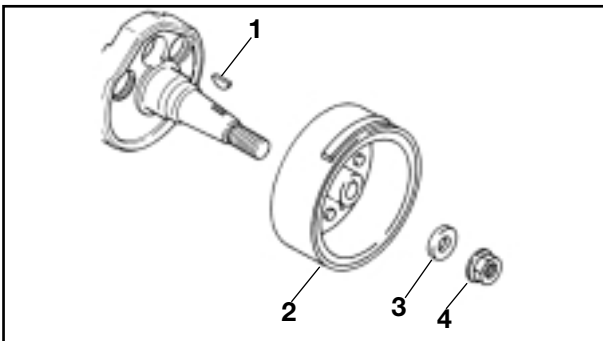

3. Install:

- Woodruff key ①
- Rotor ②
- Plain washer ③
- Nut (Rotor) ④

### NOTE:

- Clean the tapered portions of the crankshaft and rotor.
- When installing the rotor, make sure the key is properly seated in the key way of the crankshaft.
- Hold the rotor by the Rotor Holder to tighten the nut



**Universal Rotor Holder:**  
**90890-01235**



**Nut (Rotor):**  
**80 Nm (8.0 m•kg; 58 ft•lb)**





## SHIFT SHAFT

- ① Shift tank
- ② Spring
- ③ Circlip
- ④ Oil seal
- ⑤ Change pedal

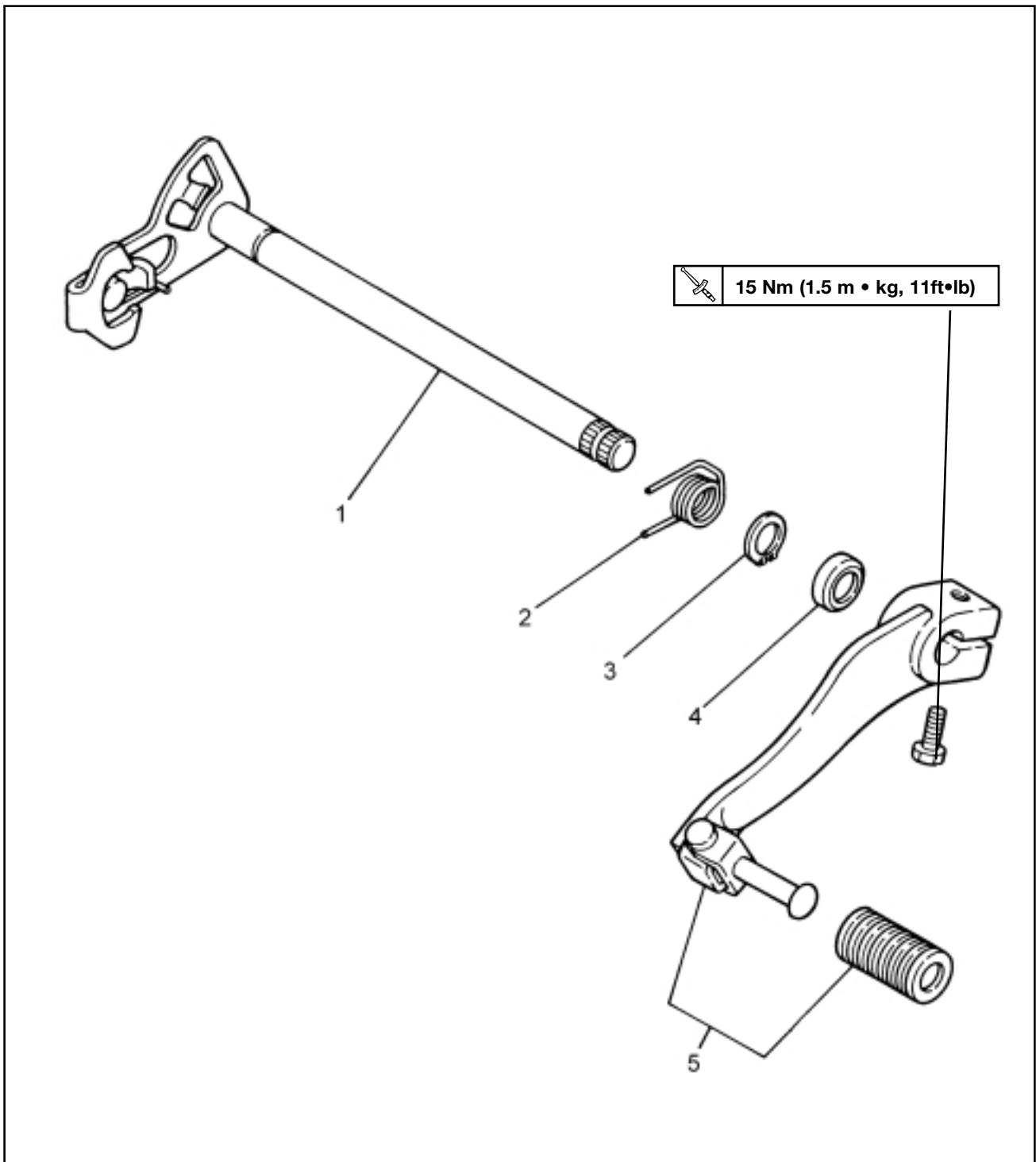

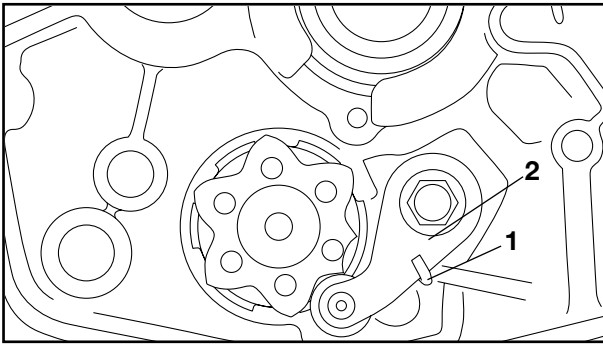

## STOPPER LEVER AND SHIFT SHAFT

1. Install:
  - Return spring ①
  - Stopper lever ②



**14Nm (1.4m•kg, 10 ft•lb)**

### NOTE:

- Mesh the stopper lever with the shift cam.

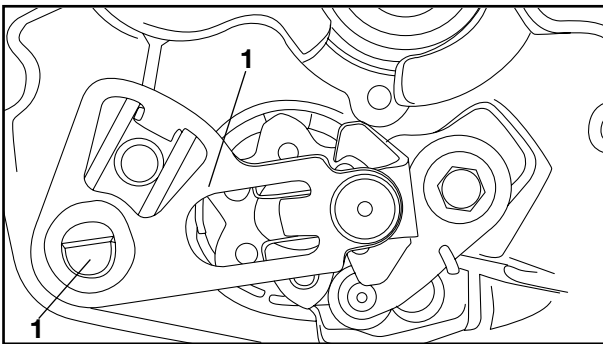

2. Install:
  - shift shaft ①

### NOTE:

- Lubricate the oil seal lips with lithium-soap-based grease.

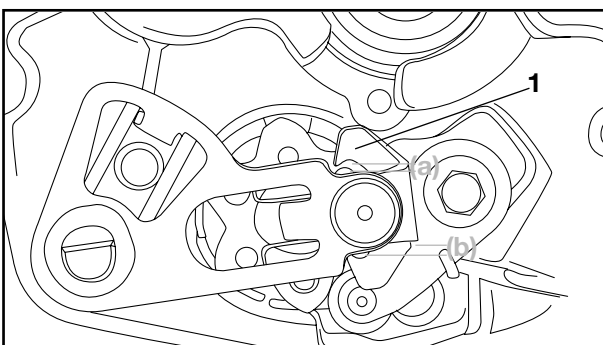

3. Check:
  - shift pawl ① position
  - Gaps (a) and (b) are not equal →
  - Replace the defective part(s).

② Shift cam

## CLUTCH PUSH LEVER

1. Lubricate:
  - Bearing ①
  - Oil seal lip ②
  - Washer ③
  - Push lever axle ④



**Lithium Soap Base Grease**

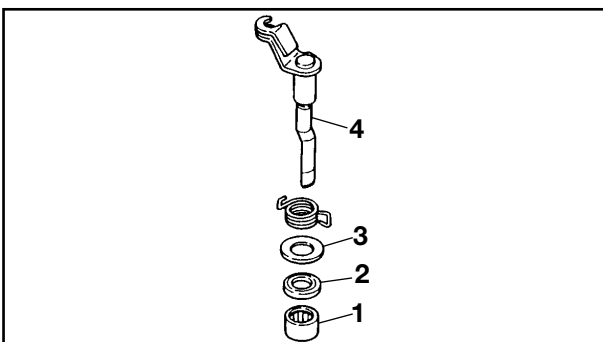

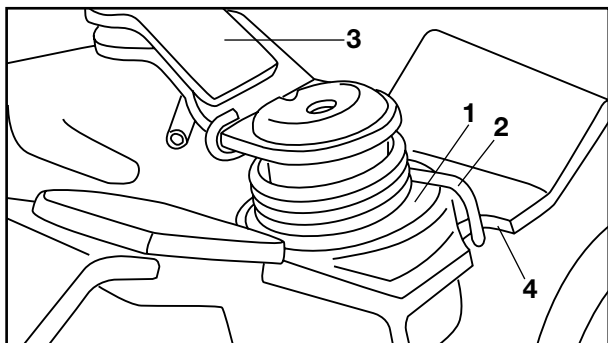

2. Install:
  - Washer ①
  - Return spring ②
  - Push lever ③
3. Set the return spring ② to the spring hook ④.



## CLUTCH AND PRIMARY DRIVE GEAR

- ① Clutch spring
- ② Pressure plate
- ③ Push plate
- ④ Clutch plate
- ⑤ Friction plate
- ⑥ Clutch damper
- ⑦ Clutch boss
- ⑧ Thrust washer
- ⑨ Clutch housing
- ⑩ Thrust plate
- ⑪ Conical spring washer
- ⑫ Push rod #1
- ⑬ Ball
- ⑭ Push rod #2
- ⑮ Push lever axle
- ⑯ Return spring
- ⑰ Bearing
- ⑱ primary drive gear

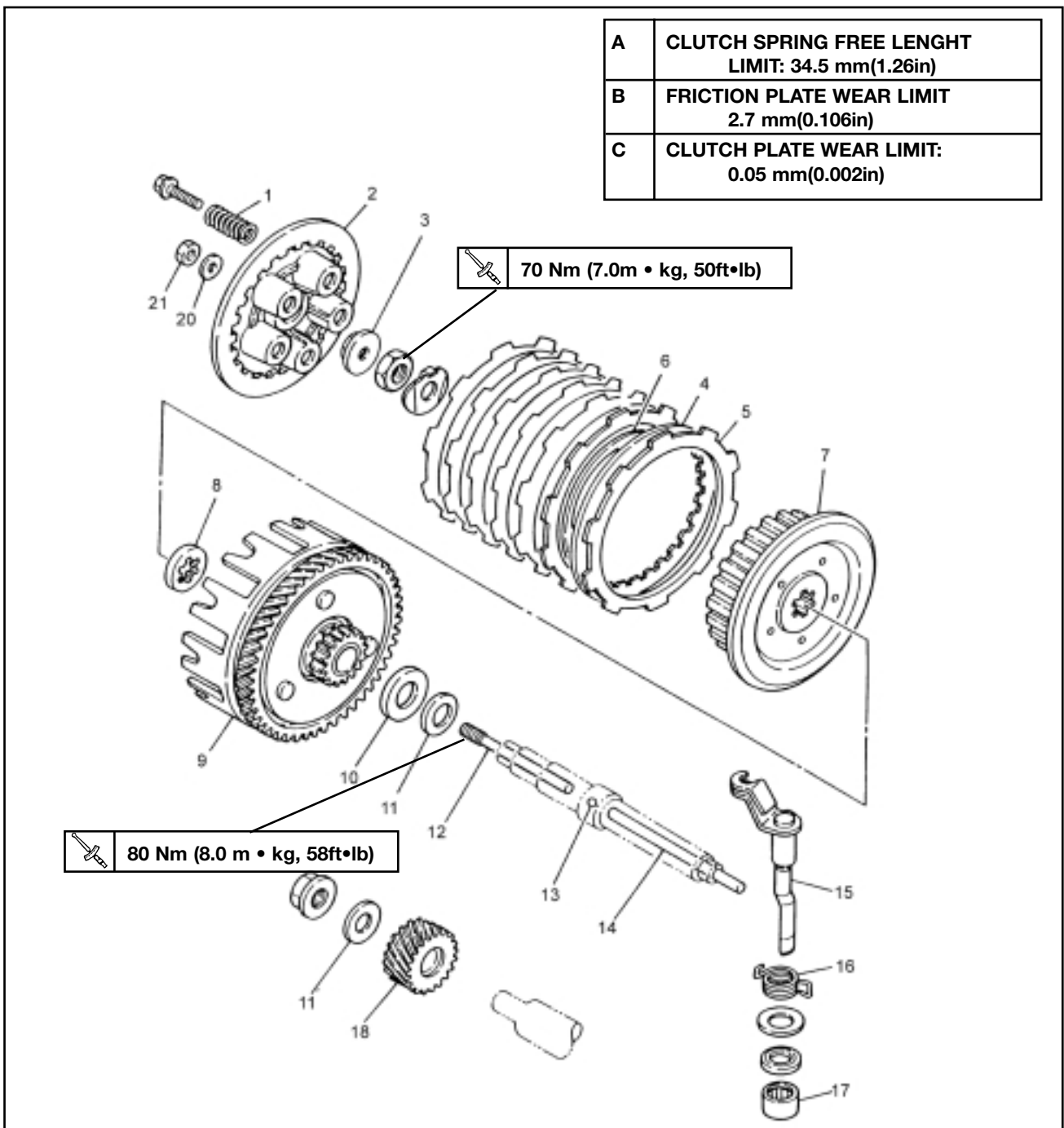

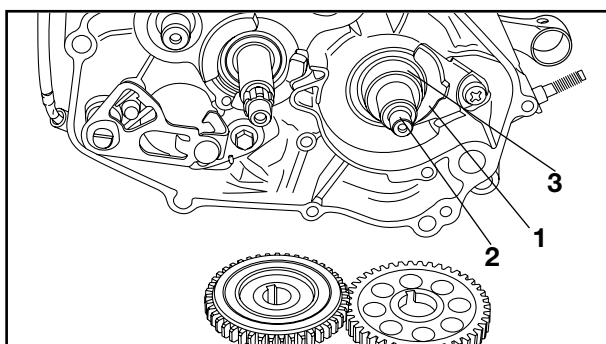

## BALANCER GEAR, PRIMARY DRIVE GEAR AND CLUTCH

1. Install:
  - Oil seal retainer ①
  - Spacer collar ②



**Oil Seal Retainer:**  
16 Nm (1.6 m•kg; 11 ft•lb)

### NOTE:

Before installing the spacer collar ② grease the oil seal lip ③.

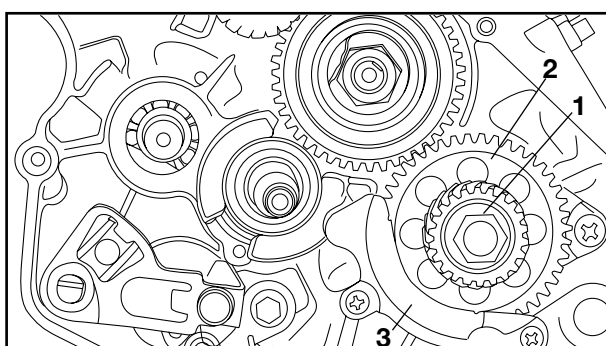

2. Install:
  - Straight key ①
  - Drive gear (Balancer weight) ②
  - Baffle plate ③



**Screw (Baffle Plate):**  
8 Nm (0.8 m•kg; 5.8 ft•lb)  
Use Loctite®

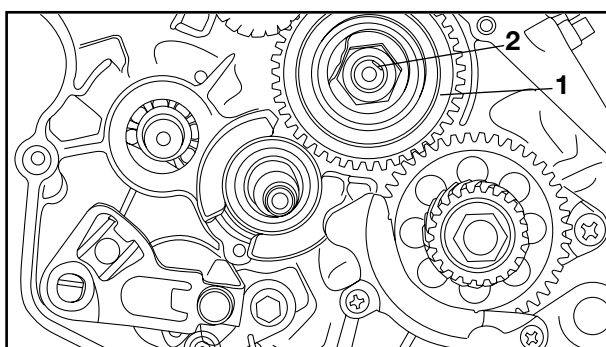

3. Install:
  - Driven gear (Balancer weight) ①
  - Straight key ②

### CAUTION

Align the balancer drive gear mark 3 with the balancer driven gear mark 4

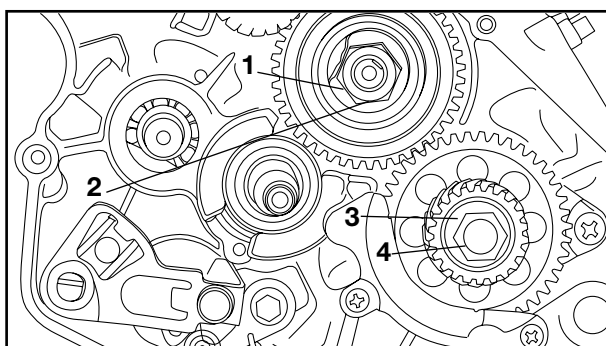

4. Install:
  - Lock washer ①
  - Nut (Balancer driven gear) ②
  - Plain washer ③
  - Nut (Primary drive gear) ④

### NOTE:

Install the lock washer tab ⑤ into the key way of the balancer driven gear ⑥.



### **WARNING**

Always use a new lock washer

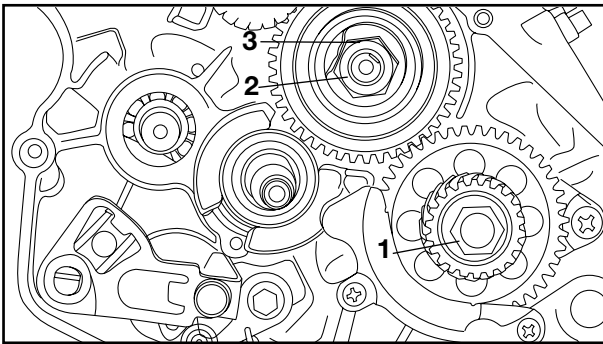

5. Tighten:

- Nut (Primary drive gear) ①
- Nut (Balancer driven gear) ②



**Nut (Primary drive gear):**  
80 Nm (8.0 m•kg; 58 ft•lb)  
**Nut (Balancer driven gear):**  
55 Nm (5.5 m•kg; 40 ft•lb)

### **NOTE:**

Hold the rotor to tighten the nut (Primary drive gear) ① and nut (Balancer driven gear) ② by the Universal Rotor Holder



**Universal Rotor Holder:**  
90890-01235

6. Bend the lock washer tab ③ along the nuts flats.

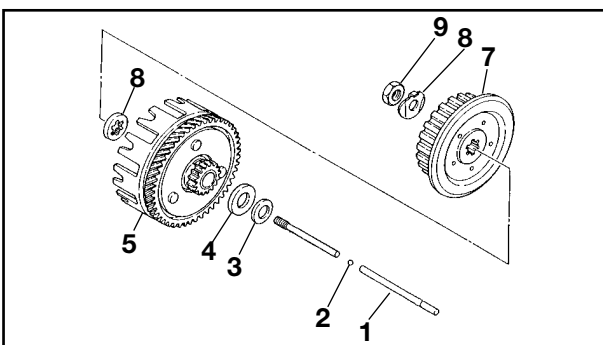

7. Lubricate:

- Push rod #2
- Ball ②



**Lithium Soap Base Grease**

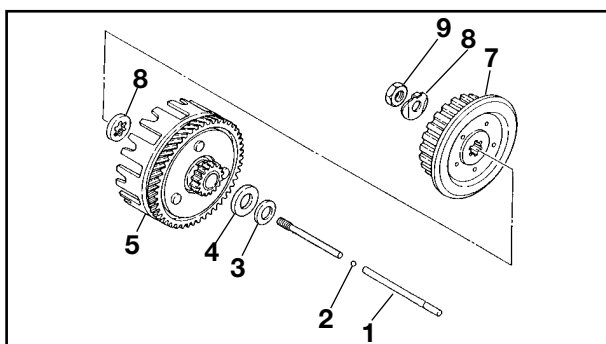

8. Install:
- Push rod #2
  - Ball ②
  - Conical spring washer ③
  - Thrust plate ④
  - Clutch housing ⑤
  - Thrust washer ⑥
  - Clutch boss ⑦
  - Lock washer ⑧
  - Nut (Clutch boss) ⑨

**⚠ WARNING**

Always use a new lock washer

**NOTE:**

- Be careful to install the conical spring washer ③ in proper position as shown.
- Install the lock washer tab ⑧ onto the indentation of the clutch boss.

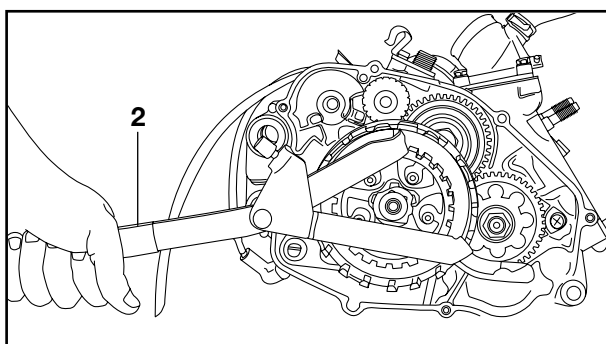

9. Tighten:
- Nut (Clutch boss)



**Nut (Clutch boss):**  
70 Nm (7.0 m•kg; 50 ft•lb)

**NOTE:**

Hold the clutch boss to tighten the nut ① (clutch boss) by the Universal Clutch Holder ②



**Universal Clutch Holder:**  
90890-04086

10. Bend the lock washer tab along the nut flats.



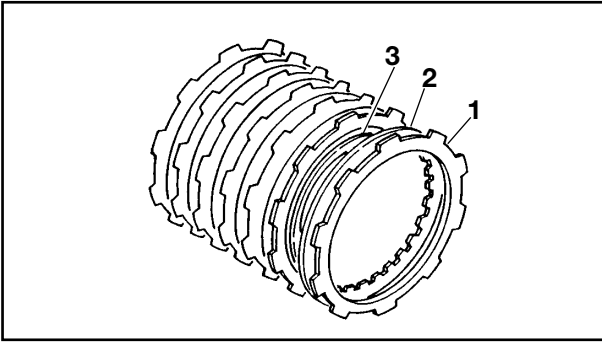

11. Install:
- Friction plates ①
  - Clutch plates ②
  - Clutch damper ③



**Installation steps**

- Install the friction plate onto the clutch boss.
- Install the clutch plate so as to locate the projection ④ at #1.
- Install the friction plate with the larger inside diameter onto the clutch boss.
- Install the clutch damper onto the clutch plate.
- Install the remaining clutch plates and friction plates alternately on the clutch boss.
- Be sure to install a clutch plate with projection offset approximately 60° from previous plate projection.  
Continue this procedure in a clockwise direction until all clutch plates are installed.

**NOTE:** \_\_\_\_\_

Before installing friction and clutch plates, sink them into transmission oil almost 3 hours before mounting

\_\_\_\_\_

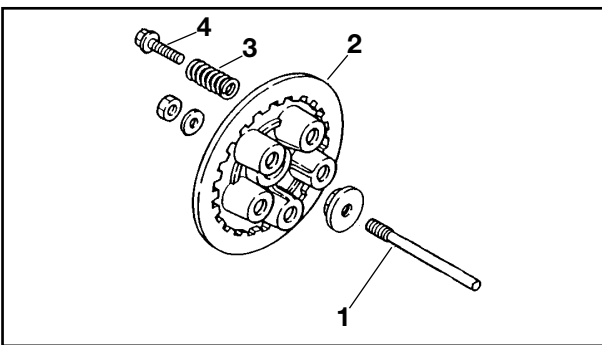
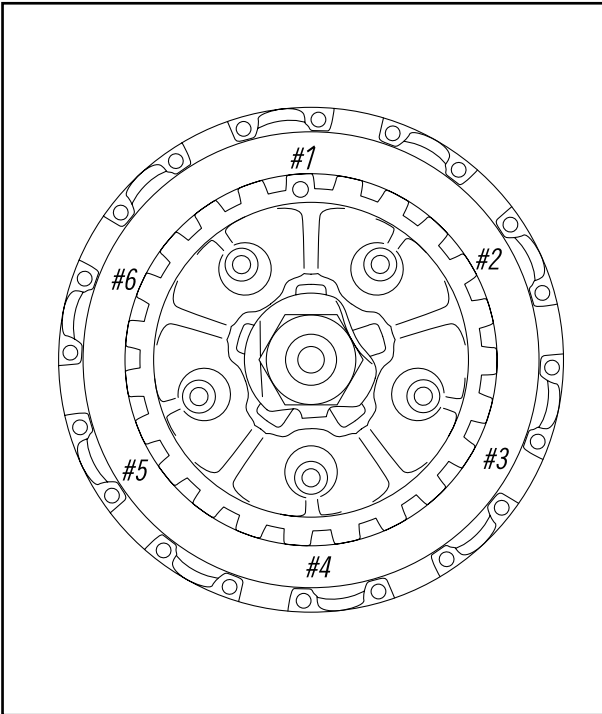

12. Install:
- Push rod #1 ①
  - Pressure plate ②
  - Clutch springs ③
  - Bolts (Pressure plate) ④

**NOTE:** \_\_\_\_\_

Align the punched mark ⑤ on the clutch boss with the punched mark ⑥ on the clutch pressure plate.

\_\_\_\_\_

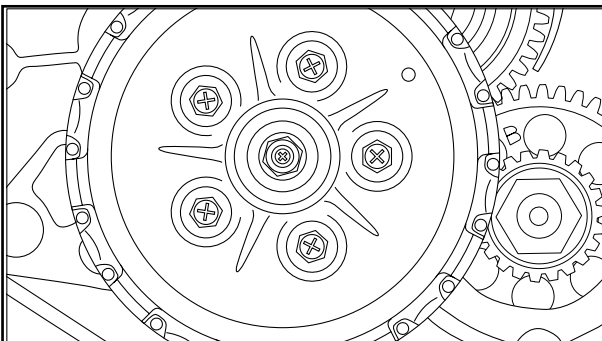

13. Tighten:
- Bolts (Pressure plate)

	<p><b>Bolt (Pressure plate):</b> 6 Nm (0.6 m•kg; 4.8 ft•lb)</p>
--	---





**NOTE:**

Tighten the bolts (pressure plate) in stage, using a crisscross pattern

14. Adjust:

- Clutch mechanism free play  
Refer to the "CLUTCH MECHANISM ADJUSTMENT" section in chapter 3.

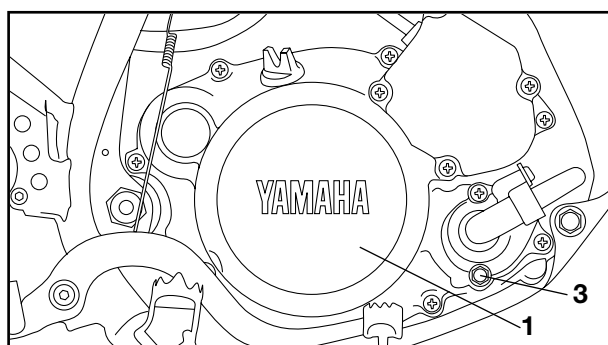

15. Install:

- Gasket (Crankcase cover)
- Dowel pins
- Crankcase cover (Right) ①
- Drain plug (Transmission oil) ②
- Drain plug (Coolant) ③

**NOTE:**

Tighten the screws (Crankcase cover) in stage using a crisscross pattern

**⚠ WARNING**

Always use a new gasket



**Screw (Crankcase cover):**  
8 Nm (0.8 m•kg; 5.8 ft•lb)  
**Drain plug (Transmission Oil):**  
15Nm (1.5 m•kg; 11 ft•lb)  
**Drain plug (Coolant):**  
10Nm (1.0 m•kg; 7.2 ft•lb)

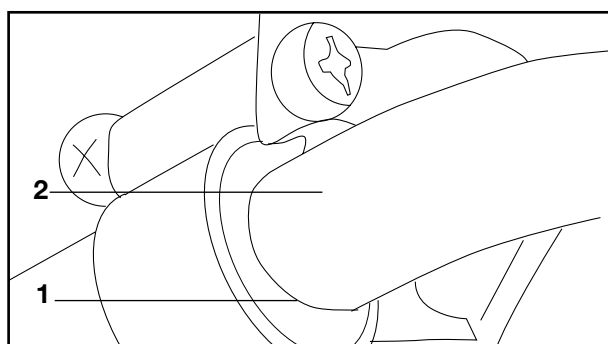

16. Apply the grease to the O-ring

17. Install:

- O-ring ①  
(to water outlet pipe ②)
- Water outlet pipe ②

**⚠ WARNING**

Always use a new O-ring



**Screw (Water Outlet Pipe):**  
8 Nm (0.8 m•kg; 5.8 ft•lb)



## CYLINDER HEAD AND CYLINDER

- ① Spark plug
- ② Cylinder head
- ③ Cylinder head gasket
- ④ Cylinder
- ⑤ Cylinder gasket

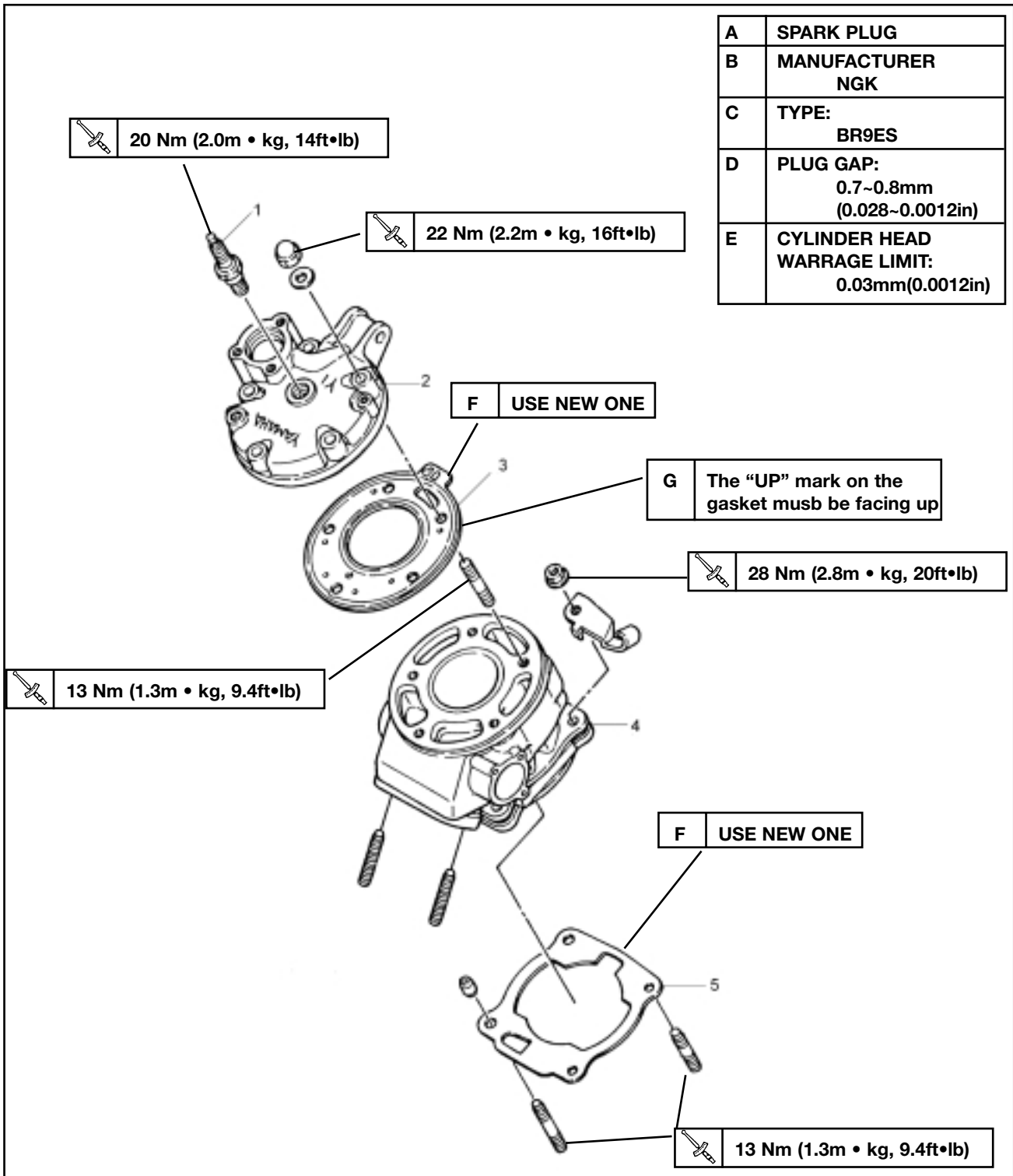

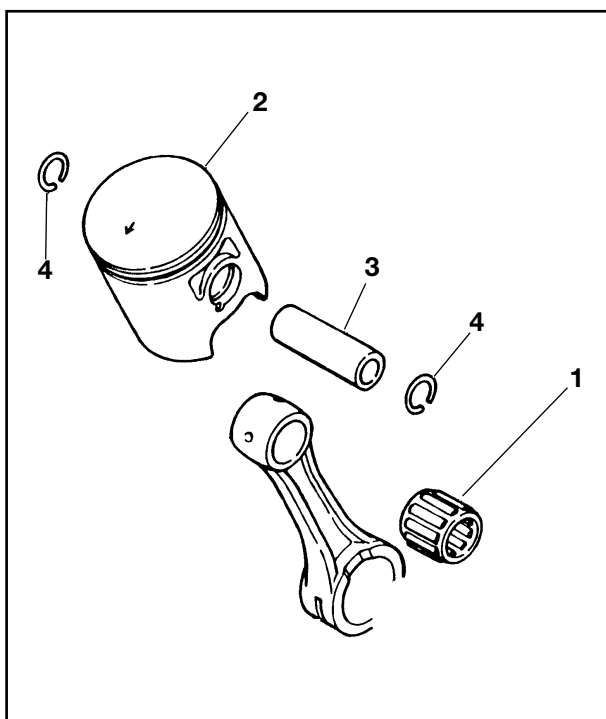

## PISTON, CYLINDER AND CYLINDER HEAD

1. Install:

- Bearing ①
- Piston ②
- Piston pin ③
- Piston pin clips ④

**NOTE:**

- Apply engineoil tothe piston pin, bearings and piston skirts areas.
- Make sure the arrow mark on the piston points towards the exhaust side of the cylinder.
- Before installing the piston pin clip, cover the crankcase opening with a clean rag to prevent the clip from falling into the crankcase.

### **⚠ WARNING**

**Always use a new piston pin clip**

### **CAUTION**

**Do not allow the clip open ends to meet the piston pin slot**

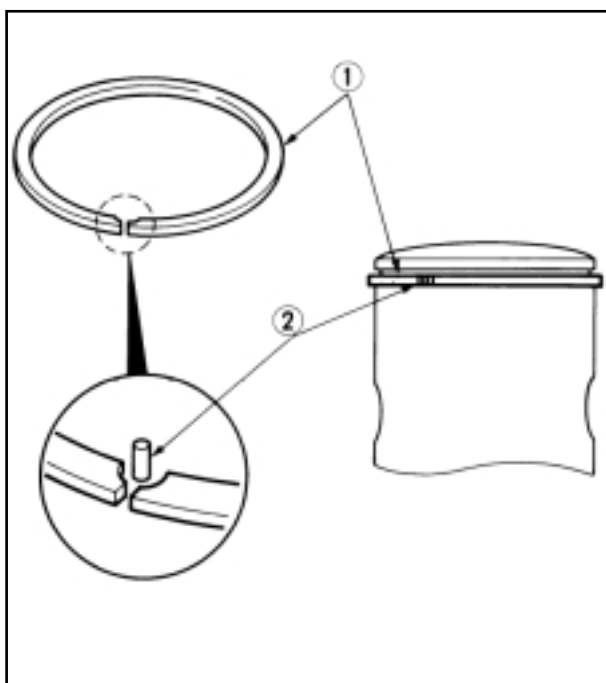

2. Check:

- Piston ring position

### **CAUTION**

- **Make sure ring ends are properly fitted around ring locating pins in piston grooves.**
- **Be sure to check te manufacture's marks or numbers stamped on the rings are on the top side of the rings.**

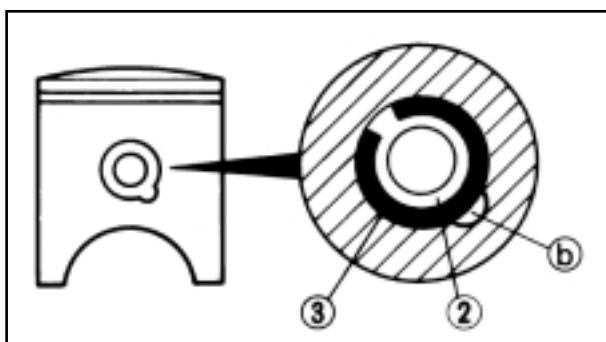

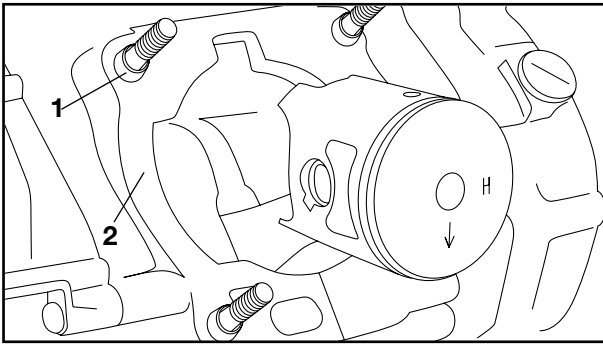

3. Install:
  - Dowel pins ①
  - Gasket **NEW** (Cylinder) ②

**⚠ WARNING**

Always use a new gasket

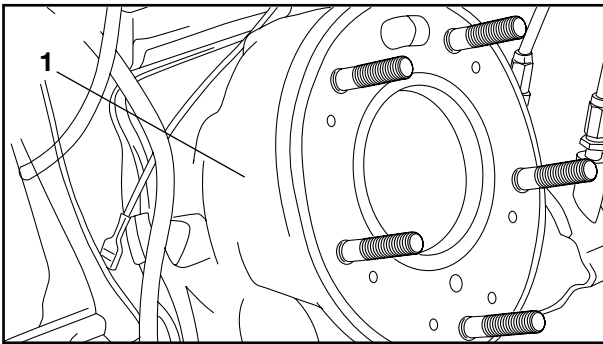

4. Install:
  - Cylinder ①
  - Clutch cable guide

**NOTE:**

Install the cylinder with one hand while compressing the piston rings with the other hand

5. Tighten:
  - Nuts (cylinder)



**Nut (Cylinder):**  
28 Nm (2.8 m•kg, 20 ft•lb)

**NOTE:**

Tighten the nuts ins stage using a crisscross pattern.

6. Install:
  - Gasket (Cylinder head)
  - Cylinder head

**⚠ WARNING**

Always use a new gasket

**NOTE:**

The “UP” mark on the gasket must be facing up

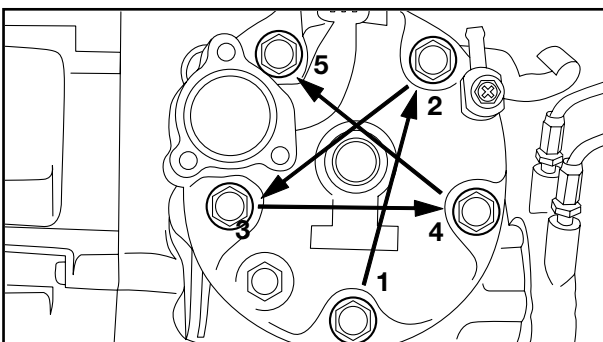

7. Tighten:
  - Nuts (Cylinder head)



**Nut (Cylinder Head):**  
22 Nm (2.2 m•kg, 16 ft•lb)

**NOTE:**

Tighten the nuts in stage, using a crisscross pattern

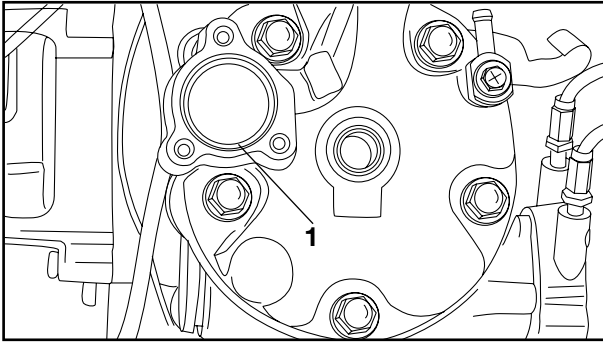

8. Install:
- O-ring ①
  - Thermostatic valve ②
  - Gasket ③

**NOTE:** \_\_\_\_\_

Apply the lithium soap base grease to the O-ring

**⚠ WARNING** \_\_\_\_\_

- Always use a new O-ring.
- Always use a new gasket.

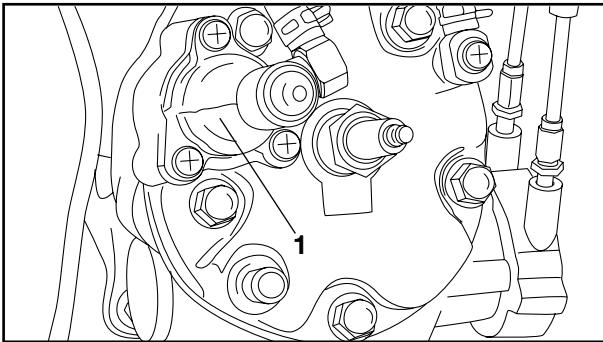
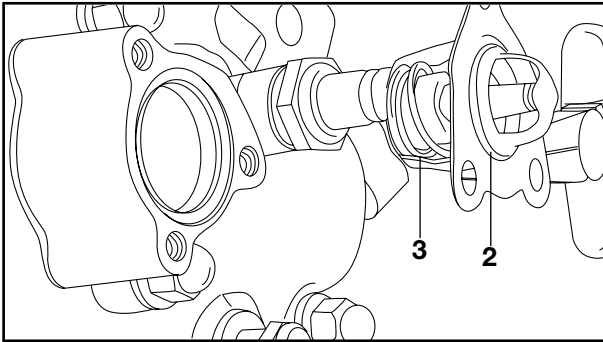

9. Install:
- Cover (Thermostatic valve) ①

 **Screw (Thermostatic Valve Cover):**  
8 Nm (0.8 m•kg, 5.8 ft•lb)

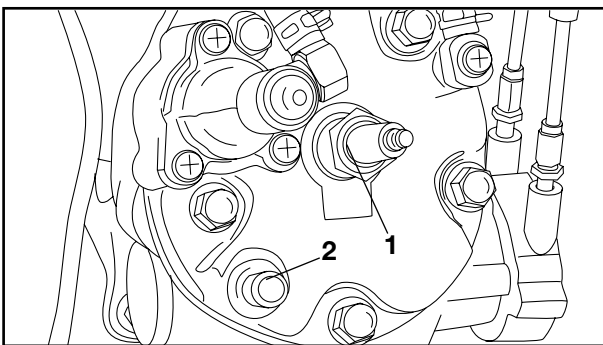

10. Install:
- Spark plug ①
  - Thermo unit ②

 **Spark plug:**  
20 Nm (2.0 m•kg, 14 ft•lb)  
**Thermo unit:**  
15 Nm (1.5 m•kg, 11 ft•lb)

**⚠ WARNING** \_\_\_\_\_

Handle the thermo unit with special care. Never subject it too strong or allow it to be dropped. In case of being hited, replace it.

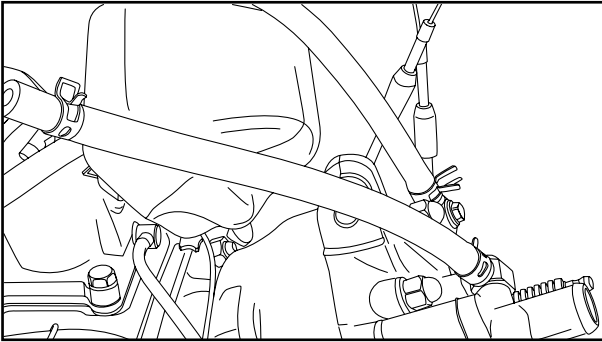

11. Install:
- Hoses (Inlet ① and outlet ②)



**Union bolt:**  
8 Nm (0.8 m•kg, 5.8 ft•lb)

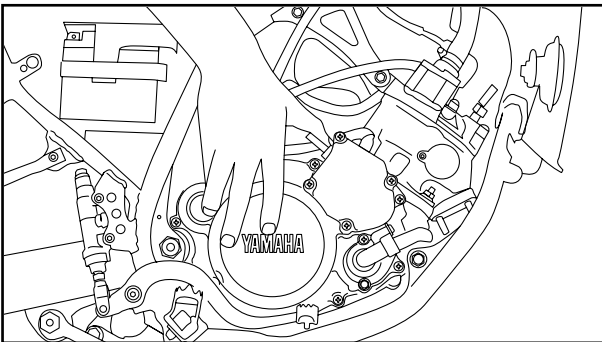

### REMOVING THE ENGINE

Reverse the "ENGINE REMOVAL" procedure. Note the following points:

1. Install:
- Engine assembly (to right side)
  - Mounting bolts



**Pivot shaft ①:**  
90 Nm (9.0 m•kg, 65 ft•lb)  
**Bolt ② (Rear → Lower):**  
33 Nm (3.3 m•kg, 24 ft•lb)  
**Bolt ③ (Front):**  
58 Nm (6.8 m•kg, 42 ft•lb)  
**Bolt ④ (Engine stay → Upper):**  
33 Nm (3.3 m•kg, 24 ft•lb)

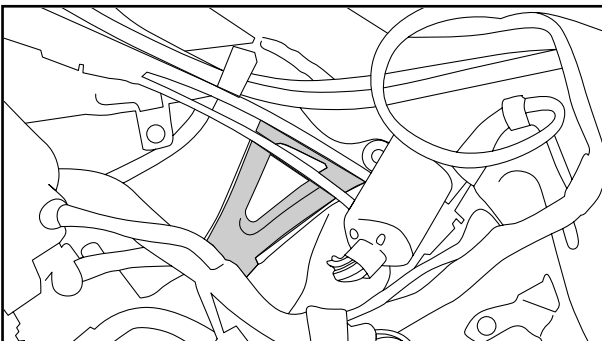

### NOTE:

- Apply lithium soap base grease to the pivot shaft.
- Temporarily tighten the bolts before tightening them to specification.

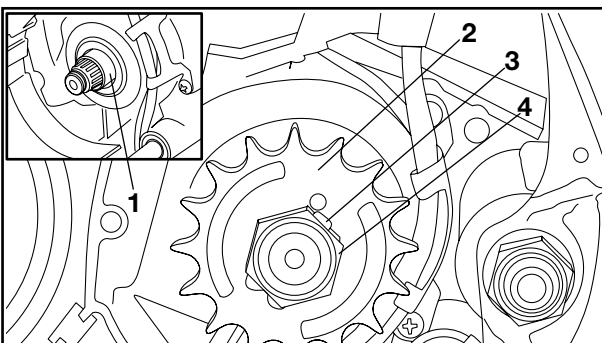

2. Install:
- Spacer collar ①
  - Drive sprocket ②
  - Lock washer ③
  - Nut (Drive sprocket) ④
  - Drive chain

### NOTE:

Before installing the spacer collar ① apply grease to the oil seal lip.



**Nut (Drive sprocket):**  
60 Nm (6.0 m•kg, 43 ft•lb)



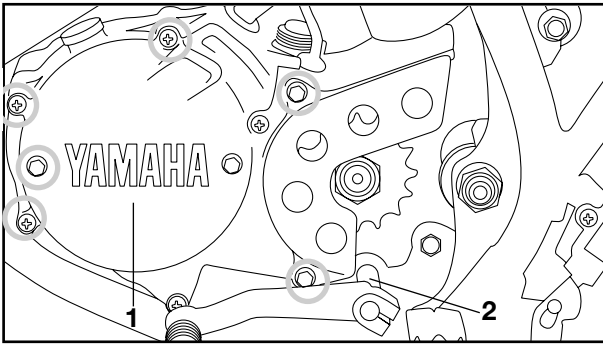

3. Bend the lock washer tab along the nut flats
4. Install:
  - Gasket (Crankcase cover)
  - Crankcase cover (Left) ①
  - Change pedal ②

**NOTE:** \_\_\_\_\_

Tighten the screws (Crankcase cover) in stage, using a crisscross pattern.

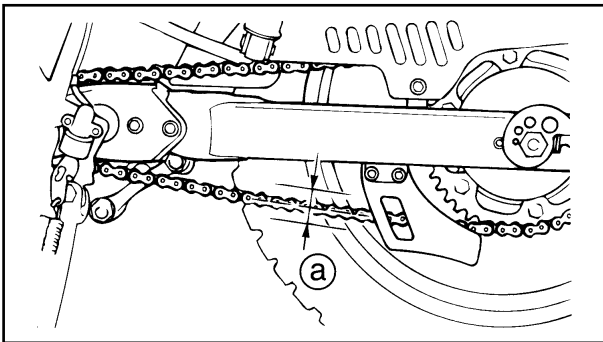

	<b>Screw (Crankcase cover):</b>
	<b>8 Nm (0.8 m•kg, 5.8 ft•lb)</b>
	<b>Bolt (Change pedal):</b>
	<b>15 Nm (1.5 m•kg, 11 ft•lb)</b>

5. Adjust:
  - Drive chain slack
 Refer to the “DRIVE CHAIN SLACK ADJUSTMENT” section in chapter 3.

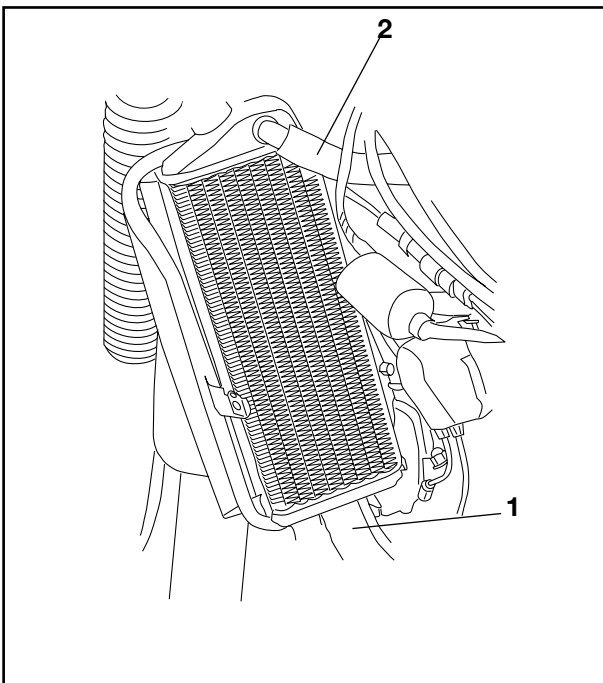

6. Connect:
  - Radiator hose (Outlet) ①
  - Radiator hose (Inlet) ②

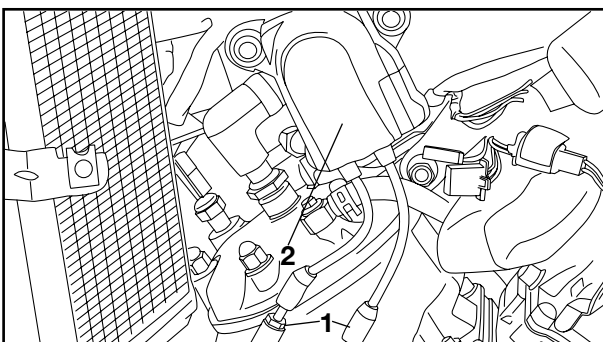

7. Install:
  - Pulley housing
  - Adjusters (Y.P.V.S. cables) ①
  - Servomotor unit ②

	<b>Bolt (Pulley housing):</b>
	<b>8 Nm (0.8 m•kg, 5.8 ft•lb)</b>
	<b>Screw (Servomoto unit):</b>
	<b>7 Nm (0.7 m•kg, 5.1 ft•lb)</b>



8. Connect:
- Servomotor unit lead
  - Cables (Y.P.V.S.)  
(to power valve pulley)

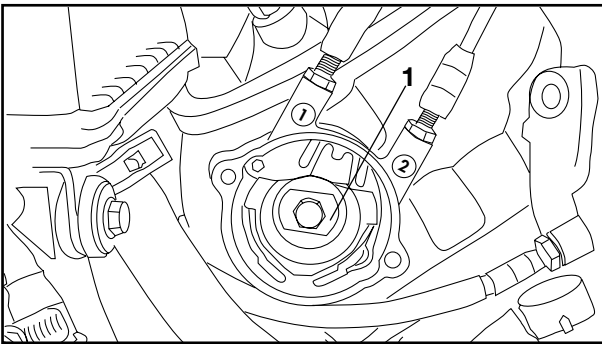

9. Install:
- Pulley (power valve) ①



**Bolt (Power valve pulley):**  
**10Nm (1.0 m•kg, 7.2 ft•lb)**

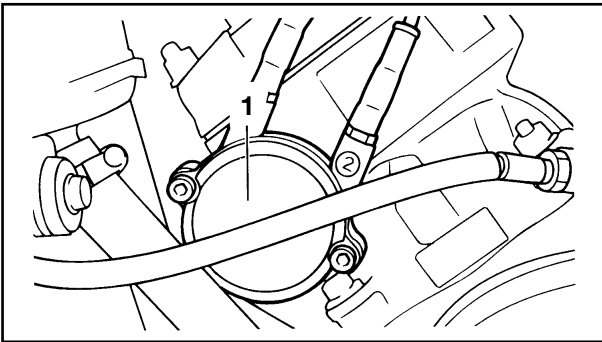

10. Adjust:
- Y.P.V.S. cables  
Refer to the “Y.P.V.S. CABLE ADJUSTMENT” section in chapter 3.

**NOTE:** \_\_\_\_\_

Before adjusting the Y.P.V.S. cables, turn the main switch “ON” and operate the Y.P.V.S. motor.

\_\_\_\_\_

11. Install:
- Pulley cover (Power valve) ①



**Bolt (Pulley Cover):**  
**7 Nm (0.7 m•kg, 5.1 ft•lb)**

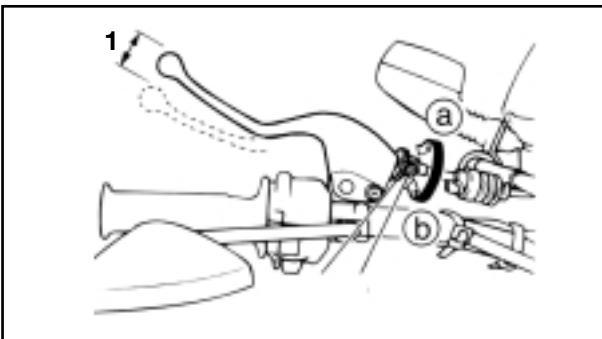

12. Adjust:
- Clutch cable free play ①  
Refer to the “CLUTCH ADJUSTMENT” section in chapter 3.





13. Air bleeding:
- Autolube pump  
Refer to the "AUTOLUBE PUMP AIR BLEEDING" section in chapter 3.

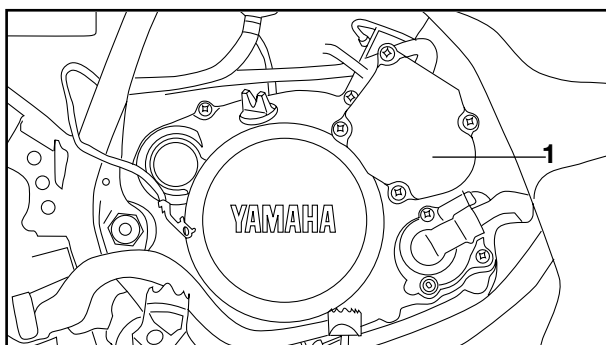

14. Install:
- Autolube pump cover ①

	<b>Bolt (Autolube pump cover):</b> 5 Nm (0.5 m•kg, 3.6 ft•lb)
---	--

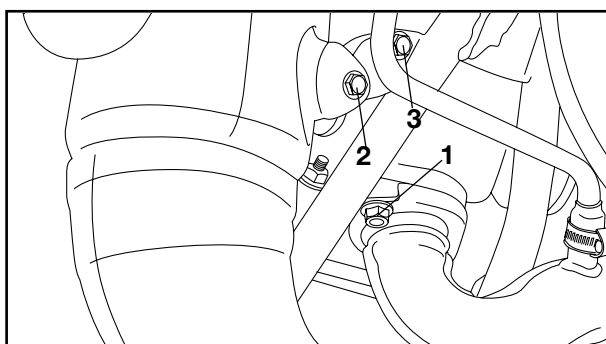

15. Install:
- Gasket (Exhaust pipe)
  - Exhaust pipe

	<b>Nut ① (Exhaust pipe):</b> 18 Nm (1.8 m•kg, 13 ft•lb)
	<b>Bolt ② (Stay):</b> 10 Nm (1.0 m•kg, 7.2 ft•lb)
	<b>Bolt ③ (Frame mount):</b> 10 Nm (1.0 m•kg, 7.2 ft•lb)
	<b>Screw ④ (Muffler joint):</b> 10 Nm (1.0 m•kg, 7.2 ft•lb)

**⚠ WARNING**

Always use a new gasket

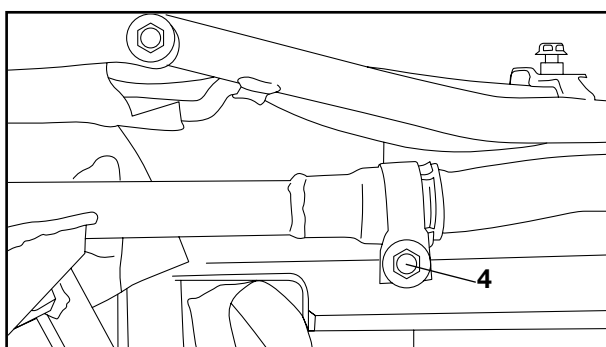

16. Fill:
- Radiator
  - Reservoir tank (Radiator)  
Refer to the "COOLANT REPLACEMENT" section in chapter 3.

	<b>Total amount:</b> 0,92L
---	-------------------------------



17. Fill:
- Crankcase  
Refer to the “TRANSMISSION OIL REPLACEMENT” section in chapter 3.



**Total amount:**  
**0,92L**

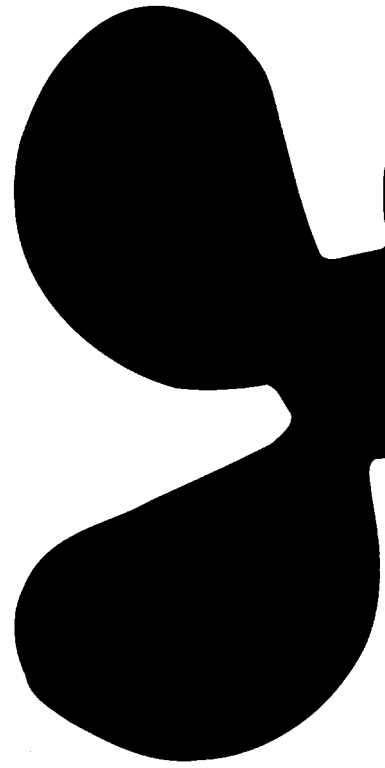

**COOL**

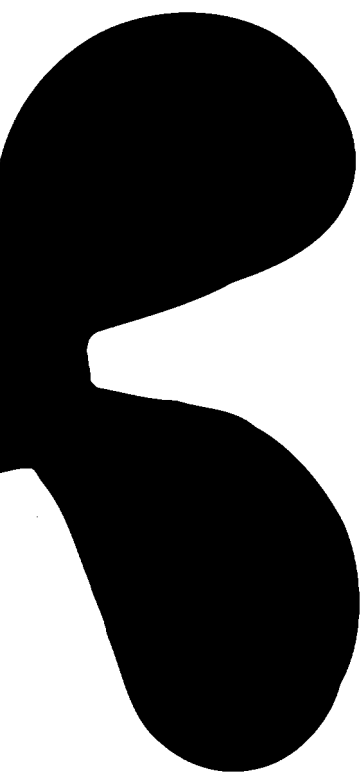

---

## CHAPTER 6 COOLING SYSTEM

<b>WATER PUMP</b> .....	6-1
REMOVAL .....	6-2
INSPECTION .....	6-4
INSTALLATION .....	6-4
<b>THERMOSTATIC VALVE AND RADIATOR</b> .....	6-7
REMOVAL .....	6-8
INSPECTION .....	6-10
INSTALLATION .....	6-11



COOLING SYSTEM

WATER PUMP

- ① Impeller shaft
- ② Oil Seal
- ③ Pin
- ④ Impeller shaft gear
- ⑤ Plain washer
- ⑥ Circlip
- ⑦ Water pump housing cover
- ⑧ Gasket
- ⑨ Dowel pin
- ⑩ Drain bolt
- ⑪ Gasket

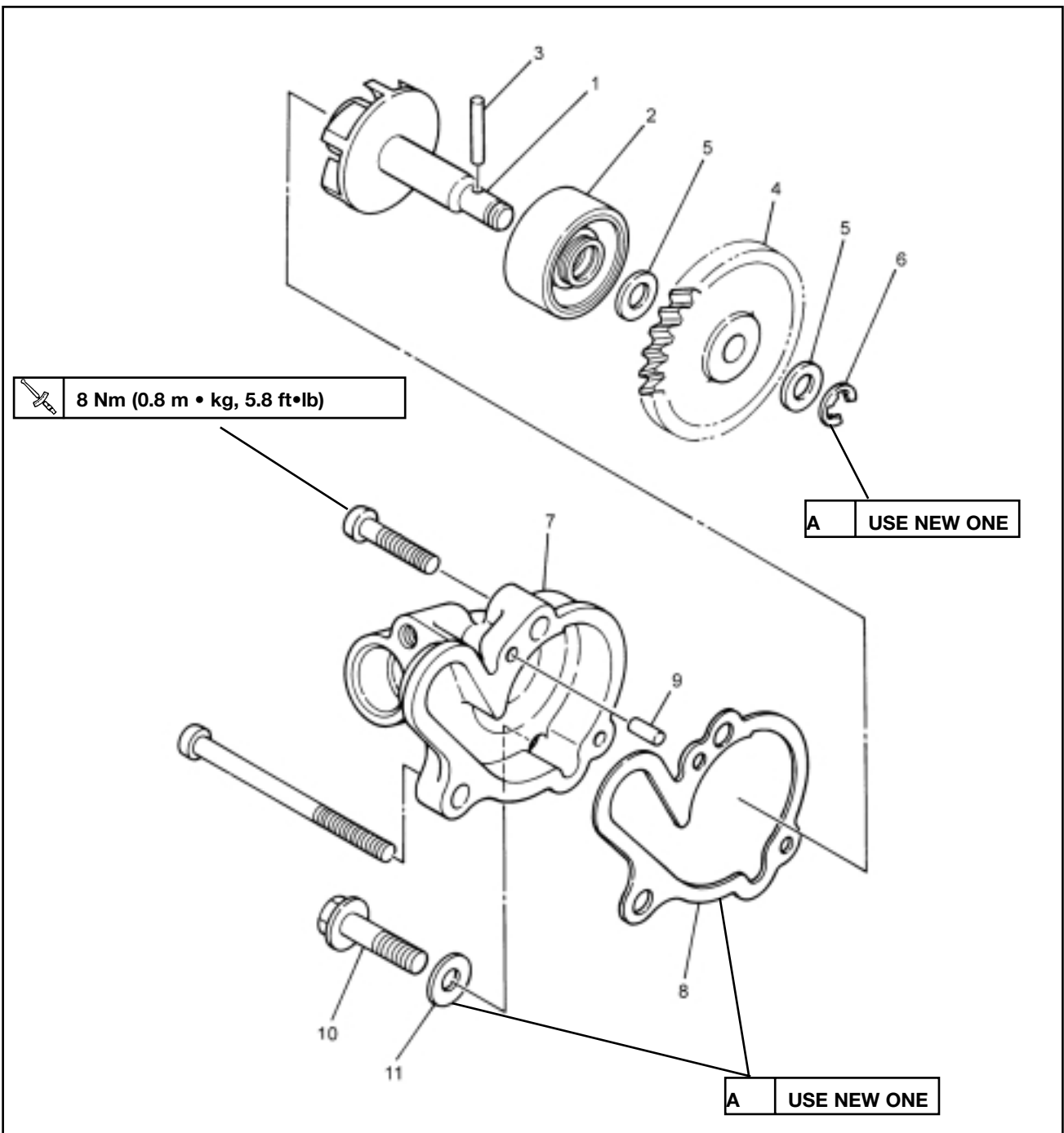



## REMOVAL

### NOTE:

It is necessary to disassemble the water pump unless there is no abnormality such as excessive change in coolant temperature and/or discoloration of coolant or milky transmission oil.

#### 1. Drain:

- Transmission oil  
Refer to the "TRANSMISSION OIL REPLACEMENT" section in chapter 3.
- Coolant  
Refer to the "COOLANT REPLACEMENT" section in chapter 3.

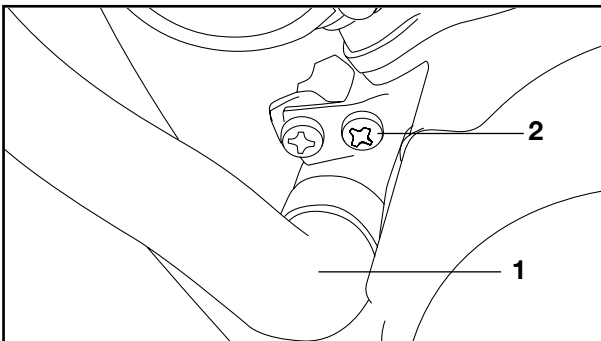

#### 2. Disconnect:

- Outlet hose (Radiator) ①

#### 3. Remove:

- Screw (Water outlet pipe) ②

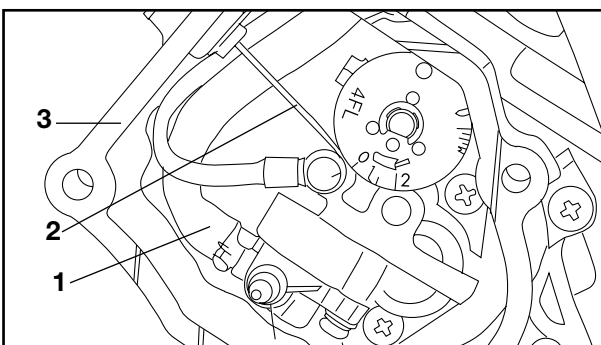

#### 4. Remove:

- Autolube pump cover

#### 5. Disconnect:

- Oil delivery hose ①

#### 6. Remove:

- Gasket (Autolube pump cover) ③
- Stopper clip (Pump cable)
- Clip (Pump cable outer)
- Autolube pump cable ②

### NOTE:

- Plug the oil hose so that oil will not run out of the oil tank.
- Turn the pump pulley counterclockwise by finger to make the pump cable loose enough for its end to be removed from the pulley.

## WATER PUMP

COOL

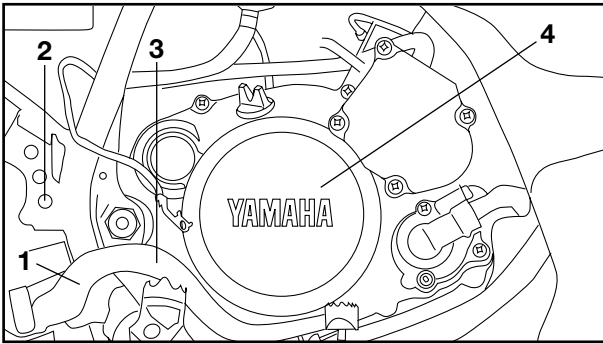

7. Remove:
- Return spring ①
  - Bolt (Master cylinder) ②
  - Brake pedal ③
  - Crankcase cover ④

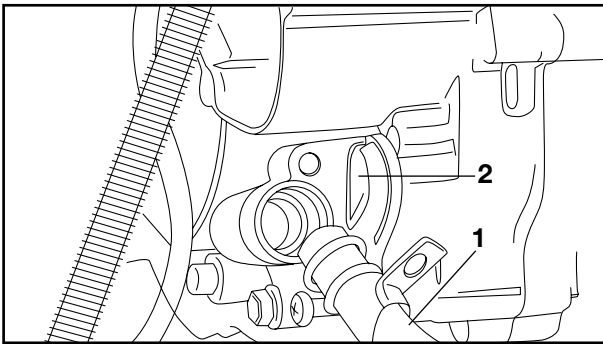

8. Remove:
- Water outlet pipe ①
  - Housing cover (Water pump) ②
  - Gasket
  - Dowel pins

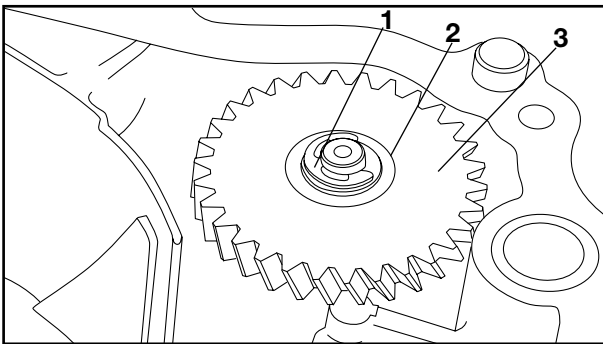

9. Remove:
- Circlip ①
  - Plain washer ②
  - Impeller shaft gear ③

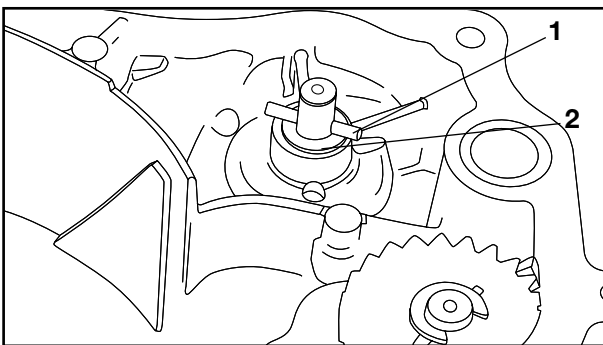

10. Remove:
- Pin ①
  - Plain washer ②

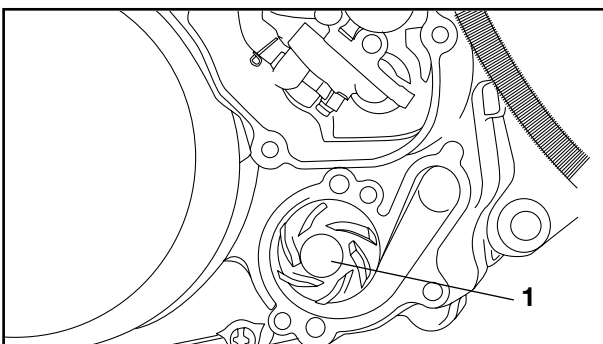

11. Remove:
- Impeller shaft ①
12. Eliminate deposits from the impeller and water pump housing.



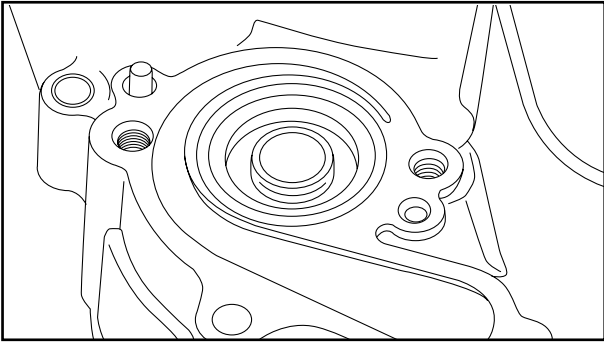

EAS00472

## CHECKING THE WATER PUMP

1. Check:

- O-ring  
Damage/wear → Replace.
- oil seal  
Damage/wear → Replace the water pump housing assembly.

2. Check:

- impeller  
Cracks/damage/wear → Replace the water pump housing assembly.
- bearing  
Rough movement → Replace the water pump housing assembly.



### Oil seal replacement steps:

- Remove the oil seal from the crankcase cover by tapping it towards the outside.
- Install the new oil seal with the “WATER SIDE” mark on the outside.

### NOTE:

- Apply the lightweight lithium base grease to oil seal outside.
- Press fit the oil seal until it contacts the bottom.



## INSTALL

Reverse the “REMOVAL” procedure. Note the following points.

1. Apply:

- Lightweight lithium base grease (to oil seal lips and impeller shaft)

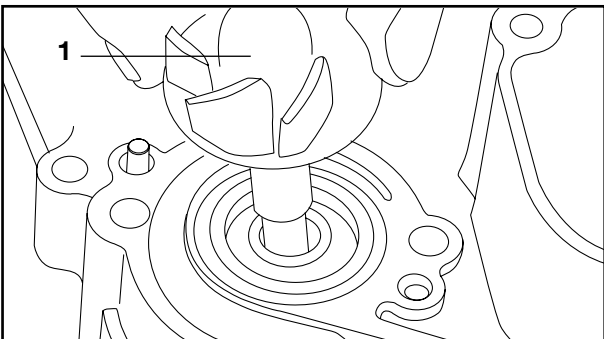

2. Install:

- Impeller shaft ①  
Install the shaft while turning it.

### NOTE:

Take care so that the oil seal lip is not damaged or the spring doesn't slip off its position.

## WATER PUMP

COOL

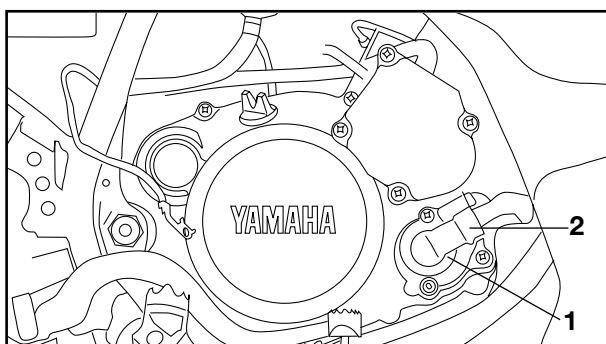

3. Install:

- Housing cover (Water pump) ①
- Water outlet pipe ②



**Screw (Crankcase cover):**  
8 Nm (0.8 m•kg, 5.8 ft•lb)  
**Screw (Water Outlet Pipe):**  
8 Nm (0.8 m•kg, 5.8 ft•lb)

### CAUTION

- Always use new gaskets
- Always use a new O-ring

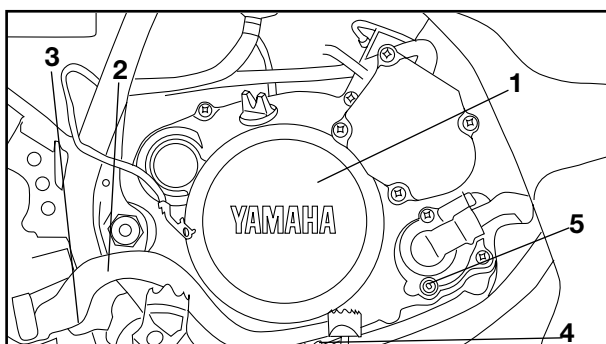

4. Install:

- Crankcase cover (Right) ①
- Brake pedal ②
- Return spring ③
- Drain plug (Transmission oil) ④
- Drain plug (Coolant) ⑤



**Screw (Crankcase cover):**  
8 Nm (0.8 m•kg, 5.8 ft•lb)  
**Screw (Brake pedal):**  
20 Nm (2.0 m•kg, 14 ft•lb)  
**Drain plug (Transmission Oil):**  
15 Nm (1.5 m•kg, 11 ft•lb)  
**Drain plug (Coolant):**  
10 Nm (1.0 m•kg, 7.2 ft•lb)

### NOTE:

Before installing the brake pedal apply lithium soap base grease to the brake pedal pivot shaft.

### WARNING

Always use new cotter pin and gasket.

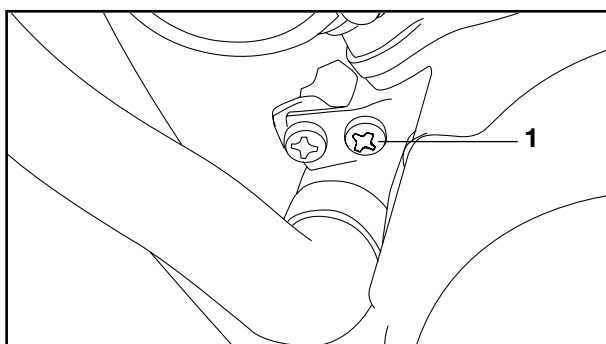

5. Install:

- Screw (Water outlet pipe) ①



**Screw (Water Outlet pipe):**  
8 Nm (0.8 m•kg, 5.8 ft•lb)

## WATER PUMP

COOL



6. Fill:

- Crankcase

Refer to the “TRANSMISSION OIL REPLACEMENT” section in chapter 3.



**Recommended Oil:**

**SAE 10W30 type SE Motor Oil**

**Periodic Oil Change:**

**0,75L**

7. Fill:

- Radiator

Refer to the “COOLANT REPLACEMENT” section.



**Total amount:**

**0,92L**

8. Air bleeding:

- Autolube pump

Refer to the “AUTOLUBE PUMP AIR BLEEDING” section.

9. Install:

- Autolube pump cover



**Screw (Autolube pump cover):**

**5 Nm (0.5 m•kg, 3.6 ft•lb)**

# THERMOSTATIC VALVE AND RADIATOR

COOL



## THERMOSTATIC VALVE AND RADIATOR

- ① Radiator assembly
- ② Radiator cap
- ③ Inlet hose
- ④ Coolant breather hose
- ⑤ Outlet hose
- ⑥ Gasket
- ⑦ Hose (Carburetor warmer → Inlet)
- ⑧ Hose (Carburetor warmer → Inlet)
- ⑨ Thermostatic valve cover
- ⑩ Gasket
- ⑪ Thermostatic valve
- ⑫ O-ring

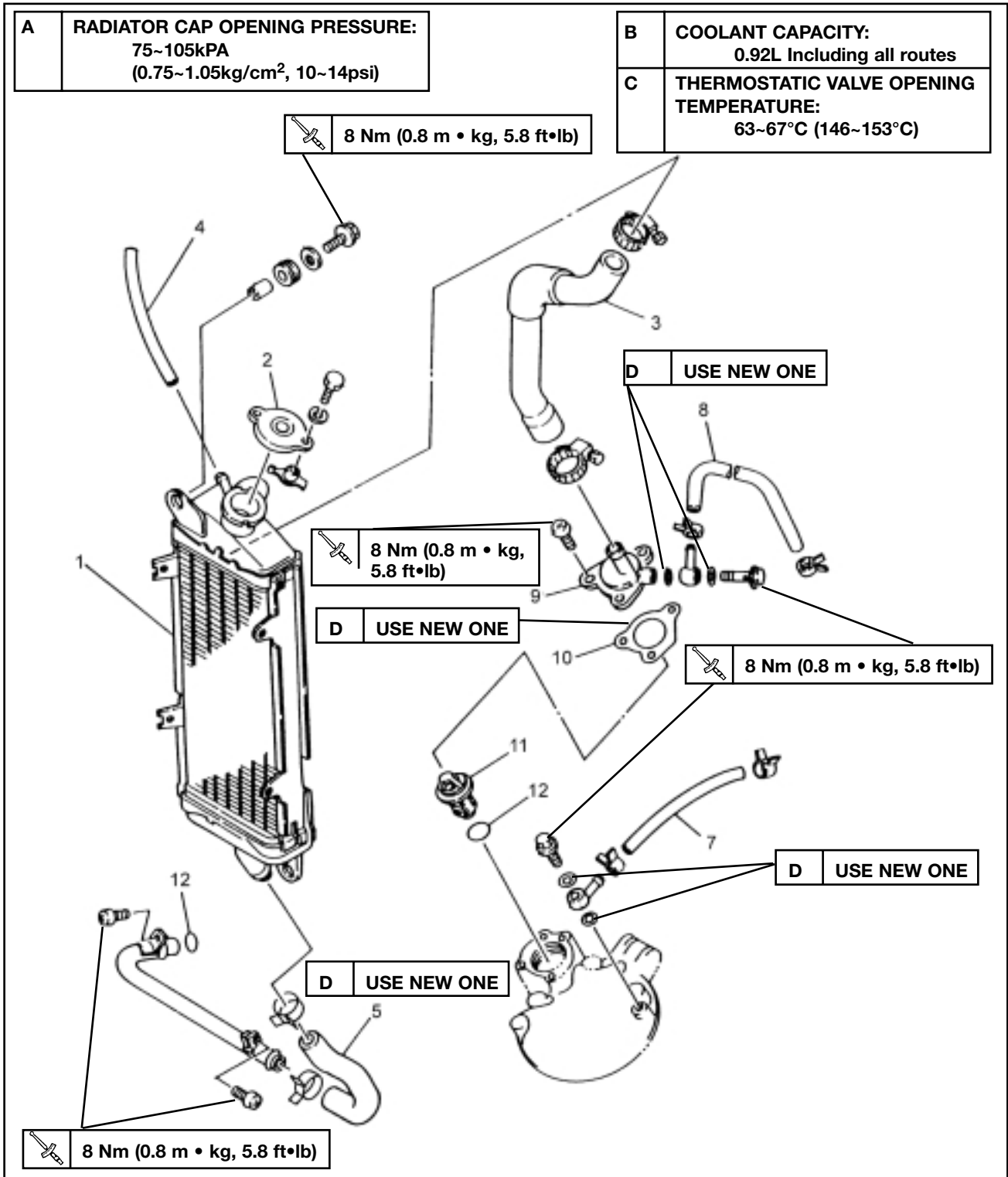

## THERMOSTATIC VALVE AND RADIATOR

COOL

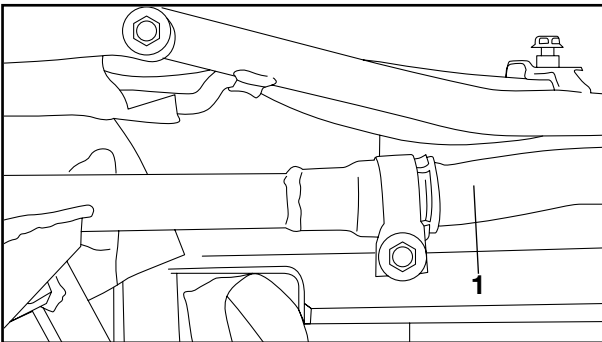
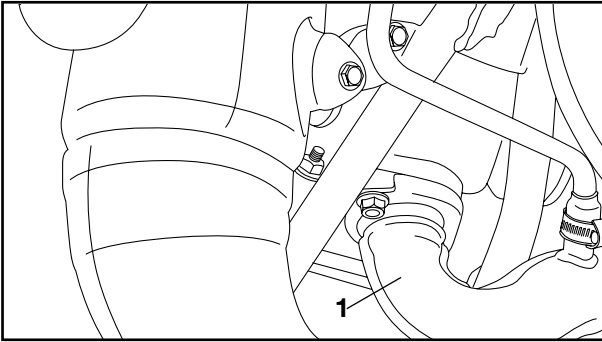

### REMOVAL

1. Remove:
  - Side covers (Left and Right)
  - Seat
  - Exhaust pipe ①
2. Remove:
  - Radiator cover
  - Oil tank cover
  - Fuel tankRefer to the "CARBURETOR REMOVAL" section in chapter 7.
3. Drain:
  - Cooling systemRefer to the "COOLANT REPLACEMENT" section in chapter 3.

### NOTE:

Thoroughly flush the cooling system with clean tap water.

### CAUTION

Take care so that coolant doesn't splash painted surfaces. If splashes, wash it away with water.

### ⚠ WARNING

Do not remove the radiator cap, drain bolts and hoses specially when the engine and the radiator are hot. Scalding hot fluid and steam may be blown out under pressure, which could cause serious injury. When the engine has cooled, place a thick rag like a towel over the radiator cap, slowly rotate the cap counterclockwise to detent. This procedure allows any residual pressure to escape. When the hissing sound stops, press down the cap while turning counterclockwise to remove it.

## THERMOSTATIC VALVE AND RADIATOR

COOL

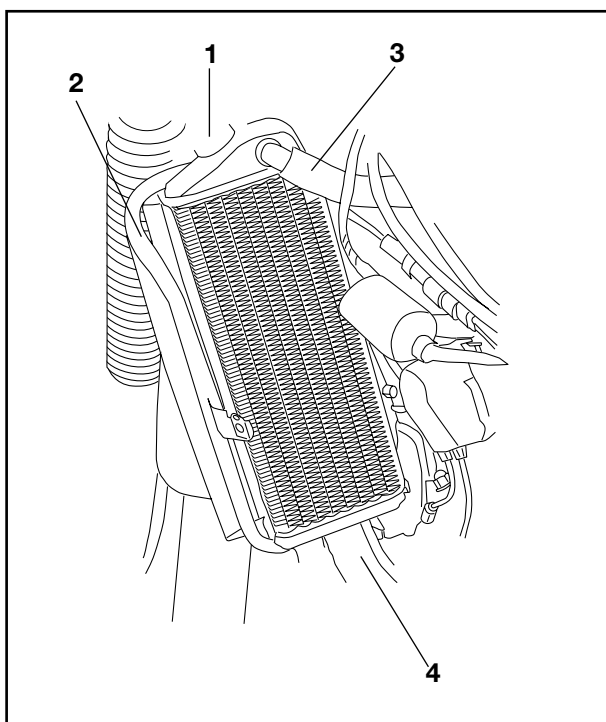

4. Remove:
  - Radiator cap ①
5. Disconnect:
  - Breather hose (Radiator) ②)
6. Remove:
  - Inlet hose (Radiator) ③
  - Outlet hose (Radiator) ④

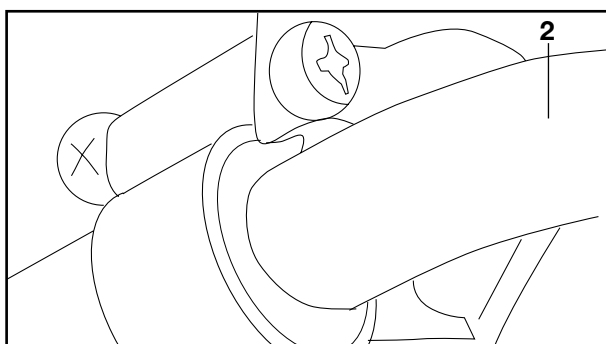

7. Remove:
  - Water outlet pipe ①
  - O-ring ②

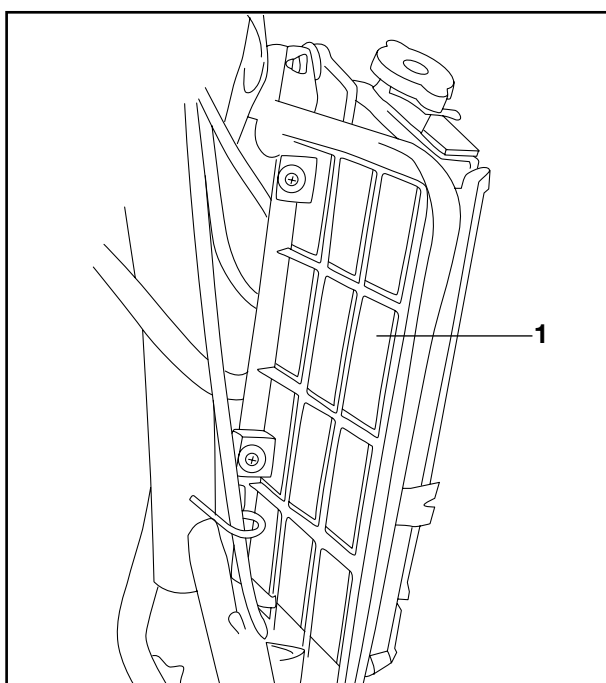

8. Remove:
  - Radiator fin ①

9. Remove:
  - Radiator

## THERMOSTATIC VALVE AND RADIATOR

COOL

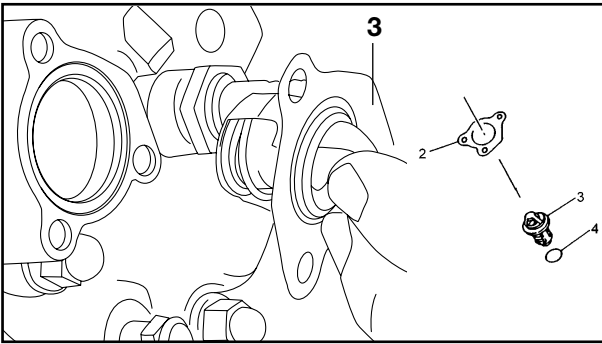

10. Remove:
- Thermostatic valve cover
  - Gasket ②
  - Thermostatic valve ③
  - O-ring ④

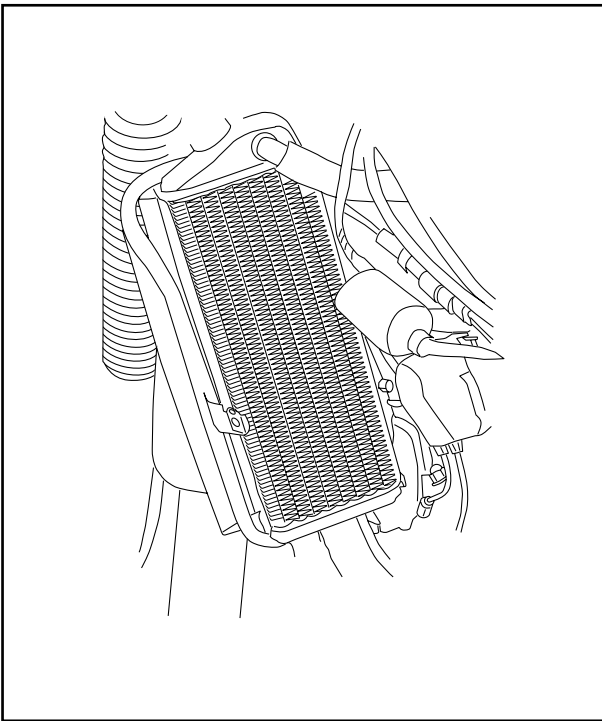

EAS00455

### CHECKING THE RADIATOR

1. Check:
- radiator fins  
Obstruction → Clean.  
Apply compressed air to the rear of the radiator.  
Damage → Repair or replace.

#### NOTE:

Straighten any flattened fins with a thin, flat-head screwdriver.

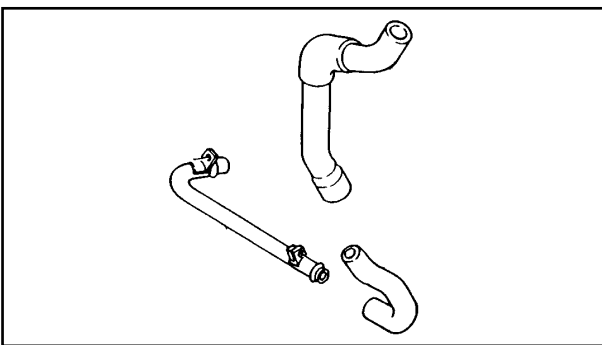

2. Check:
- radiator hoses
  - radiator pipes  
Cracks/damage → Replace.

3. Measure:
- radiator cap opening pressure  
Below the specified pressure → Replace the radiator cap.

**Radiator cap opening pressure**  
75~ 105 kPa  
(0.75 ~ 1.05 kg/cm<sup>2</sup>, 10 ~ 14 psi)





## THERMOSTATIC VALVE AND RADIATOR

COOL

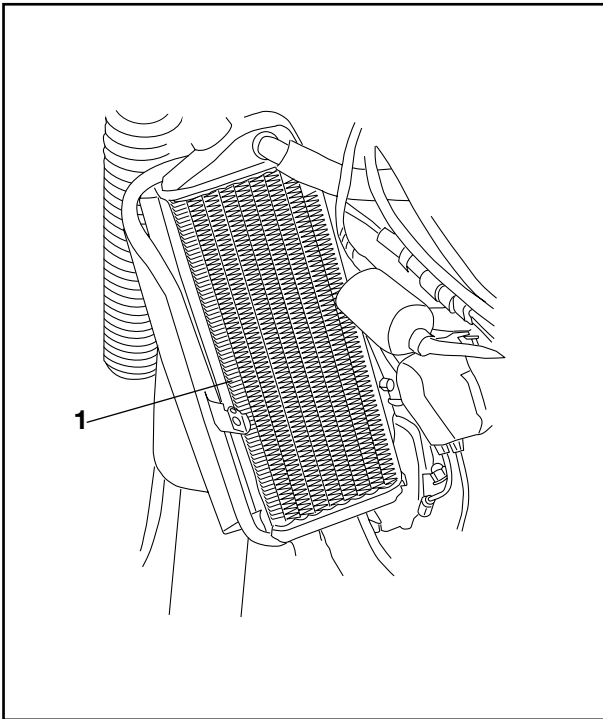

2. Install:
- Radiator ①



**Bolt(Radiator):**  
8 Nm (0.8 m·kg; 5.8 ft·lb)

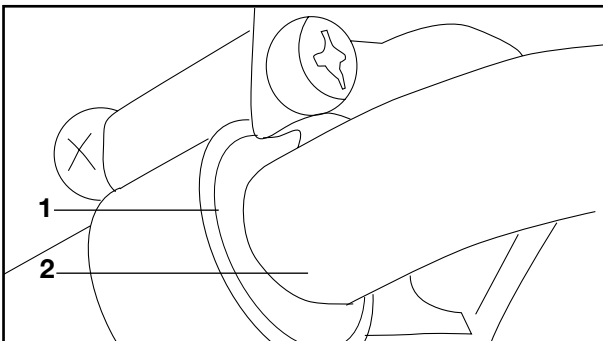

3. Apply grease to the O-ring ①
4. Install:
- O-ring ①
  - Water outlet pipe ②

### **⚠ WARNING**

**Always use a new O-ring**



**Screw (Water Outlet Pipe):**  
8 Nm (0.8 m·kg; 5.8 ft·lb)

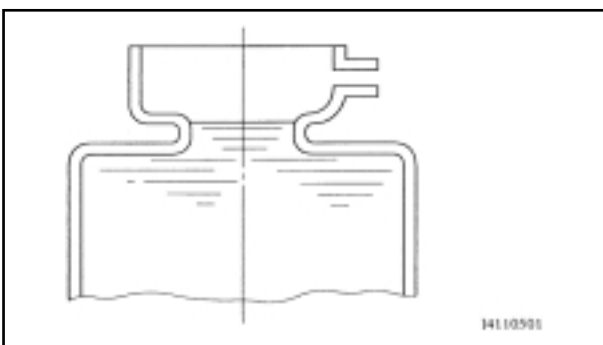

5. Fill:
- Radiator
  - Reservoir tank (Radiator)
- Refer to the "COOLANT REPLACEMENT" section in chapter 3.
6. Inspect:
- Cooling system
- Decrease of pressure (leaks)→Repair as required

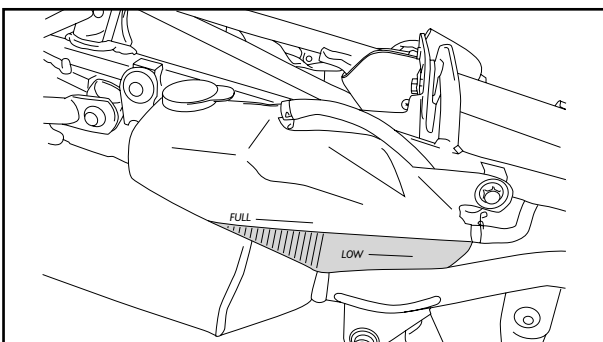



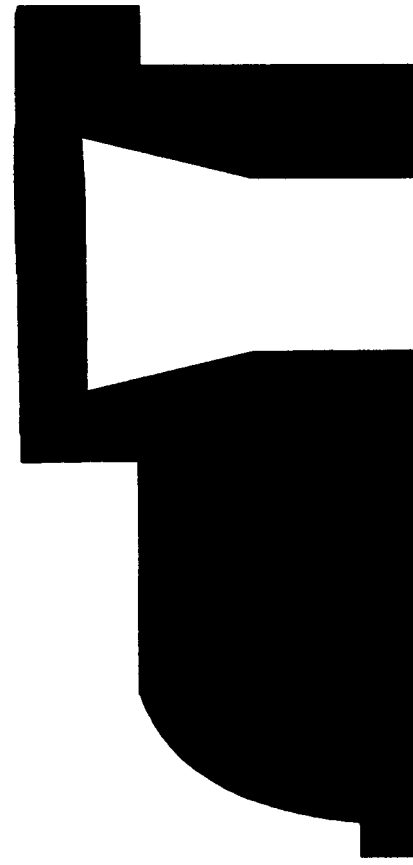

**CARB**



---

## CHAPTER 7 CARBURETOR

<b>CARBURETOR</b> .....	7-1
REMOVAL .....	7-2
DISASSEMBLY .....	7-3
INSPECTION .....	7-4
ASSEMBLY .....	7-6
INSTALLATION .....	7-8
ADJUSTMENT .....	7-9
<b>REED VALVE</b> .....	7-10
REMOVAL .....	7-11
DISASSEMBLY .....	7-11
INSPECTION .....	7-12
ASSEMBLY .....	7-12
INSTALLATION .....	7-13



CARBURETION

CARBURETOR

- ① Cap
- ② Throttle valve spring
- ③ Starter plunger
- ④ Throttle stop screw
- ⑤ Pilot air screw
- ⑥ Throttle valve
- ⑦ Needle set
- ⑧ Pilot jet
- ⑨ Needle jet
- ⑩ Gasket
- ⑪ Main jet
- ⑫ Needle valve assembly
- ⑬ Float
- ⑭ Drain screw

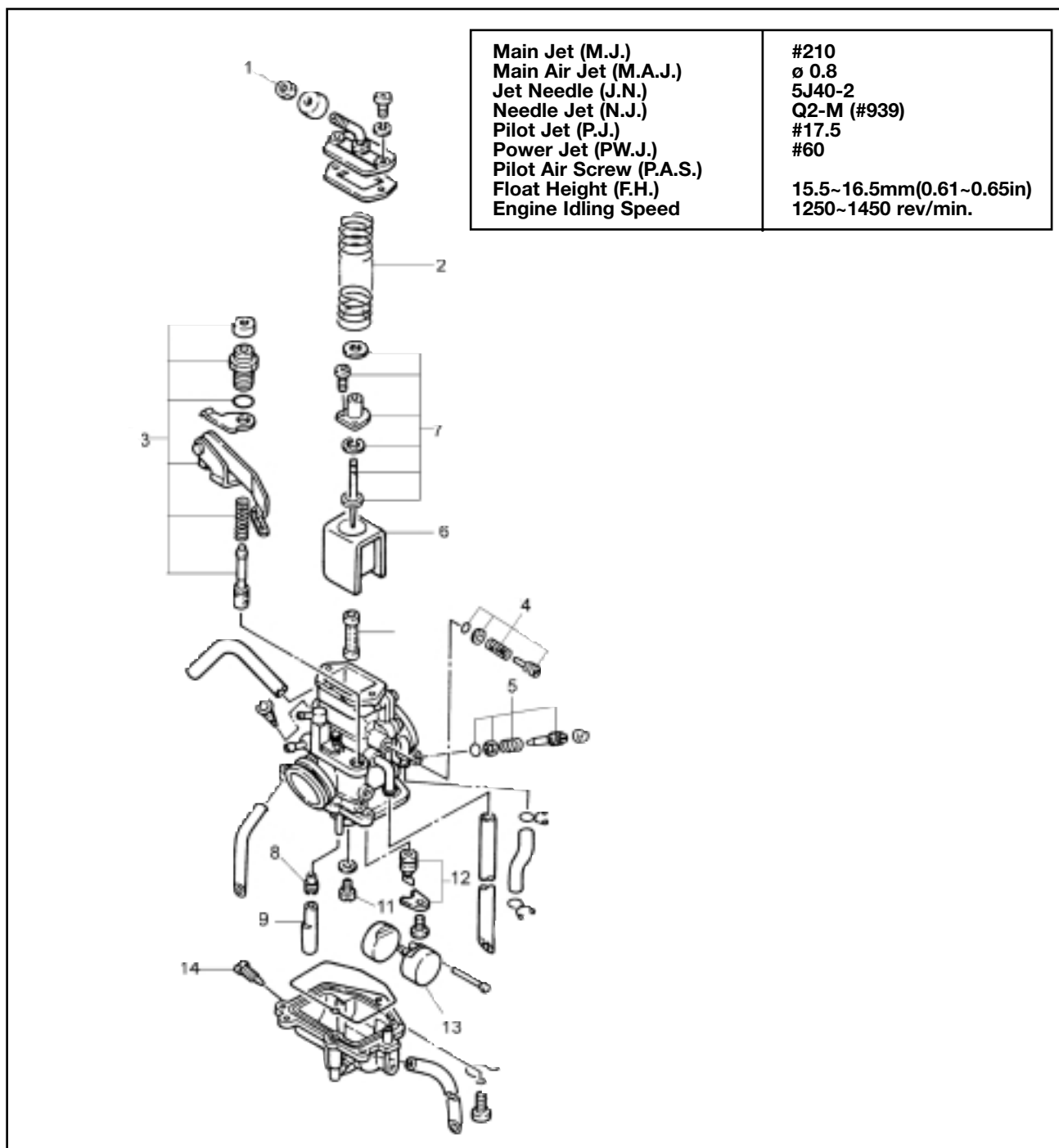



## REMOVAL

### NOTE:

The following parts can be cleaned and inspected without disassembly

- Throttle valve
- Starter plunger
- Throttle stop screw

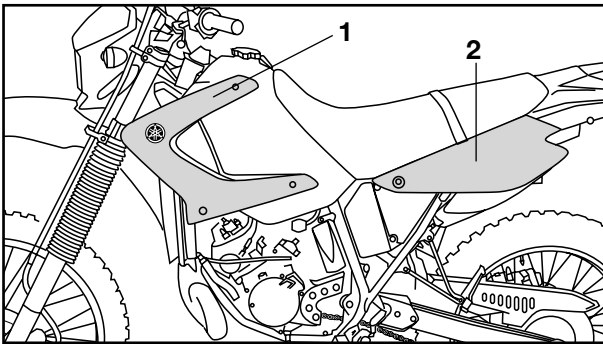

1. Remove:
  - Side cover (Left and Right) ②
  - Seat
  - Radiator cover ①

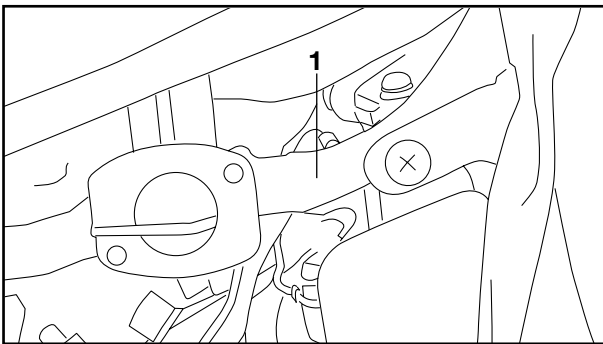

2. Turn the fuel cock to "OFF" position.
3. Disconnect:
  - Fuel hose ① (from carburetor side)

4. Remove:
  - Fuel tank

### **⚠ WARNING**

**Gasoline is highly flammable. Avoid spilling fuel over the engine when it's hot**

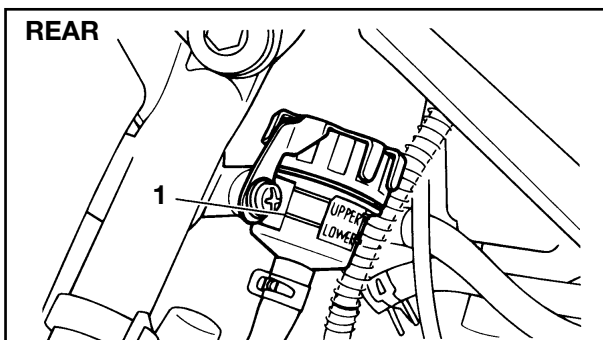

5. Disconnect:
  - Reservoir tank (Rear brake) ①
  - Y.E.I.S. system

# CARBURETOR

CARB

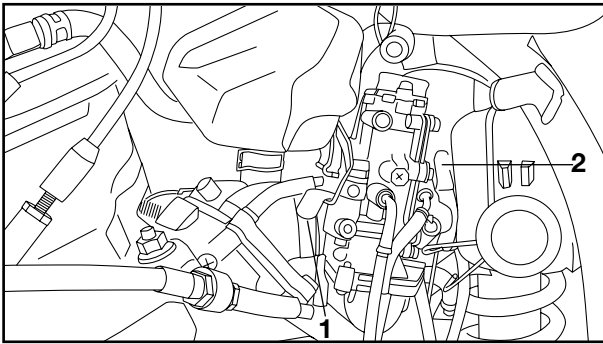

6. Disconnect:
  - Hoses
  - Oil delivery hose
  - Cooling hoses
7. Loosen:
  - Screw (carburetor joint) ①
  - Screw (air box) ②
8. Remove:
  - Carburetor top
  - Carburetor
9. Remove:
  - Cable holder
  - Throttle valve
  - Return spring

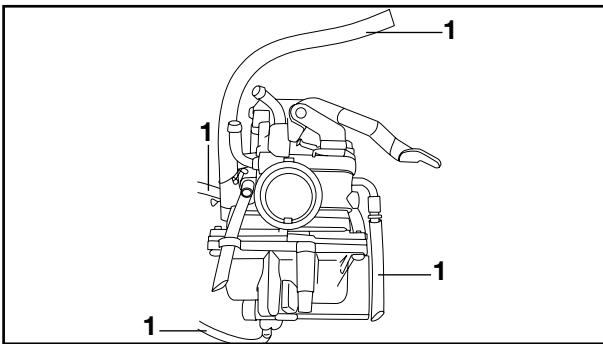

## DISASSEMBLY

1. Remove:
  - Hoses ①

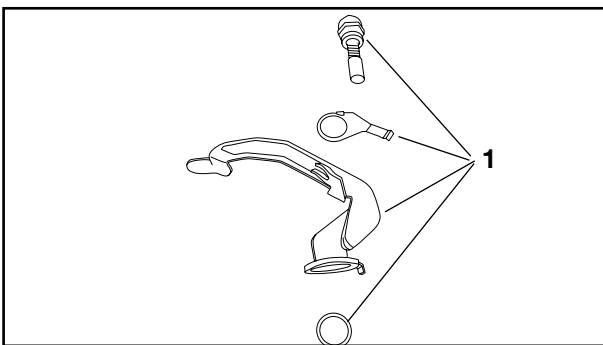

2. Remove:
  - Starter plunger assembly ①

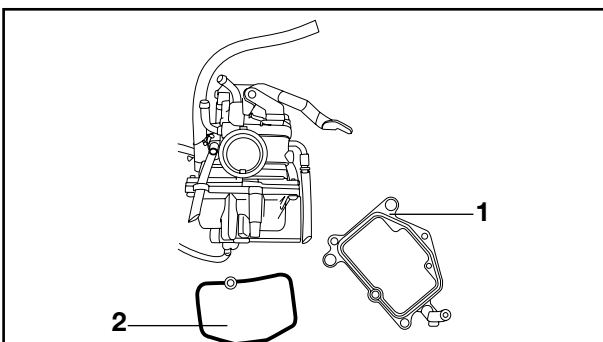

3. Remove:
  - Float chamber ①
  - Gasket float chamber ②



# CARBURETOR

CARB

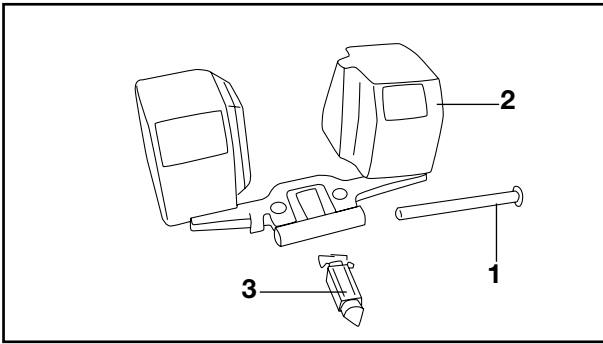

4. Remove:
- Float pin ①
  - Float ②
  - Needle valve ③

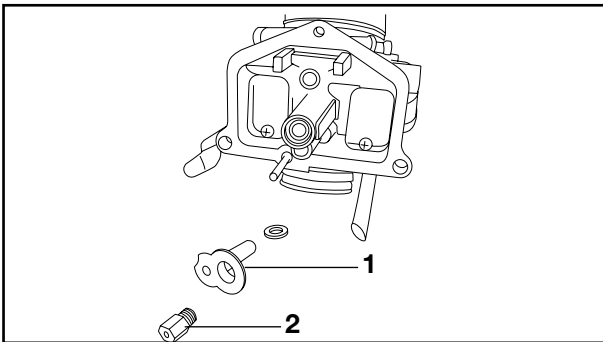

5. Remove:
- Valve seat ①
  - Main jet ②
  - Jet needle holder

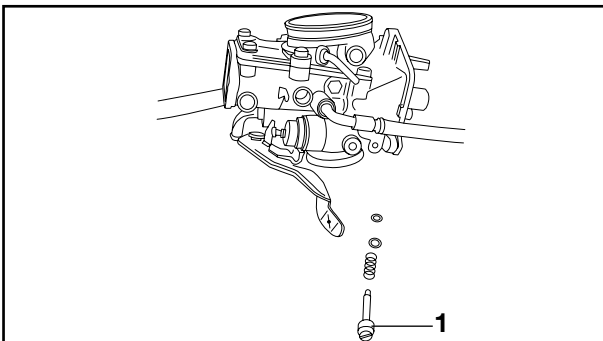

6. Remove:
- Throttle stop screw ①
  - Pilot air screw

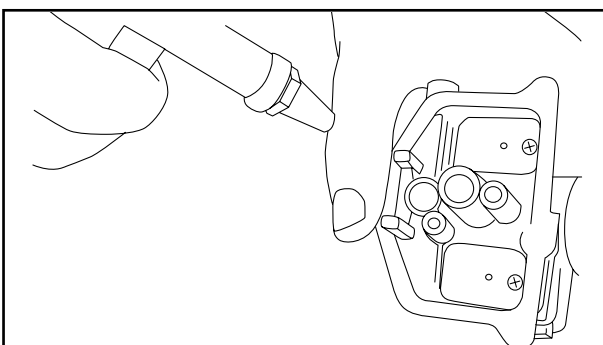

## INSPECTION

1. Inspect:
- Carburetor mixing chamber body  
Contamination → Clean

### NOTE:

Use petroleum based solvent for cleaning. Blow out all passages and jets with compressed air.

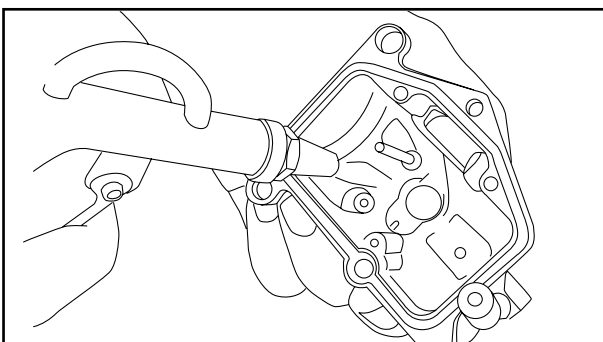

2. Inspect:
- Carburetor float chamber body  
Contamination → Clean

### NOTE:

Starter jet and all air jets are fixed type

## CARBURETOR

CARB

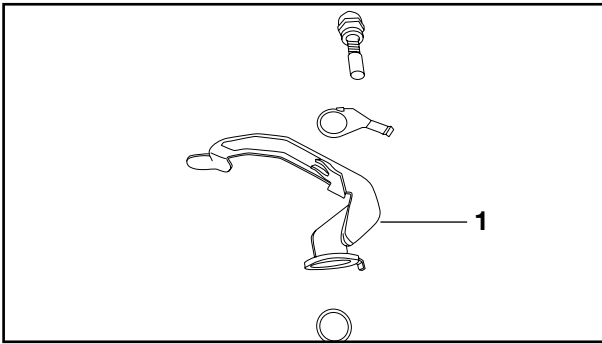

3. Inspect:
- Valve seat
  - Gasket
  - Needle valve

**NOTE:** \_\_\_\_\_

Always replace the needle valve and valve seat as a set.

\_\_\_\_\_

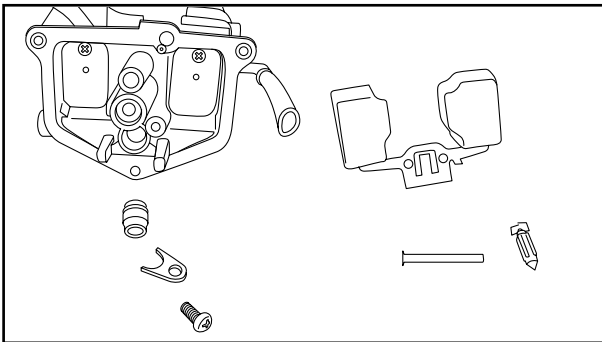

4. Inspect:
- Starter plunger ①  
Wear/Contamination → Replace
5. Check:
- Free movement  
Stick → Replace
- Insert the throttle valve into the carburetor body and check for free movement.

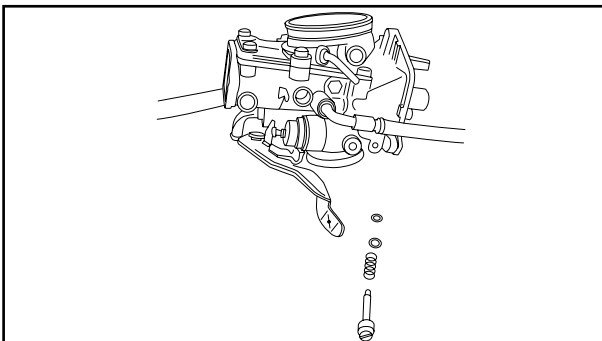

6. Inspect:
- Throttle stop screw
  - Pilot air screw
  - O-ring  
Wear/Damage → Replace

7. Inspect:
- Jet needle  
Bends/Wear → Replace

8. Inspect:
- Throttle valve  
Wear/Damage → Replace

9. Check:
- Free movement  
Stick → Replace
- Insert the throttle valve into the carburetor body, and check for free movement.

# CARBURETOR

CARB

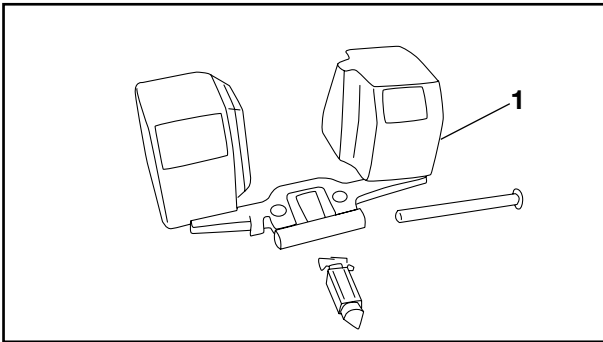

10. Inspect:

- Float ①  
Damage → Replace

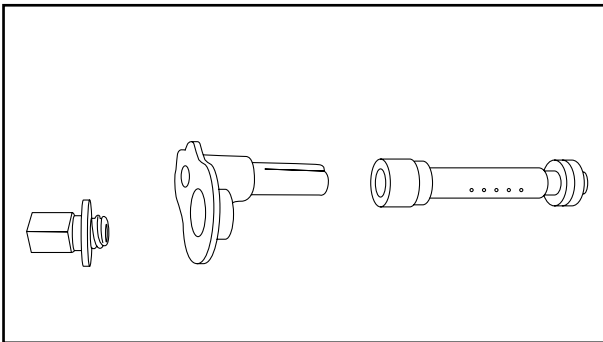

11. Inspect:

- Main jet
- Needle jet
- Pilot jet
- Contamination → Clean

**NOTE:** \_\_\_\_\_

Blow out the jets with compressed air

\_\_\_\_\_

## ASSEMBLY

Reverse the “DISASSEMBLY” procedures. Note the following points.

### CAUTION

 \_\_\_\_\_

**Before reassembling, wash all parts with clean gasoline**

\_\_\_\_\_

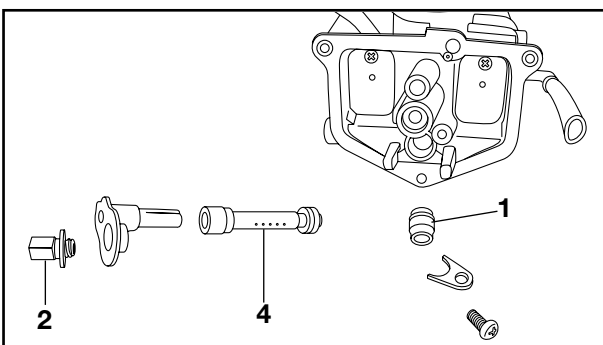

1. Tighten:

- Jet needle holder

2. Install:

- Valve seat ①
- Main jet ②
- Pilot jet ③
- Needle jet ④

**NOTE:** \_\_\_\_\_

Align the knock pin with the pin slot in the needle jet

\_\_\_\_\_

3. Measure:

- Float height @  
Out of specification → Adjust



**Float height (F.H.):**  
15.5~16.5mm (0.61~0.65in)



Measurement and adjustment steps:

- Hold the carburetor in an upside down position.
- Measure the distance from the mating surface on the float chamber (gasket removed) to the top of the float.

**CAUTION**

The float arm should be resting on the needle valve, but not compressing the needle valve.

- If the float height is not within specification, inspect the valve seat and needle valve.
- If either is worn, replace them both.
- If both are fine, adjust the float height by bending the float tang ① on the float.
- Recheck the float height.

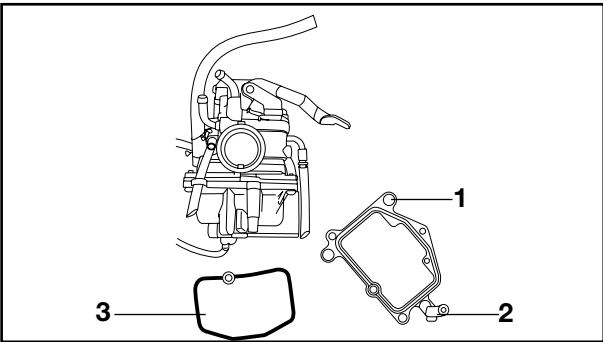
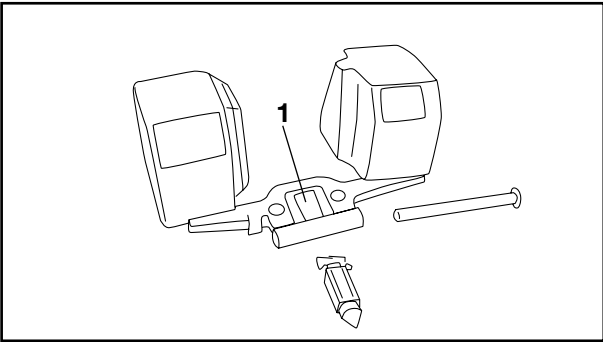

4. Install:
- Float chamber ①
  - Hose ②
  - Gasket (float chamber) ③

**⚠ WARNING**

Always use a new gasket

5. Tighten:
- Screws (Float chamber)

	<p><b>Screw (Float chamber)</b>  <b>2 Nm (0.2 m·kg; 1.4 ft·lb)</b></p>
--	--

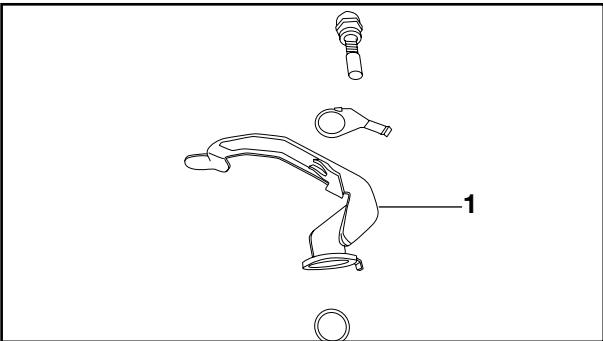

6. Install:
- Starter plunger ①

## CARBURETOR

CARB



7. Intall:
- Throttle valve

**NOTE:** \_\_\_\_\_

Align the groove of the throttle valve with the projection of the carburetor body.

---

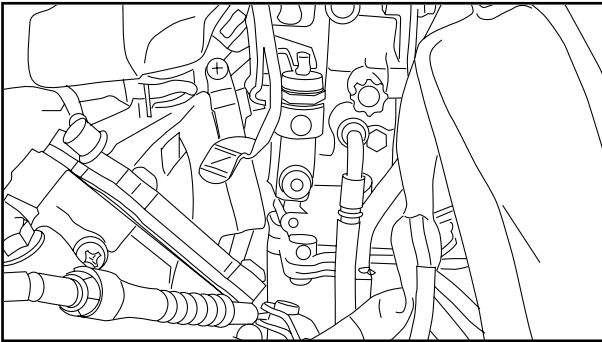

### INSTALLATION

Reverse the "REMOVAL" procedures. Note the following points.

1. Install:
- Carburetor assembly

**NOTE:** \_\_\_\_\_

Align the groove of the carburetor joint with the projection of the carburetor body.

---

2. Adjust:
- Idle speed  
Refer to the "IDLE SPEED ADJUSTMENT" section in chapter 3.



**Engine idle speed**  
1250~1450 rev/min

3. Adjust:
- Carburetor cable free play.  
Refer to the "THROTTLE CABLE FREE PLAY ADJUSTMENT" section in chapter 3.



**Throttle cable free play:**  
3-5mm 0'11-0,19in.

4. Adjust:
- Carburetor cable free play  
Refer to the "CARBURETOR CABLE FREE PLAY ADJUSTMENT" section in chapter 3.



**Carburetor cable free play:**  
1mm (0.04in.)

**ADJUSTMENT****Fuel level adjustment****1. Measure:**

- Fuel level
- Out of specification → adjust

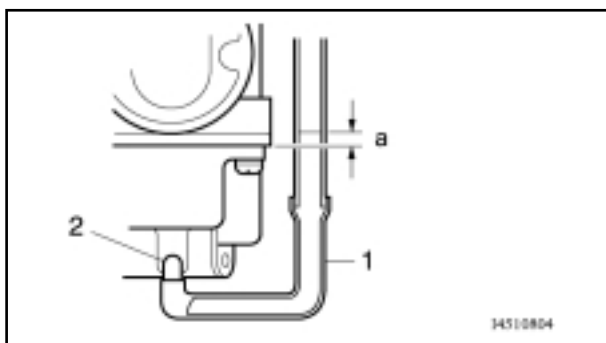
**Fuel level:****1.5~2.5mm (0.05~0.09in.)****In the middle of the Float Chamber. Below the carburetor Body edge.****Fuel level measurement and adjustment steps:**

- Place the motorcycle on a level surface.
- Use a garage jack under the engine to ensure that the carburetor is positioned vertically.
- Connect the fuel level gauge ① to the drain pipe ② .

**Fuel level gauge:  
90890-01312**

- Loosen the drain screw and warm up the engine for several minutes.
- Measure the fuel level with the gauge.
- If the level is incorrect, adjust the fuel level.
- Remove the carburetor.
- Inspect the valve seat and needle valve.
- If either is worn, replace them both.
- If both are fine, adjust the float level by bending the float tang slightly.
- Install the carburetor.
- Recheck the fuel level.



REED VALVE

- ① Reed valve assembly
- ② Reed valve
- ③ Stopper plate
- ④ Gasket
- ⑤ Carburetor joint
- ⑥ Y.E.I.S. Chamber

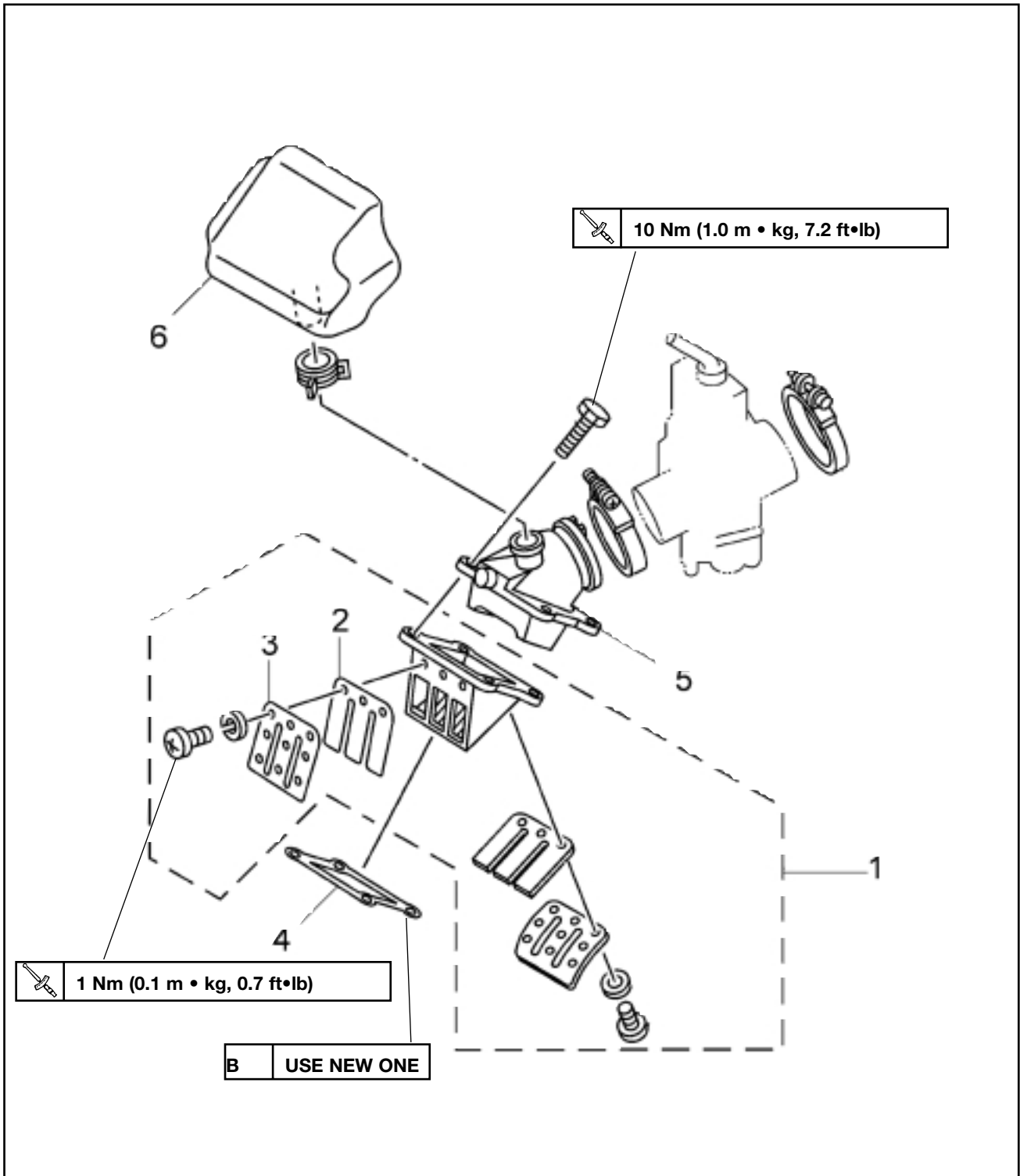



## REMOVAL

1. Remove:
  - Carburetor  
Refer to the "CARBURETOR REMOVAL" section.

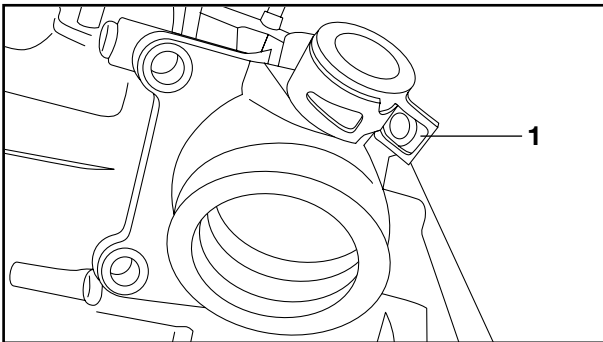

2. Remove:
  - Carburetor joint ①

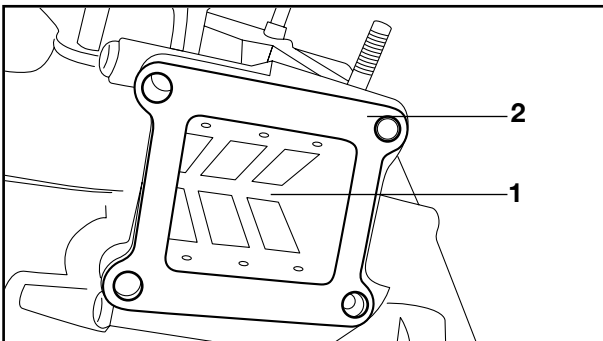

3. Remove:
  - Reed valve assembly ①
  - Gasket ②

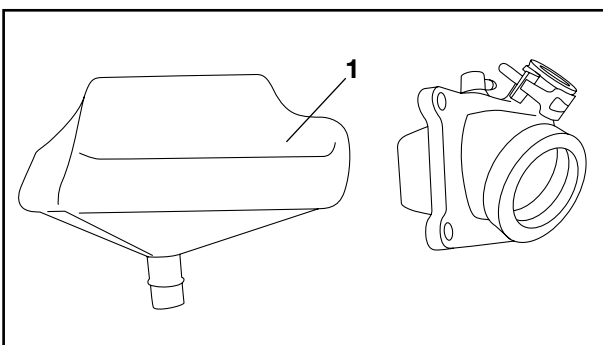

## DISASSEMBLY

1. Remove:
  - Y.E.I.S. chamber ①

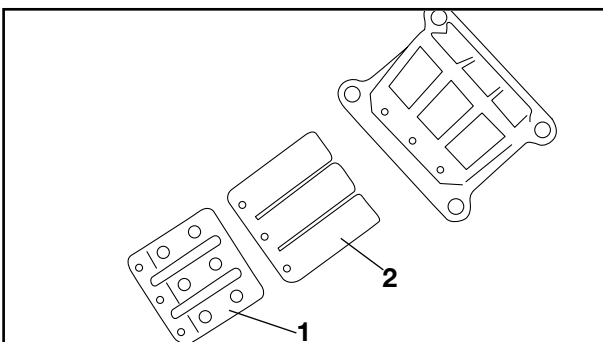

2. Remove:
  - Reed valve stopper ①
  - Reed valve ②



## REED VALVE

CARB

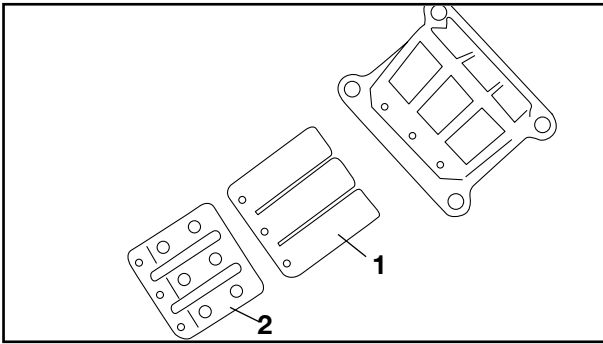

### INSPECTION

1. Inspect:
  - Reed valve ①
  - Reed valve stopper ②Cracks/Damage → Replace

2. Measure:
  - Reed valve bending limitOut of specification → Replace.



**Reed valve Bending Limit:**  
0.5mm (0.02in)

- ① Surface plate

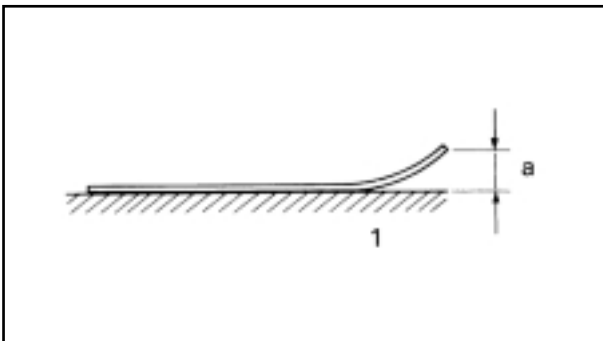

3. Measure:
  - Reed valve stopper heightOut of specification → Replace.



**Reed valve Stopper Height:**  
6.8mm (0.27in)

- ① Surface plate

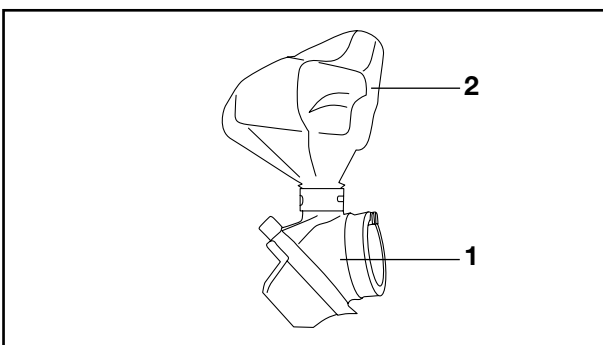

4. Inspect:
  - Carburetor joint ①
  - Y.E.I.S. chamber ②Cracks/Damage → Replace.

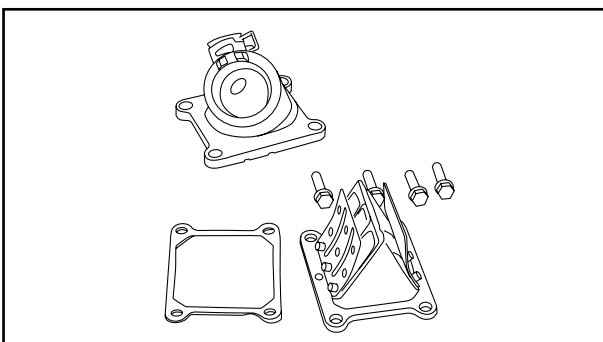

### ASSEMBLY

Reverse the "DISASSEMBLY" procedure. Note the following points.

1. Install:
  - Reed valves
  - Reed valve stoppers

**NOTE:** \_\_\_\_\_

- Place the reed valve with its concave side facing the reed valve seat.

## REED VALVE

CARB



- Fit the reed valve stopper out with the corresponding cut on the reed valve.

2. Tighten:
  - Screws (Reed valve)



**Screws (Reed valve):**  
**1 Nm (0.1 m·kg; 0.7 ft·lb) Use**  
**LOCTITE®**

### NOTE:

Tighten each screw gradually to avoid warping.

3. Install:
  - Y.E.I.S. chamber ①

### NOTE:

The arrow on the Y.E.I.S. chamber must point forward.

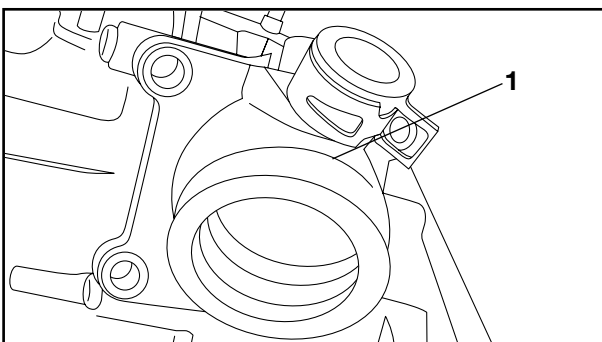
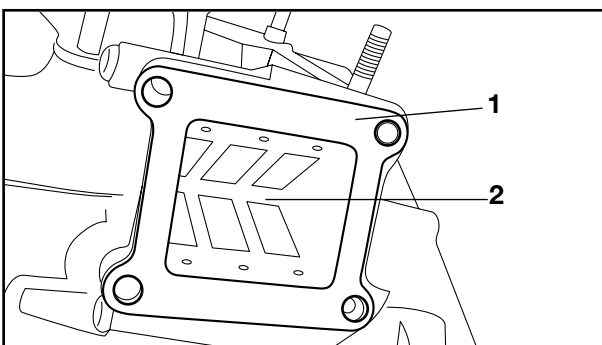
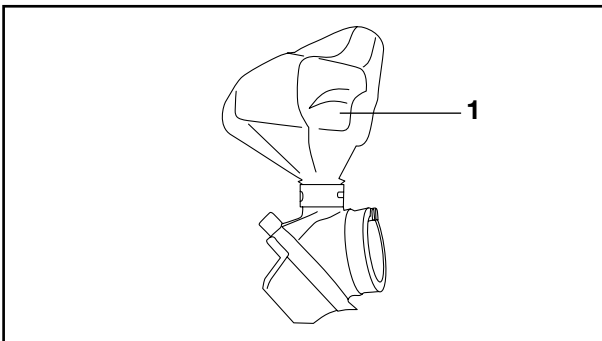

## INSTALLATION

Reverse the “REMOVAL” procedure. Note the following points.

1. Install:
  - Gasket (New) ①
  - Reed valve assembly ②

### ⚠ WARNING

**A damaged gasket may cause the engine revs to accelerate. Always use a new gasket.**

2. Install:
  - Carburetor joint ①



**Bolt (Carburetor joint):**  
**10 Nm (1.0 m·kg; 7.2 ft·lb)**

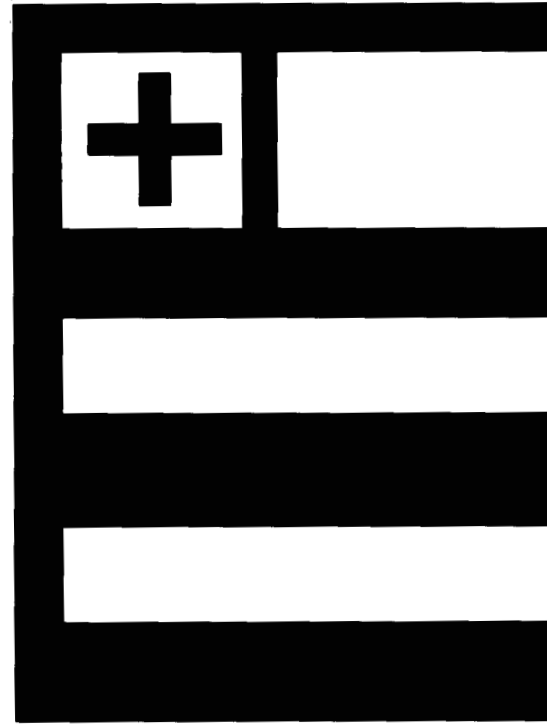

**ELEC**



88

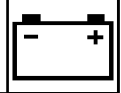

---

## CHAPTER 8 ELECTRICAL SYSTEM

<b>DT125RE CIRCUIT DIAGRAM</b> .....	8-1
COLOR CODE .....	8-1
<b>ELECTRICAL COMPONENTS</b> .....	8-2
CHECKING SWITCH CONTINUITY .....	8-4
CHECKING THE SWITCHES .....	8-5
<b>IGNITION SYSTEM</b> .....	8-6
CIRCUIT DIAGRAM .....	8-6
IGNITION CONTROL CIRCUIT OPERATION .....	8-6
TROUBLESHOOTING .....	8-8
<b>CHARGING SYSTEM</b> .....	8-14
CIRCUIT DIAGRAM .....	8-14
TROUBLESHOOTING .....	8-15
<b>LIGHTING SYSTEM</b> .....	8-16
CIRCUIT DIAGRAM .....	8-16
TROUBLESHOOTING .....	8-17
<b>SIGNALING SYSTEM</b> .....	8-26
CIRCUIT DIAGRAM .....	8-26
TROUBLESHOOTING .....	8-27
<b>COOLING SYSTEM</b> .....	8-38
CIRCUIT DIAGRAM .....	8-38
TROUBLESHOOTING .....	8-39
<b>YAMAHA POER VALVE SYSTEM</b> .....	8-42
CIRCUIT DIAGRAM .....	8-42
TROUBLESHOOTING .....	8-43
<b>METER ASSEMBLY</b> .....	8-46
REMOVAL .....	8-47
INSTALLATION .....	8-48

# DT125RE CIRCUIT DIAGRAM

ELEC

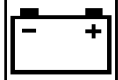

## ELECTRICAL

### DT125RE CIRCUIT DIAGRAM

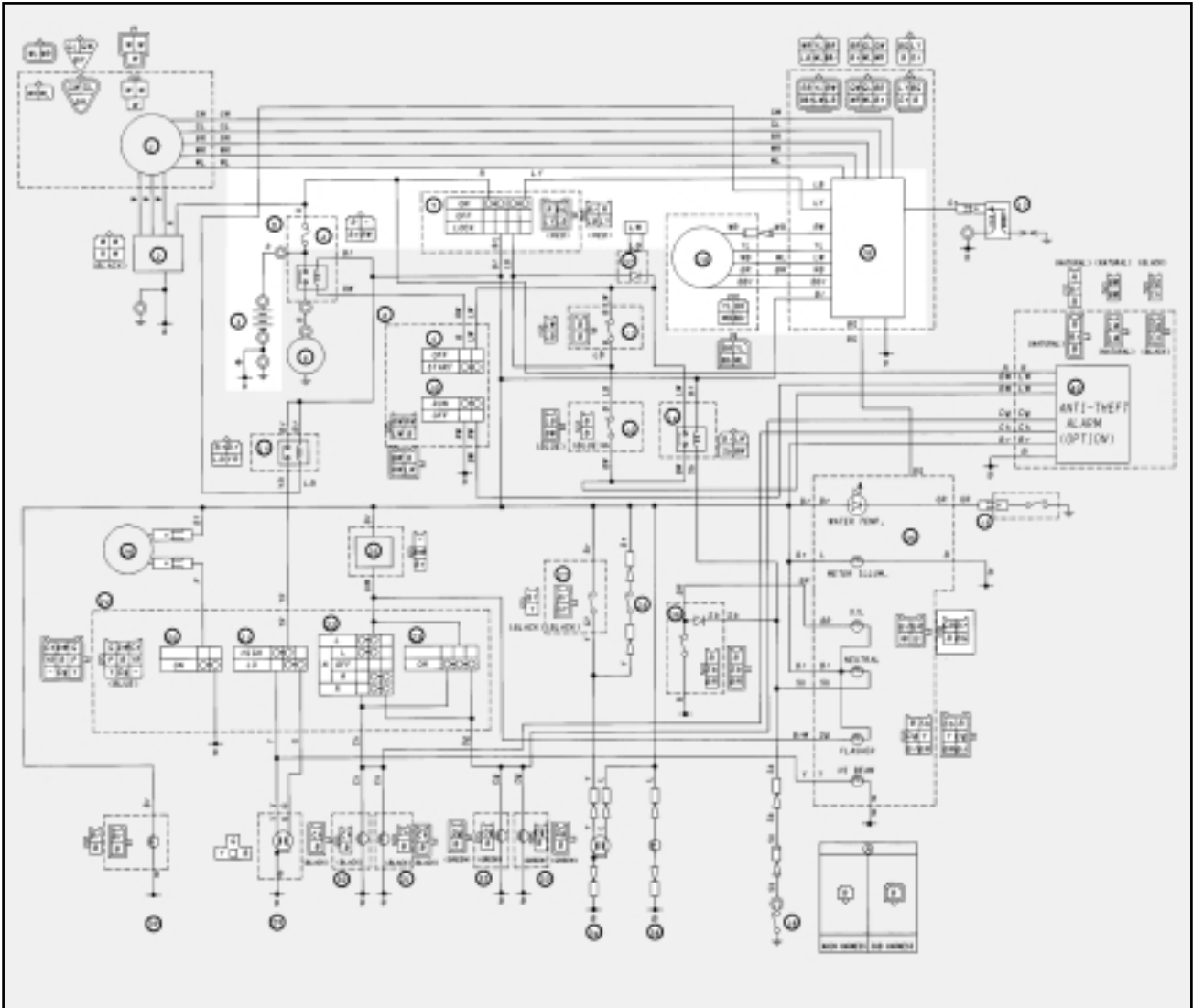

B	Black	Ch	Chocolate	W/R	White/Red
R	Red	Dg	Dark green	W/L	White/Blue
O	Orange	Sb	Sky blue	Y/R	Yellow/Red
L	Blue	Br	Brown	G/R	Green/Red
P	Pink	L/Y	Blue/Yellow	G/Y	Green/Yellow
Y	Yellow	B/Y	Black/Yellow	G/W	Green/White
G	Green	B/W	Black/White	Br/W	Brown/White
W	White	B/R	black/Red	L7R	Blue/Red

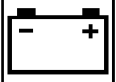

## ELECTRICAL COMPONENTS(1)

- ① CDI Unit
- ② Servomotor
- ③ Battery
- ④ Fuse
- ⑤ Neutral switch
- ⑥ Thermo unit
- ⑦ Rectifier/Regulator
- ⑧ Ignition coil
- ⑨ Main switch

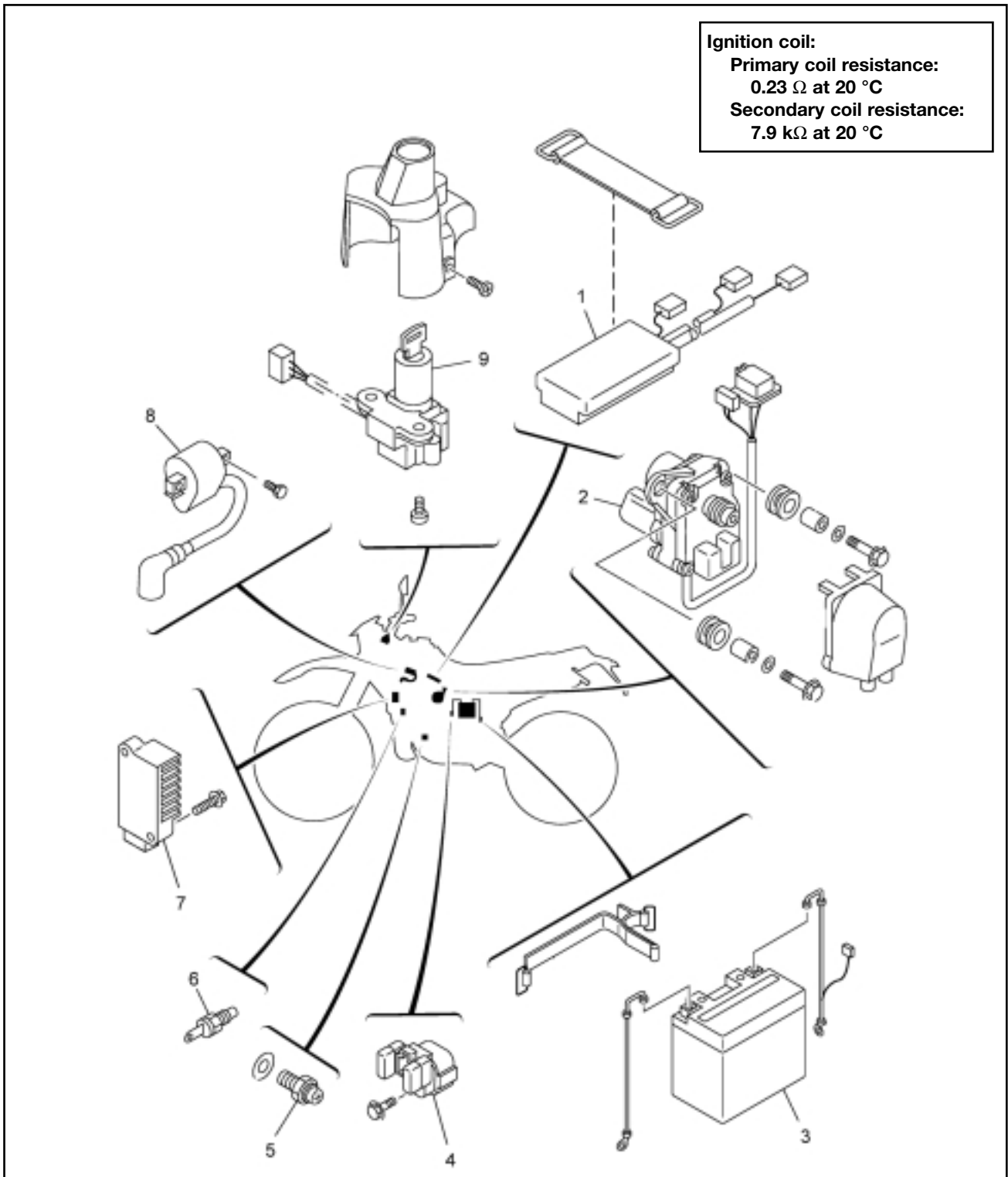

ELECTRICAL COMPONENTS(2)

- ① Flasher relay
- ② Conductor wire
- ③ Rectifier 2
- ④ Oil gauge
- ⑤ Sidestand switch
- ⑥ Brake switch
- ⑦ Relay
- ⑧ Horn

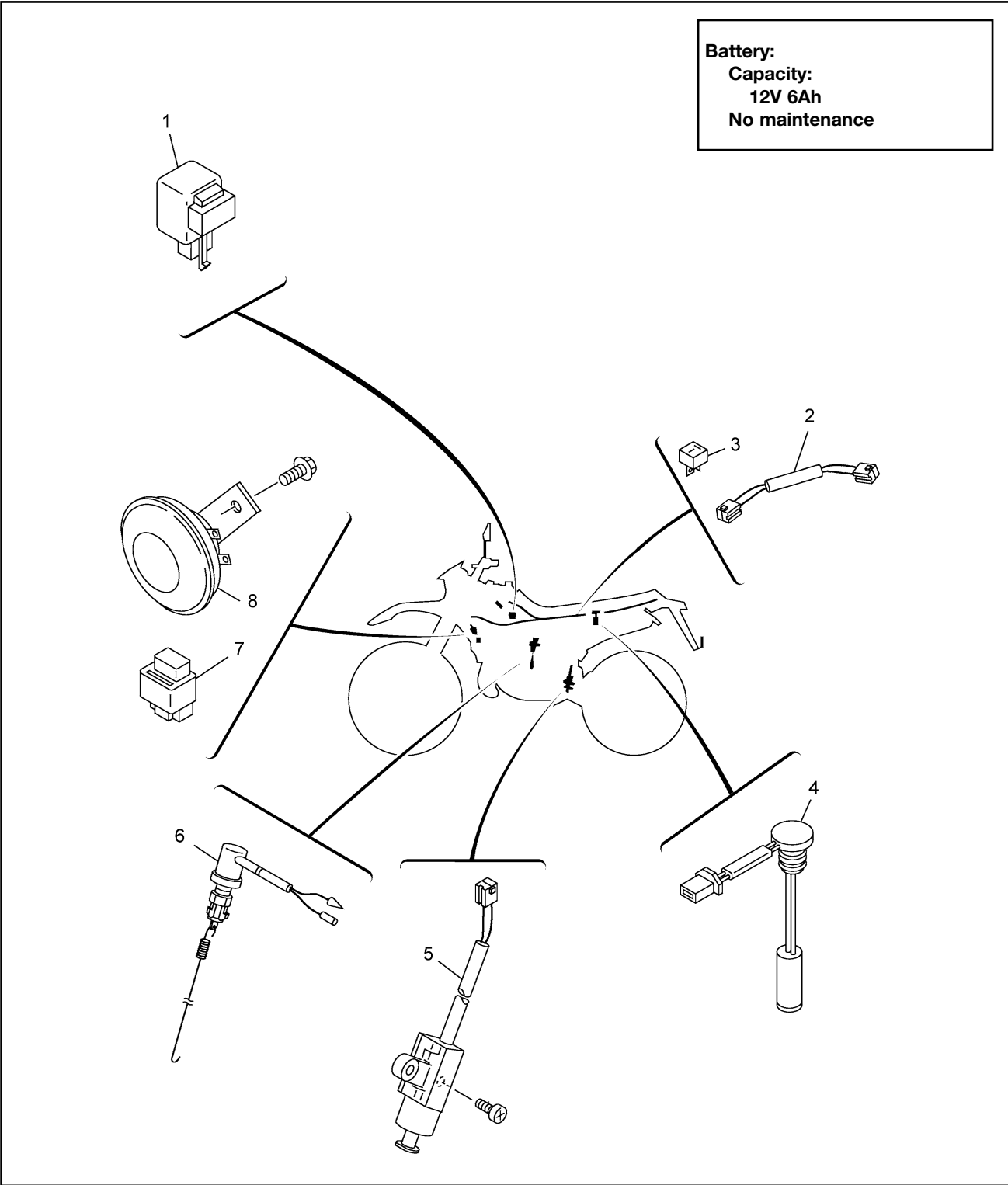





EAS00730

## CHECKING SWITCH CONTINUTY

Check each switch for continuity with the pocket tester. If the continuity reading is incorrect, check the wiring connections and if necessary, replace the switch.

**CAUTION:** \_\_\_\_\_

**Never insert the tester probes into the coupler terminal slots. Always insert the probes from the opposite end of the coupler, taking care not to loosen or damage the leads.**

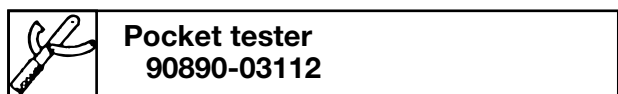

**NOTE:** \_\_\_\_\_

- Before checking for continuity, set the pocket tester to “0” and to the “Ωx1” range.
- When checking for continuity, switch back and forth between the switch positions a few times.

The terminal connections for switches (e.g., main switch, engine stop switch) are shown in an illustration similar to the one on the left. The switch positions (a) are shown in the far left column and the switch lead colors (b) are shown in the top row in the switch illustration.

**NOTE:** \_\_\_\_\_

“○—○” indicates a continuity of electricity between switch terminals (i.e., a closed circuit at the respective switch position).

**The example illustration on the left shows that:**

There is continuity between black and black/white when the switch is set to “ON”.  
There is continuity between red and brown when the switch is set to “ON”.

		b				
		GY	Br	R	B	B/W
a	LOCK					
	OPEN					
	OFF					
	CHECK	○		○		
	ON			○	○	○

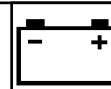

EAS00731

## CHECKING THE SWITCHES

Check each switch for damage or wear, proper connections, and also for continuity between the terminals. Refer to "CHECKING SWITCH CONTINUITY".

Damage/wear → Repair or replace.

Improperly connected → Properly connect.

Incorrect continuity reading → Replace the switch.

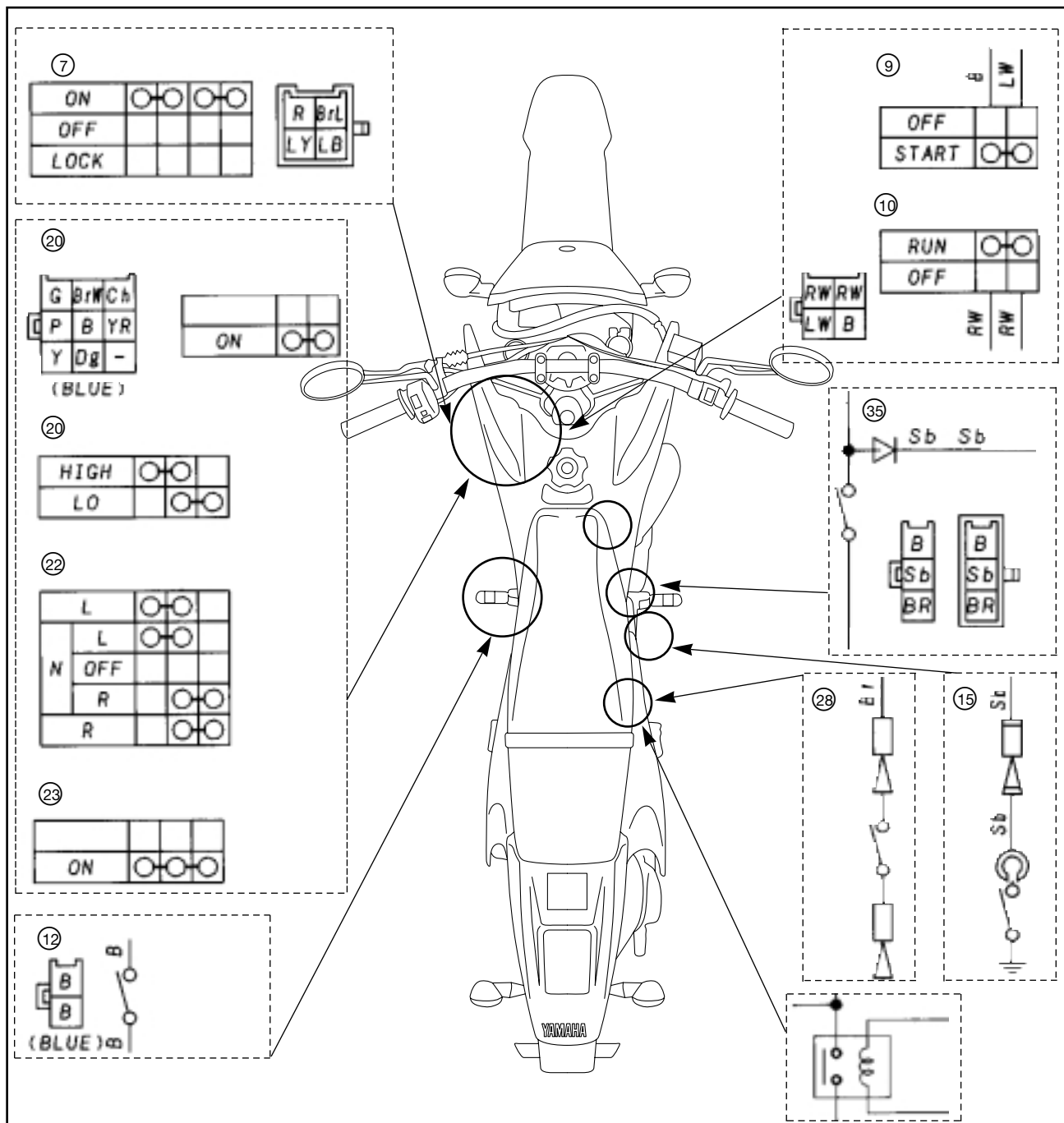

- ⑦ Main switch
- ②④ Left handle switch
- ⑫ Side stand switch
- ⑧ Right handle switch

- ③⑤ Oil Level gauge
- ⑮ Neutral switch
- ⑳ Rear stop switch
- ④ Fuse

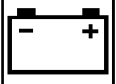

# IGNITION SYSTEM

The circuit diagram shows the ignition system.

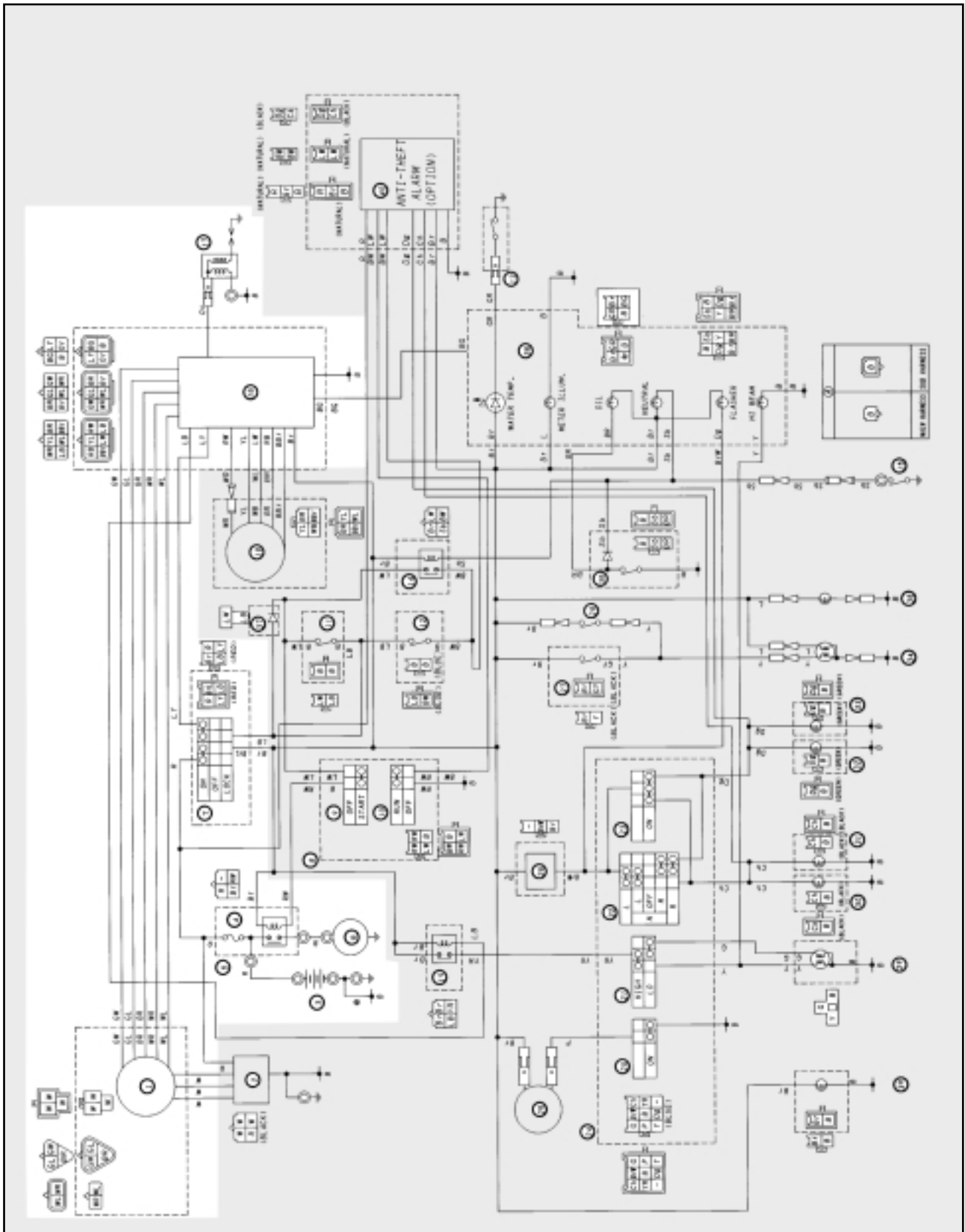

## IGNITION SYSTEM

ELEC

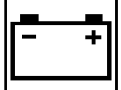

**NOTE:**

For the color codes see the electric diagram

- ① Magneto CDI
- ③ Battery
- ④ Fuse
- ⑤ Starter relay
- ⑥ Starting engine
- ⑦ Main switch
- ⑧ C.D.I.
- ⑨ Ignition coil

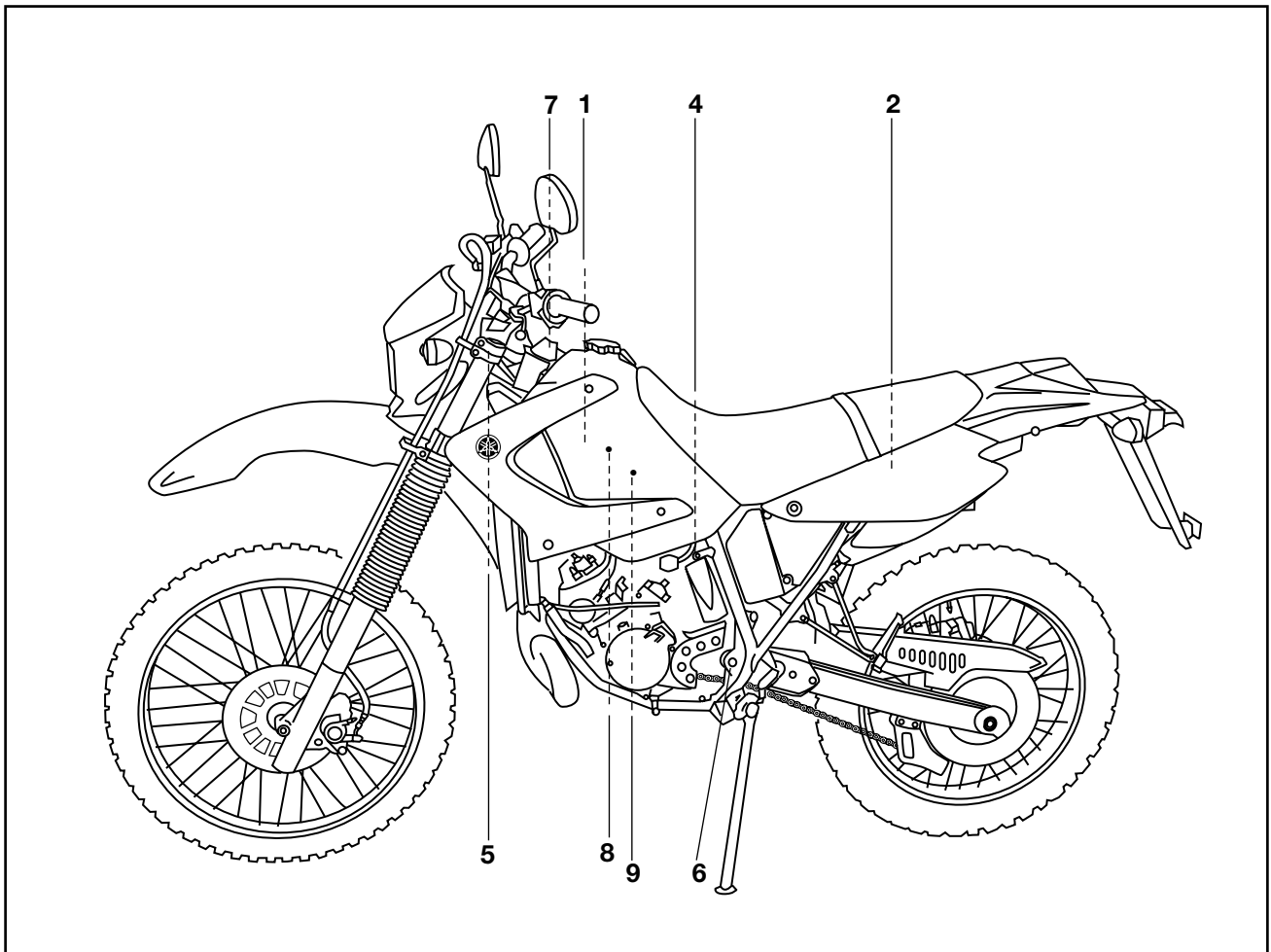

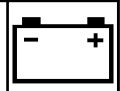

EAS00736

## TROUBLESHOOTING

**The ignition system fails to operate (no spark or intermittent spark).**

Check:

1. Main and ignition fuses
2. Battery
3. Spark plug
4. Ignition spark gap
5. Spark plug cap resistance
6. Ignition coil resistance
7. Main switch
8. Engine stop switch
9. Neutral switch
10. Sidestand switch
11. Pickup coil resistance
12. Wiring connections (of the entire ignition system)

**NOTE:**

- Before troubleshooting, remove the following part(s):
  1. Side covers (right and left)
  2. Seat
  3. Fuel tank
  4. Headlight cover
  5. Headlight unit
- Troubleshoot with the following special tool(s).



**Ignition checker**  
90890-06754  
**Pocket tester**  
90890-03112

EAS00740

### 1. Spark plug

- Check the condition of the spark plug.
- Check the spark plug type.
- Measure the spark plug gap.  
Refer to "CHECKING THE SPARK PLUG" in chapter 3.



**Standard spark plug**  
**BR8HS (NGK)**  
**Spark plug gap**  
**0.6 ~ 0.7 mm**

- Is the spark plug in good condition, is it of the correct type, and is its gap within specification?



YES



NO

Re-gap or replace the spark plug.

EAS00742

### 2. Ignition spark gap

- Disconnect the spark plug cap from the spark plug.
- Connect the ignition checker ① as shown.

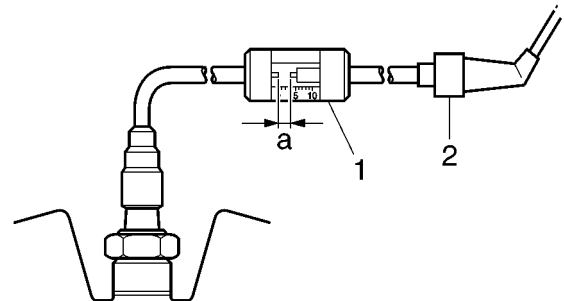

### ② Spark plug cap

- Set the main switch to "ON".
- Measure the ignition spark gap @.
- Crank the engine by pushing the starter switch and gradually increase the spark gap until a misfire occurs.



**Minimum ignition spark gap**  
**6 mm (0.24 in)**

- Is there a spark and is the spark gap within specification?



YES



NO

The ignition system is OK.

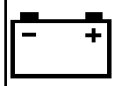

EAS00744

**3. Spark plug cap resistance**

- Remove the spark plug cap from the spark plug lead.
- Connect the pocket tester (“ $\Omega \times 1k$ ” range) to the spark plug cap as shown.
- Measure the spark plug cap resistance.

**Spark plug cap resistance**  
 $5K\Omega$  at  $20^{\circ}C$  ( $68^{\circ}C$ )

- Is the spark plug cap OK?

↓ YES

↓ NO

Replace the spark plug cap.

EAS00746

**4. Ignition coil resistance (Orange) from the wireharness**

- Disconnect the ignition coil connectors from the ignition coil terminals.
- Connect the pocket tester ( $\Omega \times 1$ ) to the ignition coil as shown.

**Positive tester probe → Orange terminal**  
**Negative tester probe → Ignition coil base**

- Measure the primary coil resistance.

**Primary coil resistance**  
 $0.23 \pm 20^{\circ}C$  ( $68^{\circ}C$ )

- Connect the pocket tester ( $\Omega \times 1k$ ) to the ignition coil as shown.

**Negative tester probe → Ignition coil base ①**  
**Positive tester probe → spark plug lead ②**

- Measure the secondary coil resistance.

**Secondary coil resistance**  
 $7.9 \pm k\Omega$   $20^{\circ}C$  ( $68^{\circ}C$ )

- Is the ignition coil OK?

↓ YES

↓ NO

Replace the ignition coil.

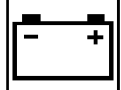

EAS00749

EAS00750

**5. Main switch**

- Disconnect the main switch coupler and lead from the wireharness (red).
- Connect the pocket tester ( $\Omega$  100) to the main switch.

**Positive tester probe → red Lead**

**Negative tester probe → brown-blue Terminal**

- Turn the main switch to "ON" and "OFF".
- Check the main switch for continuity.

Switch position	Good condition	Bad condition		
		X	X	○
OFF	○	X	X	○
ON	X	○	X	○
PARK	X	○	X	○

○: Continuity      X: No continuity

↓ YES

↓ NO

Replace the main switch.

**6. "ENGINE STOP" switch**

- Disconnect the "ENGINE STOP" switch leads from the wireharness.
- Connect the pocket tester ( $\Omega$  100) to the "ENGINE STOP" switch.

**Positive tester probe → black/white Lead**

**Negative tester probe → Black Lead**

- Turn the "ENGINE STOP" switch to "OFF" and "RUN".
- Check the "ENGINE STOP" switch for continuity.

Switch position	Good condition	Bad condition		
		○	X	○
OFF	X	○	X	○
ON	○	X	X	○

○: Continuity      X: No continuity

• Is the engine stop switch OK?

↓ YES

↓ NO

Replace the hand-lebar switch.

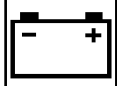

EAS00748

**7. source coil resistance**

- Disconnect the CDI magneto coupler ① from the wireharness.
- Connect the pocket tester ( $\Omega$  100) to the source coil.

**Positive tester probe → Green/white ② Terminal**  
**Negative tester probe → Black/red ③ Terminal**

- Measure the source coil resistance.

**Source coil resistance**  
 192~288  $\Omega$  at 20°C (68°F)

- Is the source coil resistance OK?

↓ YES

↓ NO

Replace the source coil.

**8. Pickup coil resistance**

- Disconnect the CDI magneto coupler from the wire harness.
- Connect the pocket tester ( $\Omega$  100) to the pickup coil.

**Positive tester probe → white/blue**  
**Negative tester probe → white/red**

- Measure the pickup coil resistance.

**Pickup coil resistance**  
 280 ~ 420  $\Omega$  at 20°C (68°F)  
 (between white/red and white/blue)

- Is the pickup coil OK?

↓ YES

↓ NO

Replace the pickup coil.

EAS00754

**9. Wiring**

- Check the entire ignition system's wiring. Refer to "CIRCUIT DIAGRAM".
- Is the ignition system's wiring properly connected and without defects?

↓ YES

↓ NO

Replace the DC-CDI unit.

Properly connect or repair the ignition system's wiring.



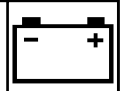

EAS00752

## Procedure (2)

1. Sidestand switch

- Disconnect the sidestand switch leads from the wireharness.
- Connect the pocket tester ( $\Omega 100$ ) to the sidestand switch.

**Positive tester probe → blue/white Terminal**  
**Negative tester probe → blue/black Terminal**

- Move the sidestand to up position and down position.
- Check the sidestand switch for continuity.

Switch position	Good condition	Bad condition		
UP	○	X	X	○
DOWN	X	○	X	○

○: Continuity      X: No continuity

- Is the sidestand switch OK?

↓ YES

↓ NO

Replace the sidestand switch.

EAS00751

2. Neutral switch

- Disconnect the CDI magneto coupler from the wireharness.
- Connect the pocket tester ( $\Omega 100$ ) to the neutral switch lead.

**Positive tester probe → sky blue lead**  
**Negative tester probe → Frame ground**

- Shift the transmission in neutral and gear.
- Check the neutral switch for continuity.

Switch position	Good condition	Bad condition		
NEUTRAL	○	X	X	○
GEAR	X	○	X	○

○: Continuity      X: No continuity

- Is the sidestand switch OK?

↓ YES

↓ NO

Replace the sidestand switch.

EAS00754

3. Wiring

- Check the entire ignition system's wiring. Refer to "CIRCUIT DIAGRAM".
- Is the ignition system's wiring properly connected and without defects?

↓ YES

Replace the DC-CDI unit.

↓ NO

Properly connect or repair the ignition system's wiring.



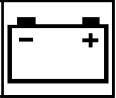

EAS00773

## CHARGING SYSTEM

### CIRCUIT DIAGRAM

- ① Generator
- ② Rectifier/regulator
- ③
- ④ Battery
- ⑤ Main fuse

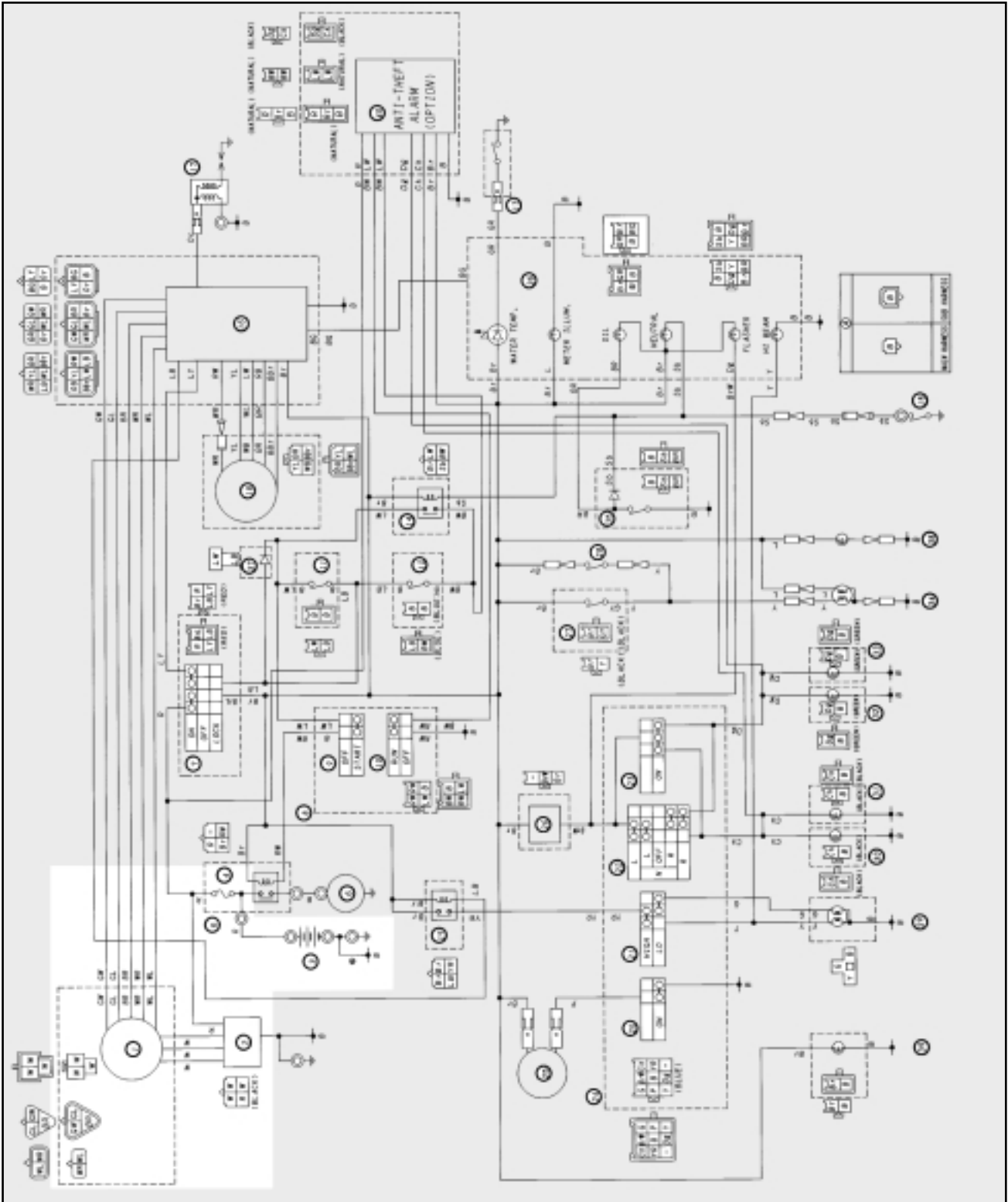

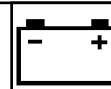

EAS00774

### TROUBLESHOOTING

**The battery is not being charged.**

1. main fuse
2. battery
3. charging voltage
4. charging coil resistance
5. wiring connections  
(of the entire charging system)

**NOTE:** \_\_\_\_\_

- Before troubleshooting, remove the following part(s):
  1. Side covers (Left and right)
  2. Seat
  3. Fuel tank
  4. Radiator cover
- Troubleshoot with the following special tool(s).

	<b>Engine tachometer</b> 90890-03113 <b>Pocket tester</b> 90890-03112
--	--

1. Fuse <ul style="list-style-type: none"> <li>• Remove the fuse.</li> <li>• Connect the pocket tester (<math>\Omega</math> 100) to the fuse.</li> <li>• Check the fuse for continuity.</li> <li>• Is the fuse OK?</li> </ul>
--

↓ YES

↓ NO

Replace the fuse.

2. Battery <ul style="list-style-type: none"> <li>• Check the battery condition. Refer to the "BATTERY INSPECTION" section in CHAPTER 3.</li> <li>• Is the battery OK?</li> </ul>
--

↓ YES

↓ NO

Replace the battery.

EAS00775

### 3. Charging voltage

- Connect the engine tachometer to the spark plug lead.
- Connect the pocket tester (DC 20 V) to the battery.

**Positive tester probe → positive battery terminal**  
**Negative tester probe → negative battery terminal**

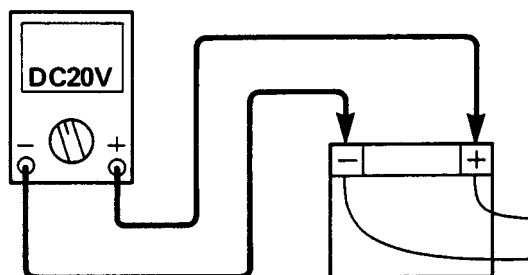

- Start the engine and let it run at approximately 3000 r/min.
- Measure the charging voltage.



**Charging voltage**  
**14 V at 5000 r/min**

**NOTE:** \_\_\_\_\_

Make sure the battery is fully charged.

- Is the charging voltage within specification?

↓ YES

↓ NO

The charging circuit is OK.

EAS00779

### 4. Wiring

- Check the wiring connections of the entire charging system. Refer to "CIRCUIT DIAGRAM".
- Is the charging system's wiring properly connected and without defects?

↓ YES

↓ NO

Replace the rectifier/regulator.

Properly connect or repair the charging system's wiring.

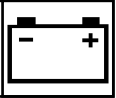

EAS00780

## LIGHTING SYSTEM CIRCUIT DIAGRAM

- ① Magento-CDI
- ③ Rectifier/regulator
- ⑦ Main switch
- ⑳ "LIGHTS" switch
- ㉑ Headlight
- ㉒ Tail light
- ㉓ Meter lights

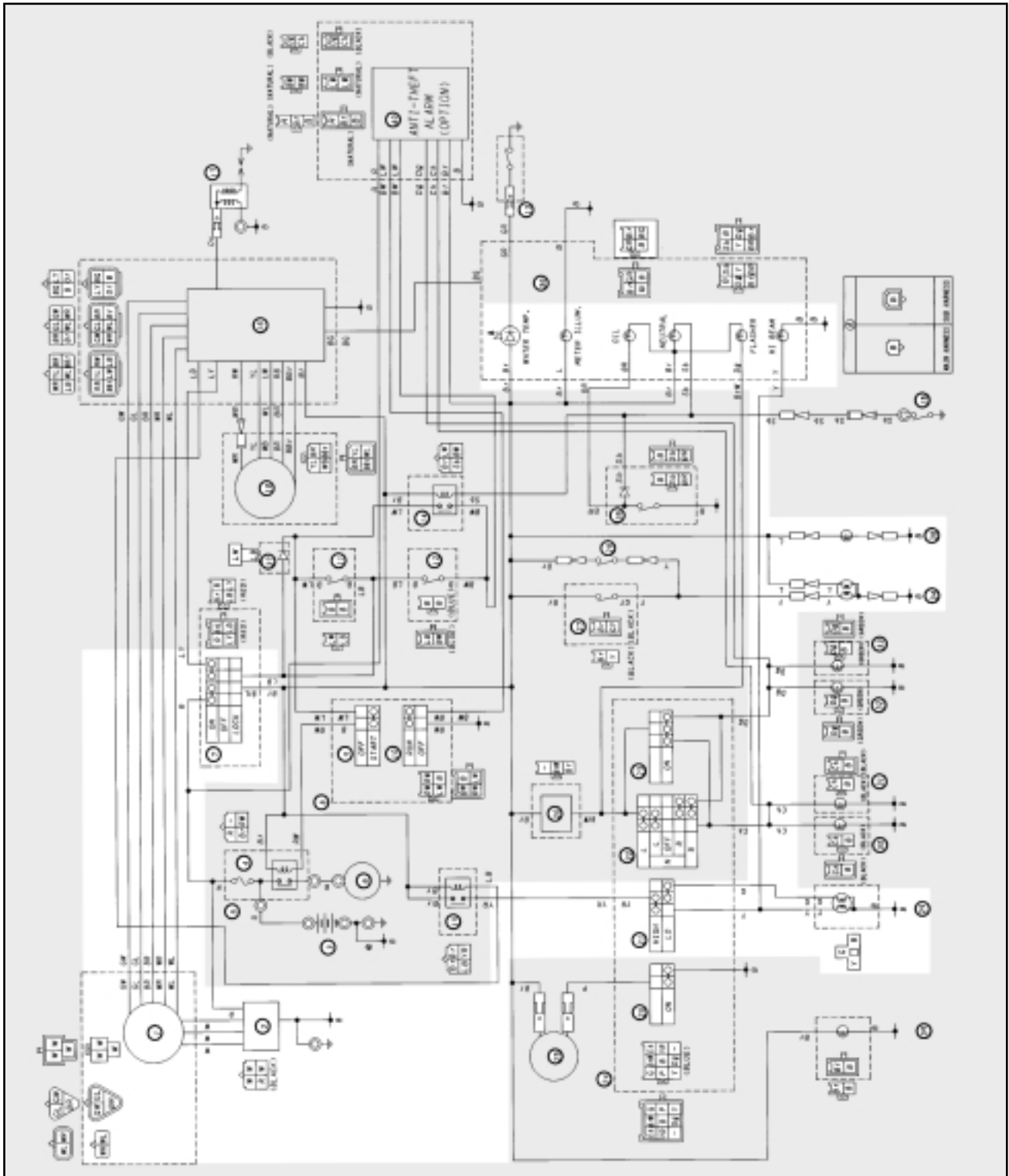

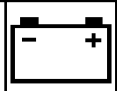

EAS00781

### TROUBLESHOOTING

**Any of the following fail to light: headlight, high beam indicator light, taillight, auxiliary light or meter light.**

Check:

1. Headlight bulb/"HI BEAM" indicator light bulb
2. Headlight bulb socket/"HI BEAM"
3. "LIGHTS" (dimmer) switch
4. "Lights" switch
5. Lighting voltage
6. Lighting coil resistance
7. wiring connection  
(of the entire lighting system)

#### NOTE:

- Before troubleshooting, remove the following part(s):
  1. Sidecovers (left and right)
  2. Seat
  3. Fuel tank
  4. Headlight cover
  5. Headlight unit
- Troubleshoot with the following special tool(s).



**Pocket tester**  
90890-03112  
**Inductive Tachometer:**  
90890-03113

#### 1. Bulb

- Remove the bulb.  
Refer to the "HEADLIGHT BULB REPLACEMENT" section in the chapter 3.
- Connect the pocket tester ( $\Omega$  100) to the bulbs terminals.

**Positive tester probe → terminal ①**  
**Negative tester probe → terminal ②**

**Positive tester probe → terminal ①**  
**Negative tester probe → terminal ③**

**A**

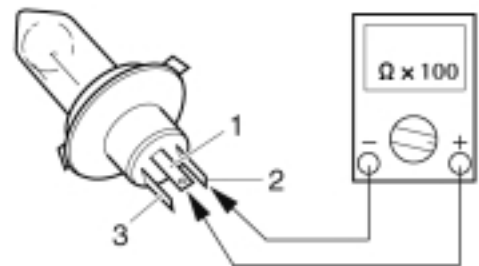

**B**

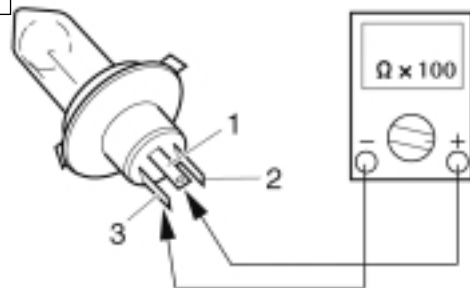

A. Headlight bulb

B. "HI BEAM" indicator light bulb

- Check the bulb for continuity.
- Is the bulb OK?

↓ YES

↓ NO

Replace the bulb.

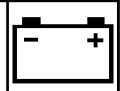

2. Bulb socket

- Disconnect the bulb socket leads from the wire harness.
- Install the bulb to the bulb socket.
- Connect the pocket tester ( $\Omega$  100) to the bulbs terminals.

**Positive tester probe → Yellow lead**  
**Negative tester probe → Black lead**

**Positive tester probe → Green lead**  
**Negative tester probe → Black lead**

A. Headlight bulb socket  
 B. "HI BEAM" indicator light bulb socket

- Check the bulb socket for continuity.
- Is the bulb socket OK?

↓ YES

↓ NO

Replace the bulb socket.

3. "LIGHTS" (Dimmer) switch

- Connect the pocket tester ( $\Omega$  100) to the bulbs terminals.

When turning "LIGHTS" (Dimmer) switch to "HI".

**Positive tester probe → Yellow lead**  
**Negative tester probe → Black lead**

When turning "LIGHTS" (Dimmer) switch to "LO".

**Positive tester probe → Green lead**  
**Negative tester probe → Black lead**

- Turn the "LIGHTS" (Dimmer) switch to the "HI" and "LO".
- Check the "LIGHTS" (Dimmer) for continuity.

Switch position	Good condition	Bad condition		
"HI"	○	X	○	X
"LO"	○	○	X	X

○: Continuity      X: No continuity

- Is the "LIGHTS" (Dimmer) OK?

↓ YES

↓ NO

Replace handlebar switch (left).

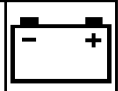

EAS00787

4. Lighting voltage.

- Turn (Dimmer) switch to “LO”.
- Connect the pocket tester (DC 20 V) to the battery.

**Positive tester probe → Green ② terminal**  
**Negative tester probe → Black ③ terminal**

- Connect the inductive tachometer to the spark plug lead.
- Start the engine and check the lightning voltage.

- Is the “LIGHTS” switch OK?

↓ YES

↓ NO

Replace handlebar switch (left).

5. Wiring

- Check the entire lighting system’s wiring. Refer to “CIRCUIT DIAGRAM”.
- Is the lighting system’s wiring properly connected and without defects?

↓ YES

↓ NO

Check the condition of each of the lighting system’s circuits. Refer to “CHECKING THE LIGHTING SYSTEM”.

Properly connect or repair the lighting system’s wiring.



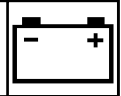

## TROUBLESHOOTING

**Meter light does not come on**

Check:

1. Meter light bulb
2. Meter light bulb socket
3. Wiring connection  
(of the entire lighting system)

**NOTE:** \_\_\_\_\_

- Before troubleshooting, remove the following part(s):
  1. Sidecovers (left and right)
  2. Seat
  3. Fuel tank
  4. Headlight cover
  5. Headlight unit
- Troubleshoot with the following special tool(s).



**Pocket tester**  
90890-03112  
**Inductive Tachometer:**  
90890-03113

**1. Bulb**

- Remove the bulb.  
Refer to the "METER ASSEMBLY" section.
- Connect the pocket tester ( $\Omega$  1) to the bulbs terminals.

**Positive tester probe** → terminal ①  
**Negative tester probe** → terminal ②

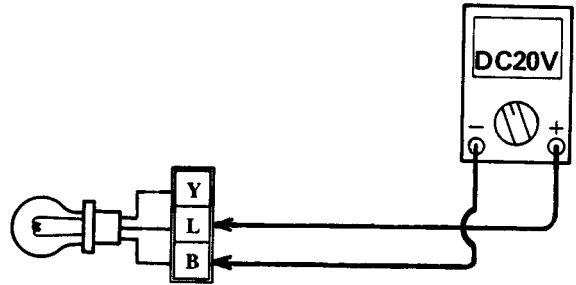

- Check the bulb for continuity.
- Is the bulb OK?

↓ YES

↓ NO

Replace the bulb.

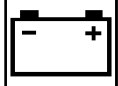

2. Bulb socket

- Disconnect the bulb socket lead and coupler from the wire harness.
- Install the bulb to the bulb socket.
- Connect the pocket tester ( $\Omega$  1) to the bulbs socket lead end and coupler.

**Positive tester probe → Blue ① lead**  
**Negative tester probe → Black ② Terminal**

- Check the bulb socket for continuity.
- Is the bulb socket OK?

↓ YES

↓ NO

Replace the bulb socket.

EAS00787

3. Wiring

- Check the entire lighting system's wiring. Refer to "CIRCUIT DIAGRAM".
- Is the lighting system's wiring properly connected and without defects?

↓ YES

↓ NO

Check the condition of each of the lighting system's circuits. Refer to "CHECKING THE LIGHTING SYSTEM".

Properly connect or repair the lighting system's wiring.

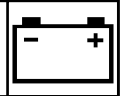

## TROUBLESHOOTING

### Tail light/Auxiliary light do not come on

Check:

1. Tail/Brake light bulb/Auxiliary light bulb
2. Tail light bulb socket/Auxiliary light
3. Main switch
4. Wiring connection  
(of the entire lighting system)

**NOTE:** \_\_\_\_\_

- Before troubleshooting, remove the following part(s):
  1. Sidecovers (left and right)
  2. Seat
  3. Fuel tank
  4. Headlight cover
  5. Headlight unit
- Troubleshoot with the following special tool(s).



**Pocket tester**  
90890-03112  
**Inductive Tachometer:**  
90890-03113

### 1. Bulb

- Remove the bulb.
- Connect the pocket tester ( $\Omega \times 1$ ) to the bulb terminals.

**Positive tester probe** → terminal ①  
**Negative tester probe** → terminal ②

**Positive tester probe** → terminal ①  
**Negative tester probe** → terminal ②

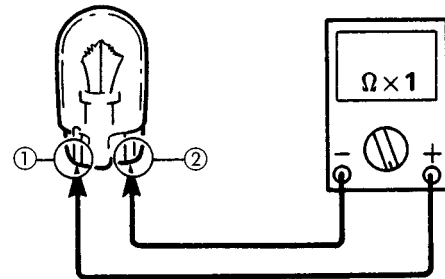
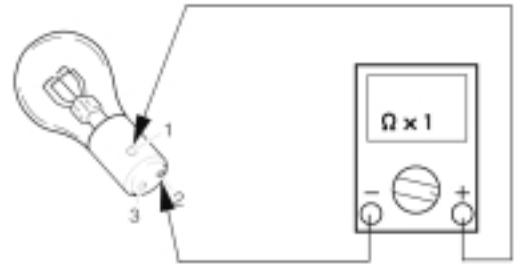

- A. Tail/Brake bulb  
B. Auxiliary light bulb

- Check the bulb for continuity.
- Is the bulb OK?

↓ YES

↓ NO

Replace the bulb.

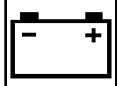

**2. Bulb socket**

- Disconnect the bulb socket and leads from the wire harness.
- Install the bulb to the bulb socket.
- Connect the pocket tester ( $\Omega$  1) to the bulbs socket lead end and coupler.

**A**  
**Positive tester probe** → Blue ① **Terminal**  
**Negative tester probe** → Black ② **Terminal**

**B**  
**Positive tester probe** → Blue/Red ③ **Lead**  
**Negative tester probe** → Black ④ **Lead**

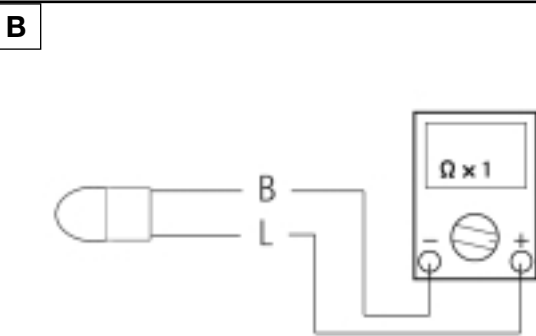
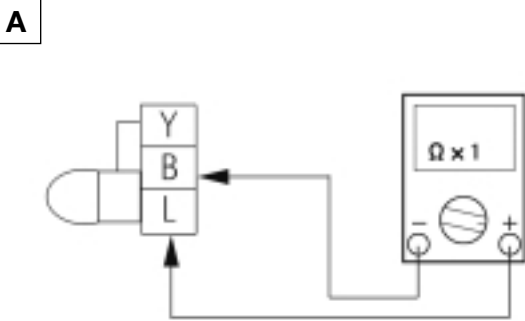

- Check the bulb socket for continuity.
- Is the bulb socket OK?

↓ YES

↓ NO

Replace the bulb socket.

**3. Main switch**

- Disconnect the main switch coupler from the wire harness.

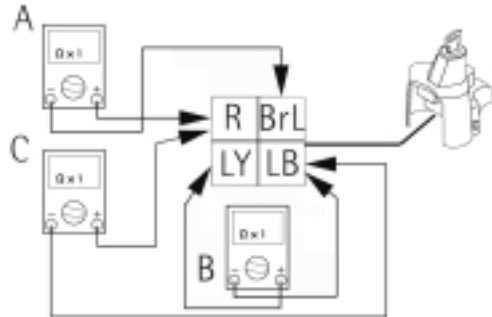

- Connect the pocket tester ( $\Omega$  1) to the main switch.
- Check the main switch for continuity.

**A**  
**Positive tester probe** → Red Lead  
**Negative tester probe** → Brown-blue Lead

Switch position	Good condition	Bad condition		
ON	○	X	X	○
OFF	X	○	X	○

**B**  
**Positive tester probe** → Yellow-blue Lead  
**Negative tester probe** → Blue-Black Lead

Switch position	Good condition	Bad condition		
ON	○	X	X	○
OFF	X	○	X	○

**C**  
**Positive tester probe** → Red Lead  
**Negative tester probe** → Blue-Black Lead

Switch position	Good condition	Bad condition		
P	○	X	X	○
OFF	X	○	X	○

○:Continuity

X: No continuity

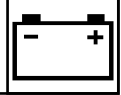

EAS00787

## 4. Wiring

- Check the entire lighting system's wiring. Refer to "CIRCUIT DIAGRAM".
- Is the lighting system's wiring properly connected and without defects?

↓ YES

↓ NO

Check the condition of each of the lighting system's circuits. Refer to "CHECKING THE LIGHTING SYSTEM".

Properly connect or repair the lighting system's wiring.



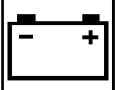

EAS00793

**SIGNALING SYSTEM**

**CIRCUIT DIAGRAM**

- ⑦ Main switch
- ④ Main fuse
- ③ Battery
- ⑮ Neutral switch
- ③⑤ Engine oil level switch
- ③⑦ Diode
- ②⑩ Horn switch
- ②⑤ Horn
- ②② Turn switch
- ②⑥ Turn signal relay
- ③④ Tail/brake light
- ②⑧ Rear brake light switch
- ②⑦ Front brake light switch

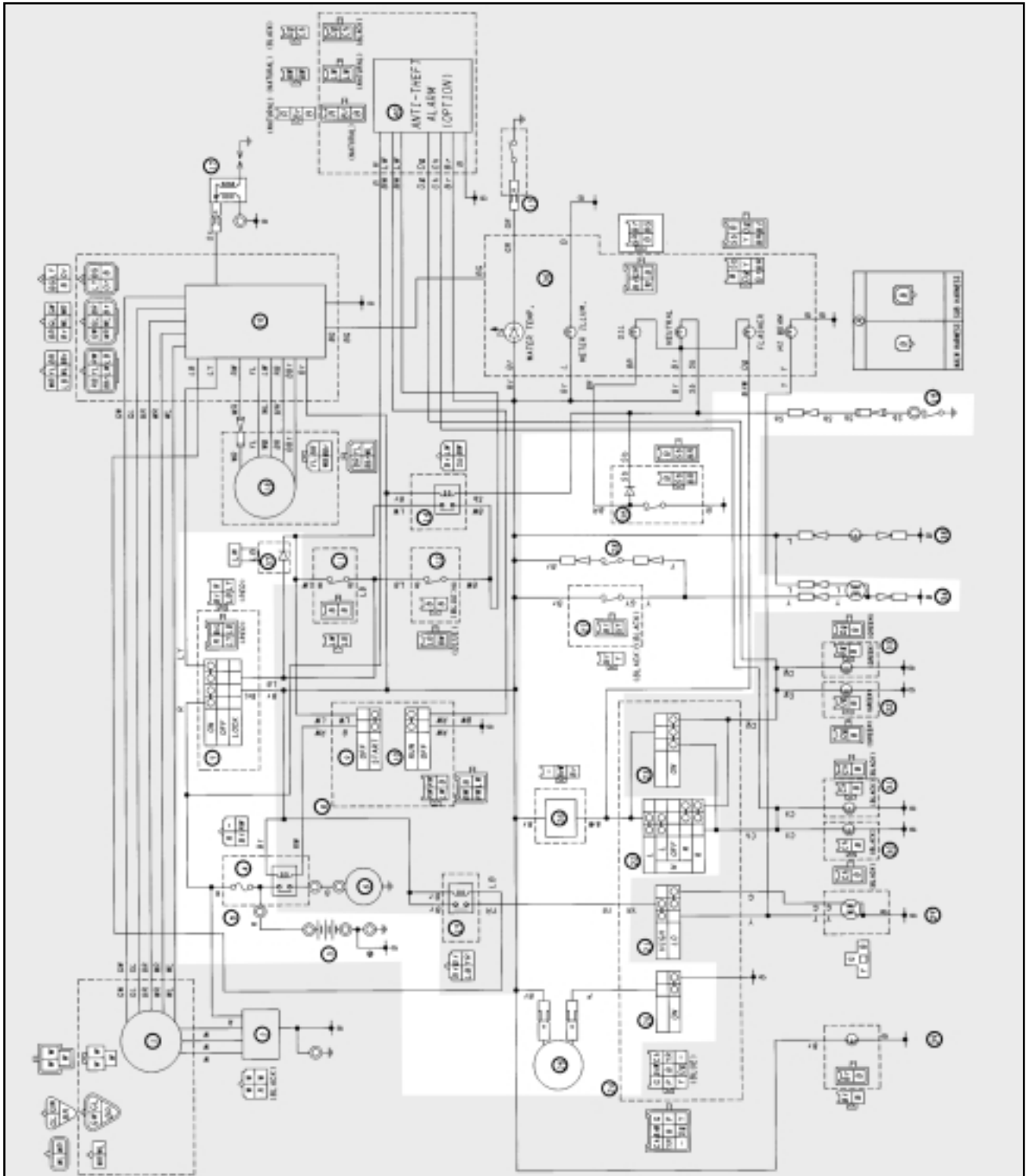

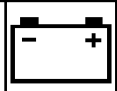

EAS00794

**TROUBLESHOOTING**

**Any of the following fail to light: flasher light, brake light or an indicator light do not come on and the horn fails to sound.**

Check:

1. Fuse
2. battery
3. main switch
4. wiring connections  
(of the entire signaling system)

**NOTE:**

- Before troubleshooting, remove the following part(s):
  1. Side covers (left and right)
  2. Seat
  3. Fuel tank
  4. Headlight cover
  5. Headlight unit
- Troubleshoot with the following special tool(s).

	<p><b>Pocket tester</b> 90890-03112</p>
--	---

1. Fuse
<ul style="list-style-type: none"> <li>• Remove the fuse.</li> <li>• Connect the pocket tester (<math>\Omega</math> 1) to the fuse.</li> <li>• Check the fuse for continuity.</li> </ul>

2. Battery
<ul style="list-style-type: none"> <li>• Check the battery condition. Refer to the "BATTERY INSPECTION" section in chapter 3.</li> </ul>

3. Main switch
<ul style="list-style-type: none"> <li>• Disconnect the main switch coupler from the wire harness.</li> <li>• Connect the pocket tester (<math>\Omega</math> 1) to the main switch.</li> </ul>

**Tester (+) Lead → Red ① Lead**  
**Tester (-) Lead → Brown-Blue ② Lead**

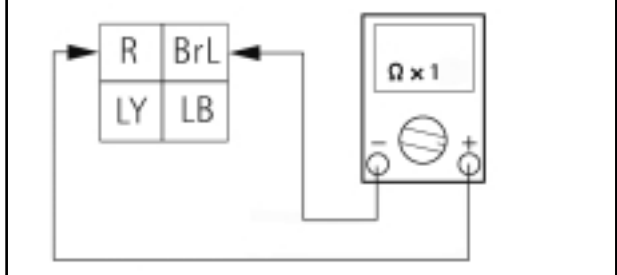

- Turn the main switch to "ON", "OFF" and "PARK".
- Check the main switch for continuity.

Switch position	Good condition	Bad condition		
ON	○	X	X	○
OFF	X	○	X	○
PARK	X	○	X	○

○:Continuity      X: No continuity

EAS00795

4. Wiring
<ul style="list-style-type: none"> <li>• Check the entire signal system's wiring. Refer to "CIRCUIT DIAGRAM".</li> <li>• Is the signaling system's wiring properly connected and without defects?</li> </ul>

↓ YES

↓ NO

Check the condition of each of the signaling system's circuits. Refer to "CHECKING THE SIGNALING SYSTEM".

Properly connect or repair the signaling system's wiring.



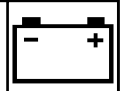

**FLASHER LIGHT DOES NOT BRINK**

**1. Bulb**

- Remove the bulb.
- Connect the pocket tester ( $\Omega 1$ ) to the bulb terminals.

**Positive tester probe → terminal ①**  
**Negative tester probe → terminal ②**

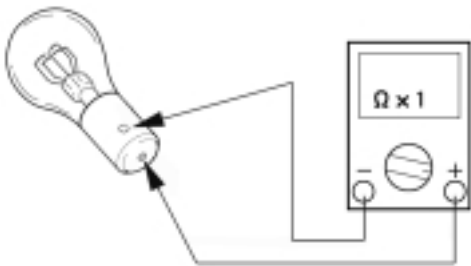

- Check the bulb for continuity.

↓ YES

↓ NO

Replace the bulb

**2. Bulb socket**

- Install the bulb to the sockets.
- Disconnect the flasher light leads ① from the wire harness.
- Connect the pocket tester ( $\Omega 1$ ) to the flasher light leads.

**When checking right flasher light:**  
**Positive tester probe → Dark Green ① Lead**  
**Negative tester probe → Black ③ Lead**

**When checking left flasher light:**  
**Positive tester probe → Chocolate ② Lead**  
**Negative tester probe → Black ③ Lead**

**A FRONT**

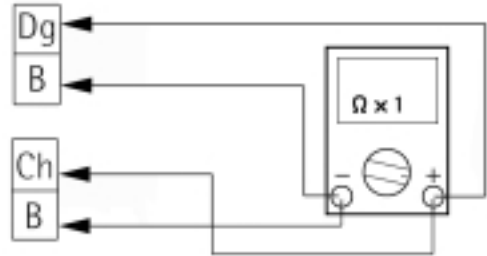

**B REAR**

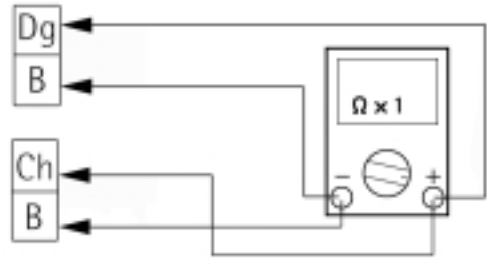

- Check the bulb socket for continuity.
- Is the bulb socket OK?

↓ YES

↓ NO

Replace the bulb socket.

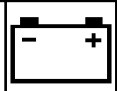

3. "TURN" switch

- Disconnect the "TURN" switch (Left hand-lebar switch) coupler ① from the wire harness.
- Connect the pocket tester ( $\Omega$  1) to the "TURN" switch.

**When turning "TURN" switch to "R":**  
**Positive tester probe → Brown/White ② Lead**  
**Negative tester probe → Dark green ③ Lead**

**When turning "TURN" switch to "L":**  
**Positive tester probe → Brown/White ② Lead**  
**Negative tester probe → Chocolate ④ Lead**

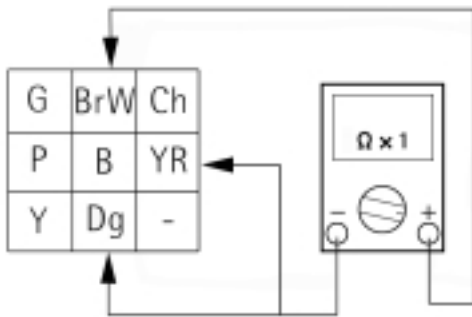

- Turn the "TURN" switch to the "R" and "L".
- Check the "TURN" switch for continuity.

Switch position	Good condition	Bad condition		
R	○	X	X	○
L	○	○	X	X

○: Continuity      X: No continuity

• Is the "TURN" switch OK?

↓ YES
↓ NO

Replace the "TURN" switch.

4. Voltage

- Disconnect the flasher relay ① coupler from the wire harness.
- Turn the main switch to "ON".
- Turn the "TURN" switch to the "R" or "L".
- Connect the pocket tester (DC20V) to the flasher relay coupler.

**Positive tester probe → Brown ② Terminal**  
**Negative tester probe → Frame ground.**

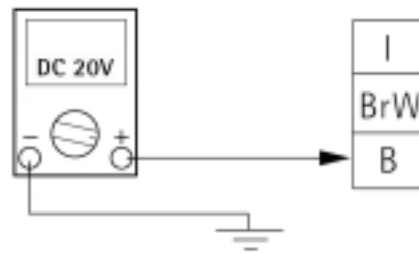

- Check the flasher voltage.



**Flasher voltage**  
**12.0 V**

- Is the flasher relay OK?

↓ YES
↓ NO

Replace the flasher relay.

EAS00795

5. Wiring

- Check the entire signal system's wiring. Refer to "CIRCUIT DIAGRAM".
- Is the signaling system's wiring properly connected and without defects?

↓ YES
↓ NO

Check the condition of each of the signaling system's circuits. Refer to "CHECKING THE SIGNALING SYSTEM".

Properly connect or repair the signaling system's wiring.

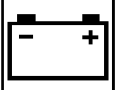

**BRAKE LIGHT DOES NOT COME ON**

1. Bulb

- Remove the bulb.
- Connect the pocket tester ( $\Omega$  1) to the bulb terminals.

Positive tester probe  $\rightarrow$  terminal ①  
 Negative tester probe  $\rightarrow$  terminal ②

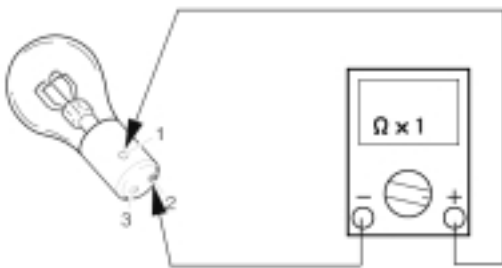

- Check the bulb for continuity.
- Is the bulb OK?

↓ YES

↓ NO

Replace the bulb

2. Bulb socket

- Disconnect the bulb socket coupler ① from the wire harness.
- Connect the pocket tester ( $\Omega$  1) to the bulb socket leads.

Positive tester probe  $\rightarrow$  Yellow ②  
 Terminal  
 Negative tester probe  $\rightarrow$  Black ③  
 Terminal

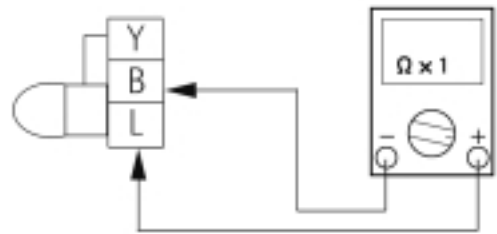

- Check the bulb socket for continuity.
- Is the bulb socket OK?

↓ YES

↓ NO

Replace the bulb socket.

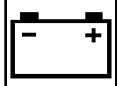

**3. Front brake switch**

- Disconnect the front brake switch coupler ① from the wire harness.
- Connect the pocket tester ( $\Omega$  1) to the brake switch coupler.

**Positive tester probe → Brown Terminal**  
**Negative tester probe → Green/Yellow Terminal**

- Check the brake switch for continuity.

Switch position	Good condition	Bad condition		
		X	X	○
Front brake applied	○	X	X	○
Front brake not applied	X	○	X	○

○:Continuity      X: No continuity

- Is the front brake switch OK?

↓ YES

↓ NO

Replace the front brake switch.

**4. Rear brake switch**

- Disconnect the front brake switch coupler ① from the wire harness.
- Connect the pocket tester ( $\Omega$  1) to the brake switch coupler.

**Positive tester probe → Brown ② Terminal**  
**Negative tester probe → Green/Yellow ③ Terminal**

- Check the brake switch for continuity.

Switch position	Good condition	Bad condition		
		X	X	○
Rear brake applied	○	X	X	○
Rear brake not applied	X	○	X	○

○:Continuity      X: No continuity

- Is the rear brake switch OK?

↓ YES

↓ NO

Replace the rear brake switch.

EAS00795

**5. Wiring**

- Check the entire signal system's wiring. Refer to "CIRCUIT DIAGRAM".
- Is the signaling system's wiring properly connected and without defects?

↓ YES

↓ NO

Check the condition of each of the signaling system's circuits. Refer to "CHECKING THE SIGNALING SYSTEM".

Properly connect or repair the signaling system's wiring.

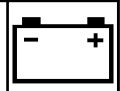

**“NEUTRAL” INDICATOR LIGHT DOES NOT COME ON**

1. Bulb

- Remove the bulb. Refer to the “METER ASSEMBLY” section.
- Connect the pocket tester ( $\Omega$  1) to the bulb terminals.

**Positive tester probe → terminal ①**  
**Negative tester probe → terminal ②**

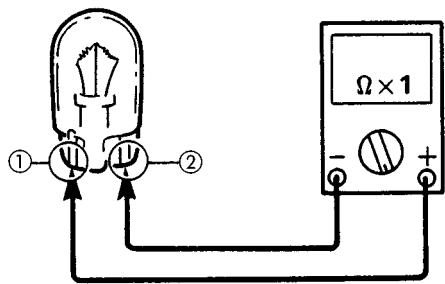

- Check the bulb for continuity.
- Is the bulb OK?

↓ YES

↓ NO

Replace the bulb.

2. Bulb socket

- Disconnect the bulb socket coupler from the wire harness.
- Connect the pocket tester ( $\Omega$  1) to the bulb socket leads.

**Positive tester probe → Brown ② Terminal**  
**Negative tester probe → Sky Blue ③ Terminal**

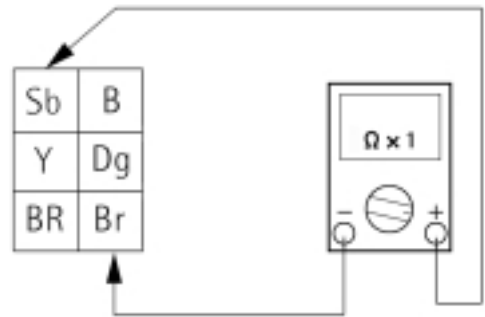

- Check the bulb socket for continuity.
- Is the bulb socket OK?

↓ YES

↓ NO

Replace the bulb socket.

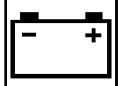

EAS00795

### 3. Neutral switch

- Disconnect the CDI magneto coupler from the wire harness.
- Connect the pocket tester ( $\Omega$  1) to the neutral switch coupler.

**Positive tester probe → Sky Blue Terminal**

**Negative tester probe → Frame ground**

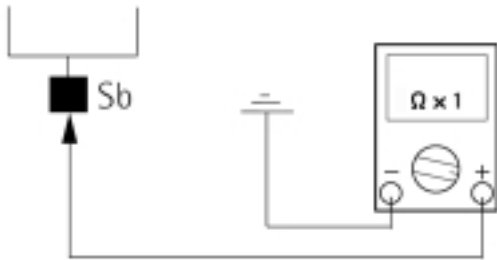

- Shift the transmission in neutral and gear.
- Check the neutral switch for continuity.

Switch position	Good condition	Bad condition		
		Continuity	No continuity	Continuity
Neutral	○	X	X	○
Gear	X	○	X	○

○:Continuity      X: No continuity

- Is the neutral switch OK?

↓ YES

↓ NO

Replace the neutral switch.

### 4. Wiring

- Check the entire signal system's wiring. Refer to "CIRCUIT DIAGRAM".
- Is the signaling system's wiring properly connected and without defects?

↓ YES

↓ NO

Check the condition of each of the signaling system's circuits. Refer to "CHECKING THE SIGNALING SYSTEM".

Properly connect or repair the signaling system's wiring.

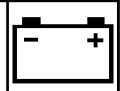

**“OIL” INDICATOR LIGHT DOES NOT COME ON**

1. Bulb

- Remove the bulb. Refer to the “METER ASSEMBLY” section.
- Connect the pocket tester ( $\Omega$  1) to the bulb terminals.

**Positive tester probe** → terminal ①  
**Negative tester probe** → terminal ②

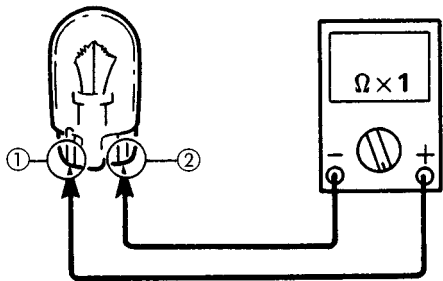

- Check the bulb for continuity.
- Is the bulb OK?

↓ YES

↓ NO

Replace the bulb.

2. Bulb socket

- Disconnect the bulb socket coupler ① from the wire harness.
- Connect the pocket tester ( $\Omega$  1) to the coupler.

**Positive tester probe** → **Brown** ②  
**Terminal**  
**Negative tester probe** → **Black/Red** ③  
**Terminal**

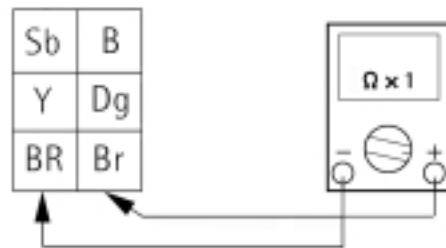

- Check the bulb socket for continuity.
- Is the bulb socket OK?

↓ YES

↓ NO

Replace the bulb socket.

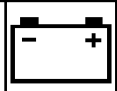

3. Oil level switch (Diode)

- Disconnect the oil level switch ① from the wire harness.
- Connect the pocket tester ( $\Omega$  1) to the neutral switch coupler.

**Positive tester probe → Black/Red ① Terminal**  
**Negative tester probe → Sky Blue ② Terminal**

- Check the oil level switch for continuity.

- Is the oil level switch OK?

↓ YES

↓ NO

Replace the oil level switch.

4. Oil level switch

- Connect the pocket tester ( $\Omega$  1) to the oil level switch.

**Positive tester probe → Black/Red ① Terminal**  
**Negative tester probe → Black ② Terminal**

- Hold the oil level switch in an upright and upside down position.
- Check the oil level switch for continuity.

Switch position	Good condition	Bad condition	
Upright	○	X	X
Upside	X	○	X

○: Continuity      X: No continuity

- Is the oil level switch OK?

↓ YES

↓ NO

Replace the oil level switch.

EAS00795

5. Wiring

- Check the entire signal system's wiring. Refer to "CIRCUIT DIAGRAM".
- Is the signaling system's wiring properly connected and without defects?

↓ YES

↓ NO

Check the condition of each of the signaling system's circuits. Refer to "CHECKING THE SIGNALING SYSTEM".

Properly connect or repair the signaling system's wiring.



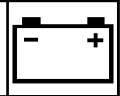

**HORN DOES NOT SOUND, WHEN PUSHING "HORN" SWITCH**

1. "HORN" switch

- Disconnect the "HORN" switch (Left hand-lebar switch) couplers from the wire harness.
- Connect the pocket tester ( $\Omega$  1) to the "HORN" switch.

Positive tester probe → Pink Terminal  
 Negative tester probe → Black Terminal

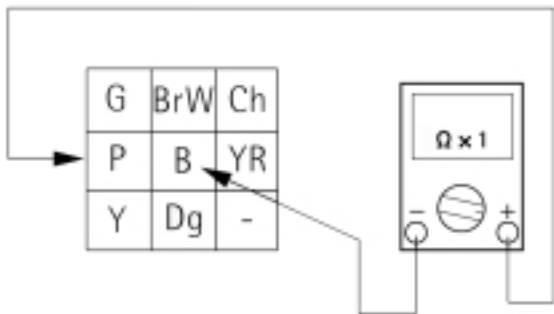

- Check the "HORN" switch for continuity.

Switch position	Good condition	Bad condition		
		○	X	○
"HORN" switch is pushed	○	X	X	○
"HORN" switch is not pushed	X	○	X	○

○: Continuity      X: No continuity

- Is the oil level switch OK?

↓ YES

↓ NO

Replace the "HORN" switch.

2. Voltage

- Connect the pocket tester (DC20V) to the horn terminal.

Positive tester probe → Brown ② Terminal  
 Negative tester probe → Frame ground.

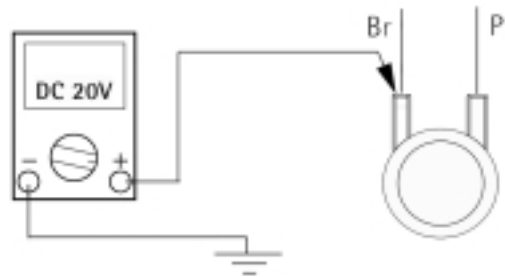

- Turn the main switch to "ON".
- Check the horn voltage.



Horn voltage  
 12.0 V

EAS00795

3. Wiring

- Check the entire signal system's wiring. Refer to "CIRCUIT DIAGRAM".
- Is the signaling system's wiring properly connected and without defects?

↓ YES

↓ NO

Check the condition of each of the signaling system's circuits. Refer to "CHECKING THE SIGNALING SYSTEM".

Properly connect or repair the signaling system's wiring.

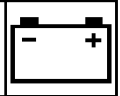

4. Horn

- Disconnect the “pink” lead at the horn terminal.
- Connect a jumper lead ① to the horn terminal and ground the jumper lead.

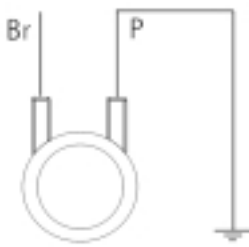

- Does the horn sounds OK?

↓ YES

↓ NO

Replace the horn.

5. Voltage

- Connect the pocket tester (DC20V) to the horn at the pink terminal.

**Positive tester probe → Pink ② Terminal**  
**Negative tester probe → Frame ground.**

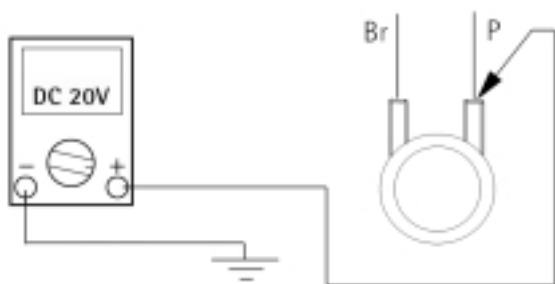

- Check the “pink” terminal voltage.



**“Pink” terminal voltage**  
**12.0 V**

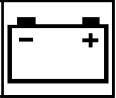

EAS00807

**COOLING SYSTEM**  
**CIRCUIT DIAGRAM**

- ③ Battery
- ⑦ Main switch
- ④ Main fuse
- ⑬ Thermo switch

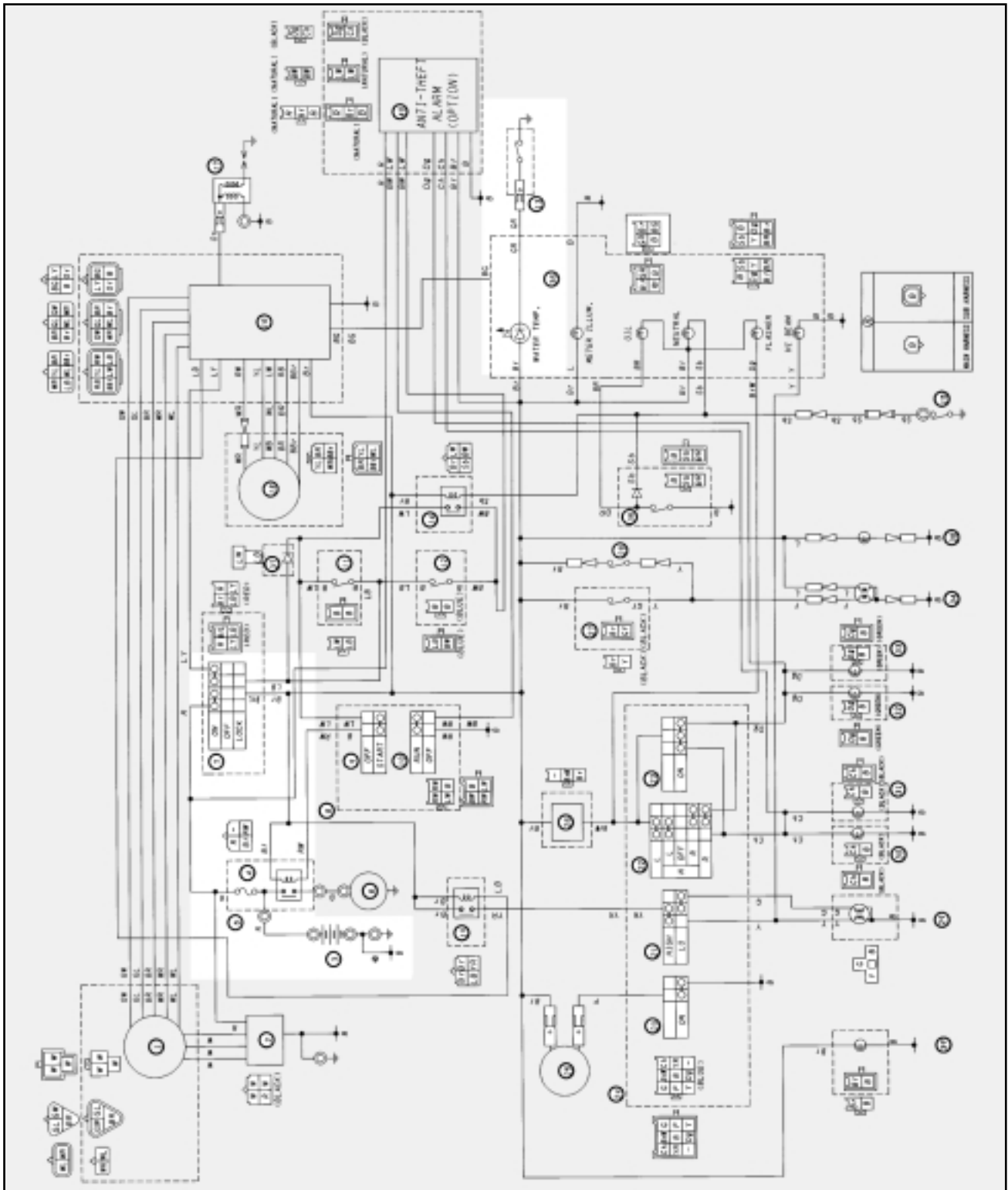

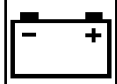

EAS00808

### TROUBLESHOOTING

- **The radiator fan motor fails to turn.**
- **The water temperature gauge needle fails to move when the engine is warm.**

Check:

1. main fuse
2. battery
3. main switch
4. thermo switch
5. wiring connections  
(the entire cooling system)

**NOTE:** \_\_\_\_\_

- Before troubleshooting, remove the following part(s):
  1. side covers (left and right)
  2. seat
  3. fuel tank
  4. headlight cover
  5. headlight unit
- Troubleshoot with the following special tool(s).



**Pocket tester**  
**90890-03112**

#### 1. Fuse

- Remove the fuse.
- Connect the pocket tester ( $\Omega$  1) to the fuse.
- Check the fuse for continuity.
- Is the fuse OK?



YES



NO

Replace the fuse.

#### 2. Battery

- Check the battery condition.  
Refer to the "BATTERY INSPECTION" section in chapter 3.

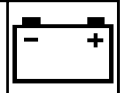

### 3. Main switch

- Disconnect the main switch coupler from the wire harness.
- Connect the pocket tester ( $\Omega$  1) to the main switch.

**Positive tester probe** → Red Lead  
**Negative tester probe** → Brown-Blue Terminal

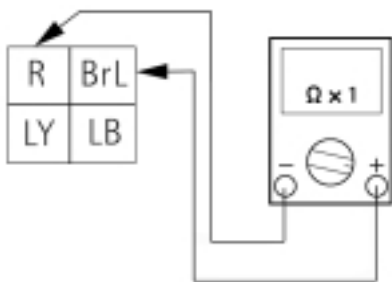

- Turn the main switch to “ON”, “OFF” and “PARK”.
- Check the main switch for continuity.

Switch position	Good condition		Bad condition		
	○	X	○	X	○
ON	○	X	○	X	○
OFF	X	○	○	X	○
PARK	X	○	○	X	○

○: Continuity      X: No continuity

↓ YES

↓ NO

Replace the main switch.

### 4. Thermo unit

- Remove the thermo unit from the cylinder head.
- Connect the pocket tester ( $\Omega$  1) to the thermo unit ①
- Immerse the thermo unit in the water ②
- Measure the resistances. Note temperatures while heating the water with the temperature gauge ③

**Positive tester probe** → Terminal ④  
**Negative tester probe** → Body ground ⑤

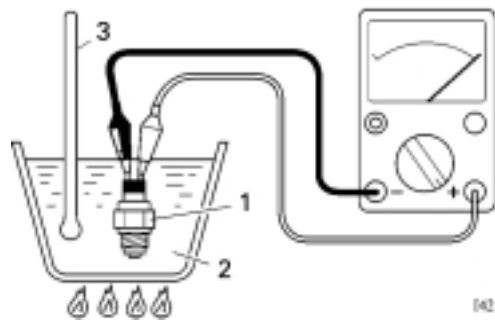

Water temperature	50°C (122°F)	80°C (176°F)	100°C (212°F)
Resistance	153.9 $\Omega$	47.5~56.8 $\Omega$	26.2~29.3 $\Omega$

- Is the thermo unit OK?

↓ YES

↓ NO

Replace the thermo unit.

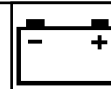

EAS00795

## 5. Wiring

- Check the entire signal system's wiring. Refer to "CIRCUIT DIAGRAM".
- Is the signaling system's wiring properly connected and without defects?

↓ YES

Check the condition of each of the signaling system's circuits. Refer to "CHECKING THE SIGNALING SYSTEM".

↓ NO

Properly connect or repair the signaling system's wiring.

**YAMAHA POWER VALVE SYSTEM**  
CIRCUIT DIAGRAM

- ⑬ CDI Unit
- ⑦ Main switch
- ④ Main fuse
- ③ Battery
- ⑱ Servomotor

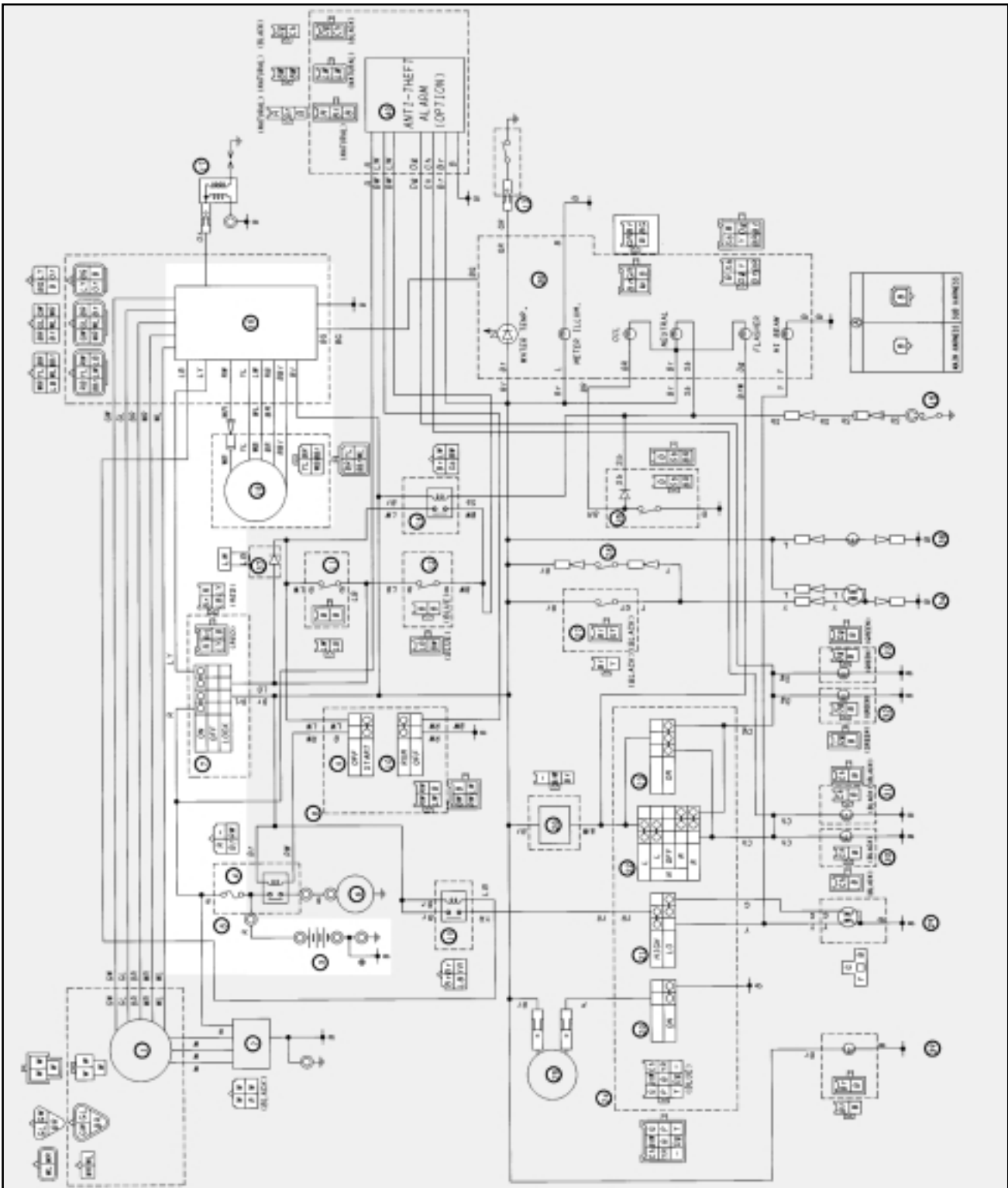

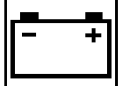

## TROUBLESHOOTING

**Servomotor does not move**

Check:

1. fuse
2. battery
3. main switch
4. servomotor operation
5. wiring connections (Yamaha Power Valve System)
6. servomotor and tachometer operation

**NOTE:**

- Before troubleshooting, remove the following part(s):
  1. side covers (left and right)
  2. seat
  3. fuel tank
  4. headlight cover
  5. headlight unit
- Troubleshoot with the following special tool(s).

**Pocket tester**  
 90890-03112

## 1. Fuse

- Remove the fuse.
- Connect the pocket tester ( $\Omega$  1) to the fuse.
- Check the fuse for continuity.
- Is the fuse OK?



YES



NO

Replace the fuse.

## 2. Battery

- Check the battery condition.  
Refer to the "BATTERY INSPECTION" section in chapter 3.



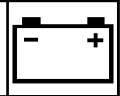

3. Main switch

- Disconnect the main switch coupler ① from the wire harness.
- Connect the pocket tester ( $\Omega$  1) to the main switch.

Positive tester probe → Red ② Lead  
 Negative tester probe → Brown-Blue ③ Terminal

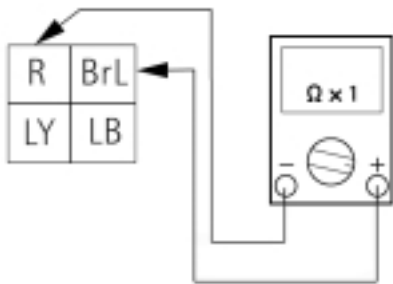

- Turn the main switch to “ON”, “OFF” and “PARK”.
- Check the main switch for continuity.

Switch position	Good condition	Bad condition		
ON	○	X	X	○
OFF	X	○	X	○
PARK	X	○	X	○

○: Continuity      X: No continuity

↓ YES

↓ NO

Replace the main switch.

4. Servomotor operation

- Disconnect servomotor coupler ① from the wire harness.
- Connect the battery leads to the servomotor.

Positive tester probe → Brown ② Terminal  
 Negative tester probe → Black ③ Terminal

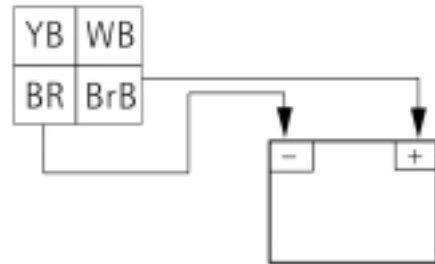

- Check the servomotor for operation.
- Is the servomotor OK?

↓ YES

↓ NO

Replace the servomotor.

EAS00795

5. Wiring

- Check the entire signal system’s wiring. Refer to “CIRCUIT DIAGRAM”.
- Is the signaling system’s wiring properly connected and without defects?

↓ YES

↓ NO

Check the condition of each of the signaling system’s circuits. Refer to “CHECKING THE SIGNALING SYSTEM”.

Properly connect or repair the signaling system’s wiring.

6. Servomotor and tachometer operation	
<ul style="list-style-type: none"><li>• Start the engine and increase revolution to about 7000rev/min.</li><li>• Check servomotor and tachometer for operation.</li></ul>	
	<b>Pocket tester</b> 90890-03112
<ul style="list-style-type: none"><li>• Is the servomotor OK?</li></ul>	

↓ YES

↓ NO

Replace the servomotor.

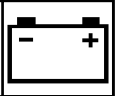

METER ASSEMBLY

- ① Speedometer
- ② Bulb
- ③ Bulb socket
- ④ Speedometer cable
- ⑤ Meter cushion
- ⑥ Meter bracket
- ⑦ Stopper clip
- ⑧ Washer
- ⑨ Damper collar

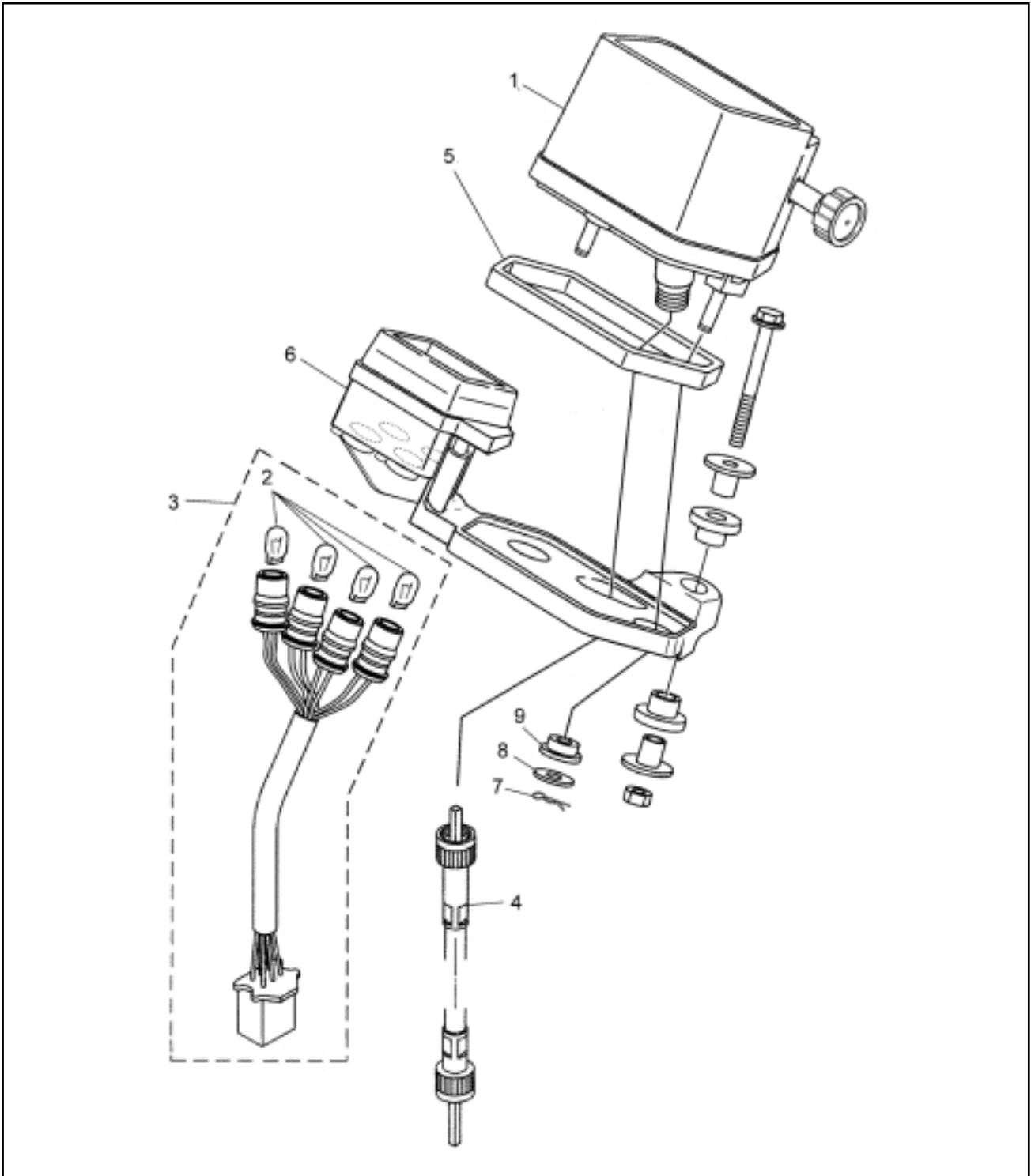

## METER ASSEMBLY

ELEC

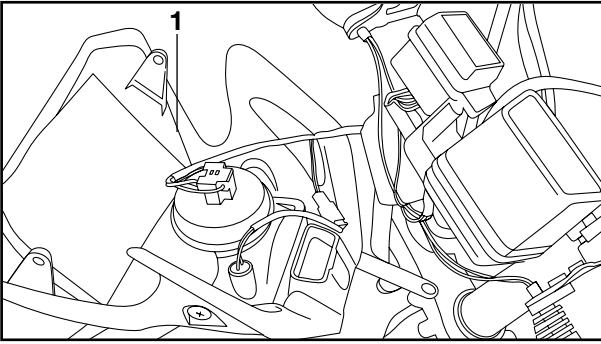
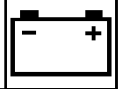

### REMOVAL

1. Remove:
  - Headlight cover ①

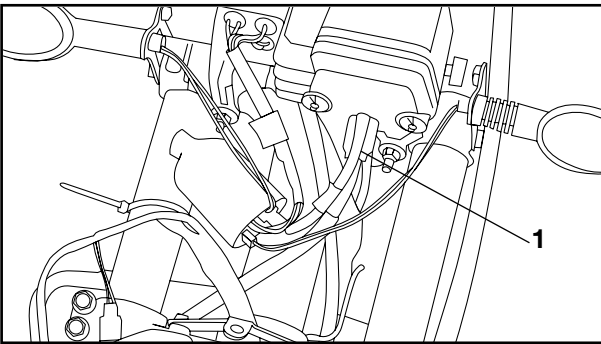

2. Disconnect:
  - Headlight leads
  - Auxiliary light leads

3. Remove:
  - Band
4. Disconnect:
  - Speedometer cable ①

5. Disconnect:
  - Meter leads ①

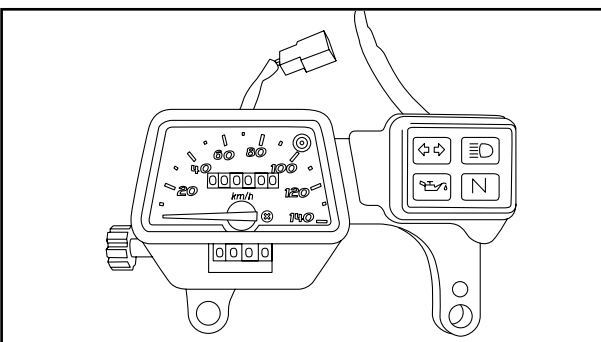

6. Remove:
  - Meter assembly

## METER ASSEMBLY

ELEC

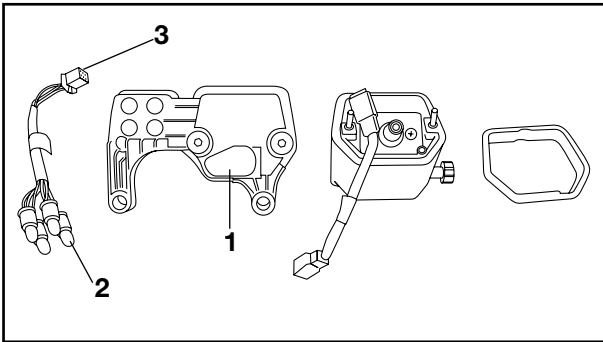
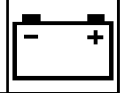

7. Remove:

- Meter cushion ①
- Meter lights ②
- Leads ③

### CAUTION

Do not remove the indicator bulbs sockets by pulling the leads

## INSTALLATION

Reverse the "REMOVAL" procedure. Note the following points:

1. Install the meter lights, indicator lights and leads as shown.

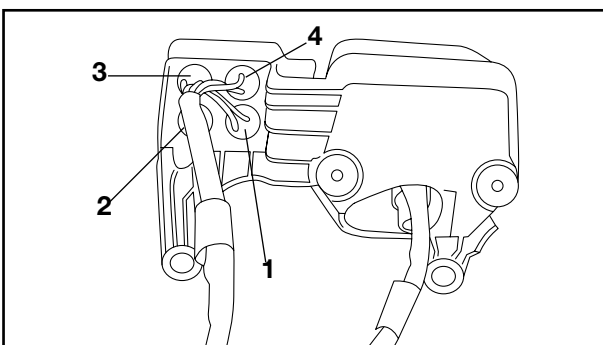

- ① "OIL" indicator light
- ② "NEUTRAL" indicator light
- ③ "HIGH BEAM" indicator light
- ④ "TURN" indicator light

2. Install:

- Meter assembly ①

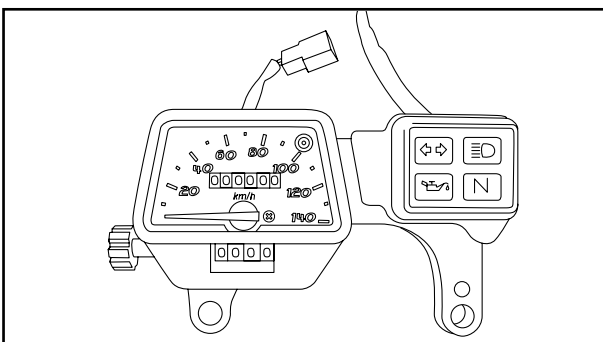

**Bolt (Meter Assembly)**  
7 Nm (0.7 m•kg, 5.1 ft•lb)

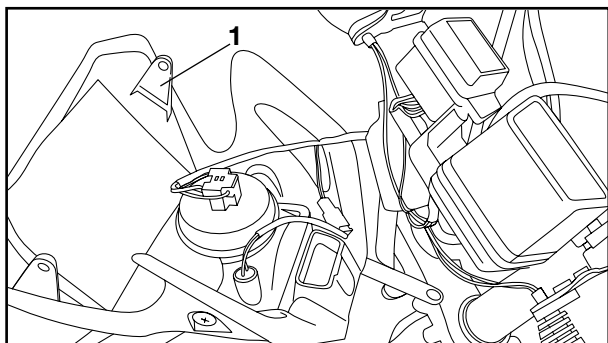
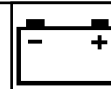
**NOTE:**

Install the headlight lens unit onto the headlight stay by fitting the guide rubber ② properly in the guide hole ③ of the headlight unit.

**3. Install:**

- Headlight cover ①

**4. Adjust:**

- Headlight beam

Refer to the “HEADLIGHT BEAM ADJUSTMENT” section.



**TRBL**

**SHTG**

?

9



## CHAPTER 9 TROUBLESHOOTING

<b>STARTING FAILURE / HARD STARTING</b> .....	9-1
FUEL SYSTEM .....	9-1
ELECTRICAL SYSTEM .....	9-2
<b>POOR IDLE SPEED PERFORMANCE</b> .....	9-3
POOR IDLE SPEED PERFORMANCE .....	9-3
<b>POOR MEDIUM AND HIGH SPEED PERFORMANCE</b> .....	9-3
FUEL SYSTEM .....	9-3
ELECTRICAL SYSTEM .....	9-3
COMPRESSION SYSTEM .....	9-4
Y.P.V.S. ....	9-4
<b>FAULTY GEAR SHIFTING</b> .....	9-5
HARD SHIFTING .....	9-5
CHANGE PEDAL DOES NOT MOVE .....	9-5
JUMP OUT GEAR .....	9-5
<b>CLUTCH SLIPPING/Dragging</b> .....	9-5
CLUTCH SLIPPING .....	9-5
CLUTCH DRAGGING .....	9-6
<b>FAULTY BRAKE</b> .....	9-6
POOR BRAKING EFFECT .....	9-6
<b>FRONT FORK OIL LEAKAGE AND FRONT FORK MALFUNCTION</b> .....	9-6
OIL LEAKAGE .....	9-6
MALFUNCTION .....	9-6
<b>INSTABLE HANDLING</b> .....	9-7
INSTABLE HANDLING .....	9-7
<b>FAULTY SIGNAL AND LIGHTING SYSTEM</b> .....	9-8
HEADLIGHT DARK .....	9-8
BULB BURNT OUT .....	9-8
FLASHER DOES NOT LIGHT .....	9-8
FLASHER KEEPS ON .....	9-8
FLASHER WINKS SLOWER .....	9-8
FLASHER WINKS QUICKER .....	9-8
HORN IS INOPERATIVE .....	9-8
<b>FAULTY Y.P.V.S.</b> .....	9-9
FAULTY Y.P.V.S. ....	9-9
<b>OVERHEATING OR OVERCOOLING</b> .....	9-9
OVERHEATING .....	9-9
OVERCOOLING .....	9-9
<b>DT125 WIRING DIAGRAM</b> .....	9-10



# TROUBLESHOOTING



## ELECTRICAL SYSTEM

## PROBABLE CAUSE

- Spark plug
  - Improper plug gap
  - Worn electrodes
  - Wire between terminals broken
  - Improper heat range
  - Faulty spark plug cap
- Ignition coil
  - Broken or shorted primary/secondary
  - Faulty spark plug lead
  - Broken body
- C.D.I. Unit system
  - Faulty C.D.I. unit
  - Faulty source coil
  - Faulty pick-up coil
  - Broken woodruff key
- Switches and wiring
  - Faulty main switch
  - Faulty engine stop switch
  - Broken or shorted wiring
  - Faulty neutral switch
  - Faulty sidestand switch
  - Faulty ignition control unit

## COMPRESSION SYSTEM

## PROBABLE CAUSE

- Cylinder and cylinder head
  - Loose spark plug
  - Loose cylinder head or cylinder
  - Broken cylinder head gasket
  - Broken cylinder gasket
  - Worn, damaged or seized cylinder
- Piston and piston rings
  - Improperly installed piston ring
  - Worn, fatigued or broken piston ring
  - Seized piston ring
  - Seized or damaged piston
- Crankcase and crankshaft
  - Improperly seated crankcase
  - Improperly sealed crankcase (Damaged oil seal)
  - Seized crankshaft
- Reed valve
  - Deformed reed valve stopper
  - Improperly seated reed valve
  - Loose intake manifold
  - Broken gasket
  - Broken reed valve



## POOR IDLE SPEED PERFORMANCE

### POOR IDLE SPEED PERFORMANCE

- Carburetor

### PROBABLE CAUSE

- Improperly returned starter plunger
- Clogged or loose pilot jet
- Clogged pilot air passage
- Improperly adjusted idle speed (throttle stop screw)
- Improper throttle cable play
- Faulty pick up coil

## POOR MEDIUM AND HIGH SPEED PERFORMANCE

### FUEL SYSTEM

- Fuel tank

### PROBABLE CAUSE

- Clogged fuel filter
- Deteriorated fuel or fuel containing water or foreign material
- Clogged fuel breather hose

- Fuel cock

- Clogged fuel hose

- Carburetor

- Deteriorated fuel or fuel containing water or foreign material
- Sucked-in air
- Deformed float
- Groove worn needle valve
- Improperly sealed valve seat
- Improperly set clip position of jet needle
- Improperly adjusted fuel level
- Clogged or loose main jet
- Clogged or loose needle jet

- Air cleaner

- Clogged air filter

### ELECTRICAL SYSTEM

- Spark plug

### PROBABLE CAUSE

- Improper plug gap
- Worn electrodes
- Wire between terminals broken
- Improper heat range
- Faulty spark plug cap

- CDI unit system

- Faulty CDI unit
- Faulty source coil
- Faulty pickup coil

# TROUBLESHOOTING



## COMPRESSION SYSTEM

## PROBABLE CAUSE

- Cylinder and cylinder head
  - Loose spark plug
  - Broken cylinder head gasket
  - Broken cylinder gasket
  - Loose cylinder head or cylinder
  - Worn, damaged or seized cylinder
  
- Piston and piston ring
  - Improperly installed piston ring
  - Worn, fatigued or broken piston ring
  - Seized piston ring
  - Seized or damaged piston
  
- Crankcase and crankshaft
  - Improperly seated crankcase
  - Improperly sealed crankcase (Damaged oil seal)
  - Seized crankshaft
  
- Reed valve
  - Deformed reed valve stopper
  - Improperly adjusted reed valve stopper height
  - Improperly seated reed valve
  - Loose intake manifold
  - Broken gasket
  - Broken reed valve

## Y.P.V.S.

## PROBABLE CAUSE

- Power valve
  - Seized or damaged power valve
  - Carbon build-up
  
- Control cable
  - Improperly adjustable cable
  - Seized or discontinuous cable
  
- Electrical parts
  - Faulty battery (Improperly charged battery)
  - Faulty main switch
  - Faulty servomotor
  - Faulty GDI unit
  - Faulty Y.P.V.S. control unit
  - Broken or shorted wiring

## FAULTY GEAR SHIFTING

### HARD SHIFTING

### PROBABLE CAUSE

- |  |   |   |
|--|---|---|
| <ul style="list-style-type: none"> <li>• Clutch</li> </ul>           | <div style="border-bottom: 1px solid black; height: 10px; width: 100%;"></div> <div style="border-bottom: 1px solid black; height: 10px; width: 100%;"></div> <div style="border-bottom: 1px solid black; height: 10px; width: 100%;"></div> <div style="border-bottom: 1px solid black; height: 10px; width: 100%;"></div> | <ul style="list-style-type: none"> <li>• Improperly adjusted clutch cable</li> <li>• Improperly adjusted push lever position</li> <li>• Improper engagement of push lever and push rod</li> <li>• Warped clutch plate</li> <li>• Swollen friction plate</li> <li>• Broken clutch plate</li> </ul> |
| <ul style="list-style-type: none"> <li>• Transmission oil</li> </ul> | <div style="border-bottom: 1px solid black; height: 10px; width: 100%;"></div> <div style="border-bottom: 1px solid black; height: 10px; width: 100%;"></div>   | <ul style="list-style-type: none"> <li>• High oil level</li> <li>• Improper quality (High viscosity)</li> <li>• Deterioration</li> </ul>  |

### CHANGE PEDAL DOES NOT MOVE

### PROBABLE CAUSE

- |  |   |   |
|--|---|---|
| <ul style="list-style-type: none"> <li>• Shift shaft</li> </ul>              | <div style="border-bottom: 1px solid black; height: 10px; width: 100%;"></div>  | <ul style="list-style-type: none"> <li>• Bent shift shaft</li> </ul>  |
| <ul style="list-style-type: none"> <li>• Shift cam and shift fork</li> </ul> | <div style="border-bottom: 1px solid black; height: 10px; width: 100%;"></div> <div style="border-bottom: 1px solid black; height: 10px; width: 100%;"></div> | <ul style="list-style-type: none"> <li>• Groove jammed with impurities</li> <li>• Seized shift fork</li> <li>• Bent shift forks guide bar</li> </ul>    |
| <ul style="list-style-type: none"> <li>• Transmission</li> </ul>             | <div style="border-bottom: 1px solid black; height: 10px; width: 100%;"></div> <div style="border-bottom: 1px solid black; height: 10px; width: 100%;"></div> | <ul style="list-style-type: none"> <li>• Seized transmission gear</li> <li>• Jammed impurities</li> <li>• Incorrectly assembled transmission</li> </ul> |

### JUMP OUT GEAR

### PROBABLE CAUSE

- |  |  |   |
|--|--|---|
| <ul style="list-style-type: none"> <li>• Shift shaft</li> </ul>  | <div style="border-bottom: 1px solid black; height: 10px; width: 100%;"></div> | <ul style="list-style-type: none"> <li>• Improperly adjusted shift lever position</li> <li>• Improperly returned stopper lever</li> </ul> |
| <ul style="list-style-type: none"> <li>• Shift fork</li> </ul>   | <div style="border-bottom: 1px solid black; height: 10px; width: 100%;"></div> | <ul style="list-style-type: none"> <li>• Worn shift fork</li> </ul>   |
| <ul style="list-style-type: none"> <li>• Shift cam</li> </ul>    | <div style="border-bottom: 1px solid black; height: 10px; width: 100%;"></div> | <ul style="list-style-type: none"> <li>• Improper thrust play</li> <li>• Worn shift cam groove</li> </ul>                                 |
| <ul style="list-style-type: none"> <li>• Transmission</li> </ul> | <div style="border-bottom: 1px solid black; height: 10px; width: 100%;"></div> | <ul style="list-style-type: none"> <li>• Worn gear dog</li> </ul>   |

## CLUTCH SLIPPING/Dragging

### CLUTCH SLIPPING

### PROBABLE CAUSE

- |  |   |   |
|--|---|---|
| <ul style="list-style-type: none"> <li>• Clutch</li> </ul>       | <div style="border-bottom: 1px solid black; height: 10px; width: 100%;"></div> <div style="border-bottom: 1px solid black; height: 10px; width: 100%;"></div> <div style="border-bottom: 1px solid black; height: 10px; width: 100%;"></div> <div style="border-bottom: 1px solid black; height: 10px; width: 100%;"></div> | <ul style="list-style-type: none"> <li>• Improperly adjusted clutch cable</li> <li>• Loose clutch spring</li> <li>• Fatigued clutch spring</li> <li>• Worn friction plate</li> <li>• Worn clutch plate</li> </ul> |
| <ul style="list-style-type: none"> <li>• Transmission</li> </ul> | <div style="border-bottom: 1px solid black; height: 10px; width: 100%;"></div> <div style="border-bottom: 1px solid black; height: 10px; width: 100%;"></div>   | <ul style="list-style-type: none"> <li>• Low oil level</li> <li>• Improper quality (Low viscosity)</li> <li>• Deterioration</li> </ul>  |

# TROUBLESHOOTING



## CLUTCH DRAGGING

- Clutch

## PROBABLE CAUSE

- Improperly adjusted clutch cable
- Improperly adjusted push lever position
- Improper engagement of push lever and push rod
- Warped clutch plate
- Swollen friction plate
- Broken clutch boss

- Transmission oil

- High oil level
- Improper quality (High viscosity)
- Deterioration

## **FAULTY BRAKE**

### POOR BRAKING EFFECT

- Disc brake

### PROBABLE CAUSE

- Worn brake pad
- Worn brake disc
- Air in brake fluid
- Leaking brake fluid
- Faulty cylinder kit cup
- Faulty caliper kit seal
- Loose union bolt
- Broken brake hose
- Oily or grasy brake disc
- Oily or greasy brake pad
- Improper brake fluid level

## **FRONT FORK OIL LEAKAGE AND FRONT FORK MALFUNCTION**

### OIL LEAKAGE

### PROBABLE CAUSE

- Bent, damaged or rusty inner tube
- Damaged or cracked outer tube
- Damaged oil seal lip
- Improperly installed oil seal
- Improper oil level (too much)
- Loose damper rod holding bolt
- Broken

### MALFUNCTION

- Bent, deformed or damaged inner tube
- Bent or deformed outer tube
- Damaged fork spring
- Worn or damaged slide metal
- Bent or damaged damper rod
- Improper oil viscosity
- Improper oil level

**INSTABLE HANDLING**  
INSTABLE HANDLING

PROBABLE CAUSE

- |   |   |
|---|---|
| <ul style="list-style-type: none"> <li>• Handlebars</li> </ul>          | <ul style="list-style-type: none"> <li>• Improperly installed or bent</li> </ul>  |
| <ul style="list-style-type: none"> <li>• Steering</li> </ul>            | <ul style="list-style-type: none"> <li>• Improperly installed handle crown</li> <li>• Bent steering shaft</li> <li>• Improperly installed steering shaft (Improperly tightened ringnut)</li> <li>• Damaged ball bearing (roller bearing or bearing race)</li> </ul> |
| <ul style="list-style-type: none"> <li>• Front forks</li> </ul>         | <ul style="list-style-type: none"> <li>• Uneven oil levels on both sides</li> <li>• Uneven spring tension (Uneven damping adjuster position)</li> <li>• Broken spring</li> <li>• Twisted front forks</li> </ul>   |
| <ul style="list-style-type: none"> <li>• Tires</li> </ul>               | <ul style="list-style-type: none"> <li>• Uneven tire pressure on both sides</li> <li>• Incorrect tire pressure</li> <li>• Unevenly worn tires</li> </ul>  |
| <ul style="list-style-type: none"> <li>• Wheels</li> </ul>              | <ul style="list-style-type: none"> <li>• Incorrect wheel balance</li> <li>• Deformed cast wheel</li> <li>• Loose bearing</li> <li>• Bent or loose wheel axle</li> <li>• Excessive wheel run-out</li> </ul>  |
| <ul style="list-style-type: none"> <li>• Frame</li> </ul>               | <ul style="list-style-type: none"> <li>• Twisted</li> <li>• Damaged head pipe</li> <li>• Improperly installed bearing race</li> </ul>   |
| <ul style="list-style-type: none"> <li>• Swingarm</li> </ul>            | <ul style="list-style-type: none"> <li>• Worn bearing or bush</li> <li>• Bent or damaged</li> </ul>   |
| <ul style="list-style-type: none"> <li>• Rear shock absorber</li> </ul> | <ul style="list-style-type: none"> <li>• Fatigued spring</li> <li>• Improperly adjusted spring preload</li> <li>• Oil leakage</li> </ul>  |
| <ul style="list-style-type: none"> <li>• Drive chain</li> </ul>         | <ul style="list-style-type: none"> <li>• Improperly adjusted chain slack</li> </ul>   |





## FAULTY SIGNAL AND LIGHTING SYSTEM

### HEADLIGHT DARK

#### PROBABLE CAUSE

- Improper bulb
- Too many electric accessories
- Hard charging (Broken charging coil and/or faulty rectifier/regulator)
- Incorrect connection
- Improperly grounded
- Poor contacts (main or "LIGHTS" switch)
- Bulb life expired

### BULB BURNT OUT

#### PROBABLE CAUSE

- Improper bulb
- Faulty battery
- Faulty rectifier/regulator
- Improperly grounded
- Faulty main and/or light switch
- Bulb life expired

### FLASHER DOES NOT LIGHT

#### PROBABLE CAUSE

- Improperly grounded
- Discharged battery
- Faulty "TURN" switch
- Faulty flasher relay
- Broken wireharness
- Loosely connected coupler
- Bulb burnt out

### FLASHER KEEPS ON

#### PROBABLE CAUSE

- Faulty flasher relay
- Insufficient battery capacity (nearly discharged)
- Bulb burnt out

### FLASHER WINKS SLOWER

#### PROBABLE CAUSE

- Faulty flasher relay
- Insufficient battery capacity (nearly discharged)
- Improper bulb
- Faulty main and/or "TURN" switch

### FLASHER WINKS QUICKER

#### PROBABLE CAUSE

- Improper bulb
- Faulty flasher relay

### HORN IS INOPERATIVE

#### PROBABLE CAUSE

- Faulty battery
- Faulty main and/or horn switch
- Improperly adjusted horn
- Faulty horn
- Broken wireharness

# TROUBLESHOOTING



## FAULTY Y.P.V.S.

- | <u>FAULTY Y.P.V.S.</u>   | <u>PROBABLE CAUSE</u>  |
|--|--|
| <ul style="list-style-type: none"> <li>• Power valve</li> </ul>      | <ul style="list-style-type: none"> <li>• Seized or damaged power valve</li> <li>• Carbon build-up</li> </ul>   |
| <ul style="list-style-type: none"> <li>• Control cable</li> </ul>    | <ul style="list-style-type: none"> <li>• Improperly adjusted cable</li> <li>• Seized or discontinuous cable</li> </ul>   |
| <ul style="list-style-type: none"> <li>• Electrical parts</li> </ul> | <ul style="list-style-type: none"> <li>• Insufficient battery capacity (improperly charged battery)</li> <li>• Faulty main switch</li> <li>• Faulty servomotor</li> <li>• Faulty CDI unit</li> <li>• Faulty Y.P.V.S. control unit</li> <li>• Broken or shorted wiring</li> </ul> |

## **OVERHEATING OR OVER-COOLING**

### OVERHEATING

### PROBABLE CAUSE

- |  |   |
|--|---|
| <ul style="list-style-type: none"> <li>• Ignition system</li> </ul>    | <ul style="list-style-type: none"> <li>• Improper spark plug gap</li> <li>• Improper spark plug heat range</li> <li>• Faulty CDI unit</li> </ul>  |
| <ul style="list-style-type: none"> <li>• Fuel system</li> </ul>        | <ul style="list-style-type: none"> <li>• Improper carburetor main jet (improper setting)</li> <li>• Improperly adjusted fuel height</li> <li>• Clogged air cleaner element</li> <li>• Lean mixture (Faulty Autolube pump settings)</li> </ul>   |
| <ul style="list-style-type: none"> <li>• Compression system</li> </ul> | <ul style="list-style-type: none"> <li>• Heavy carbon build-up</li> </ul>   |
| <ul style="list-style-type: none"> <li>• Transmission oil</li> </ul>   | <ul style="list-style-type: none"> <li>• Incorrect oil level</li> <li>• Improper oil viscosity</li> <li>• Inferior oil quality</li> </ul>   |
| <ul style="list-style-type: none"> <li>• Brake</li> </ul>              | <ul style="list-style-type: none"> <li>• Dragging bike</li> </ul>   |
| <ul style="list-style-type: none"> <li>• Cooling system</li> </ul>     | <ul style="list-style-type: none"> <li>• Faulty water temperature gauge</li> <li>• Faulty thermo-unit</li> <li>• Incorrect coolant level</li> <li>• Faulty thermostat valve</li> <li>• Clogged or damaged radiator</li> <li>• Faulty radiator cap</li> <li>• Seized impeller shaft</li> </ul> |

### OVER-COOLING

### PROBABLE CAUSE

- |  |   |
|--|---|
| <ul style="list-style-type: none"> <li>• Cooling system</li> </ul> | <ul style="list-style-type: none"> <li>• Faulty water temperature gauge</li> <li>• Faulty thermo-unit</li> <li>• Faulty thermostat valve</li> </ul> |
|--|---|

# DT125 WIRING DIAGRAM

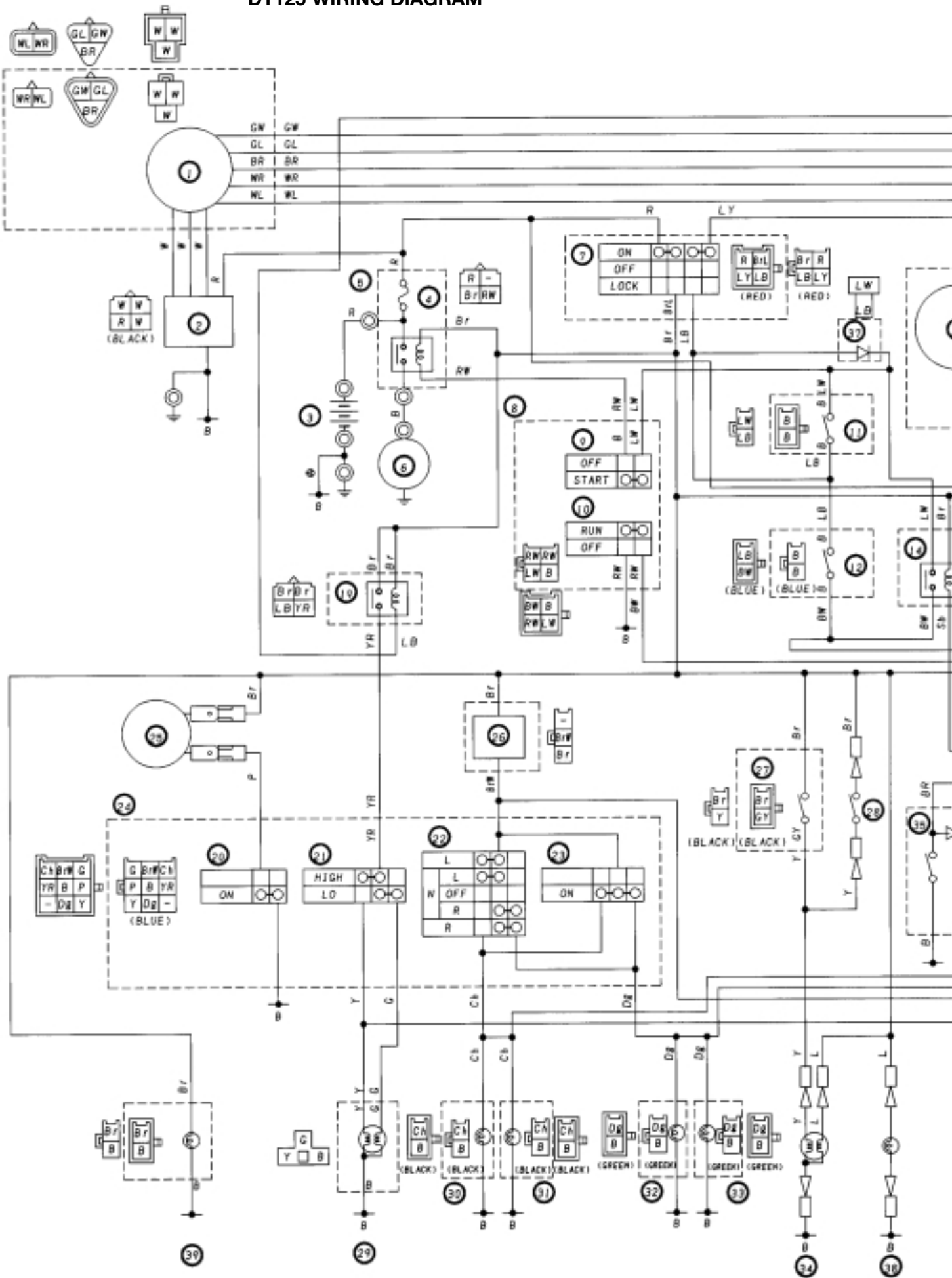

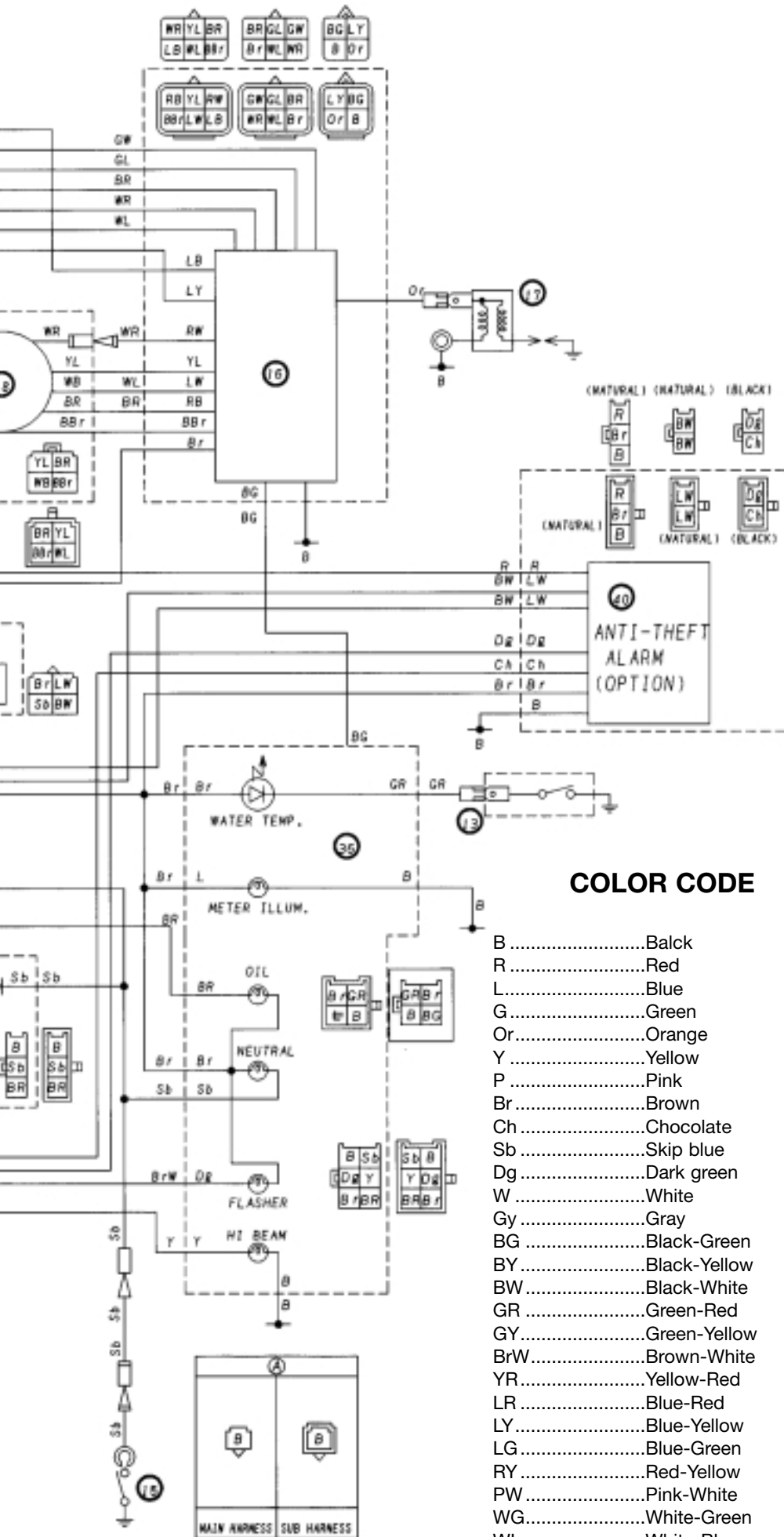

## COMPONENTS

1. CDI. Mag.
2. Rect./Regu.
3. Battery
4. Fuse
5. Starter Relay
6. Starting Motor
7. Main Sw.
8. Handle Sw. R
9. Starter Sw.
10. E/G Stop Sw.
11. Clutch Sw.
12. Side Stand Sw.
13. Thermo Sw.
14. Side Stand Relay
15. Neutral Sw.
16. CDI. Unit
17. Ign. Coil
18. Servo. Motor
19. Lightning Relay
20. Horn Sw.
21. Dimmer Sw.
22. Flasher Sw.
23. Hazard Sw.
24. Handle Sw. L
25. Horn
26. Flasher Relay
27. Fr. Stop Sw.
28. Rr. Stop Sw.
29. Head Light
30. Fr. Lh Flasher
31. Rr. Lh Flasher
32. Fr. Rh Flasher
33. Rr. Rh Flasher
34. Tail/Stop Light
35. Oil Level Gauge
36. Meter
37. Diode 1
38. License Light
39. Position Lamp
40. Anti Theft Unit

## COLOR CODE

B	.....	Black
R	.....	Red
L	.....	Blue
G	.....	Green
Or	.....	Orange
Y	.....	Yellow
P	.....	Pink
Br	.....	Brown
Ch	.....	Chocolate
Sb	.....	Skip blue
Dg	.....	Dark green
W	.....	White
Gy	.....	Gray
BG	.....	Black-Green
BY	.....	Black-Yellow
BW	.....	Black-White
GR	.....	Green-Red
GY	.....	Green-Yellow
BrW	.....	Brown-White
YR	.....	Yellow-Red
LR	.....	Blue-Red
LY	.....	Blue-Yellow
LG	.....	Blue-Green
RY	.....	Red-Yellow
PW	.....	Pink-White
WG	.....	White-Green
WL	.....	White-Blue
WR	.....	White-Red