



**YAMAHA**

[www.legends-yamaha-enduros.com](http://www.legends-yamaha-enduros.com)

**RT180A**

**OWNER'S MANUAL**

**AFFIX DEALER**

[www.legends-yamaha-enduros.com](http://www.legends-yamaha-enduros.com)

**LABEL HERE**

A-000

**RT180A**

**OWNER'S MANUAL**

**©1989 by Yamaha Motor Corporation, U.S.A.**

**1st Edition, October 1989**

**All rights reserved. Any reprinting or  
unauthorized use without the written  
permission of Yamaha Motor Corporation,  
U.S.A. is expressly prohibited.**

**Printed in Brazil**

**P/N LIT-11626-07-30**

# INTRODUCTION

Congratulations on your purchase of the Yamaha RT180A. This model is the result of Yamaha's vast experience in the production of fine sporting, touring, and pacesetting racing machines. It represents the high degree of craftsmanship and reliability that have made Yamaha a leader in these fields.

This manual will give you an understanding of the operation, inspection, and basic maintenance of this machine. If you have any questions about the operation or maintenance of your machine, please consult a Yamaha dealer.

U-001

**NOTE:** \_\_\_\_\_

Some data in this manual may become outdated due to future improvement on this model. If you have any questions about this manual or your machine, please consult a Yamaha dealer.

---

**SERVICE DIVISION  
YAMAHA MOTOR DA AMAZÔNIA LTDA.**

**⚠ WARNING**

---

**PLEASE READ THIS MANUAL CAREFULLY AND COMPLETELY BEFORE OPERATING THIS MACHINE. DO NOT ATTEMPT TO OPERATE THIS MACHINE UNTIL YOU HAVE ATTAINED A SATISFACTORY KNOWLEDGE OF ITS CONTROLS AND OPERATING FEATURES AND UNTIL YOU HAVE BEEN TRAINED IN SAFE AND PROPER RIDING TECHNIQUES. REGULAR INSPECTIONS AND CAREFUL MAINTENANCE, ALONG WITH GOOD RIDING SKILLS, WILL ENSURE THAT YOU SAFELY ENJOY THE CAPABILITIES AND THE RELIABILITY OF THIS MACHINE.**

---



Particularly important information is distinguished in this manual by the following notations:



The Safety Alert Symbol means **ATTENTION! BECOME ALERT! YOUR SAFETY IS INVOLVED!**

**! WARNING**

Failure to follow **WARNING** instructions could result in severe injury or death to the machine operator, a bystander, or a person inspecting or repairing the machine.

**CAUTION:**

A **CAUTION** indicates special precautions that must be taken to avoid damage to the machine.

**NOTE:**

A **NOTE** provides key information to make procedures easier or clear.

U-000

**NOTE:**

---

This manual should be considered a permanent part of this machine and should remain with it even if the machine is subsequently sold.

---

**⚠ WARNING**

---

**THIS MACHINE IS DESIGNED AND MANUFACTURED FOR OFF-ROAD USE ONLY. IT IS ILLEGAL TO OPERATE THIS MACHINE ON ANY PUBLIC STREET, ROAD OR HIGHWAY. SUCH USE IS PROHIBITED BY LAW. THIS MACHINE COMPLIES WITH ALMOST ALL STATE OFF-HIGHWAY NOISE LEVEL AND SPARK ARRESTER LAWS AND REGULATIONS. PLEASE CHECK YOUR LOCAL RIDING LAWS AND REGULATIONS BEFORE OPERATING THIS MACHINE.**

---

## **⚠ SAFETY INFORMATION:**

**TWO-WHEELED MACHINES ARE SINGLE TRACK VEHICLES. THEIR SAFE USE AND OPERATION ARE DEPENDENT UPON THE USE OF PROPER RIDING TECHNIQUES AS WELL AS THE EXPERTISE OF THE OPERATOR.**

**EVERY OPERATOR SHOULD KNOW THE FOLLOWING REQUIREMENTS BEFORE RIDING. HE OR SHE SHOULD:**

- 1. OBTAIN THOROUGH INSTRUCTIONS FROM A COMPETENT SOURCE ON ALL ASPECTS OF MACHINE OPERATION.**
- 2. OBSERVE THE WARNINGS AND MAINTENANCE REQUIREMENTS IN THE OWNER'S MANUAL.**
- 3. OBTAIN PROFESSIONAL TECHNICAL SERVICE AS INDICATED BY THE OWNER'S MANUAL AND/OR WHEN MADE NECESSARY BY MECHANICAL CONDITIONS.**

### **SAFE RIDING**

- 1. Always make pre-operation checks. Careful checks may help prevent an accident.**
- 2. This machine is designed for off-road use only. It is illegal for this machine to be operated on any public street, road or highway. Off-road use on public lands may be illegal. Please check local regulations before riding.**
- 3. This machine is designed to carry the operator only. No passengers.**
- 4. Many accidents involve inexperienced operators.**

- a. Know your skills and limits. Staying within your limits may help you to avoid an accident.
- b. Only lend your machine to experienced operators.
5. Many machine accidents have been caused by machine operator errors. A typical error made by the operator is veering wide on a turn due to **EXCESSIVE SPEED** or undercornering (insufficient lean angle for the speed). Never travel faster than warranted by conditions.
6. Ride cautiously in unfamiliar areas. You may encounter hidden obstacles which could cause an accident.
7. Operator's posture is important for proper control. The operator should keep both hands on the handlebars and both feet on the operator footrests during operation to maintain control of the machine.
8. Never ride under the influence of alcohol or drugs.

[www.legends-yamaha-enduros.com](http://www.legends-yamaha-enduros.com)

## **PROTECTIVE APPAREL**

The majority of fatalities from machine accidents are the result of head injuries. The use of a safety helmet is the single most critical factor in the prevention or reduction of head injuries.

1. Always wear an approved helmet.
2. Wear a face shield or goggles. Wind on your unprotected eyes could contribute to an impairment of vision which could delay seeing a hazard.
3. The use of heavy boots, jacket, trousers, gloves, etc. is effective in preventing or reducing abrasions or lacerations.



4. Never wear loose fitting clothing. It could catch on the control levers, footrests, or wheels and cause injury or accident.
5. Never touch the engine or exhaust system during or after operation. They become very hot and can cause burns. Always wear protective clothing that covers your legs, ankles, and feet.

## **MODIFICATION**

Modifications made to the machine not approved by Yamaha, or the removal of original equipment, may render your machine unsafe for use and may cause severe personal injury. Modifications may also make your machine illegal to use.

## **ACCESSORIES AND LOADING**

Adding accessories or cargo to your machine can adversely affect stability and handling, if the weight distribution of the machine is changed. To avoid the possibility of an accident, extreme caution should be used if adding cargo or accessories to your machine. Use extra care if riding a machine which has added cargo or accessories.

Genuine Yamaha accessories have been specifically designed for use on this machine. Since Yamaha can not test all other accessories which may be available, you must personally be responsible for the proper selection, installation and use of non-Yamaha accessories. You should use extreme caution when selecting and installing any accessories. Keep in mind these guidelines:



1. **Never install accessories or carry cargo that would impair the performance of your machine. Carefully inspect the accessory before using it to make sure it does not in any way reduce ground clearance or cornering clearance limit suspension travel, steering travel or control operation, or obscure lights or reflectors.**
  - a. **Accessories fitted to the handlebar or the front fork area can create instability due to improper weight distribution or aerodynamic changes. If accessories are added to the handlebar or front fork area, they must be as light weight as possible and should be kept to a minimum.**
  - b. **Certain accessories cargo can displace the operator from his or her normal riding position. This improper position limits the freedom of movement of the operator and may limit the ability to control the machine, which could lead to an accident.**

## **GASOLINE AND EXHAUST GAS**

1. **GASOLINE IS HIGHLY FLAMMABLE:**
  - a. **Always turn off the engine when refuelling.**
  - b. **Take care not to spill any gasoline on the engine or exhaust pipe(s)/muffler(s) when refueling.**
  - c. **Never refuel while smoking or in the vicinity of an open flame.**
2. **Never start the engine or let it run for any length of time in a closed area. The exhaust fumes are poisonous and may cause loss of consciousness and death within a short time. Always operate your machine in an area that has adequate ventilation.**

3. Always turn off the engine before leaving the machine unattended and remove the ignition key. When parking the machine, note the following:
  - a. The engine and exhaust pipe(s)/muffler(s) may be hot. Park the machine in a place where pedestrians or children are not likely to touch these hot areas.
  - b. Do not park the machine on a slope or soft ground: the machine may fall over.
  - c. Do not park the machine near a flammable source, e.g. a kerosene heater, water heater, clothes dryer, open flame or other source of ignition.
4. When transporting the machine in another vehicle, be sure it is kept upright and that the fuel cock is turned to "OFF". If it should lean over, gasoline may leak out of the carburetor or fuel tank.
5. If you should swallow any gasoline, inhale a lot of gasoline vapor, or get gasoline in your eye(s), see your doctor immediately. If any gasoline spills on your skin or clothing, immediately wash with soap and water and change your clothes.

# CONTENTS

OFF-ROAD LIMITED WARRANTY . . . . .	1-1
LOCATION OF IMPORTANT LABELS . . . . .	2-1
DESCRIPTION . . . . .	3-1
MACHINE IDENTIFICATION . . . . .	4-1
Vehicle identification number. . . . .	4-1
Engine serial number. . . . .	4-1
CONTROL FUNCTIONS . . . . .	5-1
Handlebar switches. . . . .	5-1
Indicator light . . . . .	5-1
Clutch lever . . . . .	5-3
Shift pedal . . . . .	5-4
Front brake lever. . . . .	5-4
Rear brake pedal. . . . .	5-5
Fuel tank cap . . . . .	5-5
Fuel cock . . . . .	5-6
Starter knob (CHOKE) . . . . .	5-7
Kick starter . . . . .	5-7
Right side cover . . . . .	5-8
Seat . . . . .	5-8

Rear shock absorber . . . . .	5-9
Yamaha Energy Induction System (Y.E.I.S.) . . . . .	5-10
PRE-OPERATION CHECKS . . . . .	6-1
Brakes . . . . .	6-3
Brake fluid leakage . . . . .	6-4
Clutch . . . . .	6-4
Throttle grip . . . . .	6-4
Engine oil . . . . .	6-4
Transmission oil . . . . .	6-5
Chain . . . . .	6-5
Tires . . . . .	6-6
Wheels . . . . .	6-8
Accessories or replacement parts . . . . .	6-8
Fitting/Fasteners . . . . .	6-9
Light . . . . .	6-9
Switches . . . . .	6-9
Fuel . . . . .	6-9
Gasohol . . . . .	6-10



<b>OPERATION AND IMPORTANT</b>	
<b>RIDING POINTS</b> .....	<b>.7-1</b>
Starting and warming up a cold engine .....	<b>.7-2</b>
Starting a warm engine.....	<b>.7-2</b>
Shifting .....	<b>.7-3</b>
Engine break-in .....	<b>.7-4</b>
Parking.....	<b>.7-5</b>
<b>PERIODIC MAINTENANCE AND</b>	
<b>MINOR REPAIR.....</b>	<b>.8-1</b>
Tool kit.....	<b>.8-1</b>
Periodic maintenance/lubrication ....	<b>.8-3</b>
Torque specifications .....	<b>.8-5</b>
Engine oil .....	<b>.8-6</b>
Transmission oil level check .....	<b>.8-6</b>
Transmission oil replacement .....	<b>.8-7</b>
Air filter .....	<b>.8-8</b>
Carburetor adjustment .....	<b>.8-10</b>
Idle speed adjustment.....	<b>.8-10</b>
Throttle cable adjustment.....	<b>.8-11</b>
Sparg plug inspection .....	<b>.8-12</b>
Front brake adjustment .....	<b>.8-14</b>
Rear brake adjustment .....	<b>.8-15</b>
Cheking the front brake pads and rear brake shoes .....	<b>.8-17</b>
Inspecting the brake fluid level ....	<b>.8-18</b>
Brake fluid replacement .....	<b>.8-19</b>
Clutch adjustment.....	<b>.8-19</b>
Free play adjustment .....	<b>.8-19</b>
Drive chain slack check .....	<b>.8-20</b>
Drive chain slack adjustment .....	<b>.8-21</b>
Drive chain lubrication .....	<b>.8-23</b>
Cable inspection and lubrication....	<b>.8-23</b>
Throttle cable and grip lubrication..	<b>.8-24</b>
Autolube pump adjustment .....	<b>.8-24</b>
Brake and change pedals .....	<b>.8-24</b>
Brake and clutch levers .....	<b>.8-24</b>
Sidestand .....	<b>.8-24</b>
Rear suspension .....	<b>.8-25</b>
Front fork inspection .....	<b>.8-25</b>
Rear shock absorber .....	<b>.8-26</b>
Rear shock absorber adjustment....	<b>.8-27</b>
Steering inspection .....	<b>.8-28</b>
Wheel bearings .....	<b>.8-29</b>

Front wheel removal . . . . .	8-29
Front wheel instalation . . . . .	8-30
Rear wheel removal . . . . .	8-31
Rear wheel installation . . . . .	8-32
Troubleshooting . . . . .	8-33
Troubleshooting chart . . . . .	8-34
CLEANING AND STORAGE . . . . .	9-1
A. Cleaning . . . . .	9-1
B. Storage . . . . .	9-2
SPECIFICATION . . . . .	10-1
MOTORCYCLE NOISE REGULATION . . . . .	11-1
MAINTENANCE RECORD . . . . .	12-1
WIRING DIAGRAM RT180A . . . . .	13-1



# YAMAHA MOTOR CORPORATION, U.S.A.

## OFF-ROAD MOTORCYCLE LIMITED WARRANTY

Yamaha Motor Corporation, U.S.A. hereby warrants that each new Yamaha off-road motorcycle purchased from an authorized Yamaha motorcycle dealer in the continental United States will be free from defects in material and workmanship for the period of time stated herein, subject to certain stated limitations.

**THE PERIOD OF WARRANTY** for Yamaha off-road motorcycles shall be ninety (90) days from the date of purchase, with no mileage limitation.

**MODELS EXCLUDED FROM WARRANTY** include those machines used for non-Yamaha-authorized renting, leasing, or other commercial purposes.

**DURING THE PERIOD OF WARRANTY** any authorized Yamaha motorcycle dealer will, free of charge, repair or replace, at Yamaha's option, any part adjudged defective by Yamaha due to faulty workmanship or material from the factory. Parts used in warranty repairs will be warranted for the balance of the product's warranty period. All parts replaced under warranty become property of Yamaha Motor Corporation U.S.A.

**GENERAL EXCLUSIONS** from this warranty shall include any failures caused by:

- a. Competition or racing use (except TY models used for sanctioned trials).
- b. Installation of parts or accessories that are not qualitatively equivalent to genuine Yamaha parts.
- c. Abnormal strain, neglect, or abuse.
- d. Lack of proper maintenance.
- e. Accident or collision damage.
- f. Modification to original parts.

**SPECIFIC EXCLUSIONS** from this warranty shall include parts replaced due to normal wear or routine maintenance.

**THE CUSTOMER'S RESPONSIBILITY** under this warranty shall be to:

1. Operate and maintain the motorcycle as specified in the appropriate Owner's Manual, and
2. Give notice to an authorized Yamaha motorcycle dealer of any and all apparent defects within ten (10) days after discovery, and make the machine available at that time for inspection and repairs at such dealer's place of business.

**WARRANTY TRANSFER:** To transfer the warranty from the original purchaser to any subsequent purchaser, it is imperative that the machine be inspected and registered for warranty by an authorized Yamaha motorcycle dealer. In order for this warranty to remain in effect, this inspection and registration must take place within ten (10) days after transfer. An inspection and registration fee will be charged for this service.

**YAMAHA MOTOR CORPORATION, U.S.A. MAKES NO OTHER WARRANTY OF ANY KIND, EXPRESSED OR IMPLIED. ALL IMPLIED WARRANTIES OF MERCHANTABILITY AND FITNESS FOR A PARTICULAR PURPOSE WHICH EXCEED THE OBLIGATIONS AND TIME LIMITS STATED IN THIS WARRANTY ARE HEREBY DISCLAIMED BY YAMAHA MOTOR CORPORATION, U.S.A. AND EXCLUDED FROM THIS WARRANTY.**

**SOME STATES DO NOT ALLOW LIMITATIONS ON HOW LONG AN IMPLIED WARRANTY LASTS, SO THE ABOVE LIMITATION MAY NOT APPLY TO YOU. ALSO EXCLUDED FROM THIS WARRANTY ARE ANY**

**INCIDENTAL OR CONSEQUENTIAL DAMAGES INCLUDING LOSS OF USE. SOME STATES DO NOT ALLOW THE EXCLUSION OR LIMITATION OF INCIDENTAL OR CONSEQUENTIAL DAMAGES, SO THE ABOVE EXCLUSION MAY NOT APPLY TO YOU.**

**THIS WARRANTY GIVES YOU SPECIFIC LEGAL RIGHTS, AND YOU MAY ALSO HAVE OTHER RIGHTS WHICH VARY FROM STATE TO STATE.**

YAMAHA MOTOR CORPORATION, U.S.A.  
P. O. Box 6555  
Cypress, California 90630

## WARRANTY QUESTIONS AND ANSWERS

- Q. What costs are my responsibility during the warranty period?
- A. The customer's responsibility includes all costs of normal maintenance services, non-warranty repairs, accident and collision damages, and oil, oil filters, air filters, spark plugs, and brake shoes.
- Q. What are some examples of "abnormal" strain, neglect, or abuse?
- A. These terms are general and overlap each other in areas. Specific examples include: Running the machine out of oil; sustained high-rpm, full-throttle use; operating the machine with a broken or damaged part which causes another part to fail; damage or failure due to improper or careless transportation and or tie down; and so on. If you have any specific questions on operation or maintenance, please contact your dealer for advice.
- Q. Does the warranty cover incidental costs such as towing or transportation due to a failure?
- A. No. The warranty is limited to repair of the machine itself.
- Q. May I perform any or all of the recommended maintenance shown in the Owner's Manual instead of having the dealer do them?
- A. Yes, if you are a qualified mechanic and follow the procedures specified in the Owner's and Service Manual. We do recommend, however, that items requiring special tools or equipment be done by a Yamaha motorcycle dealer.
- Q. Will the warranty be void or cancelled if I do not operate or maintain my new motorcycle exactly as specified in the Owner's Manual?
- A. No. The warranty on a new motorcycle cannot be "voided" or "cancelled." **However, if a particular failure is caused by operation or maintenance other than as shown in the Owner's Manual, that failure may not be covered under warranty.**
- Q. What responsibility does my dealer have under this warranty?
- A. Each Yamaha motorcycle dealer is expected to:
1. Completely set up every new machine before sale.
  2. Explain the operation, maintenance, and warranty requirements to your satisfaction at the time of sale, and upon your request at any later date.
- In addition, each Yamaha motorcycle dealer is held responsible for his setup, service and warranty repair work.
- Q. Is the warranty transferable to second owners?
- A. Yes. The remainder of the existing warranty can be transferred upon request. The unit has to be inspected and re-registered by an authorized Yamaha motorcycle dealer for the policy to remain effective.

## CUSTOMER SERVICE

If your machine requires warranty service, you must take it to any authorized Yamaha motorcycle dealer within the continental United States. Be sure to bring your warranty registration identification or other valid proof of the original date of purchase. If a question or problem arises regarding warranty, first contact the owner of the dealership. Since all warranty matters are handled at the dealer level, this person is in the best position to help you. If you are still not satisfied and require additional assistance, please write:

YAMAHA MOTOR CORPORATION U.S.A.  
CUSTOMER RELATIONS DEPARTMENT  
P.O. Box 6555  
Cypress, California 90630

When contacting Yamaha Motor Corporation, U.S.A. don't forget to include any important information such as names, addresses, model, engine serial number, dates, and receipts.

## CHANGE OF ADDRESS

The federal government requires each manufacturer of a motor vehicle to maintain a complete, up-to-date list of all first purchasers against the possibility of a safety-related defect and recall. This list is compiled from the purchase registrations sent to Yamaha Motor Corporation, U.S.A. by the selling dealer at the time of your purchase.

If you should move after you have purchased your new motorcycle, please advise us of your new address by sending a postcard listing your motorcycle model name, engine serial number, dealer number (or dealer's name) as it is shown on your warranty identification, your name and new mailing address.  
Mail to:

YAMAHA MOTOR CORPORATION, U.S.A.  
WARRANTY DEPARTMENT  
P.O. Box 6555  
Cypress, California 90630

This will ensure that Yamaha Motor Corporation, U.S.A. has an up-to-date registration record in accordance with federal law.



# LOCATION OF THE IMPORTANT LABELS

Please read following labels carefully before operating this machine.



①

## TIRE INFORMATION

Cold tire pressure should be set as follows:

FRONT : 100kPa, (1.00kgf/cm<sup>2</sup>), 15 psi  
REAR : 100kPa, (1.00kgf/cm<sup>2</sup>), 15 psi

YAMAHA

JPT-21054-00

②

## WARNING

This unit contains high pressure nitrogen gas.

Mishandling can cause explosion.

- Read owner's manual for instructions.
- Do not incinerate, puncture or open.

YAMAHA

JTW-22280-00

③

MOTORCYCLE NOISE EMISSION CONTROL INFORMATION : YAMAHA MOTOR DA AMAROMA LTDA **YAMAHA**  
THIS MOTORCYCLE MEETS 1980 AND LATER EPA NOISE EMISSION REQUIREMENTS OF THE FEDERAL TEST PROCEDURE MODIFICATIONS  
WHICH CAUSE THIS MOTORCYCLE TO EXCEED FEDERAL NOISE STANDARDS ARE PROHIBITED BY FEDERAL LAW SEE OWNER'S MANUAL  
LIMIT/CLOSING : 82 #A/ 8644 1/11# MODEL CODE YAM3VC0176 3VC-2179X-00

# DESCRIPTION

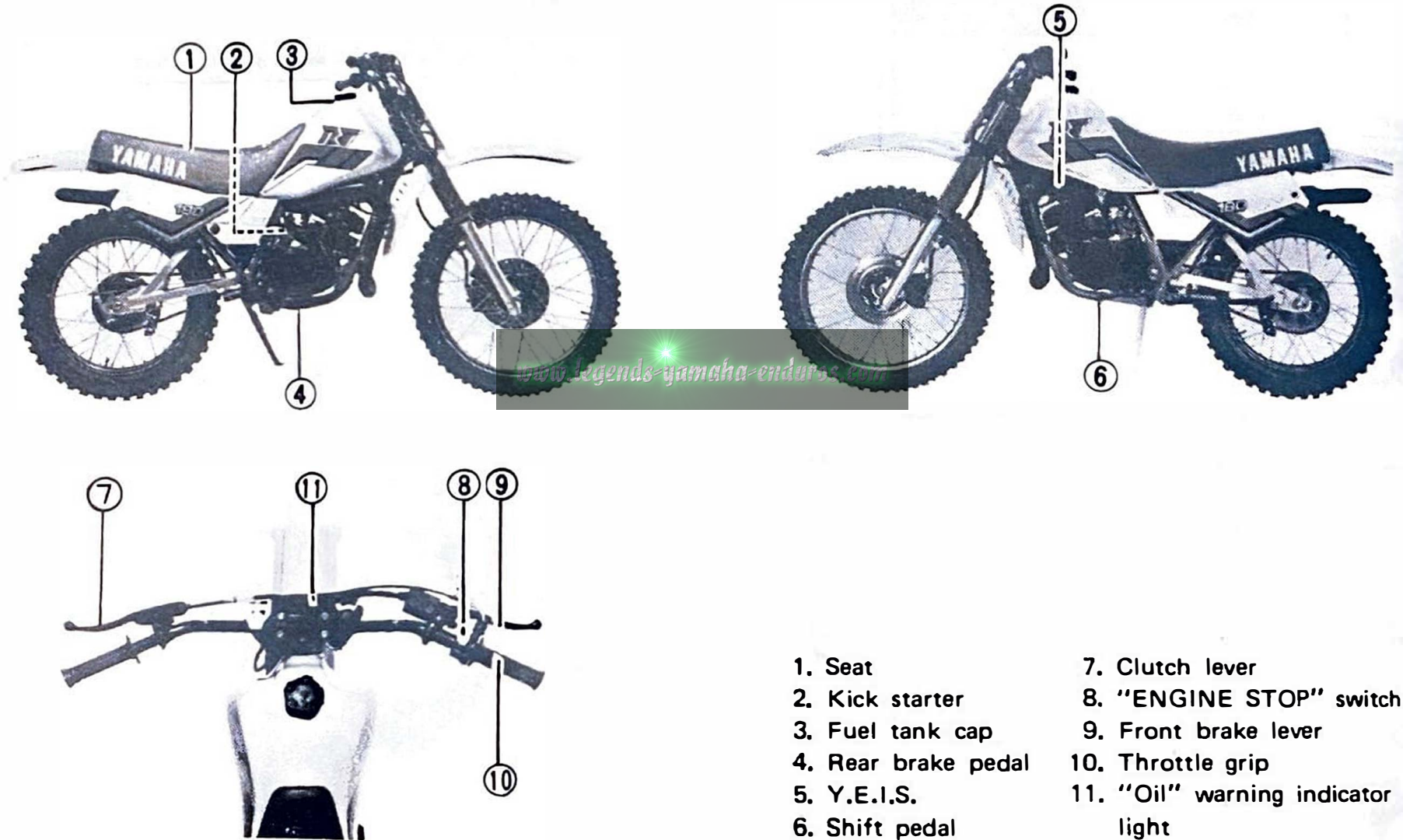

- 1. Seat
- 2. Kick starter
- 3. Fuel tank cap
- 4. Rear brake pedal
- 5. Y.E.I.S.
- 6. Shift pedal
- 7. Clutch lever
- 8. "ENGINE STOP" switch
- 9. Front brake lever
- 10. Throttle grip
- 11. "Oil" warning indicator light



A-60

# MACHINE IDENTIFICATION

A-800

## Vehicle identification number

The vehicle identification number is stamped into the steering head pipe.

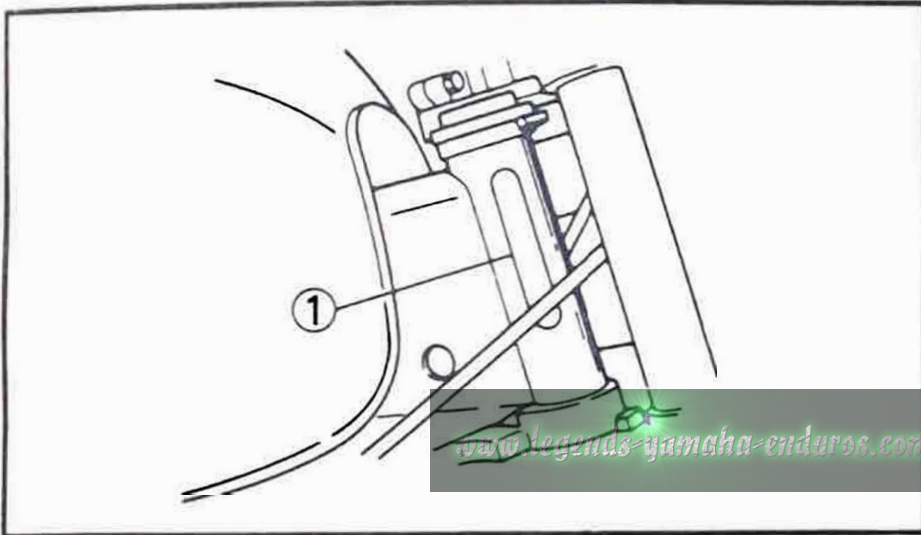

1. Vehicle identification number

U-004

**NOTE:** \_\_\_\_\_

The vehicle identification number is used to identify your machine

---

A-701

## Engine serial number

The engine serial number is stamped into the right side of the engine.

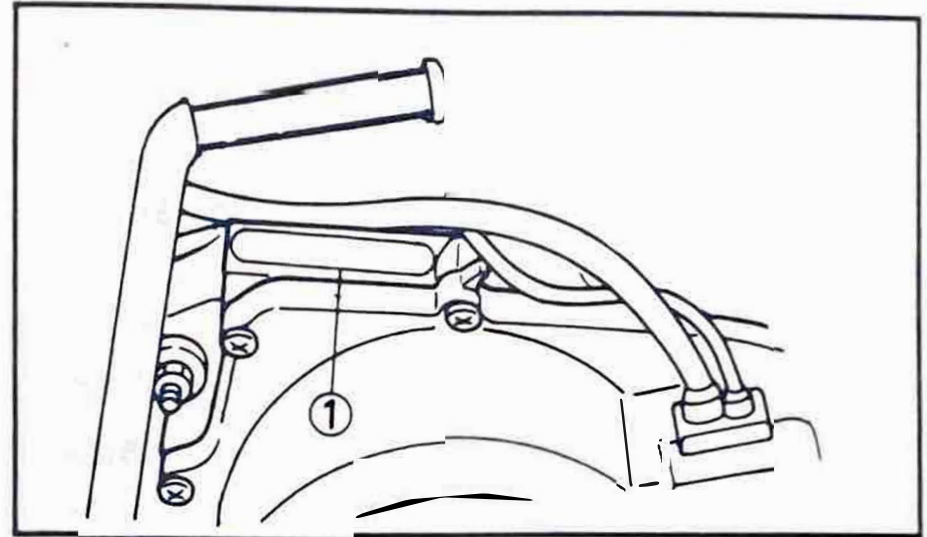

1. Engine serial number

U-003

**NOTE:** \_\_\_\_\_

The first three digits of this number is for model identification; the remaining digits are the unit production number. Keep a record of this number for reference when ordering parts from a Yamaha dealer.

---

# CONTROL FUNCTIONS

## Handlebar switch:

### "ENGINE STOP" switch

The engine stop switch is located on the right handlebar.

This switch controls the ignition system.

**RUN:** The engine can be started in this position.

**OFF:** The engine can be stopped in this position. Also the engine cannot be started.

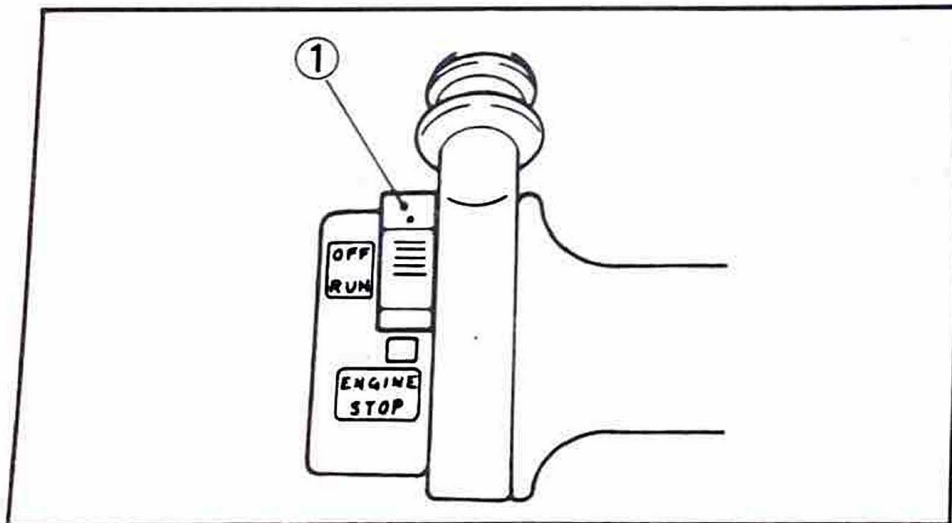

1. "ENGINE STOP" switch

## Indicator lights

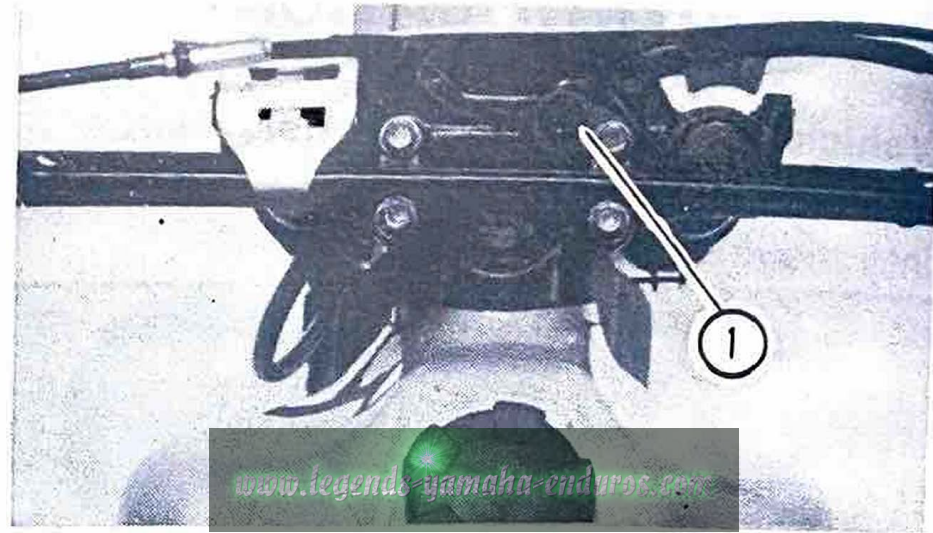

1. "Oil" warning indicator light

### "OIL" warning indicator light (red):

This indicator comes on when the oil level is low. This light circuit can be checked by the following procedure.

## CAUTION:

**Do not run the machine until you know the machine has enough engine oil.**

## Oil warning light checking method

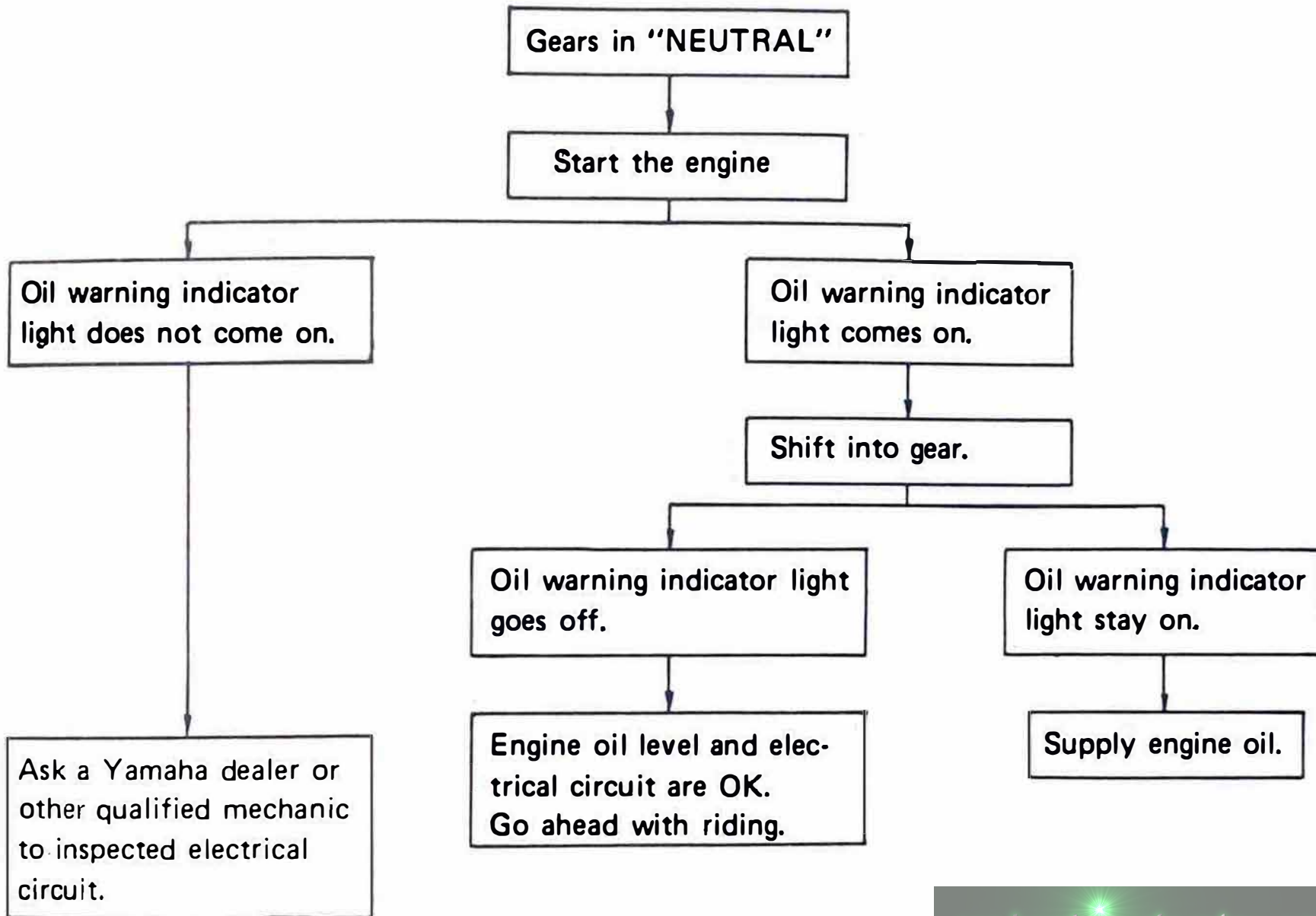

## Clutch lever

The clutch lever is located on the left hand-lebar; it disengages or engages the clutch. Pull the clutch lever to the handlebar to disengage the clutch, and release the lever to engage the clutch. The lever should be pulled rapidly and released slowly for smooth starts.



1. Clutch lever



B-800

## Shift pedal

The gear ratios of the constant-mesh 5-speed transmission are ideally spaced. The gears can be shifted by using the shift pedal on the left side of the engine.

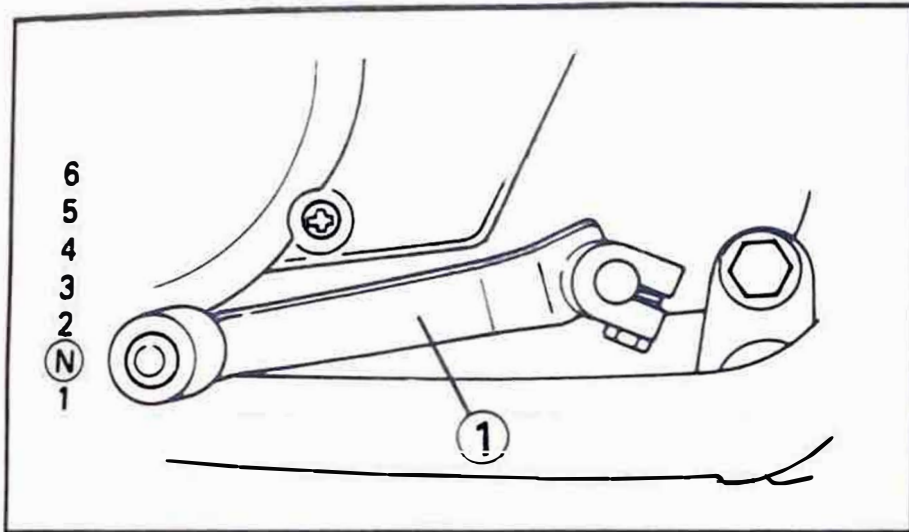

1. Shift pedal    N. Neutral

B-900

## Front brake lever

The front brake lever is located on the right handlebar. Pull it toward the handlebar to activate the front brake.

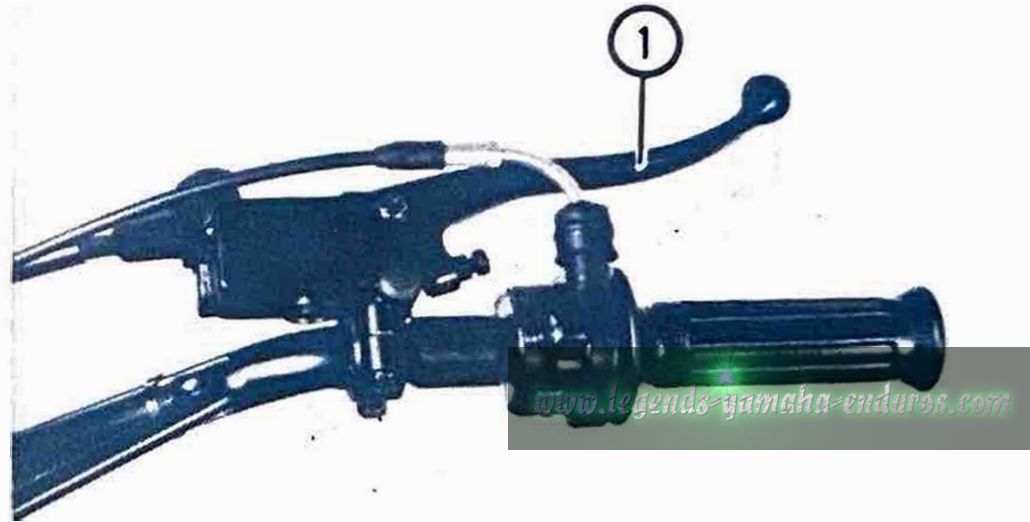

1. Front brake lever



### Rear brake pedal

The rear brake pedal is on the right side of the machine. Press down on the brake pedal to activate the rear brake,

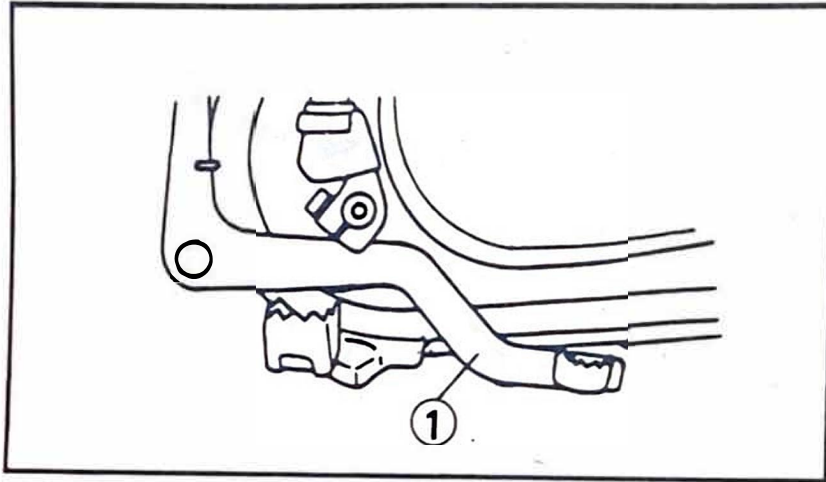

1. Rear brake pedal

### Fuel tank cap

Remove the fuel tank cap by turning it counterclockwise.

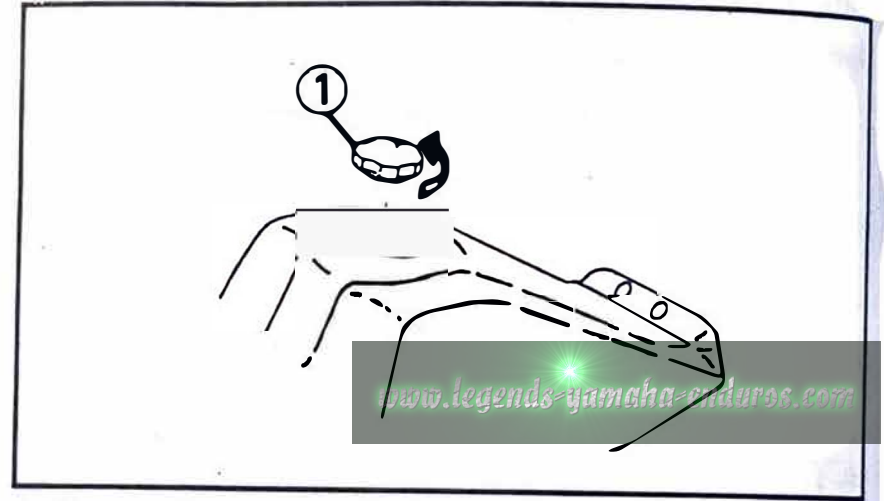

1. Fuel tank cap

## Fuel cock

The fuel cock supplies fuel from the tank to carburetor while filtering the fuel. The fuel cock has the three positions:

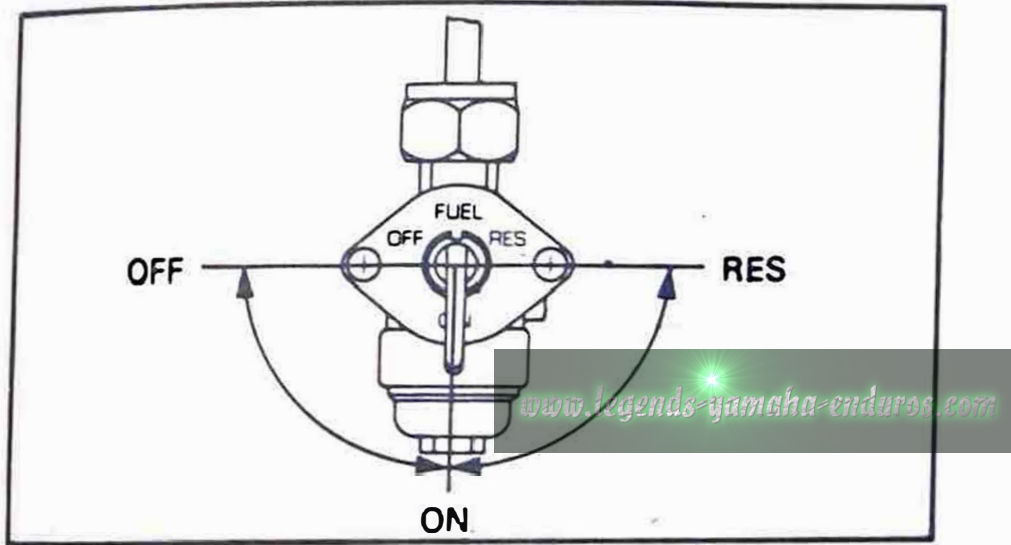

**RES:** This indicates reserve. If you run out of fuel while riding, move the lever to this position. FILL THE TANK AT THE FIRST OPPORTUNITY. BE SURE TO SET THE LEVER TO "ON" AFTER REFUELING.

**OFF:** With the lever in this position, fuel will not flow. Always return the lever to this position when the engine is not running.

**ON:** With the lever in this position, fuel flows to the carburetor. Normal riding is done with the lever in this position.

## Starter knob (CHOKE)

When cold, the engine requires a richer air-fuel mixture for starting. A separate starter circuit supplies this mixture. Pull the starter knob out to open the circuit for starting. When the engine has warmed up, push the knob in to close the circuit.

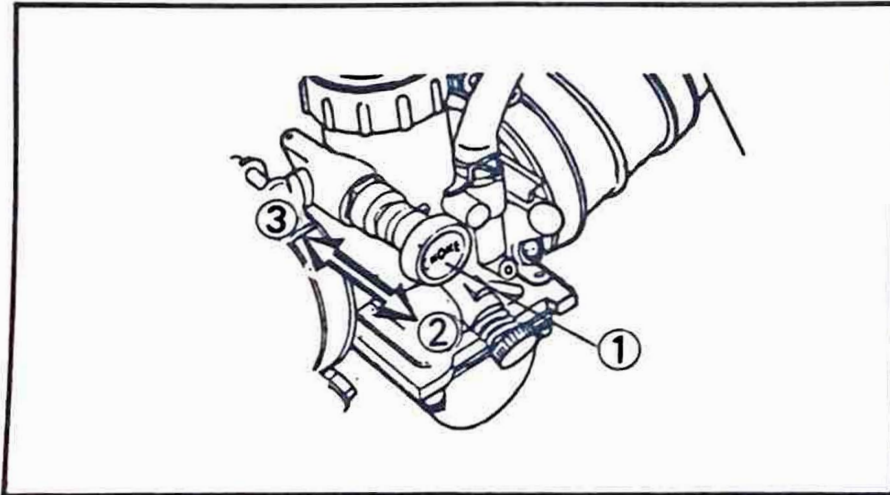

1. Starter knob    2. Open the circuit    3. Close the circuit

## Kick starter

Rotate the kick starter away from the engine. Push the starter down lightly with your foot until the gears engage, then kick smoothly and forcefully to start the engine. This model has a primary kick starter so the engine can be started in any gear if the clutch is disengaged. In normal practices, however, shift to neutral before starting.

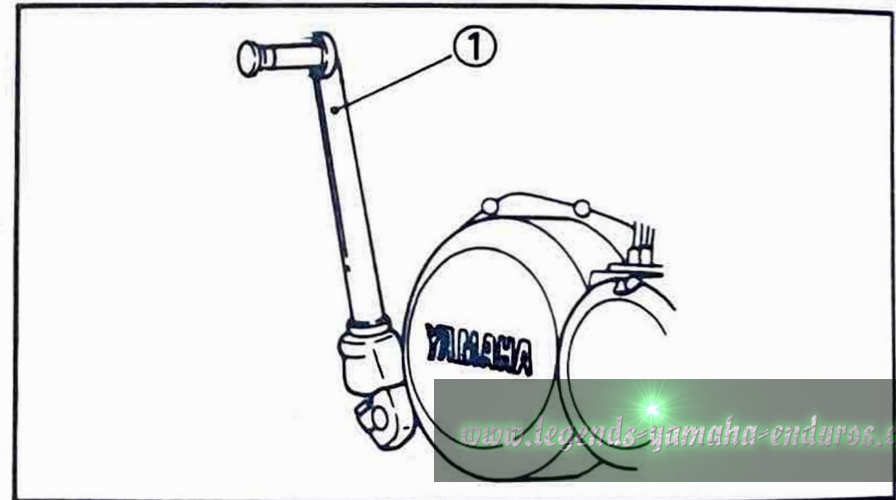

1. Kick starter

## Right side cover

Turn the lock knob clockwise:

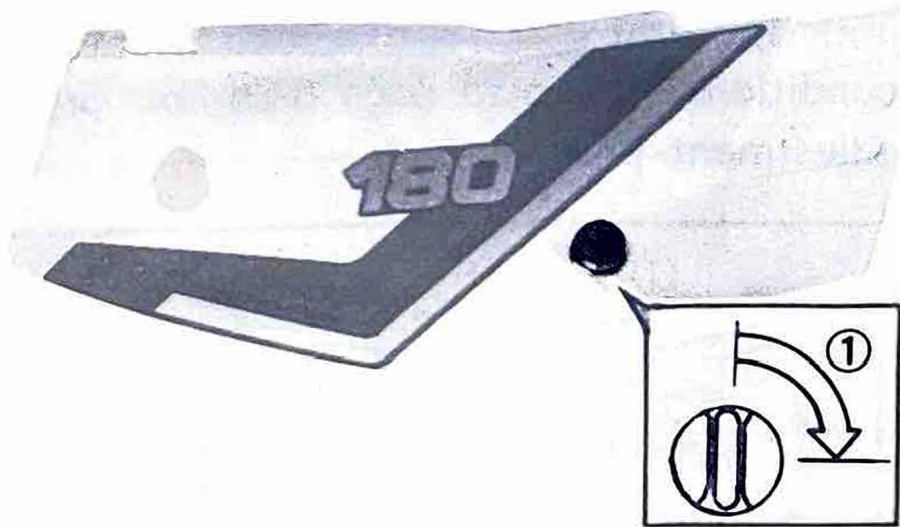

1. Open

Remove the side cover by pulling out the knobs.

## Seat

To remove the seat:

Remove both side covers and remove the bolts, then pull up the seat at the rear.





To install the seat:

Insert the lobe on the seat front into the receptacle on the frame, then push down the seat at the rear and tighten the bolts. Install the both side covers.

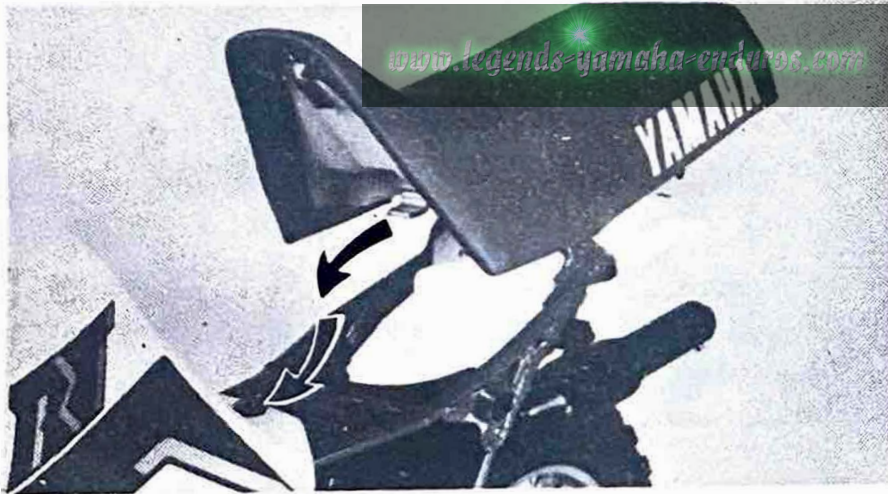

C-902

### Rear shock absorber

The spring preload of the rear shock absorber can be adjusted to suit machine's load (ex: optional accessories etc.) and riding conditions. Refer to page 8-26 for proper adjustment procedures.

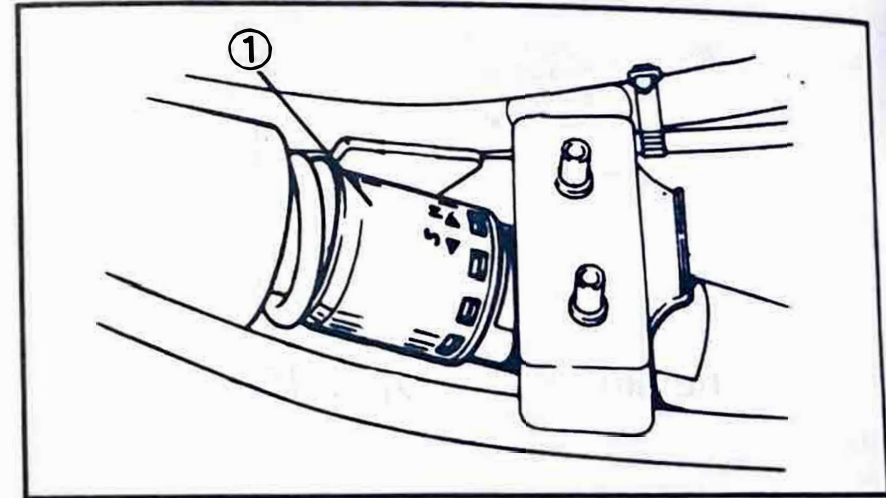

1. Rear shock absorber

### **WARNING**

**Make sure that the seat is securely fitted.**

## **Yamaha Energy Induction System (Y.E.I.S.)**

Y.E.I.S. helps to improve the flow of the air - fuel mixture into the engine for better performance. It has no moving parts and requires no maintenance.

**Never attempt to modify the Yamaha Energy Induction System.**

**Improper installation or damage parts will result in a poor performance.**

**Replace any cracked or damaged parts immediately.**

---

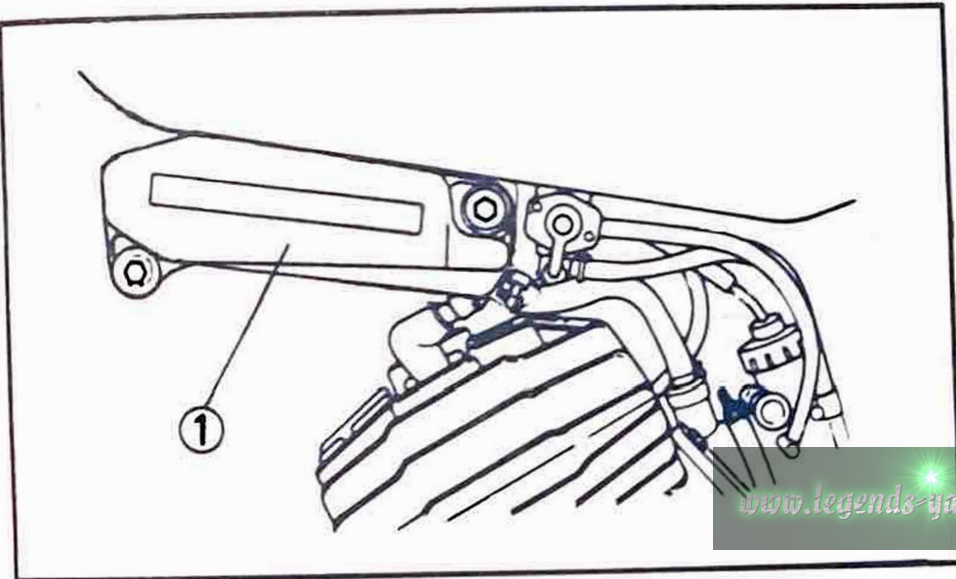

1. Y.E.I.S.

# PRE-OPERATION CHECKS

Before using this machine check the following points:

Item	Routine	Page
Front brake	Check operation, free play, fluid leakage and fluid level. Top-up with DOT#4 (or DOT#3) brake fluid if necessary.	6-3~6-4, 8-14 8-17~8-19
Rear brake	Check operation, condition and free play. Adjust if necessary.	6-3, 8-15~8-17
Clutch	Check operation, condition and free play, Adjust if necessary.	6-4, 8-19
Throttle grip/Housing	Check for smooth operation. Lubricate/Adjust if necessary.	6-4, 8-11~8-12, 8-23
Autolube tank	Check oil level/top-up as required.	6-4~6-5, 8-6
Transmission oil	Check oil level/top-up as required.	6-5, 8-6~8-8
Drive chain	Check chain slack and condition. Adjust if necessary.	6-5, 8-20~8-22
Wheels/Tires	Check tire pressure, wear, damage.	6-6~6-8, 8-29~8-32
Control/Cables	Check for smooth operation. Lubricate if necessary.	8-23
Brake and change pedal shifts	Check for smooth operation. Lubricate if necessary.	8-24
Brake and clutch lever pivots	Check for smooth operation. Lubricate if necessary.	8-24
Sidestand pivot	Check for smooth operation. Lubricate if necessary.	8-24
Fitting/Fasteners	Check all chassis fitting and fasteners. Tighten/Adjust if necessary.	6-9, 8-5
Fuel tank	Check fuel level/top-up as required.	6-9~6-10
Light	Check operation.	6-9

**NOTE:**

Pre-operation checks should be made each time the machine is used. Such an inspection can be thoroughly accomplished in a very short time; and the added safety it assures is more than worth the time involved.

**! WARNING**

If any item in the Pre-Operation Check is not working properly, have it inspected and repaired before operating the machine.



## Brakes (See page 8 - 14 for details)

1. Brake lever and brake pedal  
Check for correct free play in the front brake lever and rear brake pedal. Make sure they are working properly. Check the brakes at low speed shortly after starting out. If the free play is incorrect, adjust it.

U-622

### **WARNING**

A soft, spongy feeling in the brake lever indicates a failure in the brake system. Do not operate the machine until the failure in the brake system is corrected. Ask a Yamaha dealer or other qualified mechanic for immediate repairs. A soft, spongy feeling could indicate a hazardous condition in the brake system.

2. Brake fluid  
Check the brake fluid level.  
Add fluid if necessary.

Recommended brake fluid: DOT # 4

**NOTE:** \_\_\_\_\_  
If DOT #4 is not available, #3 can be used.

3. Check the disc pads.  
Refer to page 8-17.
4. Check the brake shoes.  
Refer to page 8-17.

U-021

**NOTE:** \_\_\_\_\_  
When this brake service is necessary, ask a Yamaha dealer or other qualified mechanic.

E-112

### **Brake fluid leakage (Front)**

Apply the brake for a few minutes. Check to see if any brake fluid leaks out from the pipe joints or the master cylinder.

U-624

### **! WARNING**

If brake fluid leakage is found, ask a Yamaha dealer or other qualified mechanic for immediate repairs. Such leakage could indicate a hazardous condition.

E-200

### **Clutch (See page 8 - 19 for details)**

Check the free play in the clutch lever, and make sure the lever operates properly. If the free play is incorrect, adjust it.

E-300

### **Throttle grip (See page 8 - 11 for details)**

Turn the throttle grip to see if it operates properly, and check the free play. Make sure the grip returns by spring force when released. Ask a Yamaha dealer or other qualified mechanic to make any necessary adjustments.

E-409

### **Engine oil**

Make sure the engine oil is at the specified level. Add oil as necessary.

#### **Recommended oil:**

Yamalube 2-cycle oil or air-cooled 2-stroke engine oil with "BIA certified for service TC-W".

#### **Oil quantity:**

**Total amount**

**0.75 L (0.66 Imp qt, 0.79 US qt)**

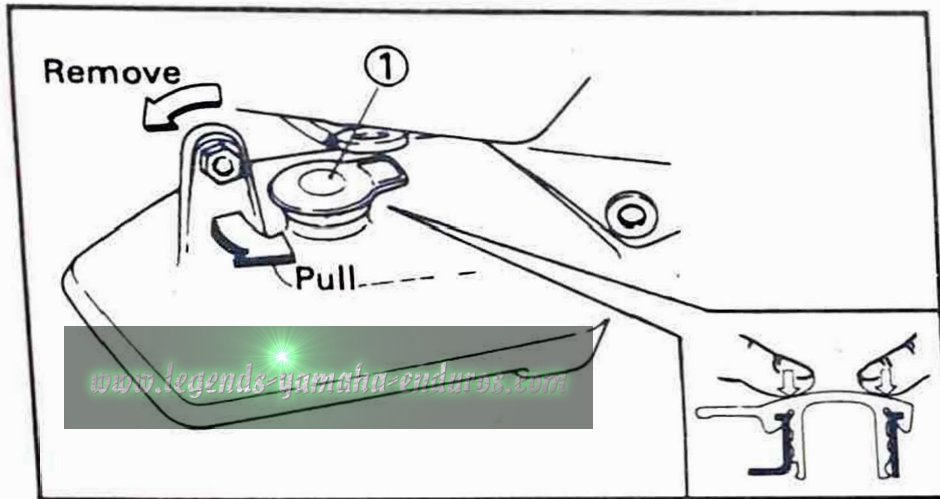

1. Oil tank filler cap

U-042

**NOTE:** \_\_\_\_\_

Be sure to push the cap into the filler neck until it is properly seated.

\_\_\_\_\_

E-404

**Transmission oil (See page 8-6 for more details)**

Make sure the transmission oil is at the specified level. Add oil as necessary.

**Recommended oil:**

Yamalube 4(10W30) or SAE 10W30 type SE motor oil

**Oil quantity:**

**Total amount:**

0.60 L(0.53 Imp qt, 0.63 US qt)

**Periodic oil change:**

0.55 L(0.48 Imp qt, 0.58 US qt)

E-500

**Chain (See page 8 - 20 for details)**

Check the general condition of the chain and check the chain slack before every ride.

Lubricate and adjust the chain as necessary.

## Tires

To ensure maximum performance, long service, and safe operation, note the following:

### 1. Tire air pressure

Always check and adjust the tire pressure before operating the machine.

U-675

## **! WARNING**

**Tire inflation pressure should be checked and adjusted when the temperature of the tire equals the ambient air temperature.**

Operating tire pressure:  
Set pressure with tires cold.

	Front	Rear
Off-road riding	100 kPa (1.0 kgf/cm <sup>2</sup> ; 15 psi)	100 kPa (1.0 kgf/cm <sup>2</sup> , 15 psi)

## 2. Tire inspection

Always check the tires before operating the machine. If center tread depth reaches the limit as shown, if the tire has a nail or glass fragments in it, or if the side wall is cracked, contact a Yamaha dealer or other qualified mechanic immediately and have the tire replaced.

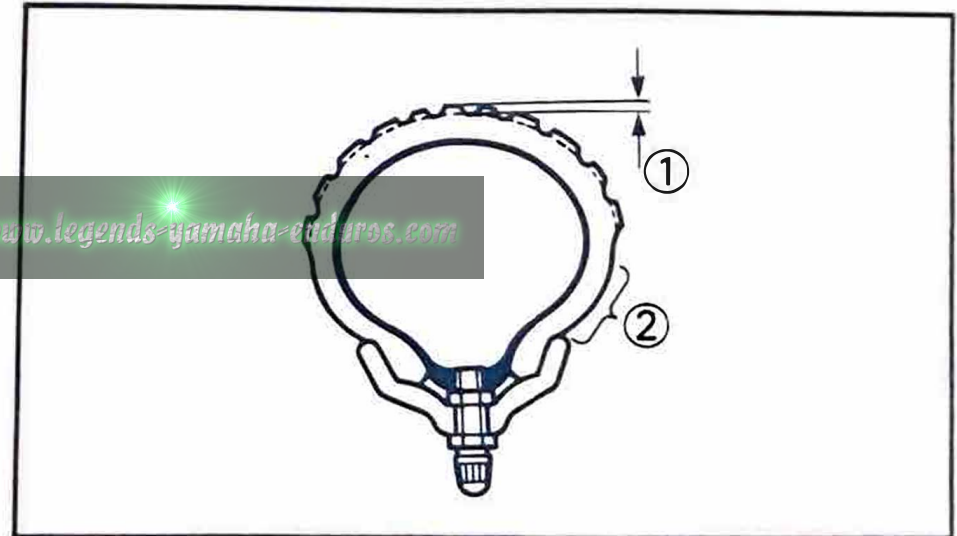

1. Tread depth      2. Side wall



**FRONT:**

Manufacture	Size	Type
Bridgestone	80/100-21	4PR

**REAR:**

Manufacture	Size	Type
Bridgestone	100/100-18	59M

Minimum tire tread depth (front and rear)	4.5 mm (11.4 in)
---	------------------

**WARNING**

1. **Operating the machine with excessively worn tires decrease riding stability and can lead to loss of control. Have excessively worn tires replaced by a Yamaha dealer immediately. Brakes, tires, and related wheel parts replacement should be left to a Yamaha Service Technician or other qualified mechanic.**
2. **Patching a punctured tube is not recommended. If it is absolutely necessary to do so, use great care and replace the tube as soon as possible with a good quality replacement.**

## Wheels

To ensure maximum performance, long service, and safe operation, note the following:

1. Always inspect the wheels before a ride. Check for cracks, bends, or warpage of the wheel; be sure the spokes are tight and undamaged. If any abnormal condition exists in a wheel, consult a Yamaha dealer or other qualified mechanic. Do not attempt even small repairs to the wheel. If a wheel is deformed or cracked, it must be replaced.
2. Tires and wheels should be balanced whenever either one is changed or replaced. Failure to have a wheel balanced can result in poor performance, adverse handling characteristics, and shortened tire life.
3. After installing a tire, ride conservatively to allow the tire to seat itself on the rim properly. Failure to allow proper seating may cause tire failure, resulting in damage to the machine and injury to the rider.

## Accessories or replacement parts

### **WARNING**

**This machine is not designed to pull a trailer or to be attached to a sidecar. The accessories or replacement parts you choose for your machine should be designed specifically for it, and they must be securely mounted to maintain the inherent stability of the original design. Genuine Yamaha Parts and Accessories are designed and tested to be compatible with your machine. Please consider Genuine Yamaha Parts and Accessories before making an accessory purchase. Use of non-Yamaha-approved parts or accessories may cause loss of handling stability and riding safety. Since Yamaha cannot control the quality of parts or accessories manufactured by other companies,**

**Yamaha cannot be held liable for any consequence caused by the use of items which have not been approved by Yamaha**

---

E-850

### **Fittings/Fasteners**

Always check the tightness of chassis fittings and fasteners before a ride. Use the chart on page 8-5 to find the correct torque.

### **Light**

Check the oil warning indicator light to make sure it is in working condition.

### **Switch**

Check the operation of the "ENGINE STOP" switch.

E-800

### **Fuel**

Make sure there is sufficient fuel in the tank.

U-610

## **! WARNING**

**Do not overfill the fuel tank. Avoid spilling fuel on the hot engine. Do not fill the fuel tank above the bottom of the filler tube as shown in the illustration or it may overflow when the fuel heats up later and expands.**

---

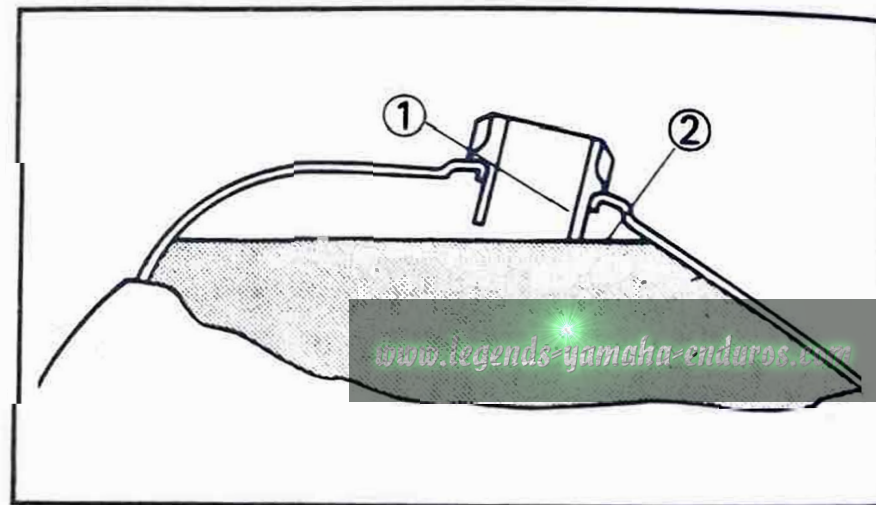

1. Filler tube

2. Fuel level

Recommended fuel

**UNLEADED FUEL RECOMMENDED**

Fuel tank capacity:

Total:

13 L (2.8 Imp qt, 3.4 US qt)

Reserve:

1.1 L (0.24 Imp qt, 0.29 US qt)

Your Yamaha engine has been designed to use regular unleaded gasoline with a pump octane number ( $(R+M)/2$ ) of 86 or higher, or research octane number of 91 or higher. If knocking or pinging occurs, use a different brand of gasoline or premium unleaded fuel. Unleaded fuel will give you longer spark plug life and reduced maintenance cost. If unleaded gasoline is not available, then leaded regular gasoline can be used.

## Gasohol

There are two types of gasohol; gasohol containing ethanol and that containing methanol. Gasohol containing ethanol can be used if ethanol content does not exceed 10%. Gasohol containing methanol is not recommended by Yamaha because it can cause fuel system damage or vehicle performance problems.



# OPERATION AND IMPORTANT RIDING POINTS

U-627

## WARNING

Before riding this machine, become thoroughly familiar with all operating controls and their function. Consult a Yamaha dealer or other qualified mechanic regarding any control or function that you do not thoroughly understand.

U-722

## WARNING

This model is designed for off-road use only. It is illegal to ride this model (either day or night) on any public street or highway.

## WARNING

1. Never start your engine or let it run for any length of time in a closed area. The exhaust fumes are poisonous and can cause loss of consciousness and death within a short time. Always operate your machine in an area with adequate ventilation.
2. Before starting out, always be sure the sidestand is up. Failure to retract the sidestand completely can result in a serious accident when you try to turn a corner.

F-129

### Starting and warming up a cold engine

1. Turn the fuel cock to "ON".
2. Shift transmission into neutral.
3. Operate the starter (CHOKE), and completely close the throttle grip.
4. Kick the kick starter to start the engine.
5. After starting the engine, turn back the starter knob (CHOKE) to warming up position (about halfway).

U-026

### NOTE: \_\_\_\_\_

To get maximum engine life, always warm up the engine before starting-off. Never accelerate hard with a cold engine!

---

6. After warming up the engine, turn off the starter knob by pushing it back completely.

U-027

### NOTE: \_\_\_\_\_

The engine is warm when it responds to the throttle normally with the starter turned off.

---

F-108

### Starting a warm engine

The starter (CHOKE) is not required when the engine is warm.

U-314

### CAUTION: \_\_\_\_\_

See "Break-in section" prior to operating the machine for the first time.

---

## Shifting

The transmission lets you control the amount of power you have available at a given speed for starting, accelerating, climbing hills, etc. The use of the shift pedal is shown in the illustration. (Page 5-4)

To shift into NEUTRAL, depress the change pedal repeatedly until it reaches the end of its travel (you will feel a stop when you are in first gear) then raise the pedal slightly.

U-315

### **CAUTION:**

1. **Do not coast for long periods with the engine off, and do not tow the machine a long distance. Even with gears in neutral, the transmission is only properly lubricated when the engine is running. Inadequate lubrication may damage the transmission.**

2. **Always use the clutch when changing gears. The engine, transmission, and driveline are not designed to withstand the shock of forced shifting and can be damaged by shifting without the clutch.**
- 

F-201

### **To start out and accelerate:**

1. Pull the clutch lever to disengage the clutch.
2. Shift into FIRST gear.
3. Open the throttle gradually, and at the same time, release the clutch lever slowly.
4. Once the machine has reached a high enough speed for you to shift to the next gear, close the throttle, and at the same time, quickly pull in the clutch lever.

5. Shift into **SECOND** gear. (Be careful not to shift into **NEUTRAL**.)
6. Open the throttle part way and gradually release the clutch lever.
7. Follow the same procedure when shifting to the next higher gear.

F-203

#### **To decelerate:**

1. Close the throttle, and apply the front and/or rear brakes to slow the machine.
2. Downshift through the gears as road speed decreases.  
Any time the engine is about to stall or runs very roughly, pull in the clutch and use the brakes to stop.
3. When the machine is almost completely stopped, shift into **NEUTRAL**.

#### **Engine break-in**

There is never a more important period, in the life of your machine, than the period between zero and 20 hours.

For this reason we ask that you carefully read the following material. Because the engine is brand new, you must not put an excessive load on it for the first several hours of running. During the first 20 hours the various parts in the engine wear and polish themselves to the correct operating clearances.

During this period prolonged full throttle operation, or any condition which might result in excessive heating of cylinder, must be avoided. However, momentary full throttle operation, under load (2 ~ 3 seconds maximum), does not harm the engine.

Each full throttle acceleration sequence should be followed with a substantial rest period for the engine by cruising at lower rpm so the engine can rid itself of the temporary build up of heat.



If any abnormality is noticed during this period, ask a Yamaha dealer or other qualified mechanic to check.

1. 0 ~ 10 hours:

Avoid continuous operation above half throttle. Allow a cooling off period of five to ten minutes after every hour of operation. Vary the speed of the machine from time to time. Do not operate it at one set throttle position.

2. 10 ~ 20 hours:

Avoid prolonged operation above 3/4 throttle. Allow the machine to rev freely through the gears but do not use full throttle at any time.

3. After break-in:

Avoid prolonged full throttle operation. Vary speeds occasionally.

## CAUTION:

If any engine trouble should occur during the break-in period, consult a Yamaha dealer or other qualified mechanic immediately.

### Parking

When parking the machine, stop the engine.

Turn the fuel cock to "OFF" whenever stopping the engine.

U-630

## WARNING

The muffler and exhaust pipe are hot. Park the machine in a place where pedestrians or children are not likely to touch the machine.

Do not park the machine on a slope or soft ground; the machine may overturn.

# PERIODIC MAINTENANCE AND MINOR REPAIR

Periodic inspection, adjustment, and lubrication will keep your machine in the safest and most efficient condition possible. Safety is an obligation of the machine owner. The maintenance and lubrication schedule chart should be considered strictly as a guide to general maintenance and lubrication intervals. **YOU MUST TAKE INTO CONSIDERATION THAT WEATHER, TERRAIN, GEOGRAPHICAL LOCATIONS, AND A VARIETY OF INDIVIDUAL USES ALL TEND TO DEMAND THAT EACH OWNER ALTER THIS TIME SCHEDULE TO SHORTER INTERVALS TO MATCH HIS ENVIRONMENT.** The most important points of machine inspection, adjustment, and lubrication are explained in the following pages.

## **WARNING**

**If you are not familiar with machine service, this work should be done by a Yamaha dealer or other qualified mechanic.**

### **Tool kit**

The service information included in this manual is intended to provide you, the owner, with the necessary information for completing some of your own preventive maintenance and minor repairs. The tools provided in the owner's tool kit are sufficient for most of these purposes; however a torque wrench is also necessary to properly tighten nuts and bolts.

**! WARNING**

Modifications to this machine not approved by Yamaha may cause loss of performance, excessive noise, or render it unsafe for use. Consult a Yamaha dealer or other qualified mechanic before attempting any changes.

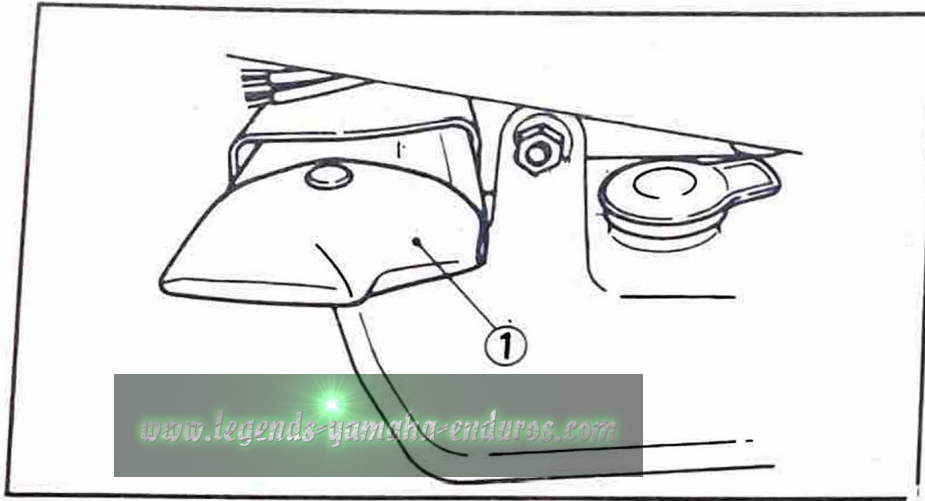

1. Tool kit

U-037

**NOTE:**

If you do not have a torque wrench available during a service operation requiring one, take your machine to a Yamaha dealer or other qualified mechanic to check the torque settings and adjust them as necessary.



# PERIODIC MAINTENANCE/LUBRICATION

ITEM	REMARKS	BREAK-IN 1 month	EVERY	
			6 months	12 months
Spark plug	Check condition. Clean or replace if necessary.	○	○	○
Air filter	Clean. Replace if necessary.	Every 20 ~ 40 hrs		
Carburetor*	Check idle speed/starter operation. Adjust if necessary.	○	○	○
Fuel line*	Check fuel hose for cracks or damage. Replace if necessary.		○	○
Transmission oil*	Check oil level/oil leakage. Correct if necessary. Replace every 6 months. (Warm engine before draining.)	REPLACE	○	○
Autolube pump*	Check operation. Correct if necessary. Air bleeding.	○	○	○
Front brake	Check operation/fluid leakage/See NOTE. Correct if necessary.		○	○
Rear brake *	Check operation. Adjust if necessary.		○	○
Clutch*	Check operation. Adjust if necessary.		○	○
Rear arm pivot*	Check rear arm assembly for looseness. Correct if necessary. Moderately repack every 24 months.**	○		○
Wheels*	Check balance/damage/runout/spoke tightness. Repair if necessary.		○	○
Wheel bearings*	Check bearings assembly for looseness/damage. Replace if damaged.		○	○
Steering bearing*	Check bearings assembly for looseness. Correct if necessary. Moderately repack every 24 months.**	○		○



ITEM	REMARKS	BREAK-IN 1 month	EVERY	
			6 months	12 months
Front forks*	Check operation/oil leakage. Repair if necessary.		○	○
Rear shock absorber*	Check operation/oil leakage. Repair if necessary.		○	○
Drive chain	Check chain slack/alignment. Adjust if necessary. Clean and lube.	Every ride (More often in wet or dusty areas)		
Fittings/Fasteners*	Check all chassis fittings and fasteners. Correct if necessary.	○	○	○
Sidestand*	Check operation. Repair if necessary.	○	○	○

\*: It is recommended that these items be serviced by a Yamaha dealer or other qualified mechanic.

\*\* : Medium weight wheel bearing grease.

**NOTE:** \_\_\_\_\_

**Brake fluid replacement:**

1. When disassembling the master cylinder or caliper cylinder, replace the brake fluid. Normally check the brake fluid level and add the fluid as required.
2. On the inner parts of the master cylinder and caliper cylinder, replace the seals every two years.
3. Replace the brake hoses every four years, or if cracked or damaged.

## Torque specifications

(For a more complete list, refer to the Service Manual for this model.)

Use a torque wrench to tighten these items. It is recommended that these items be checked regularly. Always check the tightness of these items whenever they are loosened for any reason.

A (Nut)	B (Bolt)	General torque specifications		
		Nm	m•kg	ft•lb
10 mm	6 mm	6	0.6	4.3
12 mm	8 mm	15	1.5	11
14 mm	10 mm	30	3.0	22
17 mm	12 mm	55	5.5	40
19 mm	14 mm	85	8.5	61
22 mm	16 mm	130	13.0	94

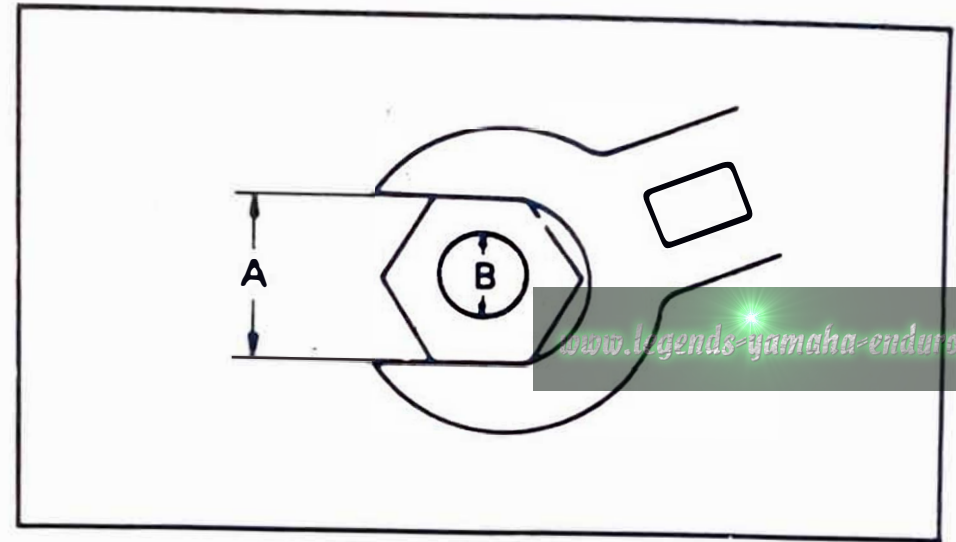

Item	Torque		
	Nm	m•kg	ft•lb
Spark plug	20	2.0	14
Drain plug—Transmission	43	4.3	31
Front wheel axle	85	8.5	61
Rear wheel axle	85	8.5	61

## Engine oil

1. Remove the right-hand side cover.
2. Make sure there is sufficient engine oil in the oil tank.

If necessary add engine oil.

### Recommended oil:

Yamalube 2-cycle oil or air-cooled 2-stroke engine oil with "BIA certified for service TC-W".

### Oil quantity:

Total amount

0.75 L (0.66 Imp. qt, 0.79 US qt)

H-403

## Transmission oil level check

1. To check the oil level, the machine must stand VERTICALLY with both wheels on the ground. A slight tilt toward the side can produce false readings.

2. When checking the oil level, stop the engine and remove the dipstick. Rest the dipstick on the threads of the hole

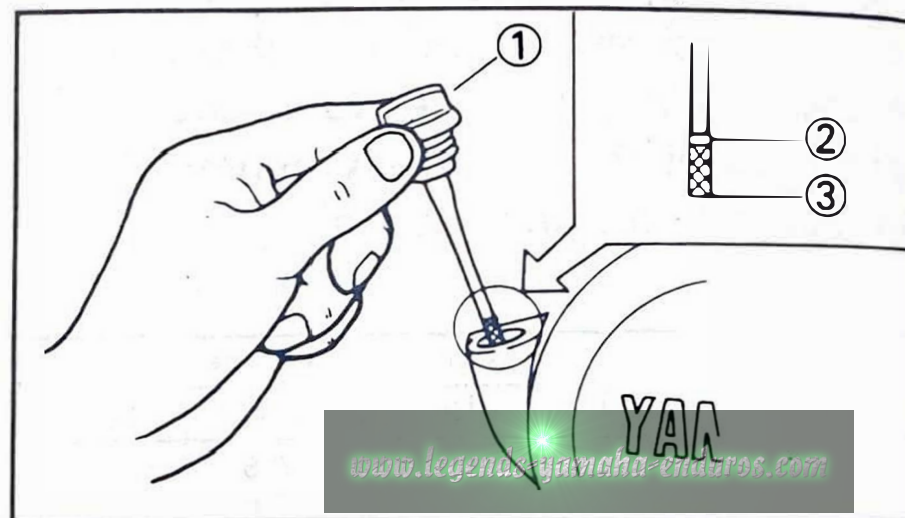

1. Dipstick 2. Maximum level 3. Minimum level

3. The dipstick has a minimum and maximum level; the oil level should be between the two. If the level is low add oil to raise it to the proper level.

Recommended oil:

Yamalube 4(10W30) or SAE 10W30  
type SE motor oil

Oil quantity:

0.60 L (0.53 Imp. qt, 0.63 US qt)

U-349

### CAUTION:

Do not add any chemical additives. Transmission oil also lubricates the clutch and additives could cause clutch slippage.

U-324

### CAUTION:

Be sure no foreign material enters the crankcase.

## Transmission oil replacement

1. To drain the oil, warm up the engine for several minutes.
2. Place an oil pan under the engine.
3. Remove the drain plug and drain the oil.

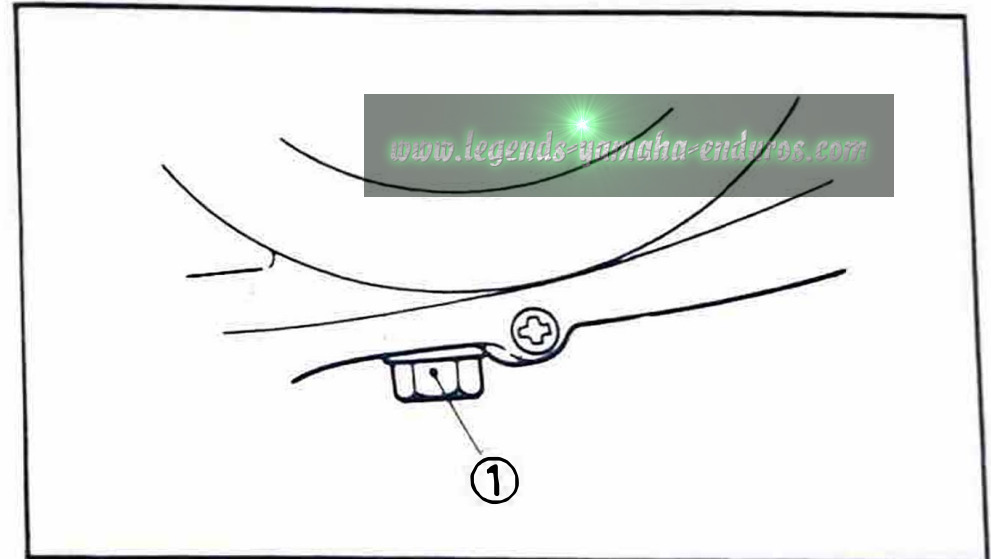

1. Drain plug

4. Reinstall the drain plug (make sure it is tight).

Drain plug torque:

43 Nm (4.3 m•kg, 31 ft•lb)



5. Add oil through the dipstick hole.

Periodic oil change:

0.55 L (0.48 Imp. qt, 0,58 US qt)

6. After replacement of transmission oil, be sure to check for oil leaks.

### Air filter

1. Remove the left-hand side cover.



2. Remove the air filter case cover.

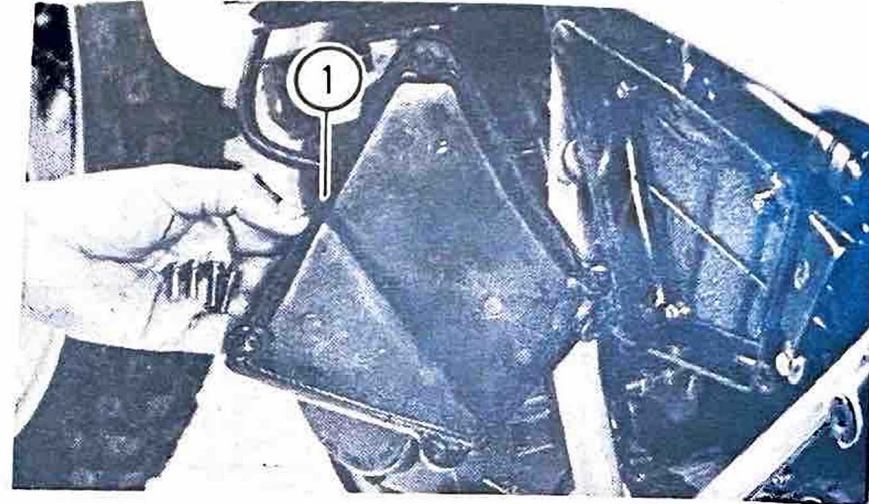

1. Air filter case cover

3. Remove the air filter element from its case.

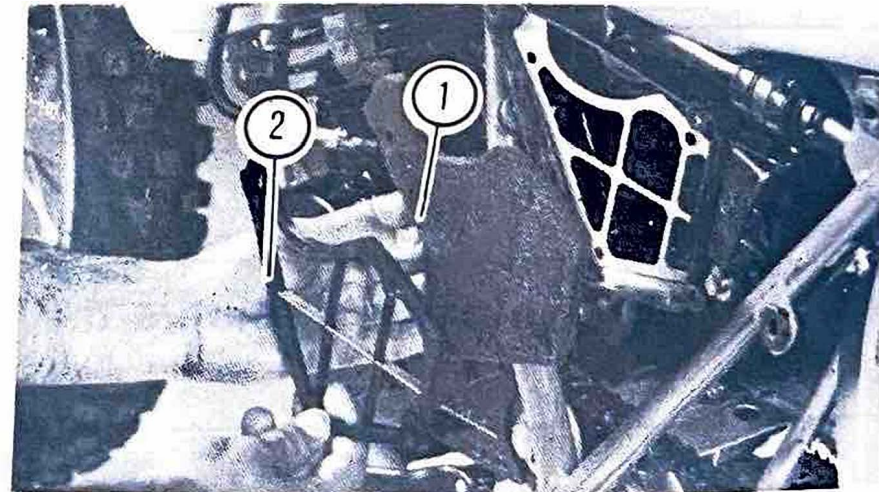

1. Air filter element 2. Element guide

4. Wash the element gently, but thoroughly, in solvent.

U-751K

**WARNING**

**Never use low flash point solvents such as gasoline to clean the element. Such solvent may lead to a fire or explosion.**

5. Squeeze the excess solvent out of the element and let dry.

U-412K

**CAUTION:**

**Do not twist the element when squeezing the element.**

6. Inspect the element. If damaged, replace it.

7. Apply Yamaha foam air filter oil or other quality foam air filter oil to the element. If foam air filter oil is not available, motor oil may be used.

U-115K

**NOTE:**

In order to function properly, the element must be damp with oil at all times, but not dripping with oil.

8. When installing the element in its case, be sure its sealing surface matches the sealing surface of the case so there is no air leak.
9. The element should be cleaned at the specified intervals. It should be cleaned and lubricated more often if the machine is operated in dusty or wet areas.



**NOTE:** \_\_\_\_\_

Each time element maintenance is performed, check the air inlet to the filter case for obstructions. Check the air cleaner joint rubber to the carburetor and manifold fittings for an air-tight seal. Tighten all fittings thoroughly to avoid the possibility of unfiltered air entering the engine.

---

**CAUTION:** \_\_\_\_\_

**Never operate the engine with the element removed. This will allow unfiltered air to enter, causing rapid wear and possible engine damage. Additionally, operation without the element will affect carburetor jetting with subsequent poor performance and possible engine overheating.**

---

**Carburetor adjustment**

The carburetor is a vital part of the engine. Adjusting should be left to a Yamaha dealer or other qualified mechanic with the professional knowledge, specialized data, and equipment to do so properly.

**NOTE:** \_\_\_\_\_

A diagnostic tachometer must be used for this procedure.

---

**Idle speed adjustment**

1. **Attach the tachometer.**

Start the engine and warm it up for a few minutes (normally, 1 or 2 minutes) at approximately 1,000 to 2,000 r/min. Occasionally rev the engine to 4,000 to 5,000 r/min.

The engine is warm when it quickly responds to the throttle.

2. Set the idle to the specified engine speed by adjusting the throttle stop screw. Turn the screw in to increase engine speed, or out to decrease engine speed.

Standard idle speed:  
1,450 ~ 1,550 r/min.

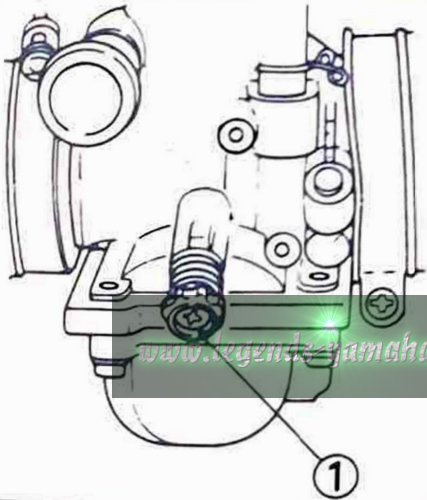

1. Throttle stop screw

U-117

**NOTE:** \_\_\_\_\_

If the specified idle speed cannot be obtained by performing the above adjustment, consult a Yamaha dealer or other qualified mechanic.

---

H-903

## Throttle cable adjustment

U-064

**NOTE:** \_\_\_\_\_

Before adjusting the throttle cable free play, the engine idling speed should be adjusted.

---

The throttle cable should have a specified free play in the turning direction at the grip flange. If the play is incorrect, take the following steps for adjustment.



## Spark plug inspection

The spark plug is an important engine component and is easy to inspect. The condition of the spark plug can indicate something of the condition of the engine.

The ideal color on the white porcelain insulator around the center electrode is a medium to light tan color for a machine that is being ridden normally. Do not attempt to diagnose any problems yourself. Instead, take the machine to a Yamaha dealer or other qualified mechanic. You should periodically remove and inspect the spark plug because heat and deposits will cause the spark plug to slowly break down and erode. If electrode erosion becomes excessive, or if carbon and other deposits are excessive, you should replace the spark plug with a proper type plug.

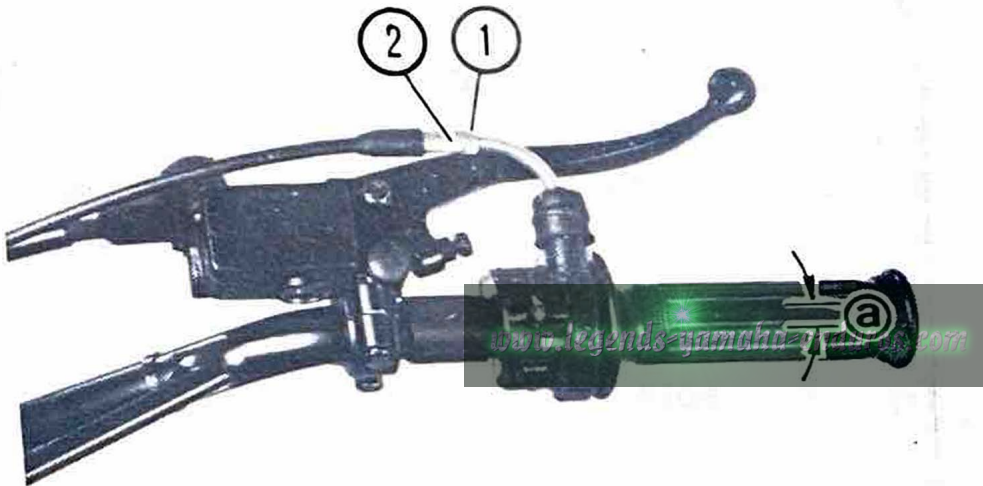

1. Lock nut    2. Adjuster    a. 3–5 mm (0.12~0.20 in)

Free play:

3 – 5 mm (0.12 ~ 0.20 in)

1. Loosen the lock nut.
2. Turn the adjuster in or out until the adjustment is suitable.
3. Tighten the lock nut.

Standard spark plug:  
B8ES (NGK)

Before installing the spark plug, measure the electrode gap with a wire thickness gauge; adjust the gap to specification as necessary.

Spark plug gap:  
0.6 ~ 0.7 mm (0.024 ~ 0.028 in)

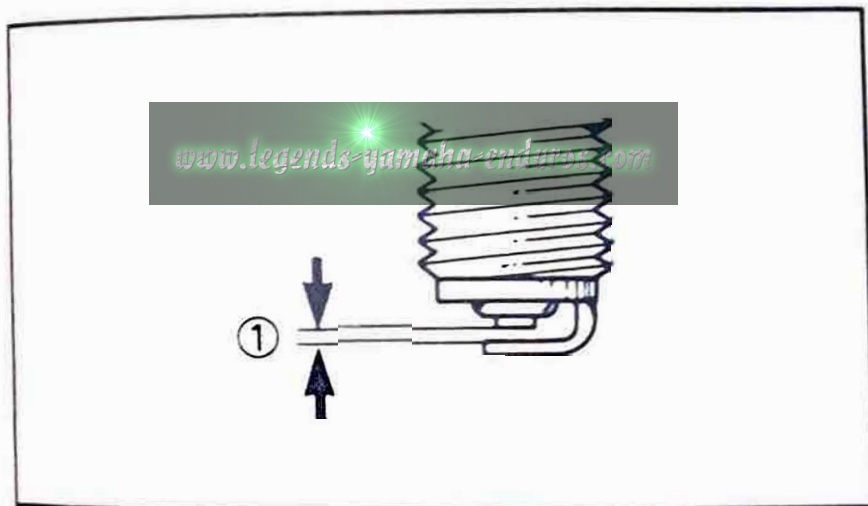

1. Spark plug gap

When installing the plug, always clean the gasket surface and use a new gasket. Wipe off any grime from the threads, and torque the spark plug properly.

Spark plug torque:  
20 Nm (2.0 m•kg, 14 ft•lb)

U-038

**NOTE:** \_\_\_\_\_

If a torque wrench is not available when you are installing a spark plug, a good estimate of the correct torque is 1/4 to 1/2 turns past finger tight. Have the spark plug torqued to the correct value as soon as possible with a torque wrench.

\_\_\_\_\_

## Front brake adjustment

The free play at the end of the front brake lever should be 10 ~ 20 mm (0.4 ~ 0.8 in).

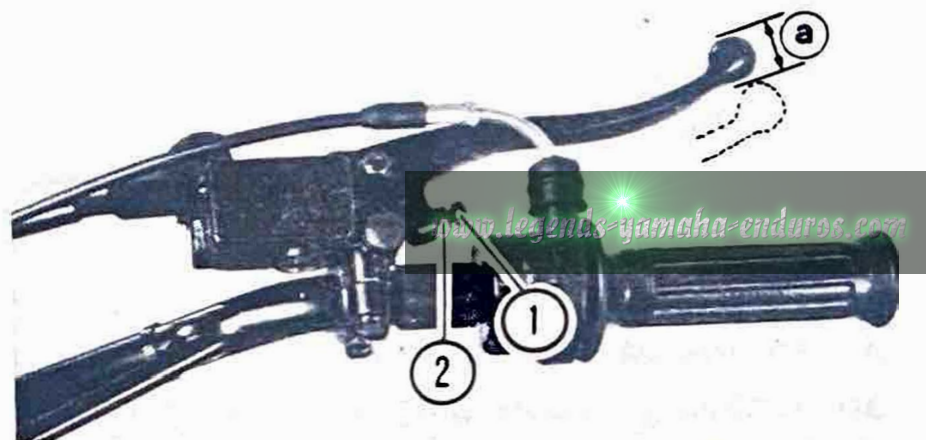

1. Adjuster 2. Lock nut a. 10 ~ 20 mm (0.4 ~ 0.8 in)

1. Loosen the lock nut.
2. Turn the adjuster so that the brake lever movement at the lever end is 10 ~ 20 mm (0.4 ~ 0.8 in) before the adjuster contacts the master cylinder piston.
3. After adjusting, tighten the lock nut.

## **! WARNING**

**Check the brake lever free play. Be sure the brake is working properly.**

## **! WARNING**

**A soft or spongy feeling in the brake lever can indicate the presence of air in the brake system. This air must be removed by bleeding the brake system before the machine is operated. Air in the system will cause greatly diminished braking capability and can result in loss of control and an accident. Have a Yamaha dealer or other qualified mechanic inspect and bleed the system if necessary.**

## Rear brake adjustment

U-642

### **WARNING**

For brake pedal adjustment, be sure to proceed as follows: (It is advisable to have a Yamaha dealer or other qualified mechanic make this adjustment.)

1. Pedal height
  - a. Loosen the adjuster lock nut (for pedal height).
  - b. By turning the adjuster clockwise or counterclockwise, adjust the brake pedal position so that its top end is approx. 20 mm (0.8 in) below the top of the footrest.
  - c. Secure the adjuster lock nut.

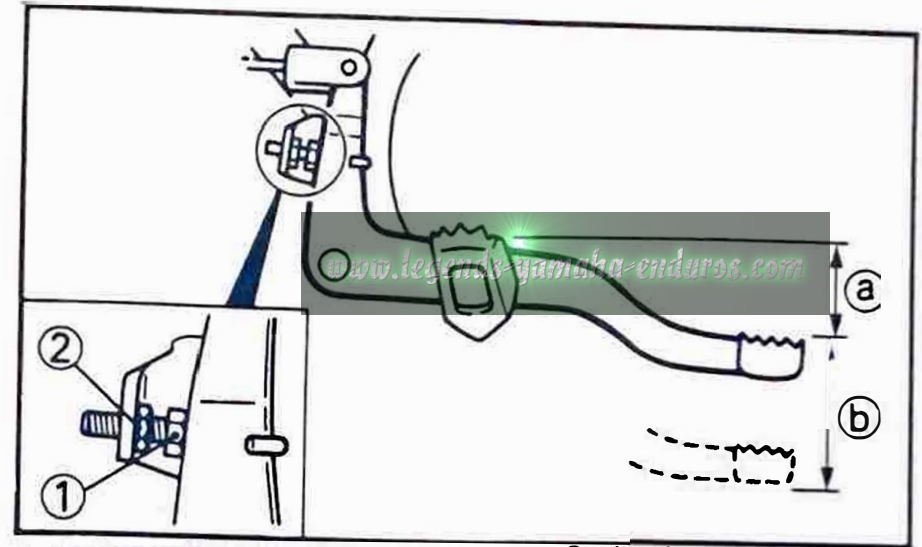

1. Adjuster bolt (for pedal height)
2. Lock nut
- a. Pedal height 20 mm (0.8 in)
- b. Free play 20 ~ 30 mm (0.8 ~ 1.2 in)

U-644

### **WARNING**

After adjusting the pedal height, adjust brake pedal free play.



## 2. Free play

The rear brake should be adjusted to suit the rider's preference; but free play at the brake pedal end must be 20~30 mm (0.8~1.2 in). Turn the adjuster on the brake rod clockwise to reduce play; turn the adjuster counterclockwise to increase play.

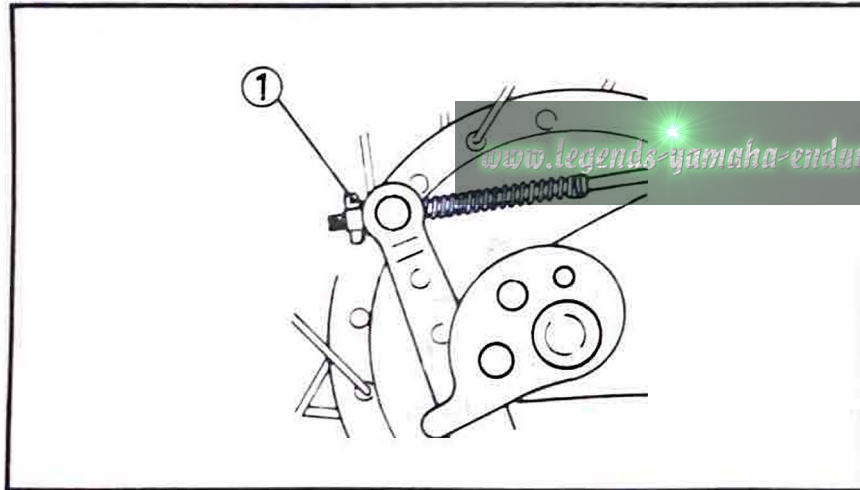

1. Adjuster

## **⚠ WARNING**

**The rear brake pedal adjustment must be checked any time chain is adjusted or rear wheel is removed and then reinstalled.**

H-814

## Checking the front brake pads and rear brake shoes

H-844

### FRONT

Check the brake pads for damage and wear. If the thickness is less than the specified value, have a Yamaha dealer replace the pads.

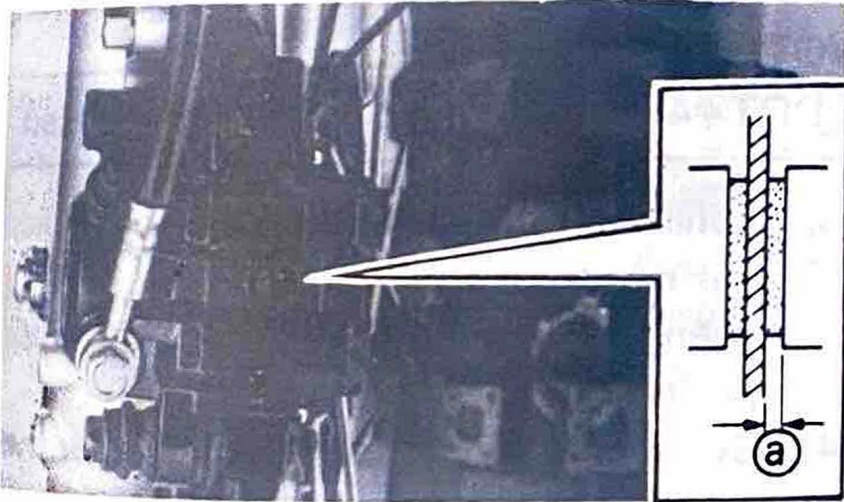

1. Wear limit 0.8 mm (0.031 in)

H-826

### REAR

To check, look at the wear indicator while depressing the brake pedal. If the indicator reaches the wear limit line, ask a Yamaha dealer or other qualified mechanic to replace the shoes.

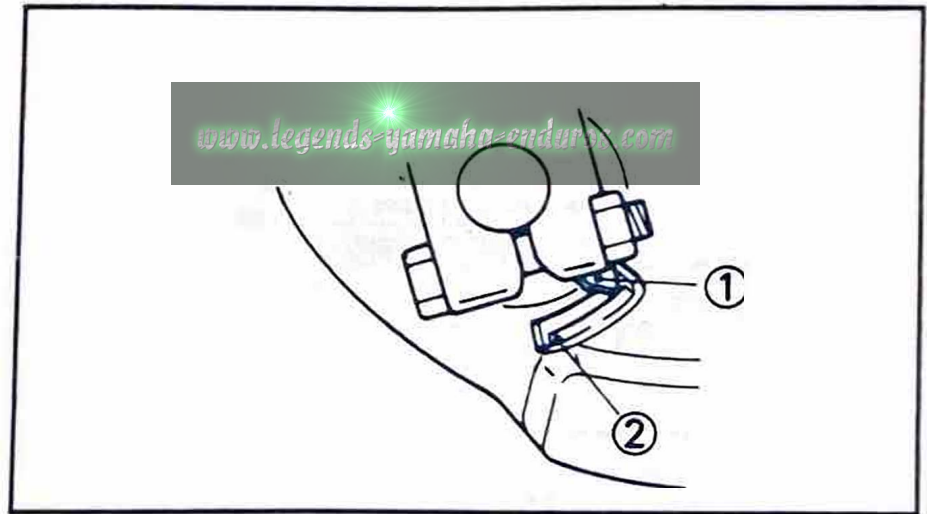

1. Wear indicator 2. Wear limit

## Inspecting the brake fluid level

Insufficient brake fluid may let air enter the brake system, possibly causing the brakes to become ineffective.

Before riding, check the brake fluid level and replenish when necessary; observe these precautions:

1. When checking the fluid level, make sure the master cylinder top is horizontal by turning the handlebars.

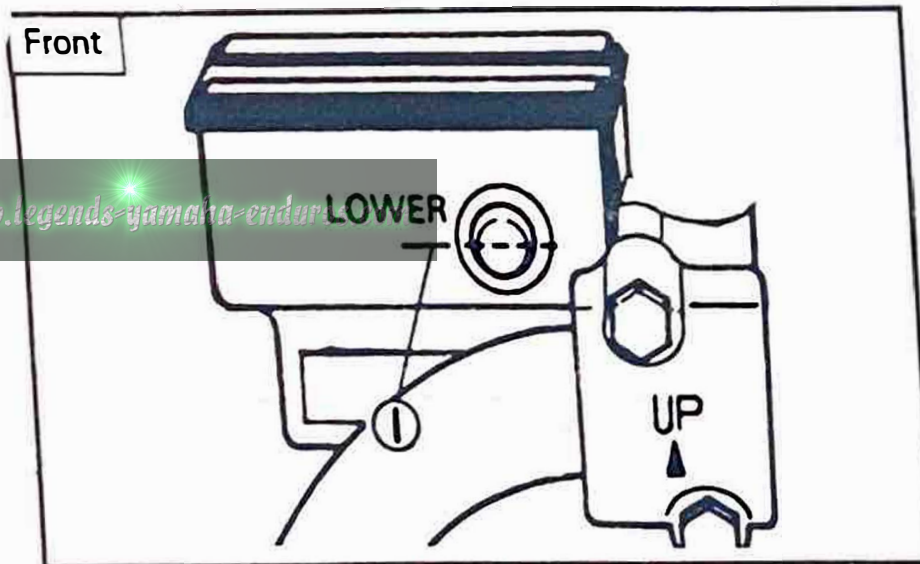

1. Lower level

2. Use only the designated quality brake fluid: otherwise, the rubber seals may deteriorate, causing leakage and poor brake performance.

Recommended brake fluid:

DOT: 4

### NOTE:

If DOT #4 is not available, #3 can be used.

3. Refill with the same type of brake fluid; mixing fluids may result in a harmful chemical reaction and lead to poor performance.
4. Be careful that water does not enter the master cylinder when refilling. Water will significantly lower the boiling point of the fluid and may result in vapor lock.
5. Brake fluid may erode painted surfaces or plastic parts. Always clean up spilled fluid immediately.



6. Have a Yamaha dealer or other qualified mechanic check the cause if the brake fluid level goes down.

H-840

### Brake fluid replacement

1. Complete fluid replacement should be done by a Yamaha dealer or other qualified mechanic.
2. Have a Yamaha dealer or other qualified mechanic replace the following components when indicated in the schedule or when they are damaged or leaking.
  - a. Replace all rubber seals every two years.
  - b. Replace all hoses every four years.

I-001

### Clutch adjustment

This model has two clutch cable length adjusters. The cable length adjusters are used to take up slack from cable stretch and to provide sufficient free play for proper clutch operation.

I-005

### Free play adjustment

The clutch should be adjusted to suit the rider's preference; but, free play at the lever pivot should be 2 ~ 3 mm (0.08 ~ 0.12 in).

Loosen either the handlebar lever adjuster lock nut or the cable length adjuster lock nut. Turn the cable length adjuster either in or out until proper lever free play is achieved.



1. Adjuster
2. Lock nut
- a. 2 ~ 3 mm (0.08 ~ 0.12 in)



## Drive chain slack check

U-048

### NOTE:

Before checking and/or adjusting the chain slack, rotate the rear wheel through several revolutions. Check the chain slack several times to find the point where the chain is the tightest. Check and/or adjust the chain slack where the rear wheel is in this "tight chain" position.

To check the slack, the machine must stand vertically with both wheels on the ground and without a rider. Check the slack at the position shown in the illustration.

The normal vertical deflection is approximately 40 mm (1.6 in). If the deflection exceeds 40 mm (1.6 in) adjust the chain slack.

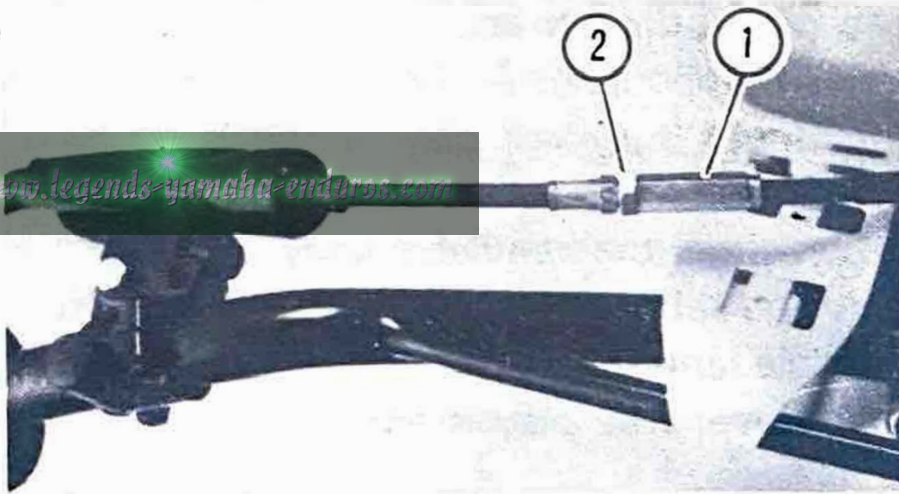

1. Adjuster 2. Lock nut

Clutch lever free play:  
2 – 3 mm (0.08 – 0.12 in)

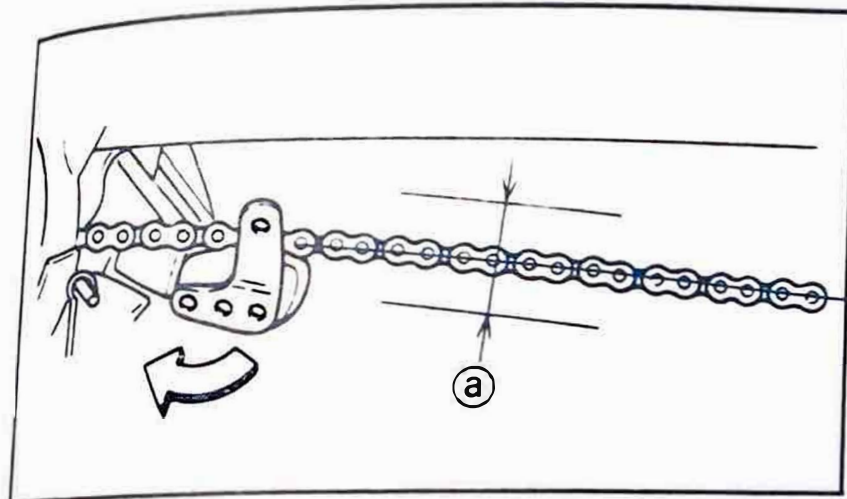

a. 40 mm (1.6 in)

U-049

**NOTE:**

Slack check should be made with the tensioner in the relaxed position (not touching the chain).

I-404

**Drive chain slack adjustment**

1. Loosen the rear brake adjuster.

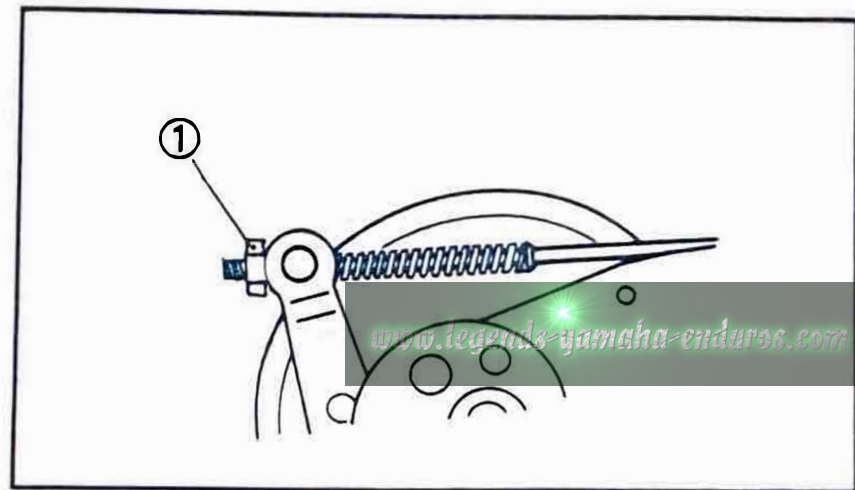

1. Rear brake adjuster

2. Remove the cotter pin from the rear wheel axle nut.
3. Loosen the rear wheel axle nut.
4. Turn chain puller both left and right, until axle is situated in same puller slot position.

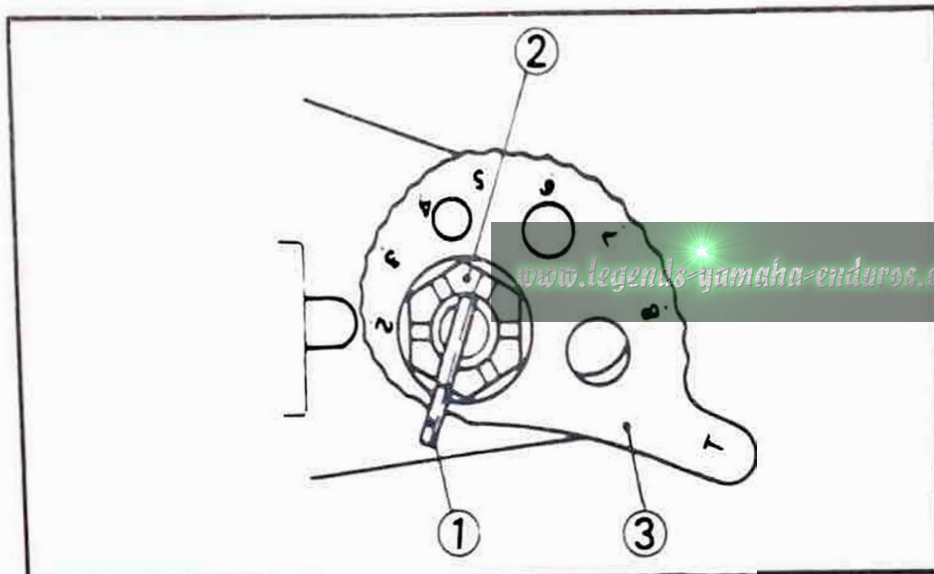

1. Cotter pin      2. Axle nut      3. Chain puller

U-333

**CAUTION:**

**To little chain slack will overload the engine and other vital parts; keep the slack within the specified limits.**

5. After adjusting, be sure to tighten the axle nut.

Axle nut torque:  
85 Nm (8.5 m•kg, 61 ft•lb)

6. Insert new cotter pin into the rear wheel axle nut and bend the end of cotter pin as shown in the illustration. (If the nut notch and cotter pin hole do not match, tighten the nut slightly to align them.)

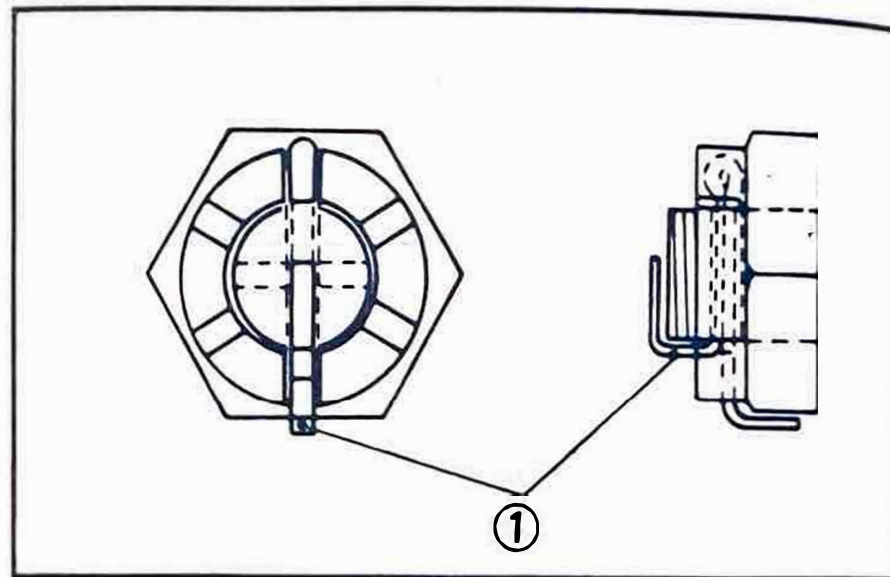

1. Cotter pin

U-647

**! WARNING**

**Always use a new cotter pin on the axle nut.**

7. Adjust the free play in the brake pedal.

### Drive chain lubrication

The chain consists of many parts which work against each other. If the chain is not maintained properly, it will wear out rapidly, therefore, service the chain regularly. This service is especially necessary when riding in dusty conditions.

1. Use Yamaha Chain and Cable Lube or any brands of spray type chain lubricant. First, remove all dirt and mud from the chain with a brush or cloth, then spray a lubricant between both rows of side plates and on all center rollers. This should be performed every ride.
2. To clean the chain, remove the chain from the machine, dip it in solvent, and clean out as much dirt as possible. Take the chain out of the solvent and dry it. Immediately lubricate the chain to prevent rust.

### Cable inspection and lubrication



**Damage to the outer housing of the various cables may cause corrosion and interfere with the movement of the cable. An unsafe condition may result so replace such cables as soon as possible.**

Lubricate the inner cable and the cable end. If they do not operate smoothly, ask a Yamaha dealer or other qualified mechanic to replace them.

Recommended lubricant:  
Yamaha Chain and Cable Lube or  
SAE 10W30 motor oil



I-102

### **Throttle cable and grip lubrication**

The throttle twist grip assembly should be greased at the time that the cable is lubricated, since the grip must be removed to get at the end of the throttle cable. Two screws clamp the throttle housing to the handlebar. Once these two are removed, the end of the cable can be held high to pour in several drops of lubricant. With the throttle grip disassembled, coat the metal surface of the grip assembly with a suitable all-purpose grease.

I-108

### **Autolube pump adjustment**

The Autolube pump is a vital part of the engine and requires very sophisticated adjustment. Adjusting should be left to a Yamaha dealer who has the professional knowledge and experience to do so.

I-302

### **Brake and change pedals**

Lubricate the pivoting parts.

Recommended lubricant:

Yamaha Chain and Cable Lube or  
SAE 10W30 motor oil

I-303

### **Brake and clutch levers**

Lubricate the pivoting parts.

Recommended lubricant:

Yamaha Chain and Cable Lube or  
SAE 10W30 motor oil

I-310

### **Sidestand**

Lubricate the pivoting parts. Check to see that the sidestand moves up and down smoothly.

Recommended lubricant:  
Yamaha Chain and Cable Lube or  
SAE 10W30 motor oil

U-701



If the sidestand movement is not smooth,  
consult a Yamaha dealer or other qualified  
mechanic.

I-313

### Rear suspension

Lubricate the pivoting parts.

Recommended lubricant:  
Lithium soap base grease

## Front fork inspection

I-206



Securely support the machine so there is  
no danger of it falling over.

U-657

1. Visual check  
Check any scratch/damage on the inner  
tube and excessive oil leakage with the  
front fork.
2. Operation check  
Place the machine on a level place.
  - a. Hold the machine on an upright po-  
sition with a rider's hands on the han-  
dlebar and apply the front brake.
  - b. Pump the front fork up and down  
several times.

## Rear shock absorber

U-674



### CAUTION:

---

If any damage or unsmooth movement is found with the front fork, consult a Yamaha dealer or other qualified mechanic.

---

### **WARNING**

This shock absorber contains highly pressurized nitrogen gas. Read and understand the following information before handling the shock absorber. The manufacturer cannot be held responsible for property damage or personal injury that may result from improper handling.

1. Do not tamper with or attempt to open the cylinder assembly.
2. Do not subject shock absorber to an open flame or other high heat source. This may cause the unit to explode due to excessive gas pressure.
3. Do not deform or damage the cylinder in any way. Cylinder damage will result in poor damping performance.

4. Bring your shock absorber to a Yamaha dealer or other qualified mechanic for any service.

### Rear shock absorber adjustment

The spring preload of the rear shock absorber can be adjusted to suit rider's preference, weight, and the course conditions.

1. Remove the both side covers, seat and fuel tank.
2. To increase preload, raise the spring seat.

To decrease preload, lower the spring seat.

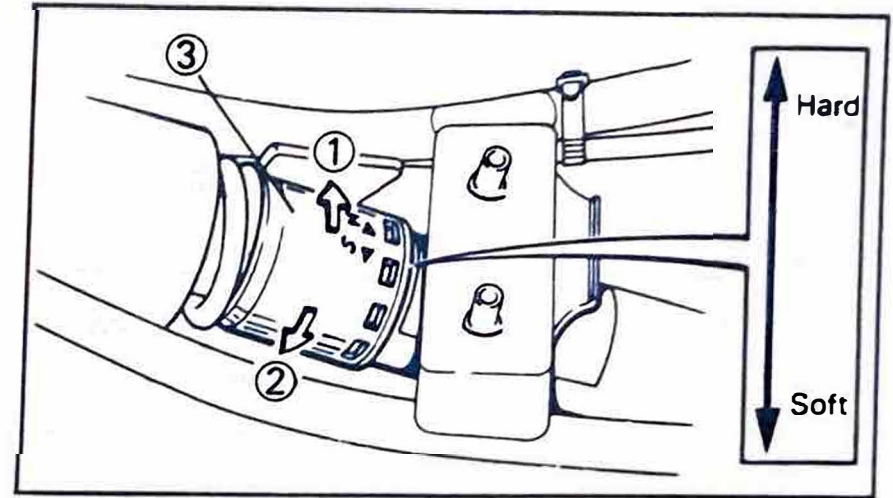

1. Increase spring preload
2. Decrease spring preload
3. Adjuster

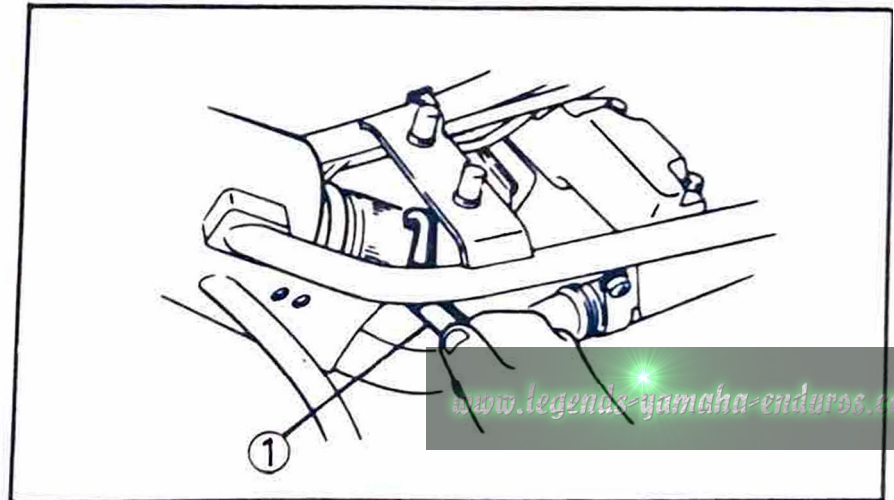

1. Special wrench



	Soft		STD	Hard	
Adjusting position	1	2	3	4	5

U-052

**NOTE:** \_\_\_\_\_

When adjusting, use the special wrench which is included in the owner's tool kit.

---

3. Install the fuel tank, seat and both side covers.

I-600

## Steering inspection

Periodically inspect the condition of the steering. Worn out or loose steering bearings may be dangerous.

Place a block under the engine to raise the front wheel off the ground.

Hold the lower end of the front forks and try to move them forward and backward. If any free play can be felt, ask a Yamaha dealer or other qualified mechanic to inspect and adjust the steering. Inspection is easier if the front wheel is removed.

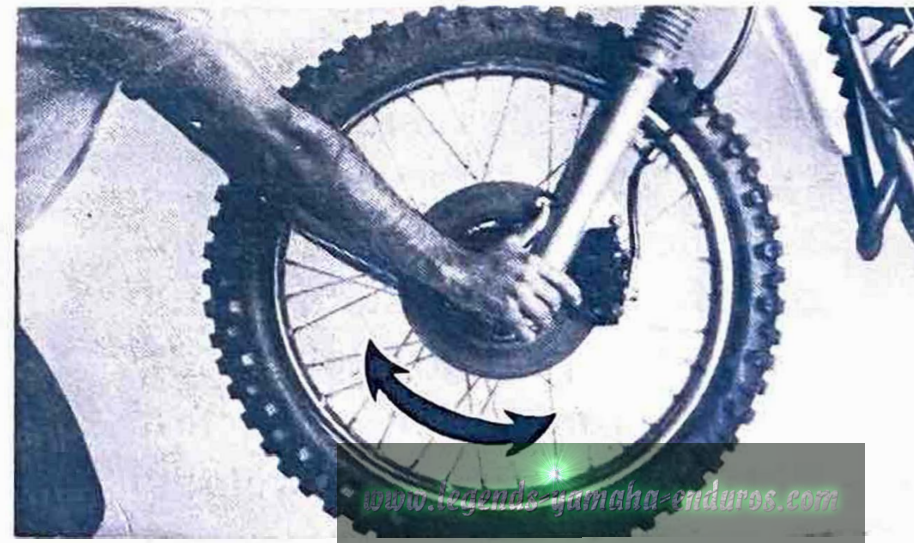

**WARNING**

Securely support the machine so there is no danger of it falling over.

**Wheel bearings**

If the wheel bearings in the front or rear wheel allow play in the wheel hub or if the wheel does not turn smoothly, have a Yamaha dealer or a qualified mechanic inspect the wheel bearings. The wheel bearings should be inspected according to the Periodic Maintenance/Lubrication Schedule.

**Front wheel removal**

1. Elevate the front wheel by placing a suitable stand under the engine.
2. Remove the cotter pin and wheel axle nut.

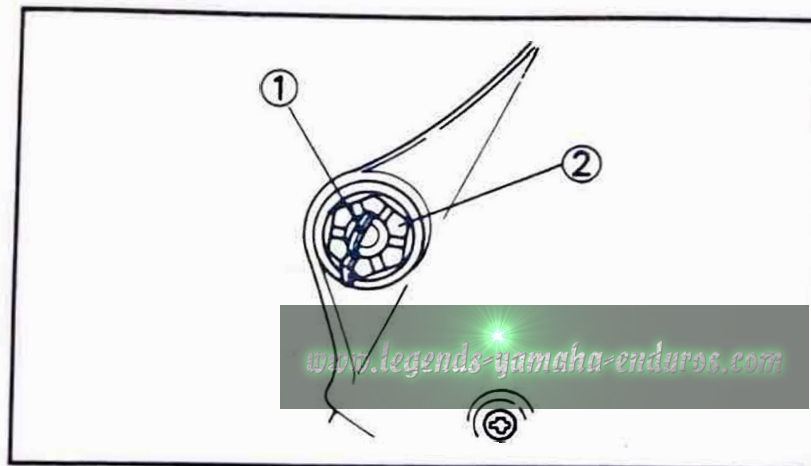

1. Cotter pin

2. Axle nut

3. Remove the axle and the front wheel. Make sure the machine is properly supported.

## Front wheel installation

When installing the front wheel, reverse the removal procedure.

1. Make sure the projecting portion (torque stopper) of the gear housing is positioned correctly.

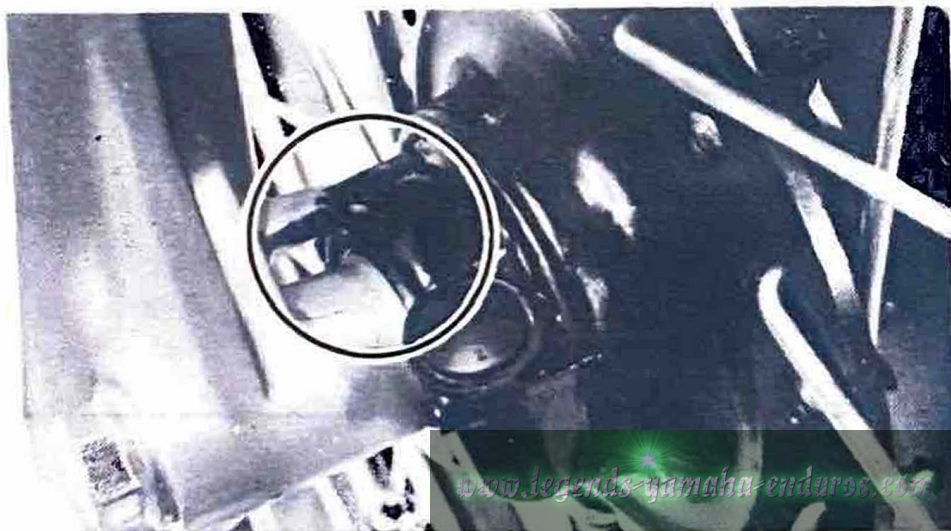

2. Make sure the axle nut is properly torqued, and a new cotter pin is installed.

U-647

### **WARNING**

**Always use a new cotter pin on the axle nut.**

**Axle nut torque:  
85 Nm (8.5 m•kg, 61 ft•lb)**



## Rear wheel removal

**! WARNING**

It is advisable to have a Yamaha dealer or other qualified mechanic service the rear wheel.

- 1 Elevate the rear wheel by placing a suitable stand under the engine.
- 2 Remove the brake adjuster and brake rod from the brake cam lever.

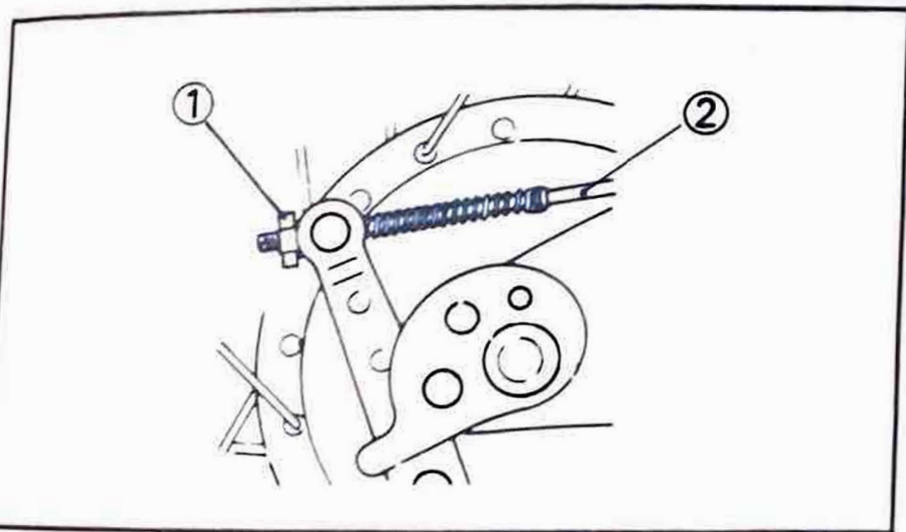

Adjuster

2. Brake rod

3. Remove the cotter pin from the axle nut and remove the axle nut.

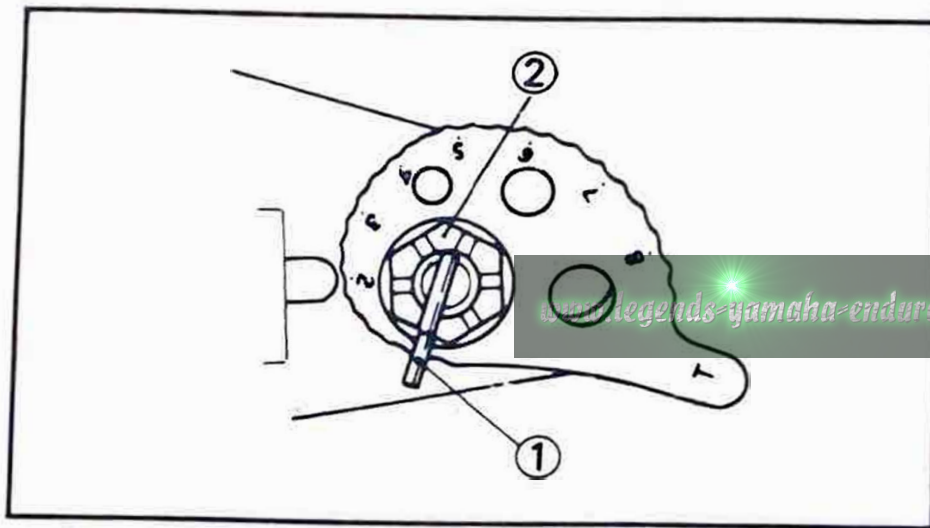

1. Cotter pin    2. Axle nut

4. The rear wheel assembly, the collar, the chain pullers, etc., can be removed from the machine by pulling the wheel axle.



## Rear wheel installation

When installing the rear wheel, reverse the removal procedure. Pay attention to the following points:

1. Be sure the swingarm boss correctly engages the locating slot on the brake shoe plate.

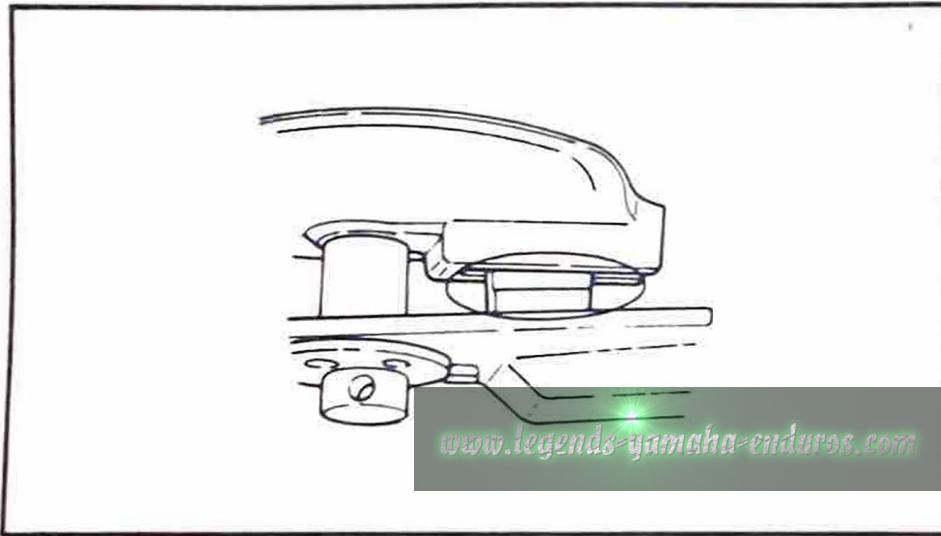

2. Make sure the rear wheel axle is inserted on the right-hand side and that the chain pullers are installed with the punched side outward.
3. Adjust the drive chain.

4. Make sure the axle nut is properly torqued, and a new cotter pin is installed.

U-647

### **! WARNING**

**Always use a new cotter pin on the axle nut.**

**Axle nut torque:  
85 Nm (8.5 m.kg, 61 ft.lb)**

5. Adjust the rear brake. (See page 8-15)

## Troubleshooting

Although Yamaha machines receive a rigid inspection before shipment from the factory, trouble may occur during operation. Any problem in the fuel, compression, or ignition systems can cause poor starting and a loss of power. The troubleshooting chart describes a quick, easy procedure for checking these systems.

If your machine requires any repair, bring it to a Yamaha dealer. The skilled technicians at a Yamaha dealer have the tools, experience, and know-how to properly service your machine. Use only genuine Yamaha parts or parts of equivalent design and quality. Be aware that imitation parts may look like Yamaha parts, but they are often inferiors. Consequently, they have a shorter service life and can lead to expensive repair bills.

# Troubleshooting chart



## **⚠ WARNING**

Never check the fuel system while smoking or in the vicinity of an open flame.

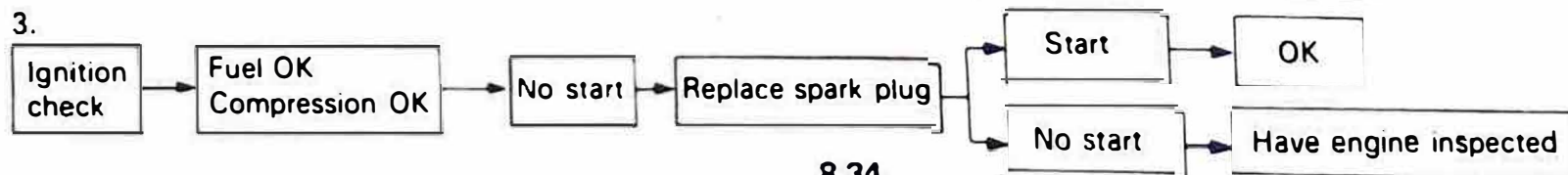
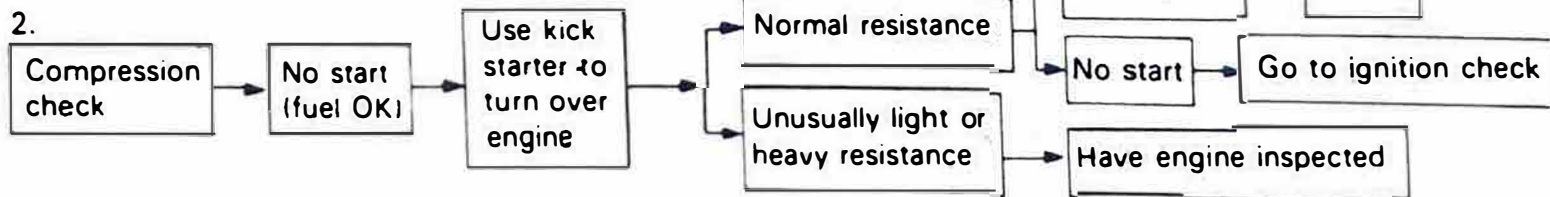
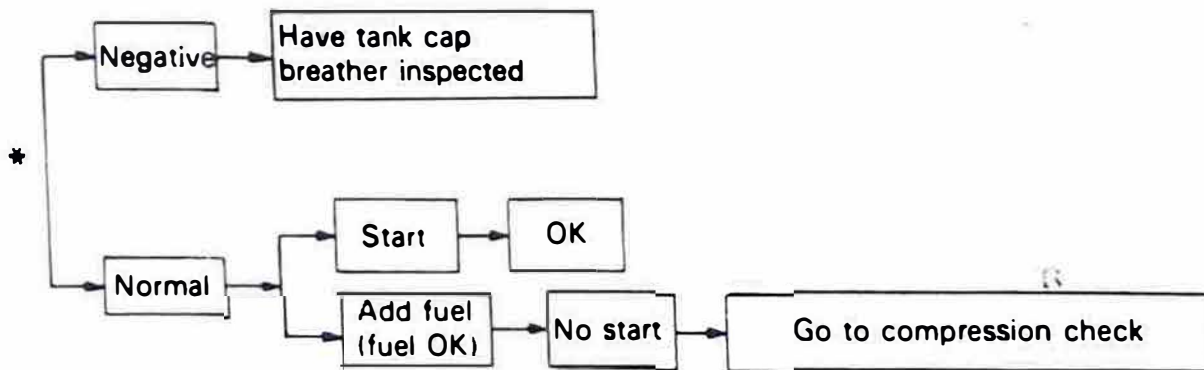
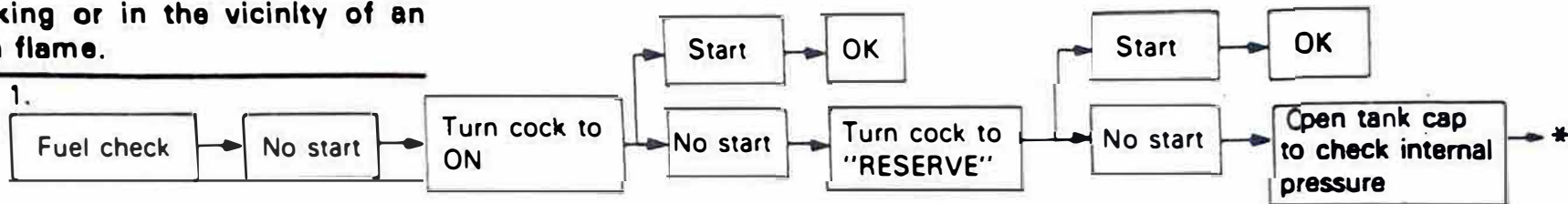

# CLEANING AND STORAGE

K 002

## A. CLEANING

Frequent thorough cleaning of your machine will not only enhance its appearance but will improve its general performance and extend the useful life of many components.

1. Before cleaning the machine:
  - a. Block off the end of exhaust pipe to prevent water entry; a plastic bag and strong rubber band may be used.
  - b. Make sure the spark plug(s) and all filler caps are properly installed.
2. If the engine case is excessively greasy, apply degreaser with a paint brush. Do not apply degreaser to the chain, sprockets, or wheel axles.
3. Rinse the dirt and degreaser off with a garden hose, use only enough pressure to do the job.

## CAUTION:

---

Excessive hose pressure may cause water seepage and contamination of wheel bearings, front forks, brakes and transmission seals. Many expensive repair bills have resulted from improper high pressure detergent applications such as those available in coin-operated car washers.

---

4. Once the majority of the dirt has been hosed off, wash all surfaces with warm water and mild, detergent-type soap. An old tooth brush or bottle brush is handy for hard-to-get-to places.
5. Rinse the machine off immediately with clean water and dry all surfaces with a chamois, clean towel, or soft absorbent cloth.
6. Dry the chain and lubricate it to prevent rust.



7. Clean the seat with a vinyl upholstery cleaner to keep the cover pliable and glossy.
8. Automotive-type wax may be applied to all painted and chrome plated surfaces. Avoid combination cleaner-waxes. Many contain abrasives which may mar the paint or protective finish. When finished, start the engine and let it idle for several minutes.

## **B. STORAGE**

Long term storage (60 days or more) of your machine will require some preventive procedures to guard against deterioration. After thoroughly cleaning the machine, prepare for storage as follows:

1. Drain the fuel tank, fuel lines, and carburetor float bowl(s).
2. Remove empty fuel tank, pour a cup of SAE 10W30 or 20W40 motor oil in tank, shake the tank to coat the inner surfaces thoroughly and drain off the excess oil. Reinstall the tank.
3. Remove the spark plug, pour about one tablespoon of SAE 10W30 or 20W40 motor oil in the spark plug hole and reinstall the spark plug. Kick the engine over several times (with ignition off) to coat the cylinder walls with oil.

4. Remove the drive chain. Clean it thoroughly with solvent and lubricate it. Reinstall the chain or store it in a plastic bag (tied to frame for safe-keeping).
5. Lubricate all control cables.
6. Block up the frame to raise both wheels off the ground.
7. Tie a plastic bag over the exhaust pipe outlet to prevent moisture from entering.
8. If storing in a humid or salt-air atmosphere, coat all exposed metal surfaces with a light film of oil. Do not apply oil to any rubber parts or the seat cover.

U-058

**NOTE:** \_\_\_\_\_

Make any necessary repairs before storing the machine.

---

[www.legends-yamaha-enduros.com](http://www.legends-yamaha-enduros.com)

# SPECIFICATIONS

Model	RT180A
<b>Dimension:</b> Overall length Overall width Overall height Seat height Wheel base Minimum ground clearance	2,050 mm (80.7 in) 860 mm (33.9 in) 1,175 mm (46.3 in) 860 mm (33.9 in) 1,345 mm (53.0 in) 290 mm (11.4 in)
<b>Basic weight:</b> With oil and full fuel tank	112 kg (247 lb)
<b>Minimum turning radius:</b>	2,200 mm (86.6 in)
<b>Engine:</b> Type Model Cylinder arrangement Displacement Bore × Stroke Compression ratio	Air cooled 2-stroke, gasoline 3VC1 Single cylinder, Forward inclined 176 cm <sup>3</sup> 64,5 x 54 mm (2.54 x 2.12 in) 6.5 : 1

Model	RT180A
Starting system Lubrication system	Kick starter Separate lubrication (Yamaha Autolube)
Engine oil (2-cycle): Type Capacity	Air cooled 2-stroke engine oil 0.75 L (0.66 Imp qt, 0.79 US qt)
Transmission oil: Type Capacity Periodic oil change Total amount	SAE 10W30 type SE motor oil  0.55 L (0.48 Imp qt, 0.58 US qt) 0.6 L (0.53 Imp qt, 0.63 US qt)
Air filter:	Wet type element
Fuel: Type Tank capacity Reserve amount	UNLEADED FUEL RECOMMENDED 13 L (2.86 Imp gal, 3.43 US gal) 1.1 L (0.24 Imp gal, 0.29 US gal)
Carburetor: Type/manufacturer	VM24SS/MIKUNI



Model	RT180A
<b>Spark plug:</b> Type/manufacturer Gap	<b>B8ES/NGK</b> 0.6 ~ 0.7 mm (0.024 ~ 0.028 in)
<b>Clutch type:</b>	<b>Wet, multi-disc</b>
<b>Transmission:</b> Primary reduction system Primary reduction ratio Secondary reduction system Secondary reduction ratio Transmission type Operation	<b>Helical gear</b> <b>71/22 (3.227)</b> <b>Chain drive</b> <b>51/14 (3.643)</b> <b>Constant mesh 6-speed</b> <b>Left foot operation</b>
<b>Gear ratio</b> 1st 2nd 3rd 4th 5th 6th	<b>35/11 (3.182)</b> <b>29/15 (1.933)</b> <b>26/19 (1.368)</b> <b>24/22 (1.091)</b> <b>22/23 (0.957)</b> <b>21/25 (0.840)</b>

Model	RT180A
<b>Chassis:</b> Frame type Caster angle Trail	Semi double cradle 28.5° 119 mm (4.7 in)
<b>Tire:</b> Type Size — Front Rear	With tube 80/100-21 100/100-18
<b>Brake:</b> Front brake type Operation Rear brake type Operation	Single disc brake Right hand operation Drum brake Right foot operation
<b>Suspension:</b> Front Rear	Telescopic fork Swing arm (Monocross suspension)
<b>Shock Absorber:</b> Front Rear	Coil spring, Oil damper Gas, Coil spring, Oil damper

Model	RT180A
<b>Wheel travel:</b> Front Rear	200 mm (7.9 in) 150 mm (5.9 in)
<b>Electrical:</b> Ignition system Generator system	CDI magneto Flywheel magneto
<b>Indicator light wattage/quantity:</b> "Oil level"	3.4W x 1

# MOTORCYCLE NOISE REGULATION

## TAMPERING WITH NOISE CONTROL SYSTEM PROHIBITED:

Federal law prohibits the following acts or the causing thereof: (1) The removal or rendering inoperative by any person other than for purposes of maintenance, repair, or replacement of any device or element of design incorporated into any new vehicle for the purpose of noise control prior to its sale or delivery to the ultimate purchaser or while it is in use or (2) the use of the vehicle after such device or element of design has been removed or rendered inoperative by any person.

**"AMONG THOSE ACTS PRESUMED TO CONSTITUTE TAMPERING ARE THE ACTS LISTED BELOW"**

These acts include tampering with the following systems; i.e., modification, removal, etc.

Exhaust system	Muffler Exhaust pipe Silencer
Intake system	Air cleaner case Air cleaner element Intake duct



# MAINTENANCE RECORD

Make sure whoever performs the maintenance completes this record.

MAINTENANCE INTERVAL	DATE OF SERVICE	MILEAGE	SERVICING DEALER NAME AND ADDRESS	REMARKS

# WIRING DIAGRAM RT180A

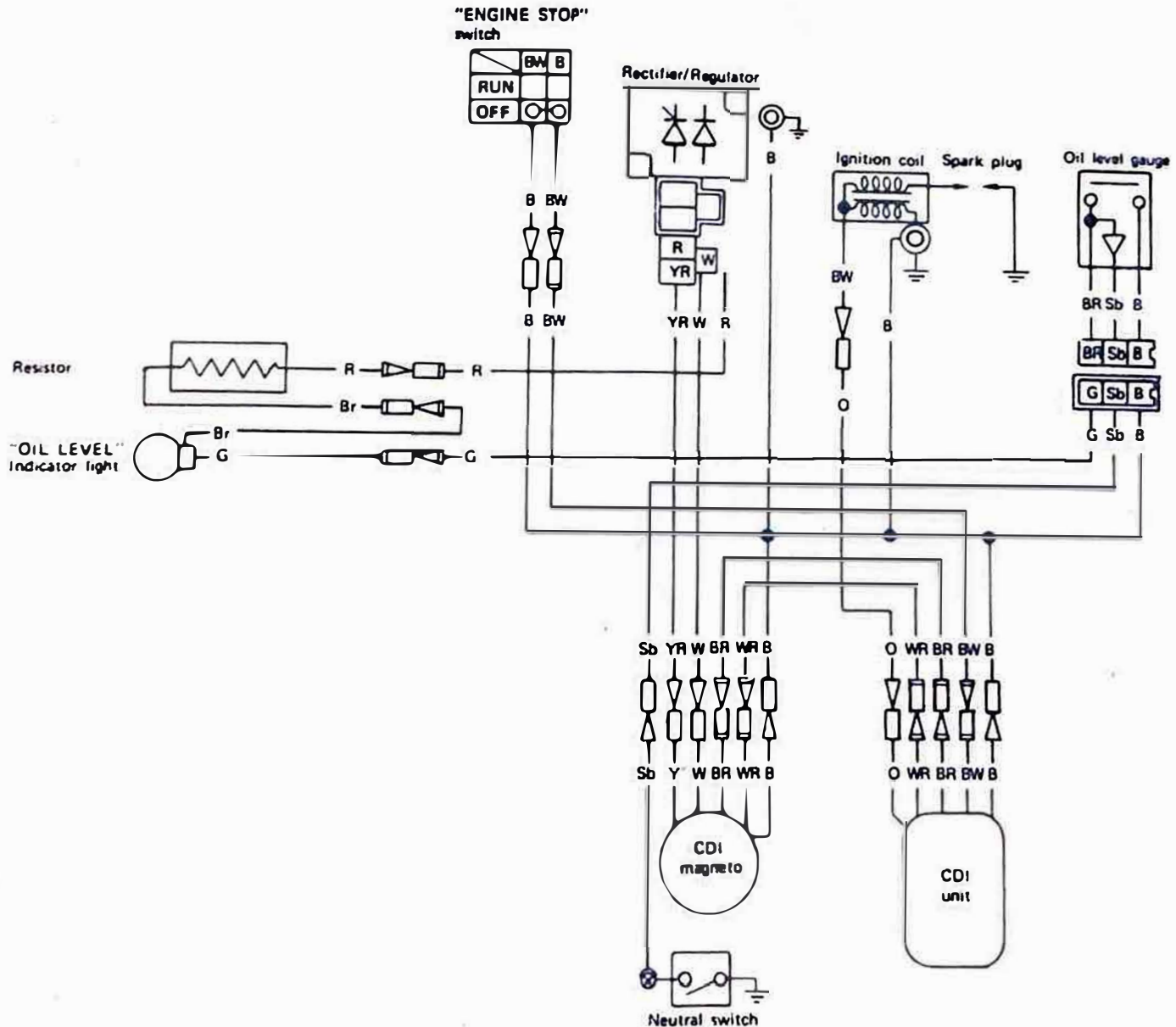

## COLOR CODE

- B ..... Black
- Br ..... Brown
- G ..... Green
- Y ..... Yellow
- Sb ..... Sky blue
- O ..... Orange
- W ..... White
- R ..... Red
- B/W .... Black/White
- Y/R .... Yellow/Red
- B/R .... Black/Red
- B/W .... Black/White
- W/R .... White/Red

[www.legends-yamaha-enduros.com](http://www.legends-yamaha-enduros.com)



**YAMAHA**

PRODUCED BY YAMAHA MOTOR DA AMAZONIA LTDA.

PRINTED IN BRAZIL  
10.89 5,000 CS  
(E)