

YAMAHA

SINGLE ENDURO

RIDER'S MANUAL

90 HT1

www.legends-yamaha-enduros.com

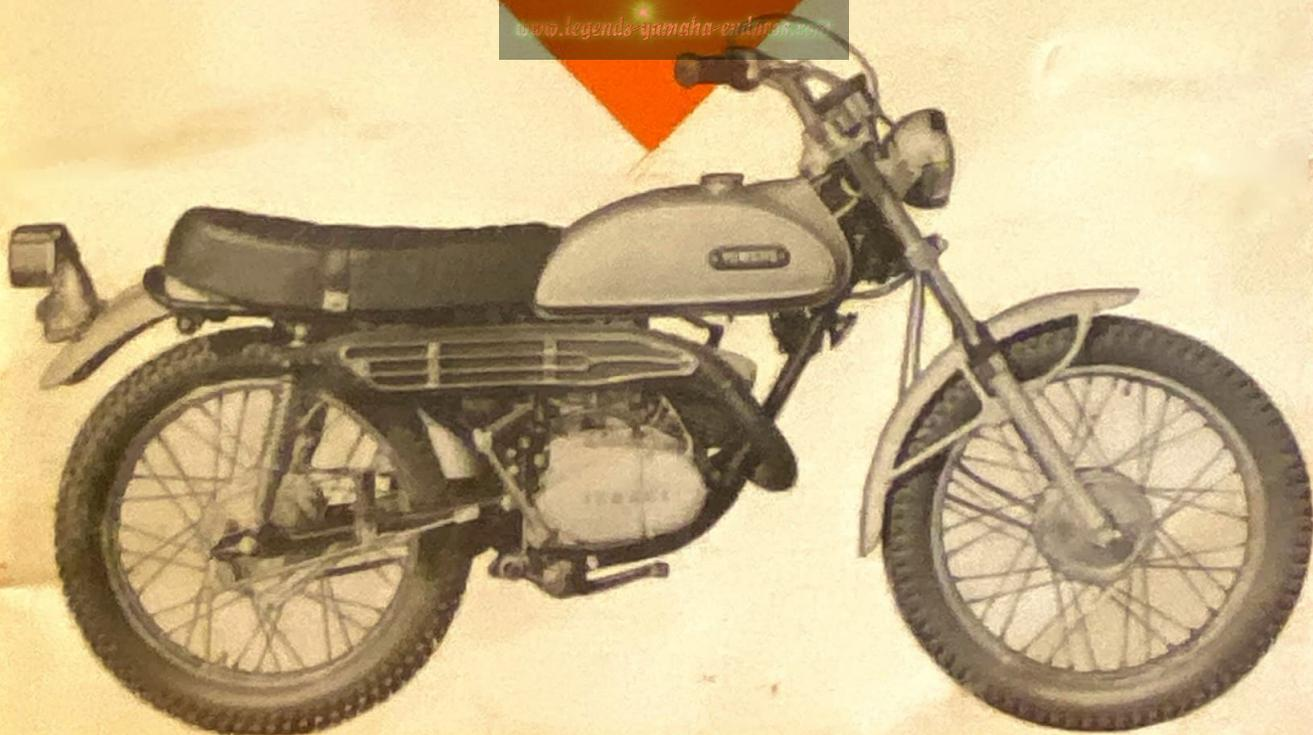

YAMAHA MOTOR CO., LTD.

(アメリカ・カナダ製)

FOREWORD

We are highly gratified that you have selected the Yamaha Single ENDURO 90 HTI — a wise choice that promises you many delightful years of motorecycling.

This 90 ENDURO is designed to a truly street scrambler, and perfect for riding over fields and mountain trails as well as for high-way riding. Most important, it can be quickly converted into a motocrosser by simply removing accessory parts. Your joy with this charming Yamaha ENDURO will be endless.

This manual is planned to help you realize the full potential of your Yamaha ENDURO. Please read it carefully before riding you Yamaha, because it is packed with the important technical information required for your daily riding.

Wherever you go fields, hills or river sides, the Yamaha ENDURO gives you more of pleasure.



CONTENTS

(1) Features and Specifications	3
1. Features	3
2. Specifications	4
(2) Yamaha Autolube	7
(3) Nomenclature	9
(4) Operating Instructions	12
1. Gasoline and Oil	12
2. Main Parts	13
3. Before riding	16
4. How to drive	17
5. Operational Notes	21
(5) Inspection and Service	22
1. Periodical service at Yamaha dealer	22
2. Inspection by the user himself	23
3. Periodical check by use of service tools	24

www.legends-yamaha-enduros.com

(1) Features and Specifications

1. Features

(1) Robust single engine with 5-port design

In order to increase the scavenging efficiency, the Yamaha ENDURO employs the Autolube, piston valve engine with a 5-port cast iron cylinder, assuring steady engine performance throughout the entire speed range from low to high.

(2) 5-speed close-ratio transmission

The Yamaha ENDURO guarantees stable engine performance from low speed off-the-road riding to high speed road work, with the close ratio 5-speed transmission.

(3) Efficient primary kick starter

The primary kick starter enable the engine to start both in gear or in neutral. This is the most convenient design for the motocrosser.

(4) Easy riding position and superb maneuverability

The light-weight sturdy frame combined with the durable component parts are ideal for ideal for off-the-road riding. Agile, comfortable and easy riding position, the Yamaha ENDURO displays superb maneuverability and handling over rough terrain.

(5) Competition designed front forks and rear shocks

The Yamaha ENDURO has telescopic front forks with internal coil springs such as used for competition racers. The front forks provide excellent handling qualities over the roughest terrain with longer stroke and superb damping capacity. The rear shocks have 3-way adjustable springs with a long stroke. This insures stability even under the roughest condition.

2. Specifications

Model:	Yamaha ENDURO 90 HT1
Dimensions:	
Overall length	73.8 in. (1,875 mm)
Overall width	35.4 in. (900 mm)
Overall height	40.7 in. (1,035 mm)
Wheelbase	48.0 in. (1,220 mm)
Ground clearance	8.9 in. (225 mm)
Weight (dry)	187 lbs (85 kg)
Performance	
Max. speed	55 m/h (95 km/h)
Climbing ability	25°
Fuel consumption (on flat paved roads)	164.5 mpg (at 25 mph)
Min. turning radius	68.9 in. (1,750 mm)
Braking distance	23.0 ft/(22) mph 7.0 m (35 km/h)
0-400 m acceleration	21.0 sec.
Engine	
Model	Yamaha HT1
Type	2-cycle, gasoline, 5-port
Lubrication system	Yamaha Autolube (separate lubrication system)
No. of cylinder and arrangement	Single, inclined forward
Bore and stroke	1.969×1.795 in. (50×45.6 mm)
Compression ratio	6.8 : 1
Max. output	8.5 hp/7,000 rpm 8.5 P.S./7,000 rpm
Max. torque	6.51 ft.lb/6,500 rpm 0.9 kg-m/6,500 rpm
Starting system	Primary kick
Ignition system	Magneto ignition

Carburetor:	VM20SC
Air cleaner:	Wet, multi-plane
Power transmission system:	
Transmission	
Type	Constant meshing, 5-speed
Gear ratio 1st	35 / 11 = 3.182
Gear ratio 2nd	30 / 15 = 2.000
Gear ratio 3rd	26 / 19 = 1.368
Gear ratio 4th	23 / 23 = 1.000
Gear ratio 5th	20 / 25 = 0.800
Secondary reduction system	Chain
Secondary reduction gear ratio	49 / 14 = 3.500
Chassis:	
Frame type	Pipe, double cradle
Suspension (front)	Telescopic
Suspension (rear)	Swing arm
Suspension (front)	Coil spring oil damper
Suspension (rear)	Coil spring oil damper
Steering:	
Caster	60.5°
Trail	4.3in
Braking:	
Brake system	Internal expansion
Steering system (front)	Right hand operated (wire)
Steering system (rear)	Right foot operated (rod)
Tire size (front)	2.75-18-4PR (Trial universal)
Tire size (rear)	3.00-18-4PR (Trial universal)

Fuel tank capacity	1.7 gal (6.5ℓ)
Oil tank capacity	1.3 qt. (1.2ℓ)
Generator	
Maker	Hitachi Ltd.
Model	F130-04
Rectification:	Silicon (single-phase, half-wave)
Spark plug:	NGK B-8HC
Battery:	
Model	6N2-2A-3
Capacity	6V 2AH
Lights	
Head lamp	6V, 25W / 25W
Tail/stop lamp	6V, 5.3W / 17W
Meter lamp	6V, 3W
High beam	6V, 1.5W

(2) Yamaha Autolube

What is Yamaha Autolube?

Conventional two-stroke engines are lubricated by oil premixed in gasoline, but Yamaha Autolube furnishes an automatic lubrication system. That is, the oil in a separate oil tank automatically regulated by the oil pump and fed to the engine according to engine speed and load. It is Yamaha's unique separate type lubrication system.

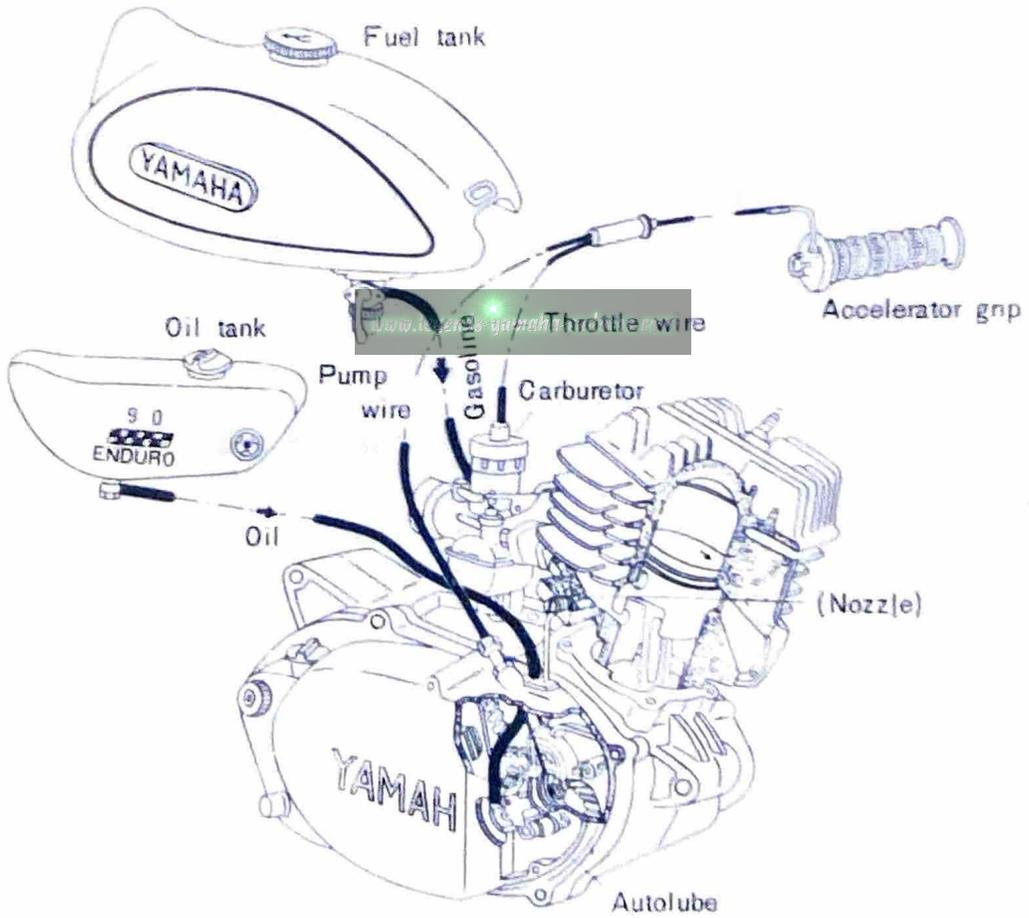

Operation of Yamaha Autolube

The Yamaha Autolube is a small-sized and precision-machined oil pump developed by Yamaha engineering staff. It is driven by the engine through reduction gears, and interlocked with the throttle valve (accelerator grip).

Lubrication oil is properly fed from this Autolube pump according to the engine speed and throttle opening (load); that is, an optimum amount of oil is supplied according to driving conditions.

Features of Yamaha Autolube

The Yamaha Autolube has successfully eliminated various problems stemming from the conventional pre-mixed oil lubrication system, thereby promoting the advantages of two-stroke engines.

1. The Autolube feeds an optimum amount of lubricating oil to the engine under any operating condition.

- Less oil consumption-1/3 of the conventional pre-mixed oil lubrication.
- Less carbon accumulation, [yamaha-enduros.com](https://www.yamaha-enduros.com)
- Less exhaust smoke.

2. The Autolube improves the reliability of lubrication.

- Constant feed of new fresh oil.
- More effective lubrication because of larger size of oil droplets.
- Simplification of oil supply, requiring no special care about oil/fuel mixing ratio.

3. Easy fuel supply

- Fuel tank should be filled with pure gasoline, which is available anywhere.
- No troublesome for mixing oil with gasoline.

* It is advisable that the Yamaha Autolube oil be used to guarantee the high performance and durability of the engine.

(3) Main Parts

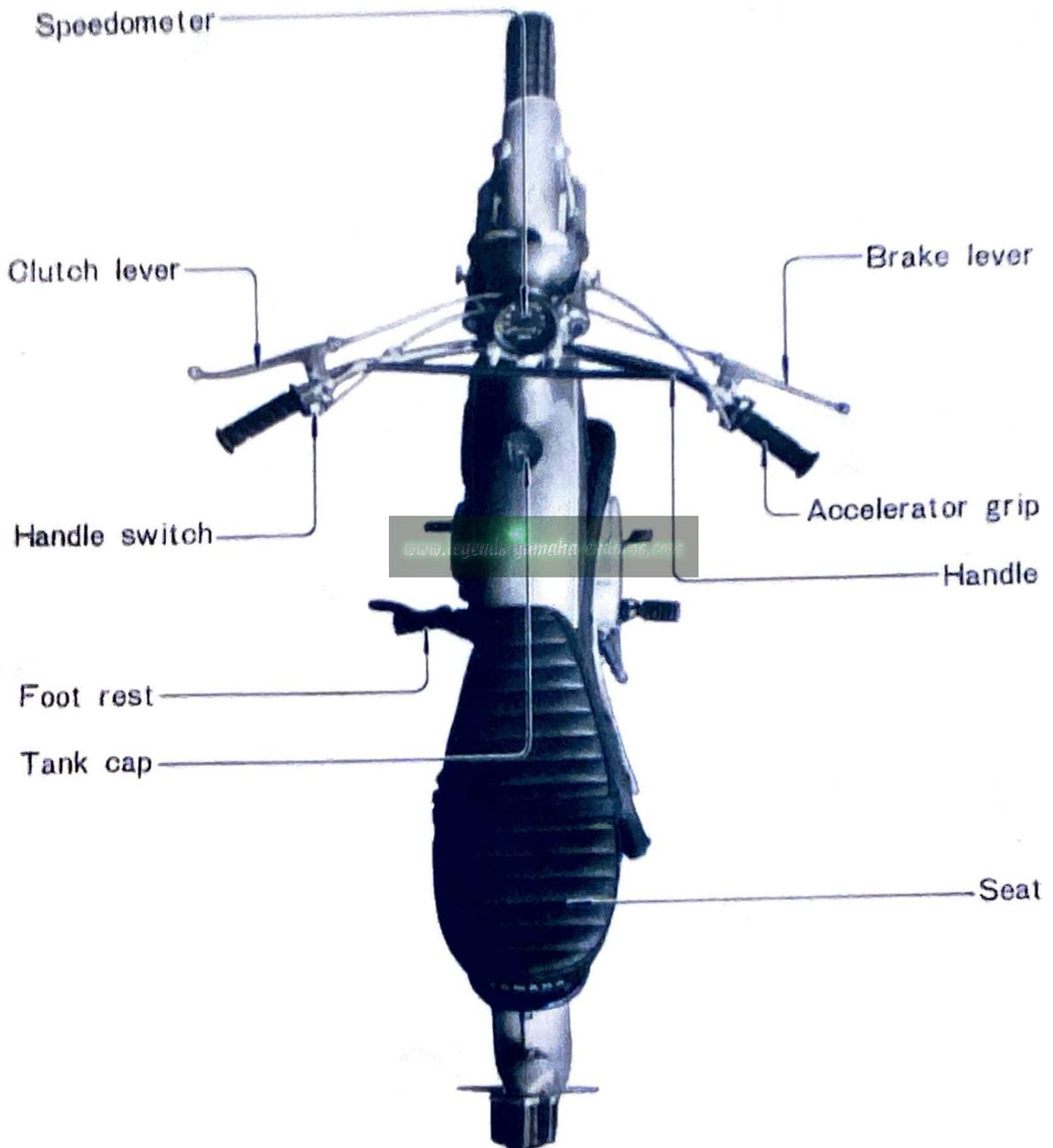

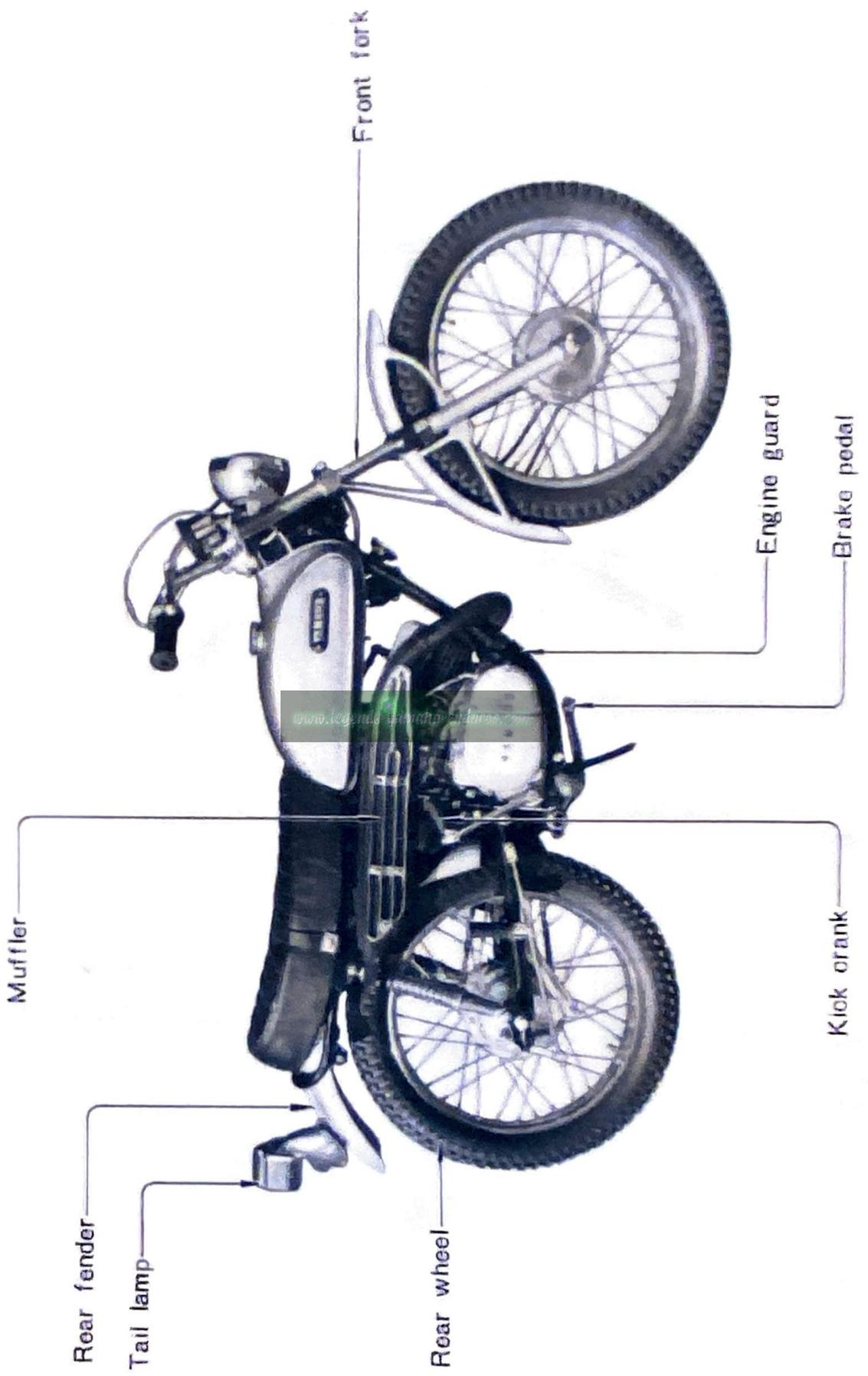

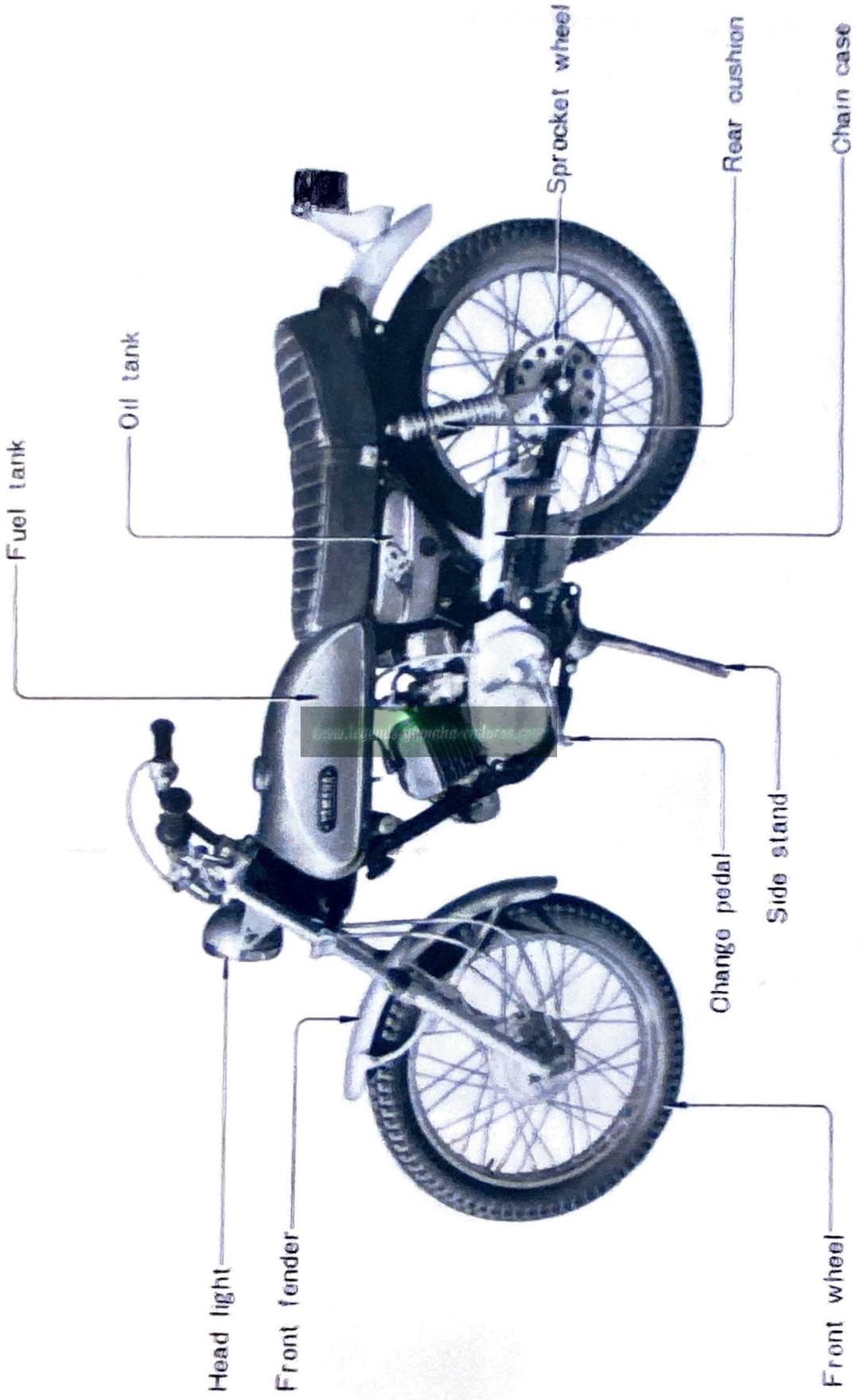

(4) Operating Instructions

1. Gasoline and Oil

Equipped with the Autolube pump, the Yamaha ENDURO uses pure gasoline as fuel.

- The minimum octane of gasoline is required to be 85. The fuel tank capacity is 1.7 gallons.

The oil tank is located under the lefthand side of the rider's seat.

To fill the tank, the seat must be opened.

- The Autolube oil should be used. The oil tank capacity is 1.3 quarts.

* The Yamaha Autolube oil, refined specially for this unique lubricating system, excels in oiliness and purity, particularly in liquidity at low temperature.

The performance of the Autolube depends on the quality of oil. Be sure to use the Yamaha Autolube oil to keep the engine in top condition. It also guarantees longer engine life.



2. Use of the Main Parts

(1) Main Switch

The main switch is designed for two stages, day driving and night driving, plus OFF position.



Key Positions (The circle indicates ON.)

	OFF	I	II	
Starting engine	×	○	○	Kick the kick crank to start.
Horn	×	○	○	Depress the horn button
Head lamp	×	×	○	The engine is running.
Tail lamp	×	×	○	The engine is running.
Stop lamp	×	○	○	When the brake pedal is depressed.
Meter lamp	×	×	○	The engine is running.
Neutral lamp	×	○	○	When gears are shifted to neutral

(2) Fuel Cock

Turning the cock lever downward makes the fuel cock open. To close the cock, turn the lever toward the rear. Turning the lever toward the front allows the reserved fuel to flow to the carburetor. If you should run out of fuel on the road, turn the lever to the spare position. With just over a quart of fuel (about 0.53 gal), you can drive nearly 44 m — enough to get you to the nearest gas station. When parking or storing your machine, be sure to set the lever in the closed position.

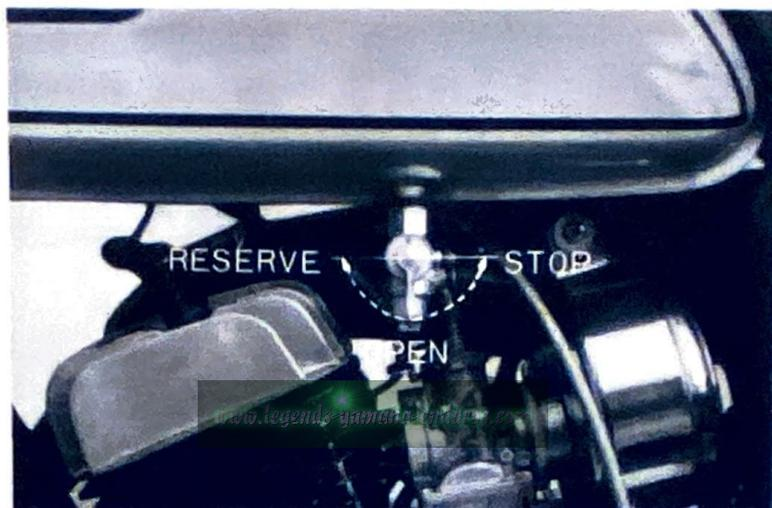

(3) Handlebar Switch

- a. To sound the horn, depress the horn button.
- b. To lower the headlight beam, push the switch toward you. To raise the beam, push the switch forward.

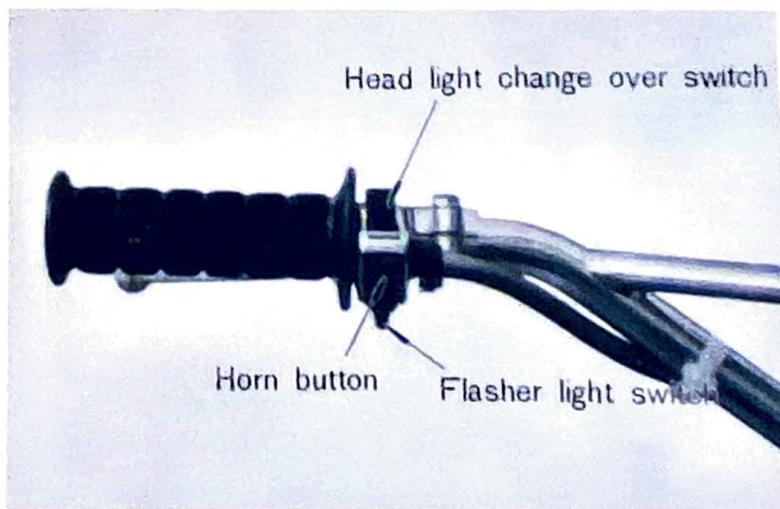

(4) Rear Cushion Adjustment

The rear cushion is designed to be adjustable at three positions. Adjust the cushion properly depending on your load, speed and road conditions.

- Insert the screwdriver (service tool) into the adjusting hole, and turn the notched collar to change the spring rate.

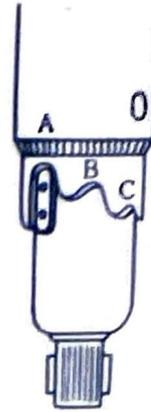
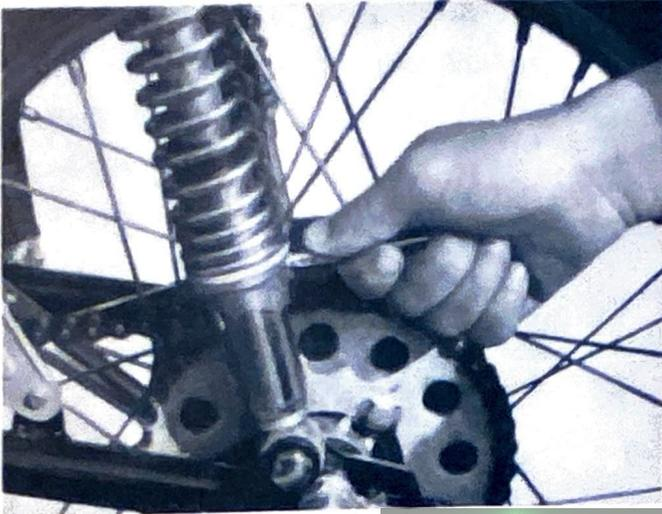

- A Standard
- B Intermediate
- C Stiff

www.legends-yamaha-enduros.com

3. Before Riding

Before you start for a ride you should check several points for safety.

(1) Do you have enough fuel?

Is the fuel tank filled enough for your driving plan? Your Yamaha Autolube engine requires pure gasoline for the tank. Tank capacity is 1.7 gallons.

(2) Do you have enough oil?

Check for the oil level through the glass port. If you plan to go on a long distance trip, open the oil tank cap and make sure that the tank is full. If the oil level is below the glass port, add the Autolube oil. Tank capacity is 1.3 quarts.



(3) Are your tire pressures correct?

Incorrect tire pressures affect the comfort and handling of your machine, and shorten the tire life.

Correct tire pressure

Front wheel 22 lbs/in² (1.5 kg/cm²)

Rear wheel 29 lbs/in² (2.0 kg/cm²)

If tire pressures have to be reduced for off-the-road riding or for other reasons, be sure to use bead stoppers to prevent the tires from slipping around the rims.

(4) **Do both brakes work?**

Check both brakes by pulling in the righthand lever and depressing the brake pedal. Also check the stop light.

(5) **Are the lights and horn working in order?**

Check the horn, headlight, tail lamp, stop lamp, and meter lamp.

4. How to Ride

(1) Starting

The Yamaha ENDURO is equipped with a starter that gives a richer mixture for easier starting even at a low temperature.

Before Starting:

- Turn the fuel cock lever to the "open" position.
- Insert the ignition key and turn it to "I".
- Make sure that the neutral lamp is on.

*The Yamaha ENDURO employs the primary kick system, and therefore, the engine can be started, irrespective of the gear position, provided that the clutch is off.

Starting in Cold Weather:

Any engine is difficult to start in cold or freezing weather.

The Yamaha ENDURO, however, can easily be started by using the starter lever, which provides a richer mixture.

- Depress the starter lever.
- Kick the kick pedal while keeping the accelerator grip.

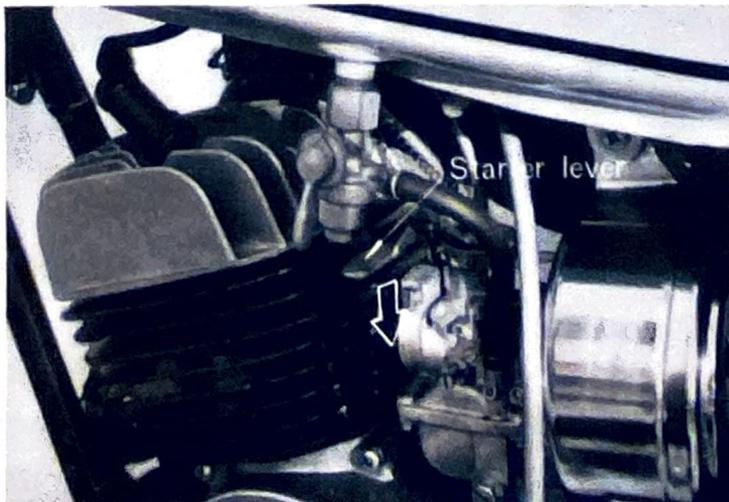

Starting When your Engine is Warm:

- Do not use the starter lever.
- Slightly open the accelerator grip and kick the pedal.

Warming Up:

After the engine has started, keep the engine running for a few minutes. If the starter lever has been used for starting, pull out the starter lever and slowly turn out the accelerator grip until the engine speed picks up smoothly.

* Correct engine warming up is the key point to keep your machine always in top condition. It is as important as periodical inspection.

(2) Shifting Gears

The Yamaha ENDURO has a 5-speed transmission with a rocker-type change pedal. The transmission allows you to control the amount of power and machine speed by changing the combination of gears for starting, acceleration, climbing hills, etc.

The neutral position is located between low and 2nd gears.

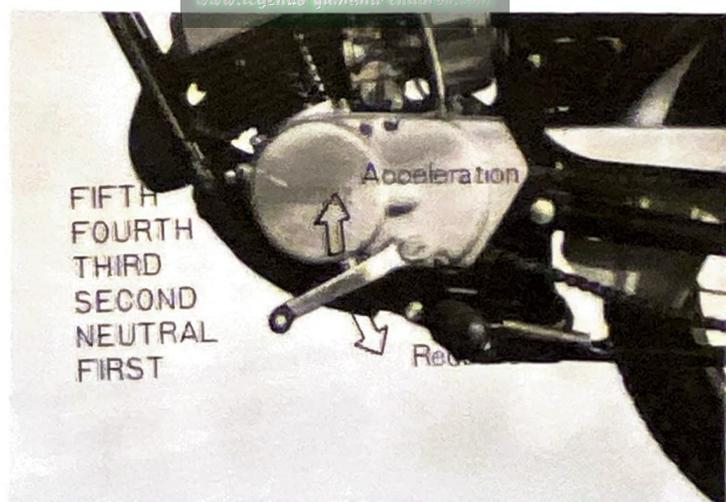

Forward:

- Pull the clutch lever on the lefthand of the handlebar to disengage the clutch.
- Shift into LOW by pushing the change arm down.
- Slowly open the throttle to raise the engine speed, and at the same time, release the clutch lever slowly. Now you are ready to start.

Driving on Roads:

When the speed has reached 10–13 m/h:

- Release the throttle, and at the same time, pull in the clutch lever.
- Shift into SECOND. (Be careful not shift in NEUTRAL.)
- Open the throttle while releasing the clutch lever.

Acceleration will be effected.

- At 13–20 m/h, shift into 3rd. Then follow the table below.
- To decelerate, close the throttle, and pull in the clutch lever and shift into lower gear positions in order.

Gear	Driving Conditions	Optimum Speed
First (Low)	Starting or hill climbing	10 m/h
Second	Going slow or hill climbing	10 to 15 m/h
Third	On easy uphill or in streets	15 to 22 m/h
Fourth	In streets or on roads	20 to 28 m/h
Fifth (Top)	On roads or high-speed running	25 m/h or more

www.legends-yamaha-enduros.com

Driving on Hills:

- When starting to climb a gentle grade, open the throttle little by little to avoid losing engine speed and power.
- When climbing a steep grade, shift down from FIFTH to FOURTH and from FOURTH to THIRD as required to avoid losing engine speed.
- If shifting down is not timely, the engine speed will sharply decrease, and you must further shift down.
Therefore, it is necessary to shift the gears down timely as required.

Going Downhill:

- On a long down grade or sharp descent, don't rely on the brakes alone, but use the so-called engine brake.
- The engine brake is applied in the following way:
Keep both gears and clutch in, and close the throttle. Allow the machine to go downhill. In this case, the engine speed is so slow that in turn the engine is driven by the turning rear wheel.

- The resistance of the rear wheel will produce a braking effect.
- The engine brake is most effective with the gears in low. When descending a gentle grade, the fourth or third gear is recommendable. For a steep downgrade, the third or second gear is better.
 - It is generally said that the gear position for a slope is the same both for going up and down.

Stopping and Parking:

- Shift down in order, and apply the brakes gently to decrease the speed. Be sure to apply both front and rear brakes slowly and at the same time.

Just before topping, shift into NEUTRAL.

- Be sure to apply the front and rear brakes together to stop your machine from high speed running.

Applying only may, under certain conditions, cause skids.

- Keep the fuel cock lever in CLOSE while parking.
- Remove the main switch key.
- Apply the steering lock key.

* If the ground is soft, the machine may fall down with the side stand alone.

5. Operational Notes

(1) Break-in

The Yamaha ENDURO 90 HTI is not only built with extreme accuracy, but is fully tested through trial runs.

However, during the first 625 m, you should observe the following instructions. These simple precautions will prolong the life of the engine and other moving parts.

- During the first 320 m, be sure to keep the engine at below 60 km/h with over top gear.
- During the next 320 m, be sure to keep the engine at below 70 km/h with over top gear.

The relation between speed and gear during the break-in period is given below:

	Over top	Top	3rd	2nd	Low
First 320 m	38	32	25	20	7
Next 320 m	44	38	28	22	10

www.legends-yamaha-enduros.com

(2) Notes on Driving on Paved Roads

The Yamaha ENDURO employs block-pattern tires designed for off-the-road driving. Accordingly, the tire tread is larger than the general one. Be careful not to make a turn with a sharp bank while running at high speed; otherwise, the tires may skid.

(3) Notes on Riding Cross-country

When running over fields, it is advisable that all safety parts be removed to protect them against breakage and damage due to extreme shocks and overturn.

Parts to be removed: Head lamp, tail lamp, speedmeter, battery, and side stand.

(5) Inspection and Service

The regular inspection and maintenance help keep your motorcycle in top condition.

To insure the longer service life of the machine, it is advisable that according to the periodical inspection card, the regular inspection and maintenance be performed by your Yamaha dealer in addition to the daily check and care to be done by yourself.

This will prove to be most helpful in preventing machine trouble and accident.

If you fail to receive the periodical inspection and service as stipulated in the Periodical Inspection Card, you will not be entitled to make claim against machine failures.

1. Periodical Service at Yamaha Dealer's

Have your Yamaha dealer inspect and service your machine according to the periodical inspection card, after one month, 4 months, 8 months, 12 months, from the date of purchase.

Periodical Inspection Guide www.legends-yamaha-enduros.com

No.	Check Point	1st 1 mo.	2nd 4 mos.	3rd 8 mos.	4th 12 mos.	5th & thereafter Every 4 mos.
1	Front & rear brake adjustment	○	○	○	○	○
2	Clutch adjustment	○	○	○	○	○
3	Transmission oil replacement	○	○	○	○	○
4	Greasing		○	○	○	○
5	Battery fluid level check & refilling	○	○	○	○	○
6	Spark plug cleaning	○	○	○	○	○
7	Ignition timing adjustment		○	○	○	○
8	Carburetor adjustment		○	○	○	○
9	Carburetor disassembly & cleaning			○	○	○
10	Air cleaner cleaning		○	○	○	○
11	Cylinder head & piston cleaning		○	○	○	○
12	Muffler cleaning		○	○	○	○
13	Bolts & nuts retightening	○	○	○	○	○
14	Drive chain adjustment	○	○	○	○	○
15	Oil pump setting adjustment	○	○	○	○	○

2. Owner's Inspection

(1) Daily Check

Before riding, the following points should be checked.

a. Is the fuel sufficient for the planned trip?

b. Is the Autolube oil sufficient?

Check for the oil level through the glass port.

c. Is the tire pressure correct?

Incorrect tire pressure affects maneuverability.

d. Do the front and rear brakes work?

Check both brakes by pulling the brake lever or depressing the brake pedal.

e. Do the lights and horn function well?

Make sure that all lights turn on.

(2) Periodical Inspection

It is advisable that the following-listed parts be checked periodically by yourself. You may ask your Yamaha dealer to do this work.

It may be interesting for you to do it yourself with service tools.

The service which is to be performed after the third month, ninth month, fifteenth month, after the date of your purchase is:

1. Front and rear brake adjustment
2. Clutch adjustment
3. Gear oil replacement
4. Battery refilling
5. Spark plug cleaning
6. Carburetor checking
7. Air cleaner cleaning
8. Cylinder head and piston cleaning
9. Muffler cleaning
10. Drive chain adjustment and oiling
11. Bolts and nuts retightening

3. Periodical Inspection with Service Tools

Release the tool box hook, and open the cover.

(1) Service Tools

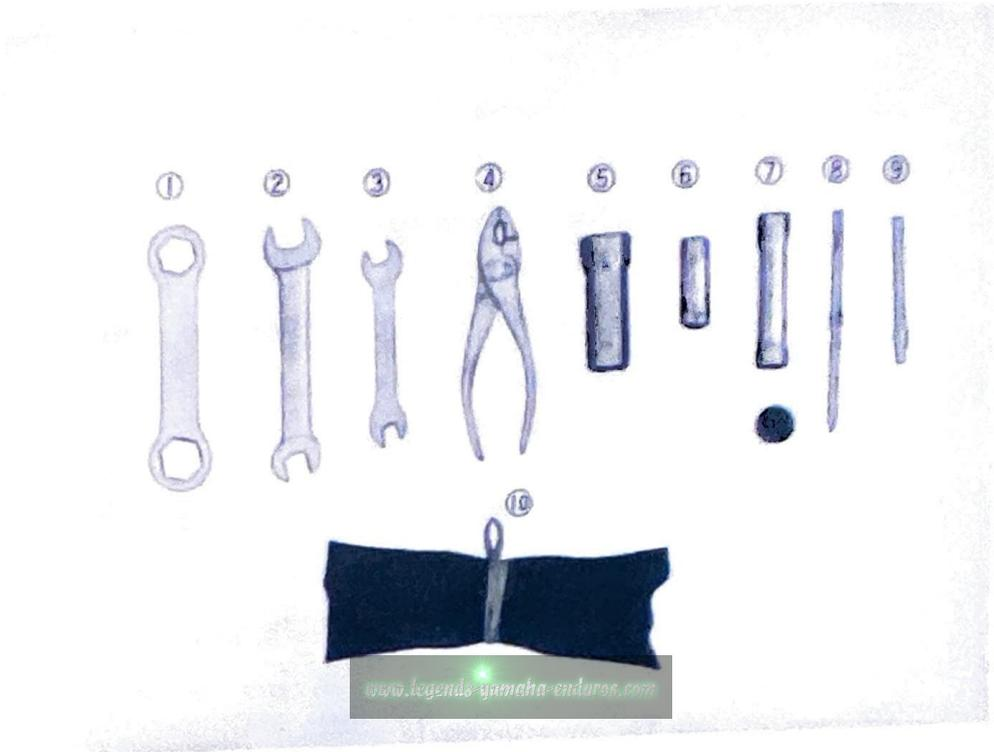

1. Ring spanner 19×22
2. Double-ended spanner 13×17
3. Double-ended spanner 8×10
4. Pliers
5. Box spanner 17×21
6. Box spanner 10
7. Screw driver handle and box spanner 13
8. Screw drivers (slotted head and Philips)
9. Philips screw driver
10. Tool bag

2) Inspection and Service with Service Tools

To perform the daily check and service, the service tools should be used in the following manner.

Adjusting the Brakes

Front Brake:

The correct end play of the brake lever is 0.2 to 0.3 in.

Adjustment should be made by turning the adjusting bolt attached to the lever holder.

After adjustment, be sure to fully tighten the lock nut.

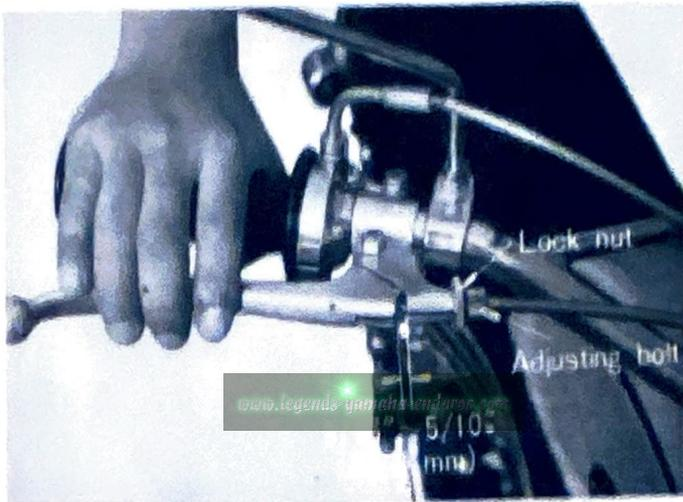

The adjustment can be done at the front brake wire end.

Loosen the lock nut in the same manner as above, and turn the adjusting bolt.

After the adjustment, be sure to fully tighten the lock nut.

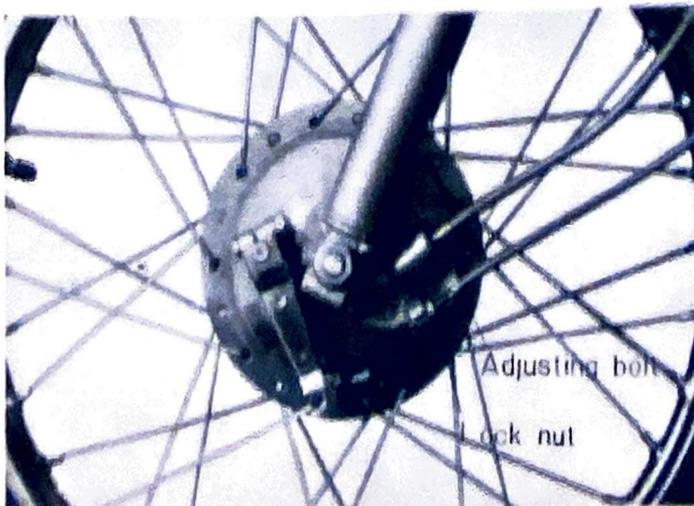

Rear Brake:

The correct end play for the brake pedal is 1 in.

The adjustment should be done by turning the adjusting nut at the end of the rear brake cable a half turn at a time. After the adjustment, make sure that the brake light turns on.

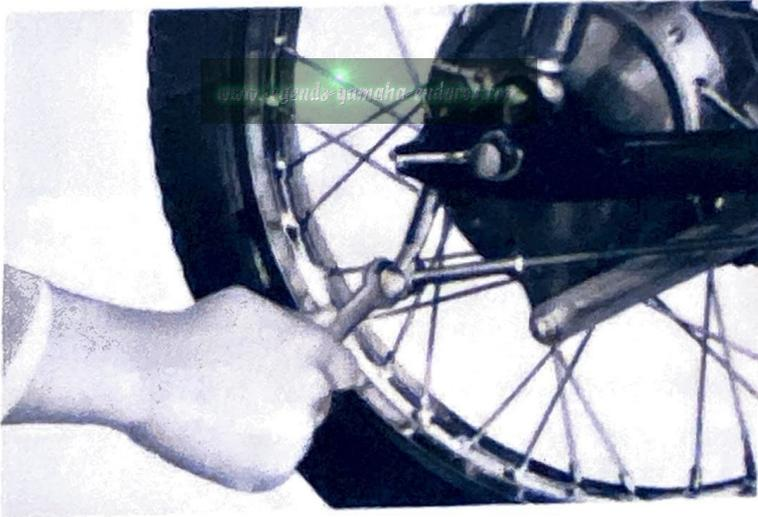
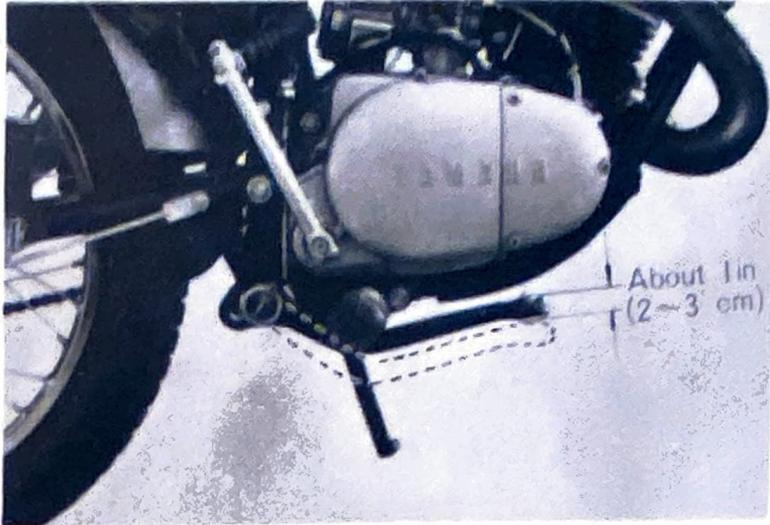

Checking the Brake Lining:

Disassemble the wheel assembly every 2,000 m, and check the brake lining for wear. Clean the brake shoes and brake drum. Take care not to attach oil to the lining friction surface.

Adjusting the Clutch

The correct play for the clutch lever is 0.080 to 0.120 in.

If there is too much end play, the clutch spring will not give pressure to the clutch facing and the clutch may not be disengaged. If there is no end play, the clutch will slip.



Adjustment:

www.legends-yamaha-enduros.com

Adjustment is made by turning the adjusting bolt attached to the lever holder. After the adjustment, be sure to fully tighten the lock nut.

Replacing Gear Oil

Be sure to change the gear oil before it is used up.

During the break-in period, it should be replaced after one month or after the first 320 m, and thereafter, every 1.250 m.

○ To drain the oil, remove the oil drain plug on the crankcase bottom.

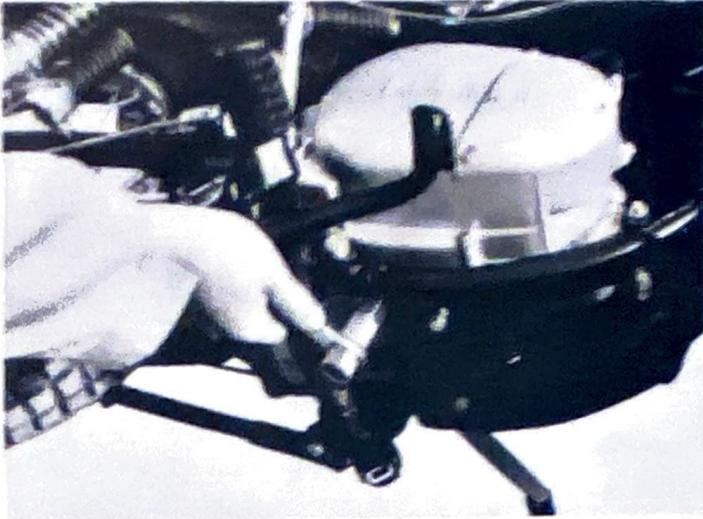

○ Refilling

www.legenda-yamaha-enduros.com

After draining, tighten the drain plug securely.

Feed a specified amount of oil through the oil hold located on the right part of the crankcase cover, in a specified amount.

Yamaha Gear Oil 0.77 ± 0.055 qt.



- Measuring the oil level with an oil level gauge
Insert the oil level gauge into the crankcase (do not screw in), and check for the oil level. If the gauge become wet 0.394 in from the bottom end, the oil level is correct.

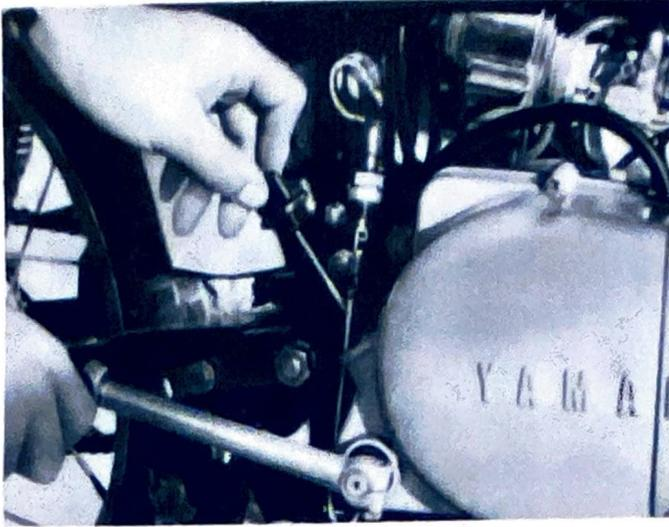

Notes on Battery Mounting

When mounting the battery, the wires should be connected as shown below:

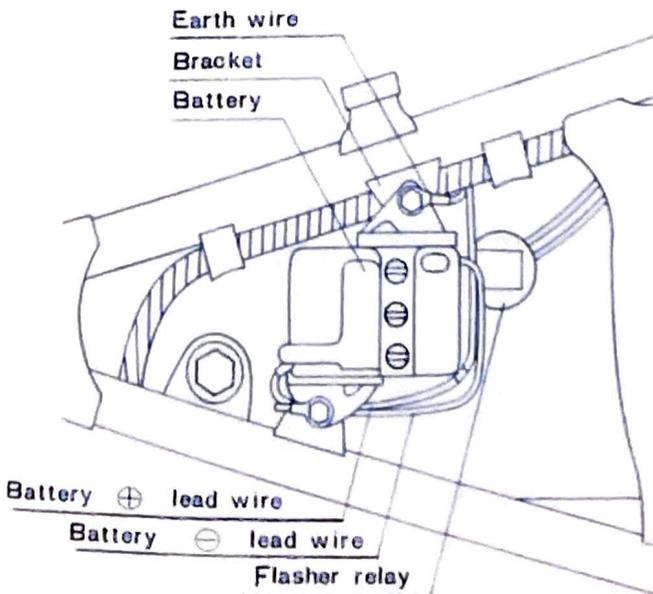

Checking the Battery Fluid

If the battery fluid level is below the lower level line, remove the battery, and add distilled water up to the upper level line. Check the exhaust tube for clogging or kink.



If your motorcycle will not be used for more than a month:

- Remove the battery from the machine, and give it to your Yamaha dealer, or keep it in a dry cool place.
- Be sure to have your dealer charge it once a month.

Checking the Spark Plug

A spark plug ignites the fuel-air mixture in the cylinder. Carboned or oiled plugs cause hard starting, misfiring and other problems.

Remove the spark plug from time to time, and clean the electrodes and adjust the spark plug gap.

- Remove carbon from the electrodes by using a wire brush or a wire.
- Adjust the spark plug gap to 0.020–0.024 in.

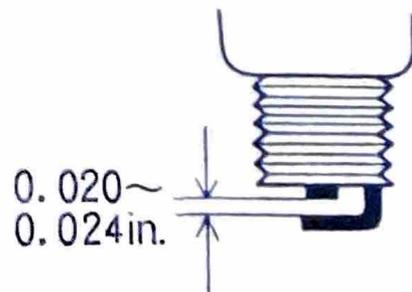

Commendable standard spark plug:

B-8HC

If the insulator has a tan color, the plug is correct.

If sooty, replace the plug with a hotter type. If you habitually run in urban areas at a relatively low speed, the plug will tend to be sooty. A hotter type plug should be used.

NGK B-8H

For a motocross event, a colder type is recommended.

NGK B-9H

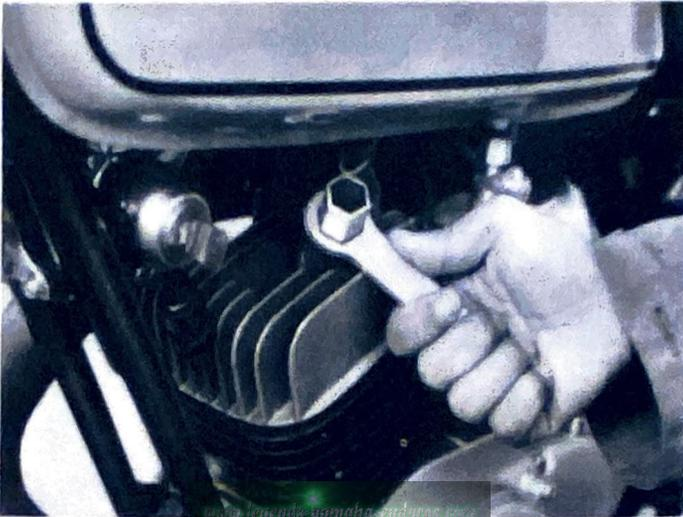

Removing the Air Cleaner

1. Loosen the screws setting the carburetor and air cleaner.
2. Remove the screws holding the frame and cleaner, and the air cleaner can be removed.
3. Remove the cleaner cap, and take out the element.

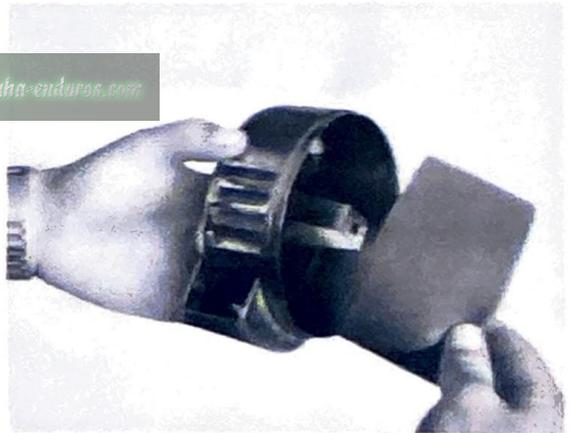
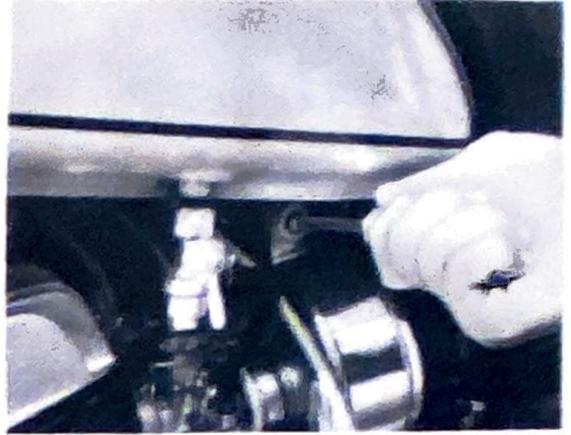

○Cleaning the element

The air cleaner is of a wet multi-plane type.

Accordingly, the element can be cleaned with gasoline, and should be damped with kerosene. If you often drive over a dusty road, the air cleaner should be cleaned once a month.

Checking the Carburetor

The carburetor settings are done under rigid test conditions, and therefore, if they are changed, it may result in poor performance. The following points are allowed to be checked by yourself, but it is advisable that the carburetor be checked by your Yamaha dealer.

a. Idle speed adjustment

- Back out the pilot air screw (1) $1\frac{3}{4}$ turns, and set it.
- Start the engine and warm it up.
- After warming-up, turn the throttle adjust screw (2), and increase the engine speed to 1,200–1,300 rpm.
- Adjust the play of the accelerator cable 0.117 to 0.039 in by turning the adjusting bolt 4.

b. Adjusting the pump cable

- After adjustment of the carburetor, adjust the pump cable coupled with the accelerator grip.
- Turn out the accelerator grip so that the throttle cable play will be removed.
- Then, turn the pump cable adjusting nut so that the adjusting pulley's mark will match the guide pin.

(Carburetor Setting)

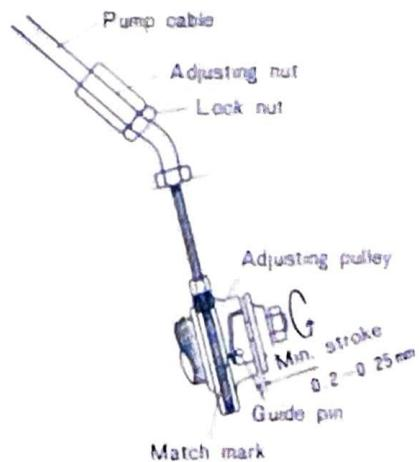
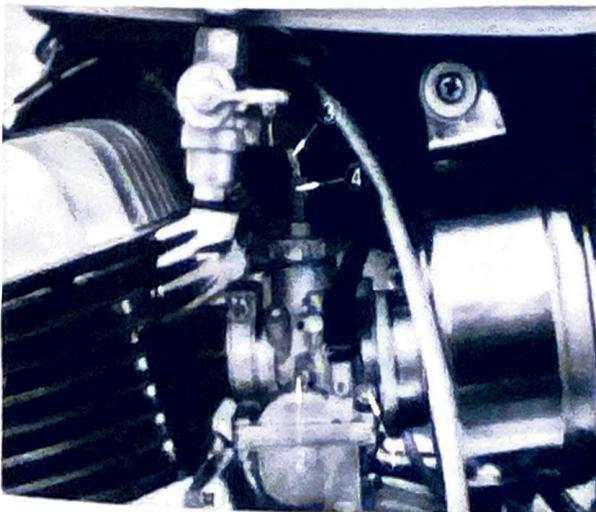

Adjusting and Lubricating the Drive Chain

The drive chain should have 0.788–1.18 in of up and down play measured at the center of the lower section of the chain with the rear wheel on the ground. A dirty or dry chain will wear rapidly and seize up. Periodically oil it. Check the chain regularly to make sure that it is properly oiled and adjusted. It is wise to wash the chain off with gasoline before reoiling.

Adjustment:

- a. Loosen the rear brake adjusting nut.
- b. Loosen the rear wheel shaft 1.
- c. Turn the adjusting nut 2, and move the axle so that the adjusting marks on each side are in the same position.
- d. After adjustment, fully tighten the adjusting nut 1.

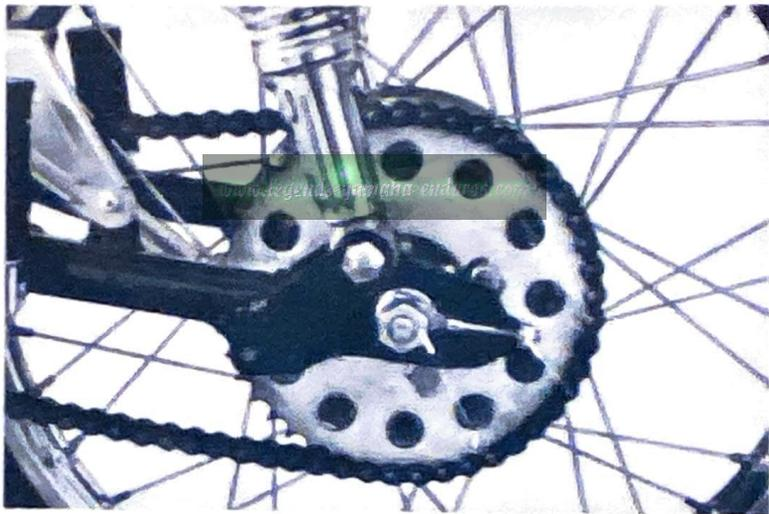

After the chain tension is adjusted, check for brake pedal play and stop light.

Cleaning the Muffler

To remove the inner cylinder from the muffler, remove the cylinder set screw and pull the silencer out. Remove the carbon with a wire brush, and lightly tap the cylinder. If the carbon is hard to be removed, heat the cylinder with a torch lamp, and tap it lightly. The carbon can easily be removed.

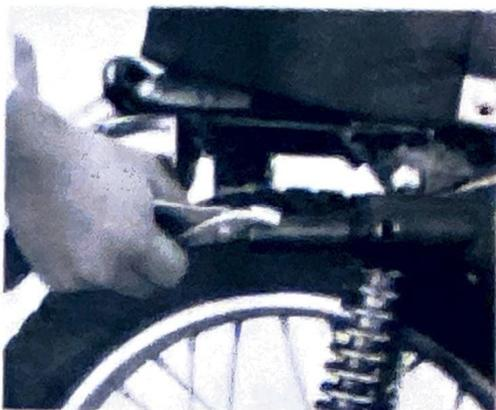

Cleaning the Cylinder Head and Piston

Carbon accumulation around the cylinder head and piston causes poor performance, loss of power, www.legendaryyamaha-enduros.com and engine knocking.

- Remove the cylinder head, and remove all carbon from the combustion chamber.
- Remove all carbon from the piston crown.

Use a wire brush or screwdriver, and after removing the carbon, wipe the piston with a cloth damped with gasoline.



Cleaning the Fuel Cock Filter

The fuel cock filter removes impurities from the gasoline before it reaches the carburetors. A dirty filter will lead to the clogging of the carburetor, and poor engine performance will result. The filter, therefore, should be cleaned from time to time.

- Remove the cup from the fuel cock and then the filter.
Wash it carefully in gasoline.



Adjusting the Headlight Beam Angle

- To adjust the headlight beam angle, loosen the light mounting nut in the headlight, and move the light to face upward or downward.

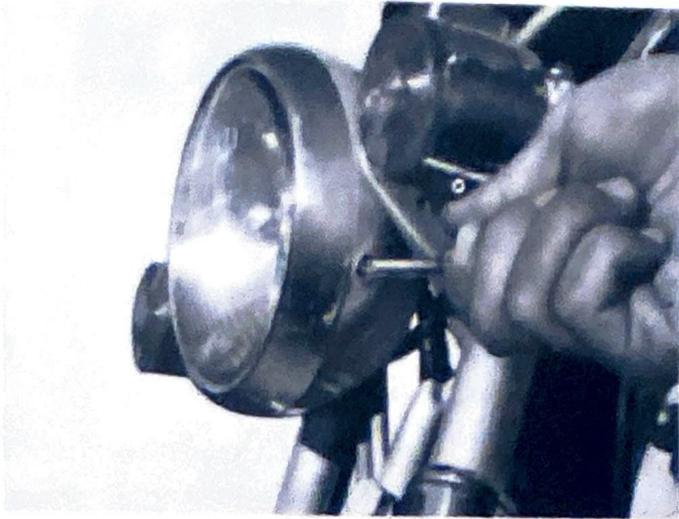

Retightening Bolts and Nuts

Check all bolts and nuts for looseness. If necessary, retighten them. Front axle, rear axle, swing arm shaft, front fork steering, rear cushion, engine fittings, handlebar, air cleaner case, battery case, fuel tank, front fender, rear fender, head light, tail light, etc.

MEMO

www.legends-yamaha-enduros.com

MEMO

www.legendes-gamela-enduros.com

MEMO

www.legenda-yamaha-enduros.com

Stopping Distance

This figure indicates braking performance that can be met or exceeded by the vehicles to which it applies, without locking the wheels, under different conditions of loading and with partial failures of the braking system. The information presented represents results obtainable by skilled drivers under controlled road and vehicle conditions, and the information may not be correct under other conditions.

Description of vehicles to which this table applies: YAMAHA HTI Motor cycle

A. Fully Operational Service Brake

Load

Light

Maximum

190

215

0

100

200

300

www.legends-yamaha-enduros.com

Stopping Distance in Feet from 60 mph

Acceleration and passing ability

This figure indicates passing times and distances that can be met or exceeded by the vehicles to which it applies, in the situations diagrammed below.

The low-speed pass assumes an initial speed of 20 mph and a limiting speed of 35 mph. The high-speed pass assumes an initial speed of 50 mph and a limiting speed of 80 mph.

NOTICE: The information presented represents results obtainable by skilled drivers under controlled road and vehicle conditions, and the information may not be correct under other conditions.

Description of vehicles to which this table applies: YAMAHA HTI Motor cycle

Summary table:

Low-speed pass..... 385 feet; 8.4 seconds

High-speed pass..... 2,600 feet; 32 seconds

LOW-SPEED

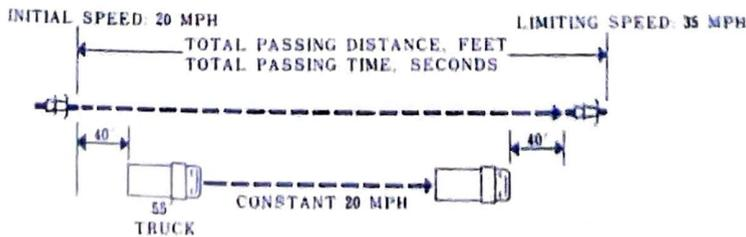

HIGH-SPEED

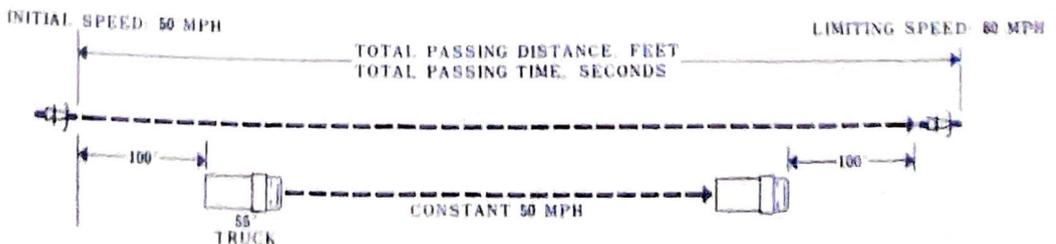

Yamaha ENDURO 90 HTI Wiring Diagram

Battery output	Red
Common output	Brown
Magneto (day) output	Green
Magneto (night) output	Yellow
Light output	Blue
Horn output	Pink
Earth output	Black

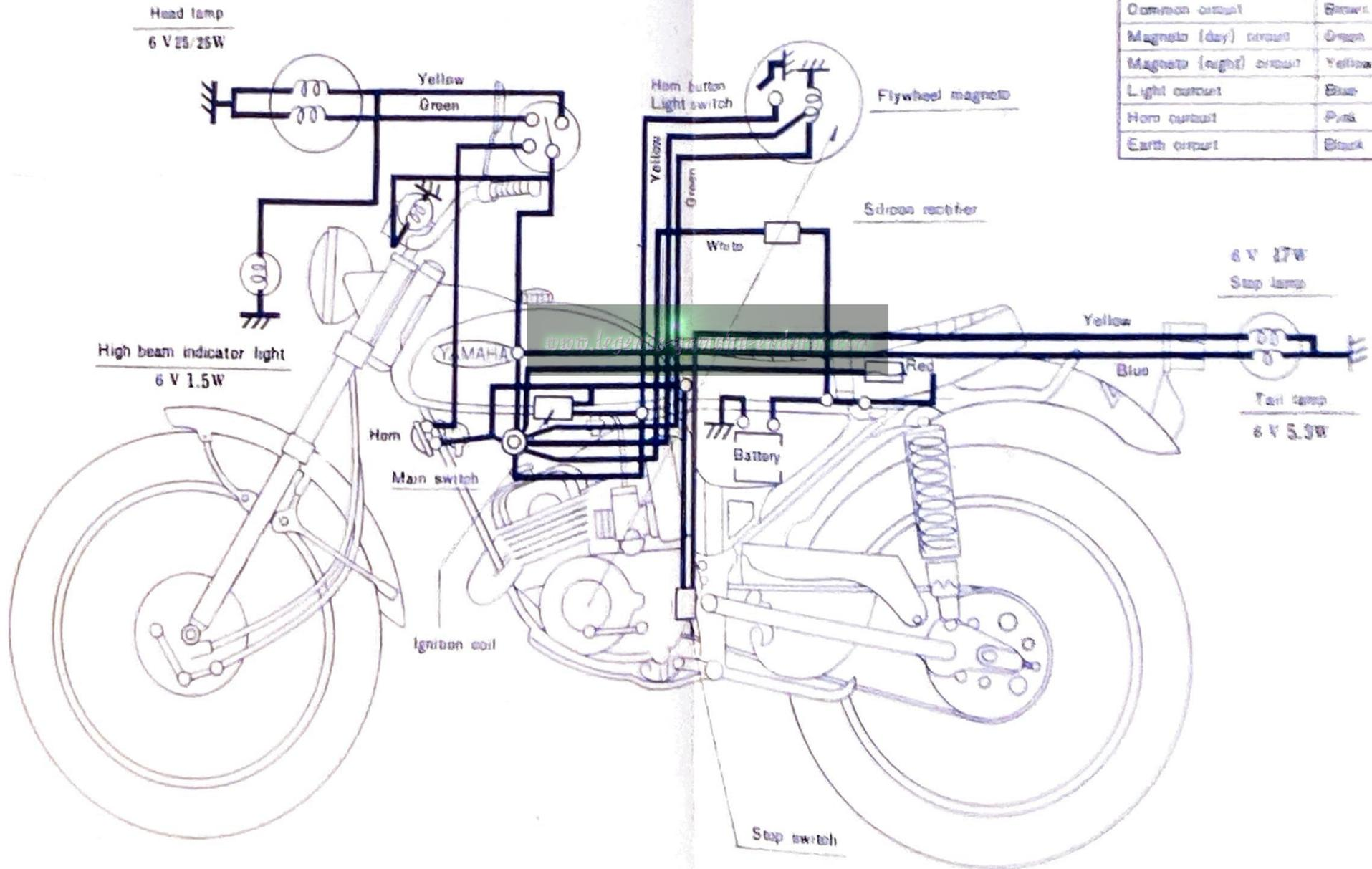

www.legends-yamaha-enduros.com



YAMAHA MOTOR CO., LTD.

PRINTED IN JAPAN