



YAMAHA

www.legends-yamaha-enduros.com

OWNER'S MANUAL

RT100D

LIT-11626-08-23

3UL-28199-12

AFFIX DEALER

www.legends-yamaha-enduros.com

LABEL HERE

A-000

RT100D

OWNER'S MANUAL

©1991 by Yamaha Motor Corporation, U.S.A.

1st Edition, August 1991

**All rights reserved. Any reprinting or
unauthorized use without the written
permission of Yamaha Motor Corporation,
U.S.A. is expressly prohibited.**

Printed in Japan

P/N LIT-11626-08-23

⚠ WARNING

THIS MACHINE IS DESIGNED AND MANUFACTURED FOR OFF-ROAD USE ONLY. IT IS ILLEGAL TO OPERATE THIS MACHINE ON ANY PUBLIC STREET, ROAD OR HIGHWAY. SUCH USE IS PROHIBITED BY LAW. THIS MACHINE COMPLIES WITH ALMOST ALL STATE OFF-HIGHWAY NOISE LEVEL AND SPARK ARRESTER LAWS AND REGULATIONS. PLEASE CHECK YOUR LOCAL RIDING LAWS AND REGULATIONS BEFORE OPERATING THIS MACHINE.

INTRODUCTION

Congratulations on your purchase of the Yamaha RT100D. This model is the result of Yamaha's vast experience in the production of fine sporting, touring, and pacesetting racing machines. It represents the high degree of craftsmanship and reliability that have made Yamaha a leader in these fields.

This manual will give you an understanding of the operation, inspection, and basic maintenance of this machine. If you have any questions about the operation or maintenance of your machine, please consult a Yamaha dealer.

U-001

NOTE:

Some data in this manual may become outdated due to future improvement on this model. If you have any questions about this manual or your machine, please consult a Yamaha dealer.

A-100

U-600

WARNING

PLEASE READ THIS MANUAL CAREFULLY AND COMPLETELY BEFORE OPERATING THIS MACHINE. DO NOT ATTEMPT TO OPERATE THIS MACHINE UNTIL YOU HAVE ATTAINED A SATISFACTORY KNOWLEDGE OF ITS CONTROLS AND OPERATING FEATURES AND UNTIL YOU HAVE BEEN TRAINED IN SAFE AND PROPER RIDING TECHNIQUES. REGULAR INSPECTIONS AND CAREFUL MAINTENANCE, ALONG WITH GOOD RIDING SKILLS, WILL ENSURE THAT YOU SAFELY ENJOY THE CAPABILITIES AND THE RELIABILITY OF THIS MACHINE.

Particularly important information is distinguished in this manual by the following notations:



The Safety Alert Symbol means **ATTENTION! BECOME ALERT! YOUR SAFETY IS INVOLVED!**

! WARNING

Failure to follow **WARNING** instructions could result in severe injury or death to the machine operator, a bystander or a person inspecting or repairing the machine.

CAUTION:

A **CAUTION** indicates special precautions that must be taken to avoid damage to the machine.

NOTE:

A **NOTE** provides key information to make procedures easier or clearer.

U-000

NOTE: _____

This manual should be considered a permanent part of this machine and should remain with it even if the machine is subsequently sold.

CONTENTS

SAFETY INFORMATION	1-1	Kick starter	5-4
LOCATION OF THE IMPORTANT LABELS	2-1	Seat	5-4
DESCRIPTION.....	3-1	Side cover removal	5-5
MACHINE IDENTIFICATION	4-1	Rear shock absorber	5-5
Vehicle identification number.....	4-1	PRE-OPERATION CHECKS.....	6-1
Engine serial number	4-1	Brakes	6-3
CONTROL FUNCTIONS	5-1	Clutch	6-3
Handlebar switch.....	5-1	Throttle grip	6-3
Clutch lever	5-1	Engine oil	6-3
Shift pedal.....	5-2	Transmission oil	6-4
Front brake lever	5-2	Chain.....	6-4
Rear brake pedal	5-2	Tires	6-5
Fuel tank cap	5-2	Wheels	6-6
Fuel cock	5-3	Accessories or replacement parts	6-7
Starter knob (CHOKE)	5-3	Fittings/Fasteners	6-7
		Fuel	6-8
		Fuel tank breather hose	6-9

OPERATION AND INPORTANT

RIDING POINTS	7-1
Starting and warming up a cold engine	7-1
Starting a warm engine	7-2
Shifting	7-2
To start out and accelerate	7-3
To decelerate	7-3
Engine break-in	7-4
Parking	7-5

PERIODIC MAINTENANCE AND

MINOR REPAIR	8-1
Tool kit.....	8-2
Periodic maintenance/lubrication	8-3
Spark plug inspection.....	8-5
Torque specifications.....	8-7
Transmission oil level check	8-8
Tramsmission oil replacement	8-9
Air filter	8-10
Carburetor adjustment.....	8-12
Idle speed adjustment.....	8-12

Throttle cable adjustment	8-13
Front brake adjustment.....	8-14
Rear brake adjustment.....	8-15
Brake lining inspection	8-15
Clutch adjustment	8-16
Free play adjustment	8-16
Drive chain slack check	8-17
Drive chain slack adjustment.....	8-17
Drive chain lubrication	8-19
Cable inspection and lubrication.....	8-20
Throttle cable and grip lubrication ...	8-20
Autolube pump adjustment.....	8-20
Brake and shift pedals	8-21
Brake and clutch levers	8-21
Sidestand	8-21
Rear suspension	8-21
Front fork inspection	8-21
Rear shock absorber adjustment	8-22
Steering inspection.....	8-23
Wheel bearings	8-24
Front wheel removal.....	8-24
Front wheel installation.....	8-24

Rear wheel removal	8-25
Rear wheel installation	8-27
Troubleshooting	8-27
Troubleshooting chart	8-28
CLEANING AND STORAGE.....	9-1
A. Cleaning	9-1
B. Storage	9-2
SPECIFICATIONS	10-1
MOTORCYCLE NOISE REGULATION.....	11-1
MAINTENANCE RECORD	12-1
OFF-ROAD MOTORCYCLE LIMITED WARRANTY	13-1
WIRING DIAGRAM	14-1

⚠ SAFETY INFORMATION

TWO-WHEELED MACHINES ARE SINGLE TRACK VEHICLES. THEIR SAFE USE AND OPERATION ARE DEPENDENT UPON THE USE OF PROPER RIDING TECHNIQUES AS WELL AS THE EXPERTISE OF THE OPERATOR.

EVERY OPERATOR SHOULD KNOW THE FOLLOWING REQUIREMENTS BEFORE RIDING.

HE OR SHE SHOULD:

- 1. OBTAIN THOROUGH INSTRUCTIONS FROM A COMPETENT SOURCE ON ALL ASPECTS OF MACHINE OPERATION.**
- 2. OBSERVE THE WARNINGS AND MAINTENANCE REQUIREMENTS IN THE OWNER'S MANUAL.**
- 3. OBTAIN QUALIFIED TRAINING IN SAFE AND PROPER RIDING TECHNIQUES.**
- 4. OBTAIN PROFESSIONAL TECHNICAL SERVICE AS INDICATED BY THE OWNER'S MANUAL AND/OR WHEN MADE NECESSARY BY MECHANICAL CONDITIONS.**

SAFE RIDING

- 1. Always make pre-operation checks. Careful checks may help prevent an accident.**
- 2. This machine is designed for off-road use only. It is illegal for this machine to be operated on any public street, road, or highway. Off-road use on public lands may be illegal. Please check local regulations before riding.**
- 3. This machine is designed to carry the operator only. No passengers.**
- 4. Many accidents involve inexperienced operators.**
 - a. Know your skills and limits. Staying within your limits may help you to avoid an accident.**
 - b. Only lend your machine to experienced operators.**
- 5. Many machine accidents have been caused by machine operator errors. A typical error made by the operator is veering wide on a turn due to EXCESSIVE SPEED or undercornering (insufficient lean angle for the speed). Never travel faster than warranted by conditions.**
- 6. Ride cautiously in unfamiliar areas. You may encounter hidden obstacles which could cause an accident.**

7. The operator's posture is important for proper control. The operator should keep both hands on the handlebars and both feet on the operator footrests during operation to maintain control of the machine.
8. Never ride under the influence of alcohol or drugs.

PROTECTIVE APPAREL

The majority of fatalities from machine accidents are the result of head injuries. The use of a safety helmet is the single most critical factor in the prevention or reduction of head injuries.

1. Always wear an approved helmet.
2. Wear a face shield or goggles. Wind on your unprotected eyes could contribute to an impairment of vision which could delay seeing a hazard.
3. The use of heavy boots, jacket, trousers, gloves, etc. is effective in preventing or reducing abrasions or lacerations.
4. Never wear loose fitting clothing. It could catch on the control levers, footrests, or wheels and cause injury or accident.
5. Never touch the engine or exhaust system during or after operation. They become very hot and can cause burns. Always wear protective clothing that covers your legs, ankles, and feet.

MODIFICATION

Modifications made to the machine not approved by Yamaha, or the removal of original equipment, may render your machine unsafe for use and may cause severe personal injury. Modifications may also make your machine illegal to use.

LOADING AND ACCESSORIES

Adding accessories or cargo to your machine can adversely affect stability and handling if the weight distribution of the machine is changed. To avoid the possibility of an accident, extreme caution should be used if adding cargo or accessories to your machine. Use extra care if riding a machine which has added cargo or accessories.

Genuine Yamaha accessories have been specifically designed for use on this machine. Since Yamaha cannot test all other accessories which may be available, you must personally be responsible for the proper selection, installation and use of non-Yamaha accessories. You should use extreme caution when selecting and installing any accessories.

Keep in mind these guidelines:

- 1. Never install accessories or carry cargo that would impair the performance of your machine. Carefully inspect the accessory before using it to make sure it does not in any way reduce ground clearance or cornering clearance, limit suspension travel, steering travel or control operation.**
 - a. Accessories fitted to the handlebar or the front fork area can create instability due to improper weight distribution or aerodynamic changes. If accessories are added to the handlebar or front fork area, they must be as lightweight as possible and should be kept to a minimum.**
 - b. Certain accessories can displace the operator from his or her normal riding position. This improper position limits the freedom of movement of the operator and may limit control ability. Therefore such accessories are not recommended.**

GASOLINE AND EXHAUST GAS

- 1. GASOLINE IS HIGHLY FLAMMABLE:**
 - a. Always turn off the engine when refueling.**
 - b. Take care not to spill any gasoline on the engine or exhaust pipe(s)/muffler(s) when refueling.**
 - c. Never refuel while smoking or in the vicinity of an open flame.**
- 2. Never start the engine or let it run for any length of time in a closed area. The exhaust fumes are poisonous and may cause loss of consciousness and death within a short time. Always operate your motorcycle in an area that has adequate ventilation.**
- 3. Always turn off the engine before leaving the machine unattended. When parking the machine, note the following:**
 - a. The engine and exhaust pipe(s)/muffler(s) may be hot. Park the machine in a place where pedestrians or children are not likely to touch these hot areas.**
 - b. Do not park the machine on a slope or soft ground; the machine may fall over.**
 - c. Do not park the machine near a flammable source, e.g. a kerosene heater, or near an open flame. The machine could catch fire.**

- 4. When transporting the machine in another vehicle, be sure it is kept upright and that the fuel cock(s) is turned to "OFF". If it should lean over, gasoline may leak out of the carburetor or fuel tank.**
- 5. If you should swallow any gasoline, inhale a lot of gasoline vapor, or allow gasoline to get in your eye(s), see your doctor immediately. If any gasoline spills on your skin or clothing, immediately wash it off with soap and water and change your clothes.**

LOCATION OF THE IMPORTANT LABELS

Please read following labels carefully before operating this machine.

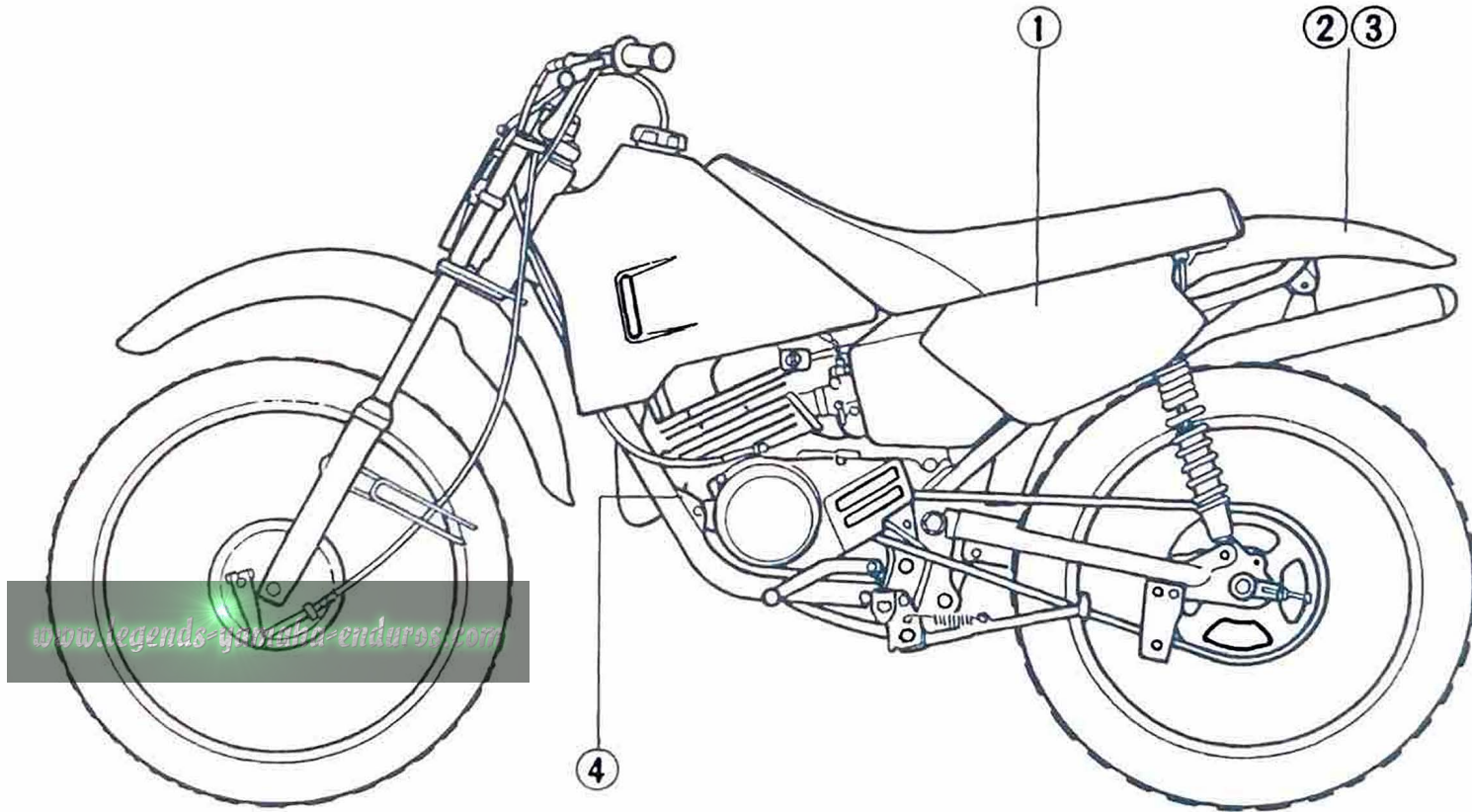

①

⚠ WARNING

- **BEFORE YOU OPERATE THIS VEHICLE, READ THE OWNER'S MANUAL AND ALL LABELS.**
- **NEVER CARRY A PASSENGER.** You increase your risk of losing control if you carry a passenger.
- **NEVER OPERATE THIS VEHICLE ON PUBLIC ROADS.** You can collide with another vehicle if you operate this vehicle on a public road.
- **ALWAYS WEAR AN APPROVED MOTORCYCLE HELMET,** eye protection, and protective clothing.

3XJ-2118K-00

②

⚠ WARNING

Riding as a passenger can cause the vehicle to go out of control.

Loss of control can cause a collision or rollover, which can result in severe injury or death.

NEVER ride as a passenger.

YAMAHA

3XJ-2151H-00

③

TIRE INFORMATION

Cold tire normal pressure should be set as follows.

FRONT : 125 kPa, {1.25 kgf/cm²}, 18 psi

REAR : 125 kPa, {1.25 kgf/cm²}, 18 psi

YAMAHA

3UL-21668-00

④

MOTORCYCLE NOISE EMISSION CONTROL INFORMATION. YAMAHA MOTOR CO., LTD

YAMAHA

THIS MOTORCYCLE MEETS **** AND LATER EPA NOISE EMISSION REQUIREMENTS OF THE FEDERAL TEST PROCEDURE. MODIFICATIONS WHICH CAUSE THIS MOTORCYCLE TO EXCEED FEDERAL NOISE STANDARD ARE PROHIBITED BY FEDERAL LAW SEE OWNER'S MANUAL.

LIMIT/CLOSING : *** dBA/**** r/min MODEL CODE : ****

DESCRIPTION

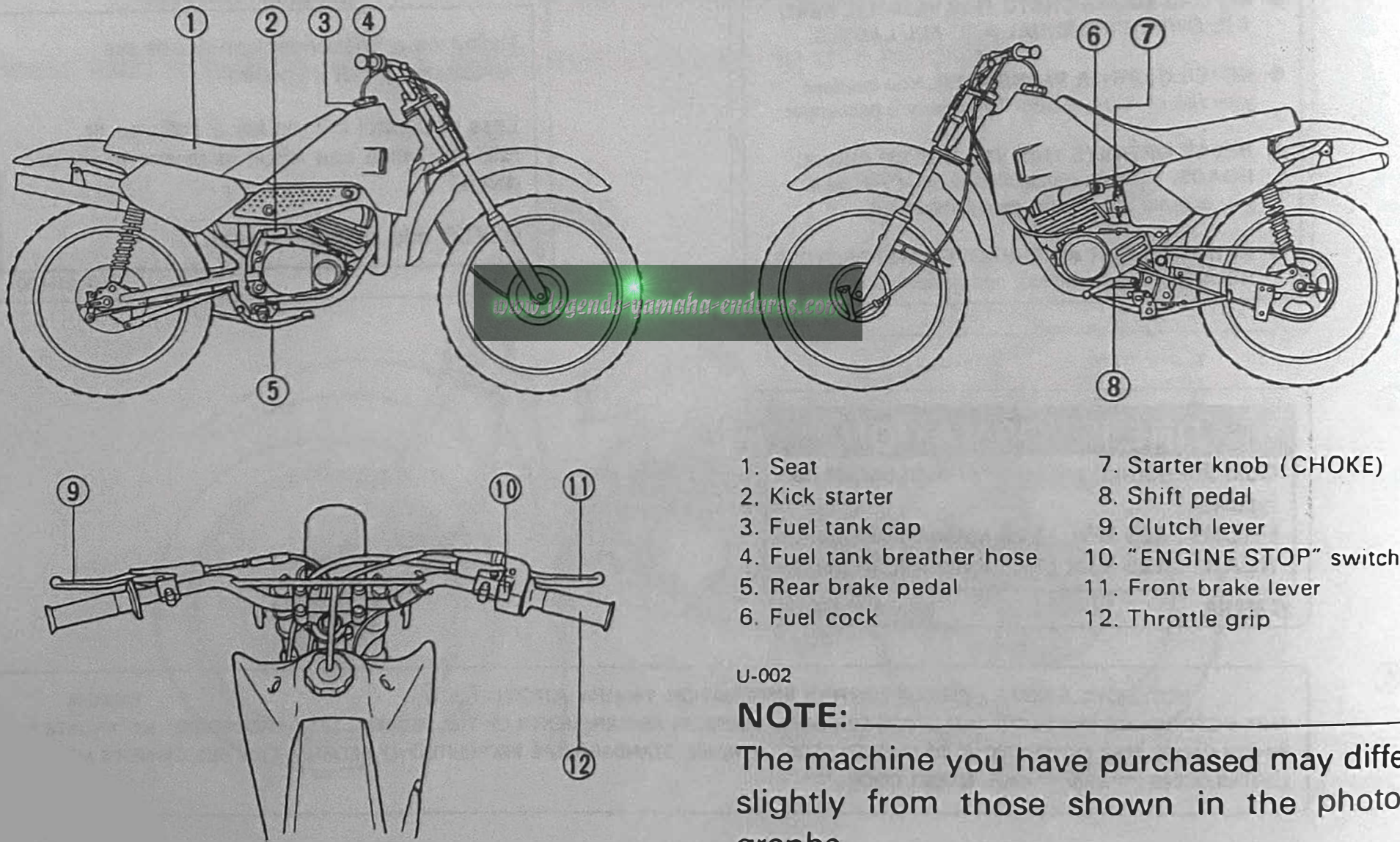

- | | |
|----------------------------|--------------------------|
| 1. Seat | 7. Starter knob (CHOKE) |
| 2. Kick starter | 8. Shift pedal |
| 3. Fuel tank cap | 9. Clutch lever |
| 4. Fuel tank breather hose | 10. "ENGINE STOP" switch |
| 5. Rear brake pedal | 11. Front brake lever |
| 6. Fuel cock | 12. Throttle grip |

U-002

NOTE: _____
 The machine you have purchased may differ slightly from those shown in the photographs.

A-601

MACHINE IDENTIFICATION

A-800

Vehicle identification number

The vehicle identification number is stamped into the steering head pipe.

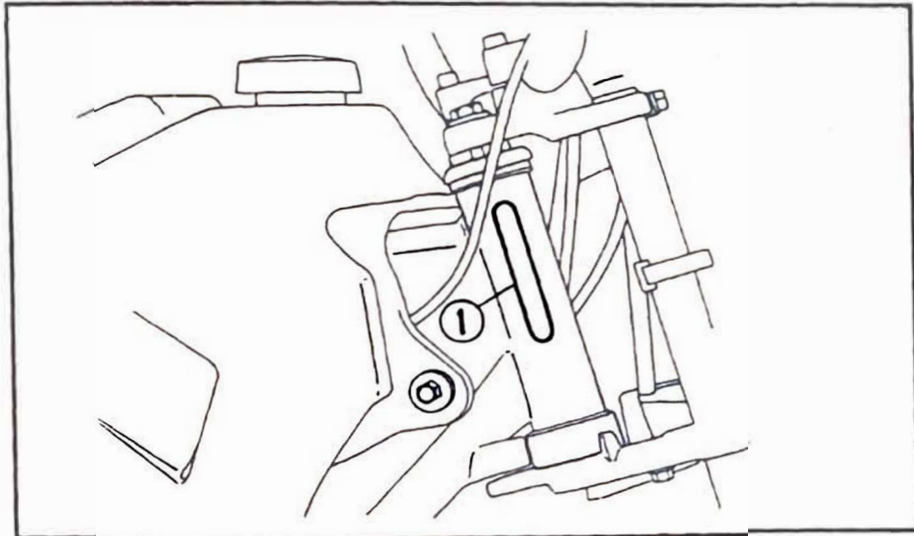

1. Vehicle identification number

U-004

NOTE: _____

The vehicle identification number is used to identify your machine and may be used to register your machine with the licensing authority in your state.

A-701

Engine serial number

The engine serial number is stamped into the right side of the engine.

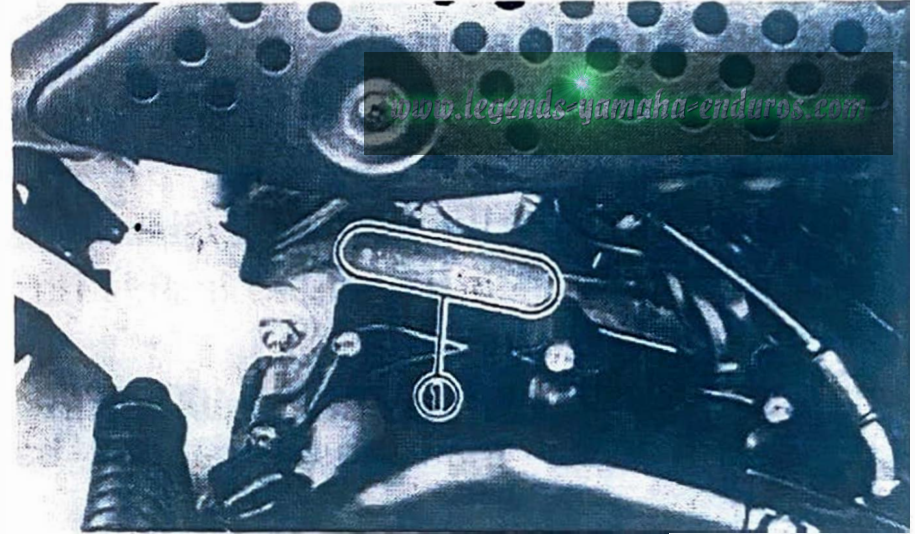

1. Engine serial number

U-003

NOTE: _____

The first three digits of these numbers are for model identification; the remaining digits are the unit production number. Keep a record of these numbers for reference when ordering parts from a Yamaha dealer.

B-000

CONTROL FUNCTIONS

B-600

Handlebar switch:

“ENGINE STOP” switch

The engine stop switch is located on the right handlebar.

This switch controls the ignition system.

RUN: The engine can be started in this position.

OFF: The engine can be stopped in this position. Also the engine cannot be started.

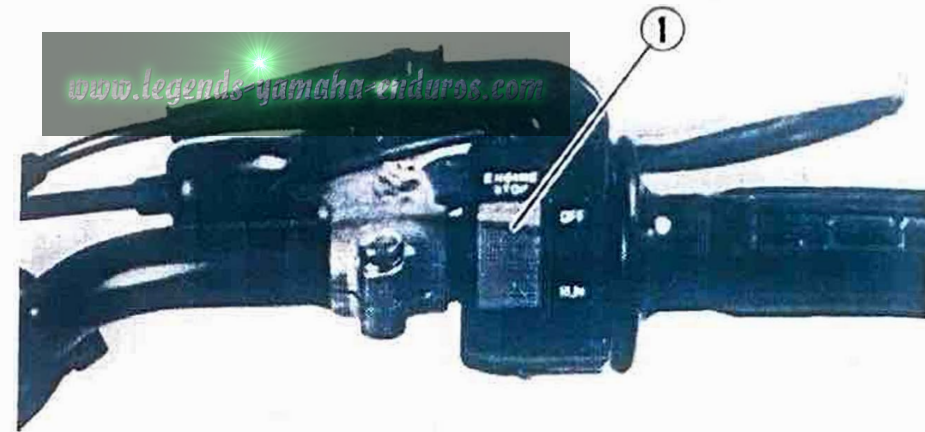

1. “ENGINE STOP” switch

B-701

Clutch lever

The clutch lever is located on the left handlebar; it disengages or engages the clutch. Pull the clutch lever to the handlebar to disengage the clutch, and release the lever to engage the clutch. The lever should be pulled rapidly and released slowly for smooth starts.

B-800

Shift pedal

The gear ratios of the constant-mesh 5-speed transmission are ideally spaced. The gears can be shifted by using the shift pedal on the left side of the engine.

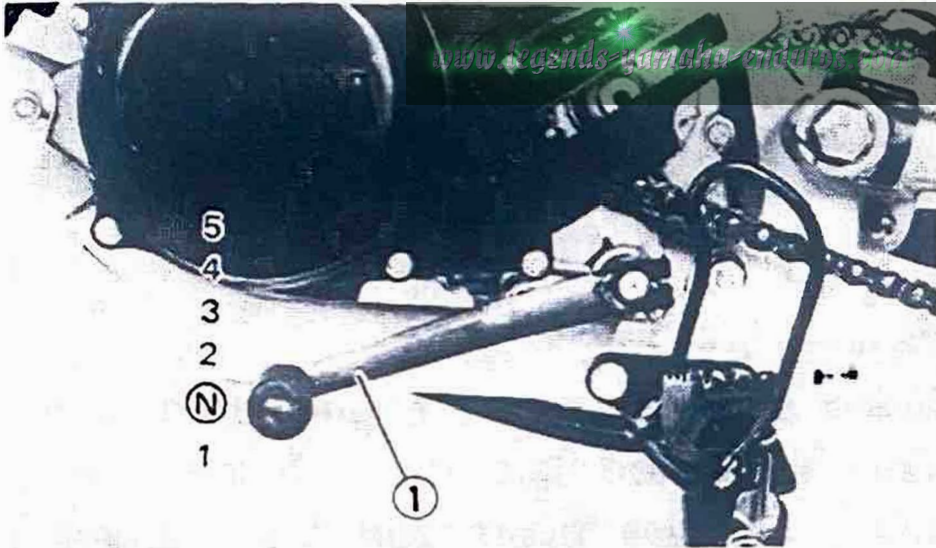

N. Neutral

1. Shift pedal

B-900

Front brake lever

The front brake lever is located on the right handlebar. Pull it toward the handlebar to activate the front brake.

B-901

Rear brake pedal

The rear brake pedal is on the right side of the machine. Press down on the brake pedal to activate the rear brake.

Fuel tank cap

Remove the fuel tank cap by turning it counterclockwise.

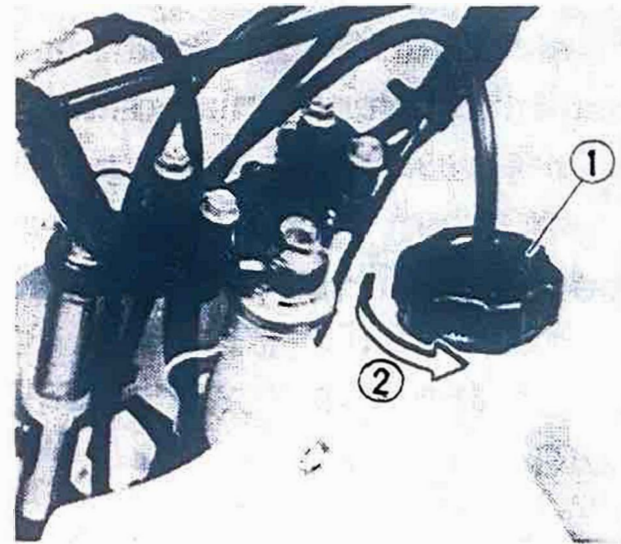

1. Fuel tank cap

2. Open

Fuel cock

The fuel cock supplies fuel from the tank to carburetor while filtering the fuel. The fuel cock has the three positions:

OFF: With the lever in this position, fuel will not flow. Always return the lever to this position when the engine is not running.

ON: With the lever in this position, fuel flows to the carburetor. Normal riding is done with the lever in this position.

RES: This indicates reserve. If you run out of fuel while riding, move the lever to this position. **FILL THE TANK AT THE FIRST OPPORTUNITY. BE SURE TO SET THE LEVER TO "ON" AFTER REFUELING.**

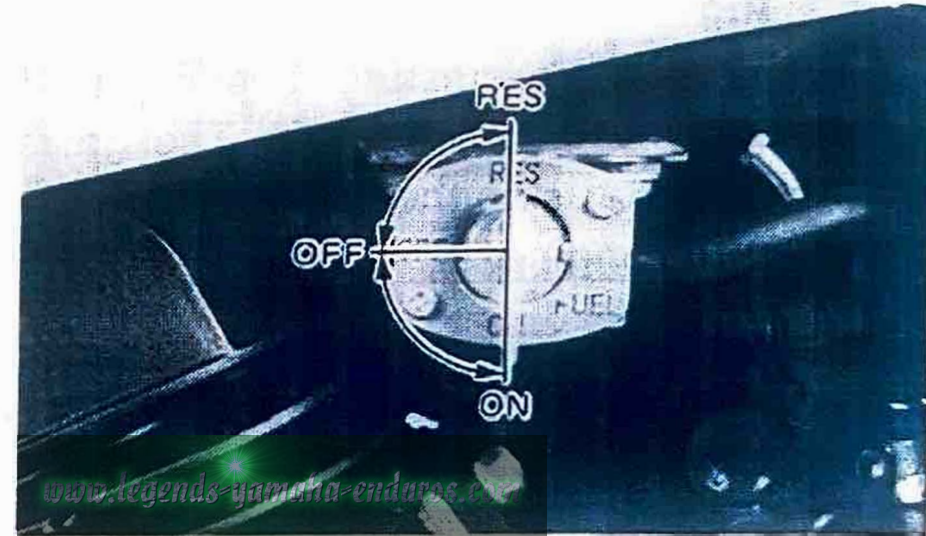

Starter knob (CHOKE)

When cold, the engine requires a richer air-fuel mixture for starting. A separate starter circuit supplies this mixture. Pull the starter knob out to open the circuit for starting. When the engine has warmed up, push the knob in to close the circuit.

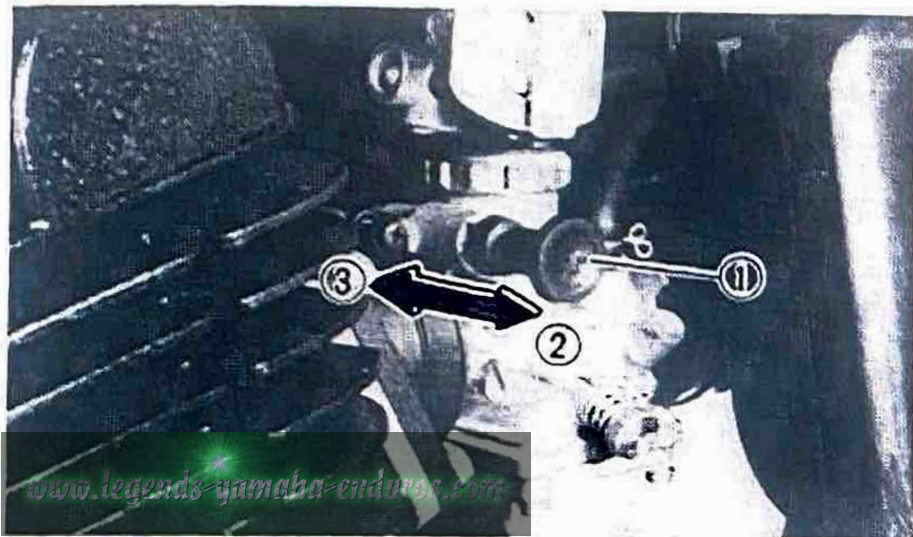

- 1. Starter knob (CHOKE)
- 2. Open the circuit
- 3. Close the circuit

C-602

Kick starter

Rotate the kick starter away from the engine. Push the starter down lightly with your foot until the gears engage, then kick smoothly and forcefully to start the engine. This model has a primary kick starter so the engine can be started in any gear if the clutch is disengaged. In normal practices, however, shift to neutral before starting.

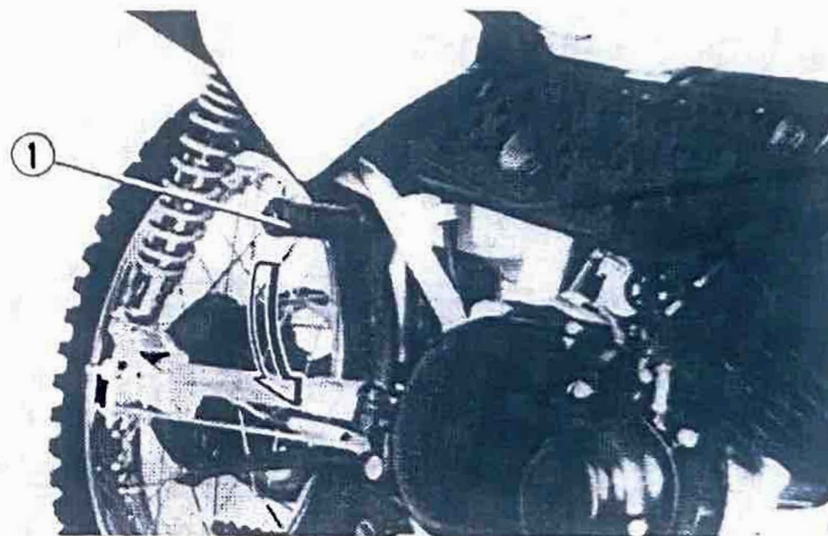

- 1. Kick starter
- EAC41100

Seat

To open the seat, turn the knob as shown.

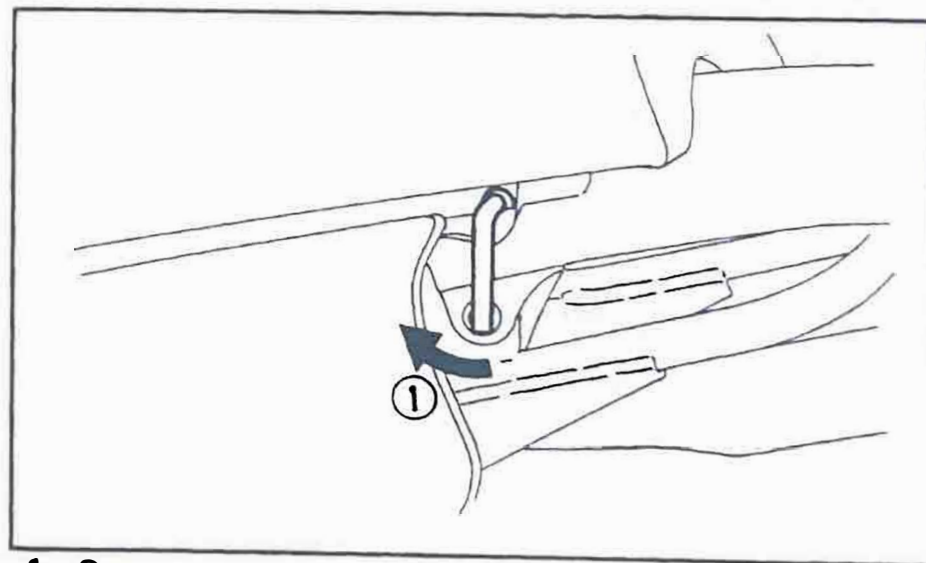

- 5-4 1. Open

To lock the seat, install the seat in its original position.

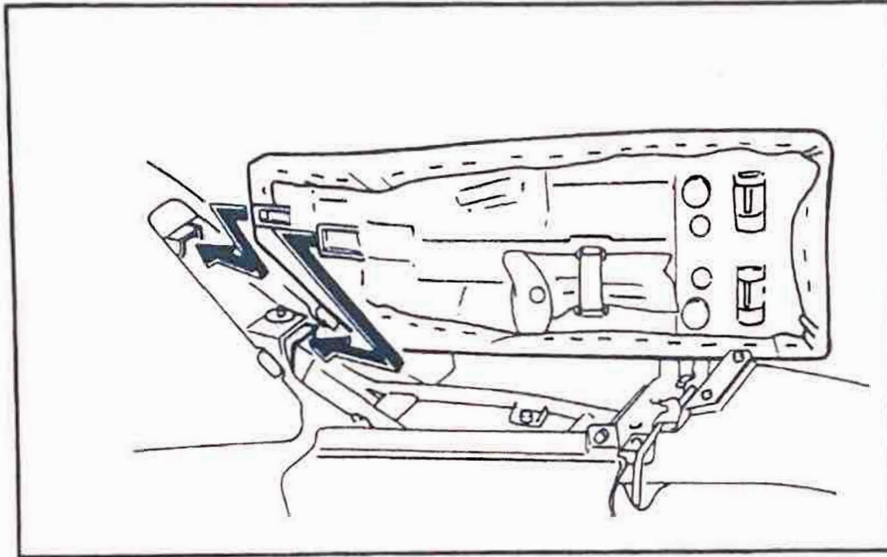

U-017

NOTE: _____

Make sure that the seat is securely fitted.

C-707

Side cover removal

Remove the seat and screw. Then remove the side cover by pulling out the knobs.

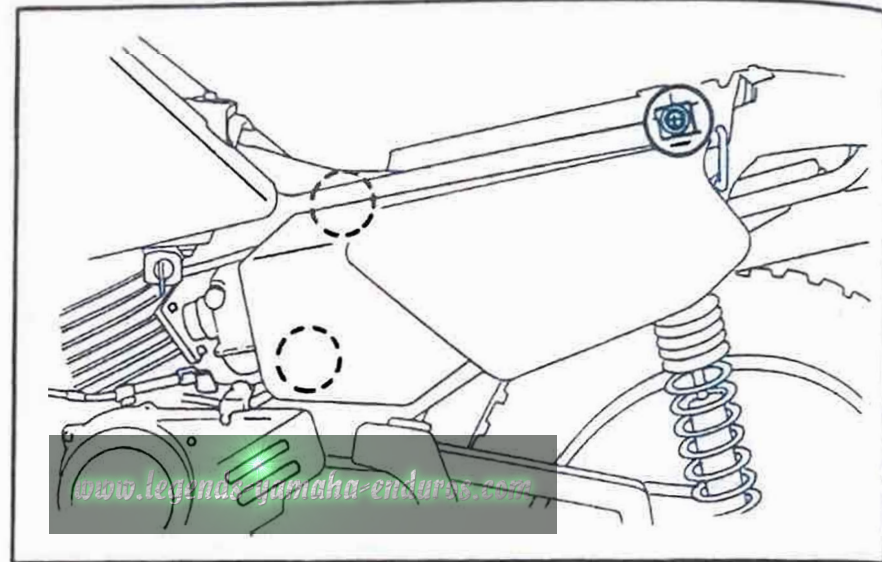

C-902

Rear shock absorber

The spring preload of the rear shock absorber can be adjusted to suit machine's load (ex: optional accessories etc.) and riding conditions. Refer to page 8-22 for proper adjustment procedures.

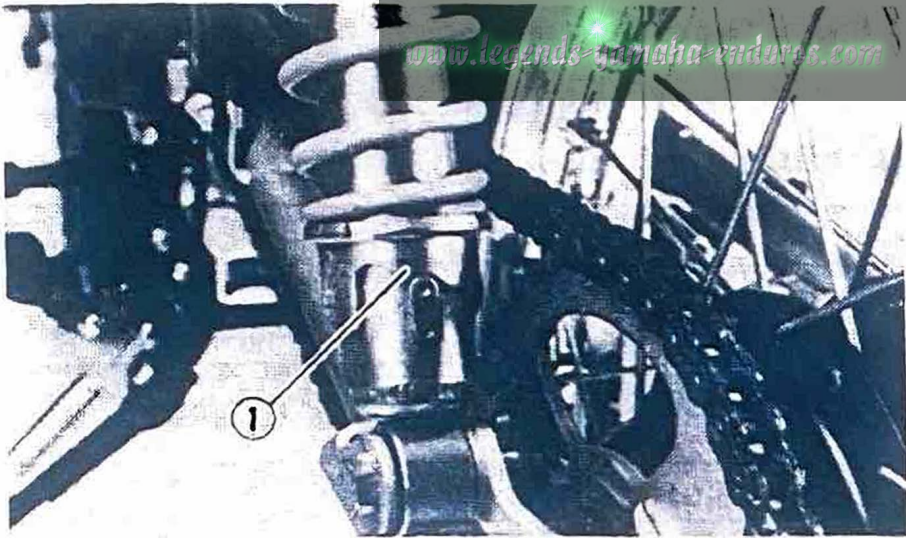

1. Adjuster

PRE-OPERATION CHECKS

Before using this machine, check the following points:

Item	Routine	Page
Front and rear brakes	Check operation, condition and free play. Adjust if necessary.	6-3, 8-14~8-15
Clutch	Check operation, condition and free play. Adjust if necessary.	6-3, 8-16
Throttle grip/Housing	Check for smooth operation. Lubricate/Adjust if necessary.	6-3, 8-13, 8-20
Autolube tank	Check oil level/top-up as required.	6-3~6-4
Transmission oil	Check oil level/top-up as required.	6-4, 8-8~8-10
Drive chain	Check chain slack and condition. Adjust if necessary.	6-4, 8-17~8-19
Wheels/Tires	Check tire pressure, wear, damage.	6-5~6-7, 8-24~8-27
Control cables	Check for smooth operation. Lubricate if necessary.	8-20
Brake and shift pedal shafts	Check for smooth operation. Lubricate if necessary.	8-21
Brake and clutch lever pivots	Check for smooth operation. Lubricate if necessary.	8-21
Sidestand pivot	Check for smooth operation. Lubricate if necessary.	8-21
Fittings/fasteners	Check all chassis fittings and fasteners. Tighten/Adjust, if necessary.	6-7, 8-7
Fuel tank	Check fuel level/top-up as required.	6-8~6-9

NOTE:

Pre-operation checks should be made each time the machine is used. Such an inspection can be accomplished in a very short time, and the added safety it assures is more than worth the time involved.

⚠ WARNING

1. The engine, exhaust pipe(s), and muffler(s) will be very hot after the engine has been run. Be careful not to touch them or to allow any clothing item to contact them during inspection or repair.
 2. If any item in the PRE-OPERATION CHECK is not working properly, have it inspected and repaired before operating the machine.
-

E-114

Brakes (See page 8-14 for more detail)

1. Brake lever and brake pedal

Check for correct free play in the front brake lever and rear brake pedal. Make sure they are working properly. Check the brakes at low speed shortly after starting out. If the free play is incorrect, adjust it.

2. Check the brake lining.

Refer to page 8-15.

U-021

NOTE:

When this brake service is necessary, ask a Yamaha dealer or other qualified mechanic.

E-200

Clutch (See page 8-16 for more detail)

Check the free play in the clutch lever, and make sure the lever operates properly. If the free play is incorrect, adjust it.

E-300

Throttle grip (See page 8-13 for more detail)

Turn the throttle grip to see if it operates properly, and check the free play. Make sure the grip returns by spring force when released. Ask a Yamaha dealer or other qualified mechanic to make any necessary adjustments.

E-409

Engine oil

Make sure the engine oil is at the specified level. Add oil as necessary.

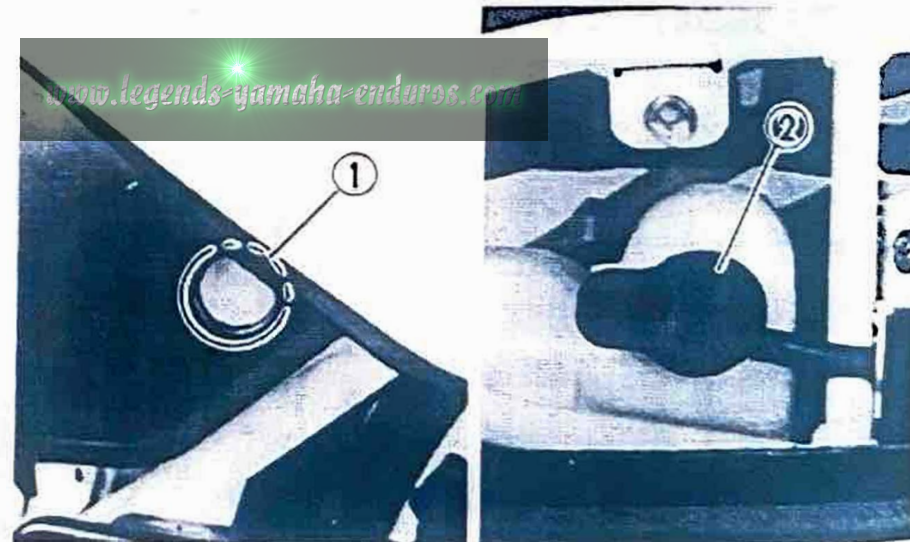

1. Oil level window

2. Oil tank filler cap

Recommended oil:

Yamalube 2-cycle oil or air-cooled
2-stroke engine oil.

Oil quantity:

Total amount

1.0 L (0.88 Imp qt, 1.06 US qt)

U-042

NOTE: _____

Be sure to push the cap into the filler neck
until it is properly seated.

E-404

**Transmission oil (See page 8-8 for more
detail)**

Make sure the transmission oil is at the spe-
cified level. Add oil as necessary.

Recommended oil:

Yamalube 4 (10W30) or
SAE 10W30 type SE motor oil

Oil quantity:

Total amount:

0.7 L (0.62 Imp qt, 0.74 US qt)

Periodic oil change:

0.65 L (0.57 Imp qt, 0.69 US qt)

E-500

Chain (See page 8-17 for more detail)

Check the general condition of the chain and
check the chain slack before every ride. Lu-
bricate and adjust the chain as necessary.

Tires

To ensure maximum performance, long service, and safe operation, note the following:

1. Tire air pressure

Always check and adjust the tire pressure before operating the machine.

! WARNING

Tire inflation pressure should be checked and adjusted when the temperature of the tire equals the ambient air temperature.

Operating tire pressure:

Set pressure with tires cold.

	Front	Rear
Off-road riding	125 kPa (1.25 kgf/cm ² , 18 psi)	125 kPa (1.25 kgf/cm ² , 18 psi)

2. Tire inspection

Always check the tires before operating the machine. If center tread depth reaches the limit as shown, if the tire has a nail or glass fragments in it, or if the side wall is cracked, contact a Yamaha dealer or other qualified mechanic immediately and have the tire replaced.

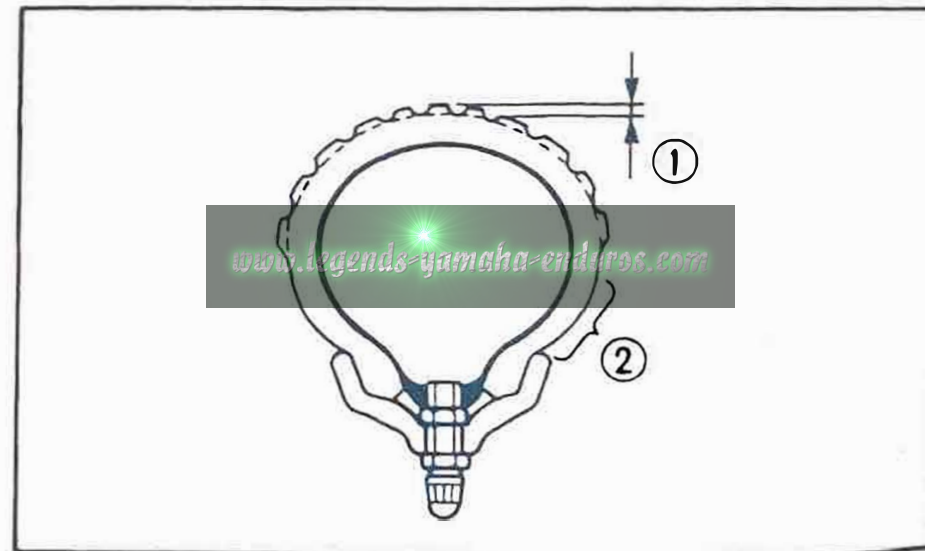

1. Tread depth

2. Side wall

FRONT:

Manufacture	Size	Type
CHENG SING	2.50-18 4PR	KNOBBY

REAR:

Manufacture	Size	Type
CHENG SING	3.00-16 4PR	KNOBBY

Minimum tire tread depth (front and rear)	4.5 mm (0.18 in)
---	------------------

U-684

⚠ WARNING

1. Operating the machine with excessively worn tires decrease riding stability and can lead to loss of control.

Have excessively worn tires replaced by a Yamaha dealer immediately.

Brakes, tires, and related wheel parts replacement should be left to a Yamaha Service Technician or other qualified mechanic.

2. Patching a punctured tube is not recommended. If it is absolutely necessary to do so, use great care and replace the tube as soon as possible with a good quality replacement.

E-933

Wheels

To ensure maximum performance, long service, and safe operation, note the following:

1. Always inspect the wheels before a ride. Check for cracks, bends, or warpage of the wheel; be sure the spokes are tight and undamaged. If any abnormal condition exists in a wheel, consult a Yamaha dealer or other qualified mechanic. Do not attempt even small repairs to the wheel. If a wheel is deformed or cracked, it must be replaced.

2. Tires and wheels should be balanced whenever either one is changed or replaced. Failure to have a wheel balanced can result in poor performance, adverse handling characteristics, and shortened tire life.
3. After installing a tire, ride conservatively to allow the tire to seat itself on the rim properly. Failure to allow proper seating may cause tire failure, resulting in damage to the machine and injury to the rider.

E-939

Accessories or replacement parts

U-697

WARNING

This machine is not designed to pull a trailer or to be attached to a sidecar. The accessories or replacement parts you choose for your machine should be designed specifically for it, and they

must be securely mounted to maintain the inherent stability of the original design. Genuine Yamaha Parts and Accessories are designed and tested to be compatible with your machine. Please consider Genuine Yamaha Parts and Accessories before making an accessory purchase. Use of non-Yamaha-approved parts or accessories may cause loss of handling stability and riding safety. Since Yamaha cannot control the quality of parts or accessories manufactured by other companies, Yamaha cannot be held liable for any consequence caused by the use of items which have not been approved by Yamaha.

E-850

Fittings/Fasteners

Always check the tightness of chassis fittings and fasteners before a ride. Use the chart on page 8-7 to find the correct torque.

E-800

Fuel

Make sure there is sufficient fuel in the tank.

U-610

! WARNING

Do not overfill the fuel tank. Avoid spilling fuel on the hot engine. Do not fill the fuel tank above the bottom of the filler tube as shown in the illustration or it may overflow when the fuel heats up later and expands.

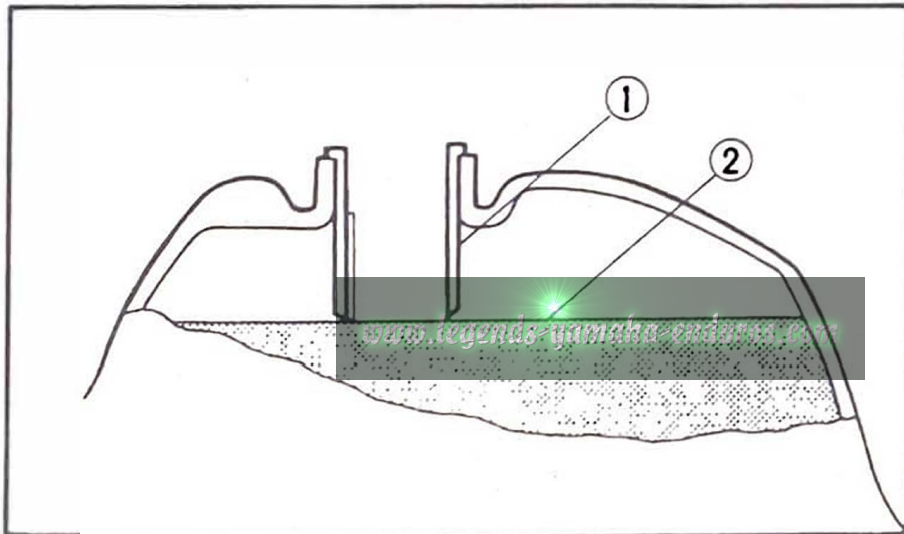

1. Filler tube

2. Fuel level

U-393

CAUTION:

Always wipe off the spilled fuel immediately with a dry and clean soft cloth etc. Fuel containing alcohol may erode painted surfaces or plastic parts.

E-807

Recommended fuel: UNLEADED FUEL

Fuel tank capacity:

Total:

5.0 L (4.4 Imp gal, 5.3 US gal)

Reserve:

1.5 L (1.3 Imp gal, 1.6 US gal)

Your Yamaha engine has been designed to use regular unleaded gasoline with a pump octane number ($(R+M)/2$) of 86 or higher, or research octane number of 91 or higher. If knocking or pinging occurs, use a different brand of gasoline or premium unleaded fuel. Unleaded fuel will give you longer spark plug life and reduced maintenance cost. If unleaded gasoline is not available, then leaded regular gasoline can be used.

Gasohol

There are two types of gasohol; gasohol containing ethanol and that containing methanol. Gasohol containing ethanol can be used if ethanol content does not exceed 10%. Gasohol containing methanol is not recommended by Yamaha because it may cause fuel system damage or vehicle performance problems.

Fuel tank breather hose

This model is equipped with the fuel tank breather hose. Before using this machine be sure to check the following:

1. Check hose connection.
2. Check hose for cracks or damage. Replace if damaged.
3. Make sure the bottom hose is not blocked. Clean it if necessary.

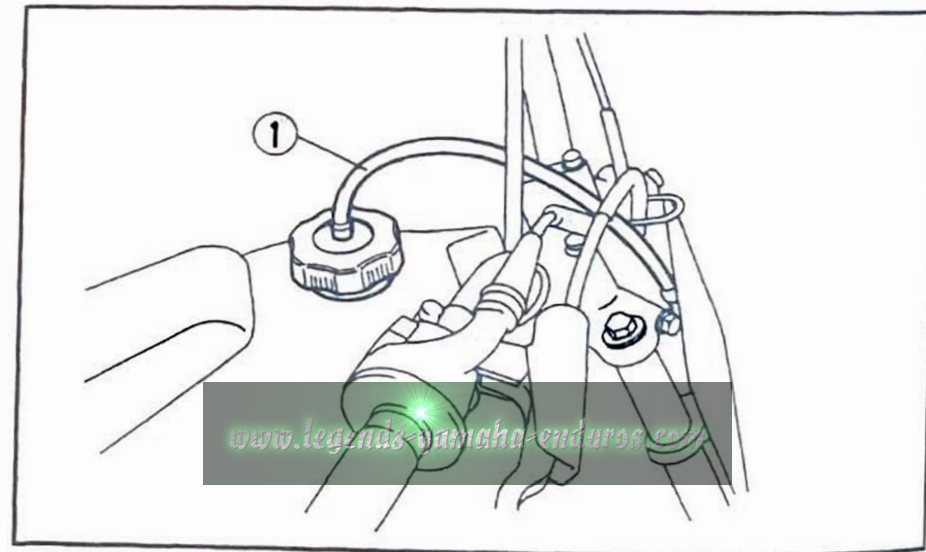

1. Fuel tank breather hose

OPERATION AND IMPORTANT RIDING POINTS

U-722

! WARNING

This model is designed for off-road use only. In most instances, it is illegal to ride this model (either day or night) on any public street or highway.

U-628

! WARNING

1. Never start your engine or let it run for any length of time in a closed area. The exhaust fumes are poisonous and can cause loss of consciousness and death within a short time. Always operate your machine in an area with adequate ventilation.

2. Before starting out, always be sure the sidestand is up. Failure to retract the sidestand completely can result in a serious accident when you try to turn a corner.

F-129

Starting and warming up a cold engine

1. Turn the fuel cock to "ON."
2. Shift transmission into neutral.
3. Operate the starter (CHOKE), and completely close the throttle grip.
4. Kick the kick starter to start the engine.
5. After starting the engine, turn back the starter knob (CHOKE) to warming up position (about halfway).

U-026

NOTE:

To get maximum engine life, always warm up the engine before starting-off. Never accelerate hard with a cold engine!

6. After warming up the engine, turn off the starter knob by pushing it back completely.

U-027

NOTE: _____

The engine is warm when it responds to the throttle normally with the starter turned off.

F-108

Starting a warm engine

The starter (CHOKE) is not required when the engine is warm.

U-314

CAUTION: _____

See "Break-in section" prior to operating the machine for the first time.

F-200

Shifting

The transmission lets you control the amount of power you have available at a given speed for starting, accelerating, climbing hills, etc. The use of the shift pedal is shown in the illustration. (Page 5-2)

To shift into NEUTRAL, depress the shift pedal repeatedly until it reaches the end of its travel (you will feel a stop when you are in first gear) then raise the pedal slightly.

U-315

CAUTION: _____

1. Do not coast for long periods with the engine off, and do not tow the machine a long distance. Even with gears in neutral, the transmission is only properly lubricated when the engine is running. Inadequate lubrication may damage the transmission.

2. Always use the clutch when changing gears. The engine, transmission, and driveline are not designed to withstand the shock of forced shifting and can be damaged by shifting without the clutch.
-

To start out and accelerate:

1. Pull the clutch lever to disengage the clutch.
2. Shift into FIRST gear.
3. Open the throttle gradually, and at the same time, release the clutch lever slowly.
4. Once the machine has reached a high enough speed for you to shift to the next gear, close the throttle, and at the same time, quickly pull in the clutch lever.
5. Shift into SECOND gear. (Be careful not to shift into NEUTRAL.)

6. Open the throttle part way and gradually release the clutch lever.
7. Follow the same procedure when shifting to the next higher gear.

F-203

To decelerate:

1. Close the throttle, and apply the Front and/or rear brakes to slow the machine.
2. Downshift through the gears as road speed decreases.
Any time the engine is about to stall or runs very roughly, pull in the clutch and use the brakes to stop.
3. When the machine is almost completely stopped, shift into NEUTRAL.

Engine break-in

There is never a more important period in the life of your machine than the period between zero and 20 hours of riding. For this reason we ask that you carefully read the following material. Because the engine is brand new, you must not put an excessive load on it for the first several hours of running. The various parts in the engine wear and polish themselves to the correct operating clearances. During this period, prolonged full throttle operation or any condition which might result in excessive heating of the engine must be avoided. However, momentary full throttle operation under load (2 ~ 3 seconds maximum), does not harm the engine. Each full throttle acceleration sequence should be followed with a substantial rest period for the engine by cruising at lower r.p.m.s. so the engine can rid itself of the temporary build up of heat.

1. 0~10 hours:
Avoid continuous operation above half throttle. Stop the engine and let it cool for 5 to 10 minutes after every hour of operation. Vary the speed of the machine from time to time. Do not operate it at one set throttle position.
2. 10~20 hours:
Avoid prolonged operation above 3/4 throttle. Rev the machine freely through the gears, but do not use full throttle at any time.
3. After break-in
Avoid prolonged full-throttle operation. Vary speed occasionally.

EUU35600

CAUTION:

If any engine trouble should occur during the break-in period, consult a Yamaha dealer or other qualified mechanic immediately.

Parking

When parking the machine, stop the engine. Turn the fuel cock to "OFF" whenever stopping the engine.

U-630

WARNING

The muffler and exhaust pipe are hot. Park the machine in a place where pedestrians or children are not likely to touch the machine.

Do not park the machine on a slope or soft ground; the machine may overturn.

H-000

PERIODIC MAINTENANCE AND MINOR REPAIR

H-001

Periodic inspection, adjustment, and lubrication will keep your machine in the safest and most efficient condition possible. Safety is an obligation of the machine owner.

The most important points of machine inspection, adjustment, and lubrication are explained in the following pages.

“Maintenance, replacement, or repair of the emission control devices and systems may be performed by any repair establishment or individual using any part which is certified (if applicable).”

U-631

WARNING

If you are not familiar with machine service, this work should be done by a Yamaha dealer or other qualified mechanic.

H-100

Tool kit

The service information included in this manual is intended to provide you, the owner, with the necessary information for completing some of your own preventive maintenance and minor repairs. The tools provided in the owner's tool kit are sufficient for most of these purposes; however a torque wrench is also necessary to properly tighten nuts and bolts.

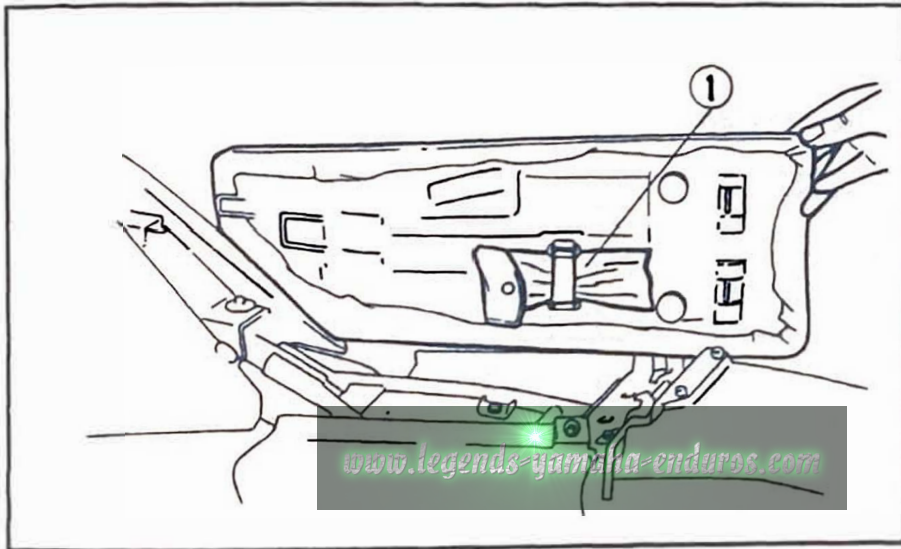

1. Tool kit

U-037

NOTE: _____

If you do not have a torque wrench available during a service operation requiring one, take your machine to a Yamaha dealer or other qualified mechanic to check the torque settings and adjust them as necessary.

U-633

! WARNING _____

Modifications to this machine not approved by Yamaha may cause loss of performance, excessive emissions, and render it unsafe for use. Consult a Yamaha dealer or other qualified mechanic before attempting any changes.

PERIODIC MAINTENANCE/LUBRICATION

ITEM	REMARKS	BRAK-IN 1 month	EVERY	
			6 months	12 months
Spark plug	Check condition. Clean or replace if necessary.	○	○	○
Air filter	Clean. Replace if necessary.		○	○
Carburetor*	Check idle speed/starter operation. Adjust if necessary.	○	○	○
Fuel line*	Check fuel hose for cracks or damage. Replace if necessary.		○	○
Transmission oil*	Check oil level/oil leakage. Correct if necessary. Replace every 24 months. (Warm engine before draining.)	REPLACE	○	○
Autolube pump*	Check operation. Correct if necessary. Air bleeding	○	○	○
Brake	Check operation. Adjust if necessary.		○	○
Clutch*	Check operation. Adjust if necessary.		○	○
Rear arm pivot*	Check rear arm assembly for looseness. Correct if necessary. Moderately repack every 24 months.**	○		○
Wheels*	Check balance/damage/runout/spoke tightness. Repair if necessary.		○	○
Wheel bearings*	Check bearings assembly for looseness/damage. Replace if damaged.		○	○
Steering bearing*	Check bearings assembly for looseness. Correct if necessary. Moderately repack every 24 months.**	○		○
Front forks*	Check operation/oil leakage. Repair if necessary.		○	○
Rear shock absorber*	Check operation/oil leakage. Repair if necessary.		○	○

ITEM	REMARKS	BRAK-IN 1 month	EVERY	
			6 months	12 months
Drive chain	Check chain slack/alignment. Adjust if necessary. Clean and lube.	Every Ride (More often in wet or dusty areas)		
Fittings/Fasteners*	Check all chassis fittings and fasteners. Correct if necessary.	○	○	○
Sidestand*	Check operation. Repair if necessary.	○	○	○

*: It is recommended that these items be serviced by a Yamaha dealer or other qualified mechanic.

** : Medium weight wheel bearing grease.

Spark plug inspection

The spark plug is an important engine component and is easy to inspect. The condition of the spark plug can indicate something of the condition of the engine.

The ideal color on the white porcelain insulator around the center electrode is a medium to light tan color for a machine that is being ridden normally. Do not attempt to diagnose any problems yourself. Instead, take the machine to a Yamaha dealer or other qualified mechanic. You should periodically remove and inspect the spark plug because heat and deposits will cause the spark plug to slowly break down and erode. If electrode erosion becomes excessive, or if carbon and other deposits are excessive, you should replace the spark plug with a proper type plug.

Standard spark plug:
B7ES (NGK)

Before installing the spark plug, measure the electrode gap with a wire thickness gauge; adjust the gap to specification as necessary.

Spark plug gap:

0.5 ~ 0.6 mm (0.020 ~ 0.024 in)

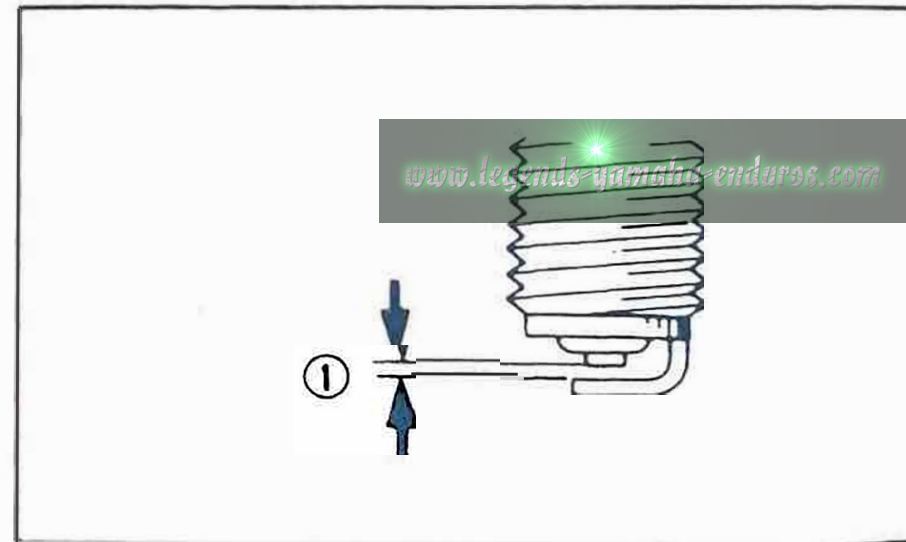

1. Spark plug gap

When installing the plug, always clean the gasket surface and use a new gasket. Wipe off any grime from the threads, and torque the spark plug properly.

Spark plug torque:
25 Nm (2.5 m·kg, 18 ft·lb)

U-038

NOTE: _____

If a torque wrench is not available when you are installing a spark plug, a good estimate of the correct torque is 1/4 to 1/2 turns past finger tight. Have the spark plug torqued to the correct value as soon as possible with a torque wrench.

Torque specifications

(For a more complete list, refer to the Service Manual for this model.)

Use a torque wrench to tighten these items. It is recommended that these items be checked regularly.

Always check the tightness of these items whenever they are loosened for any reason.

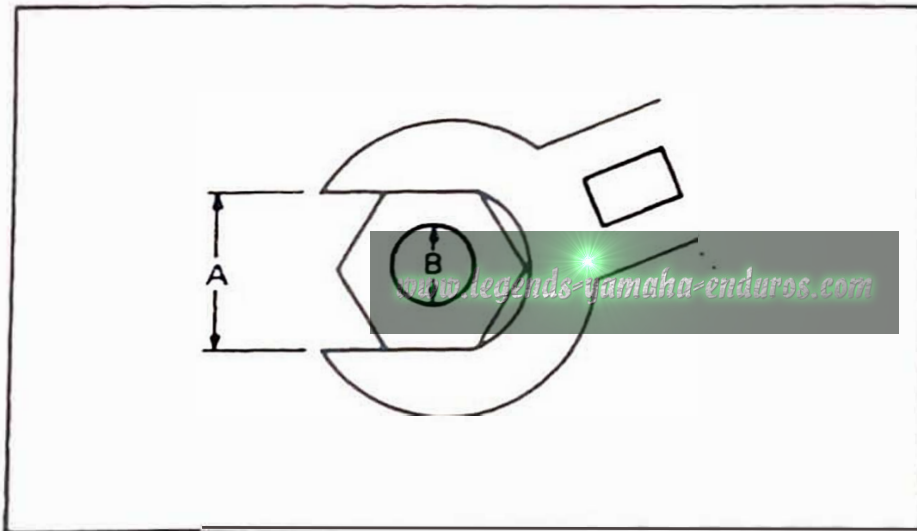

CH3-01

A (Nut)	B (Bolt)	General torque specifications		
		Nm	m·kg	ft·lb
10 mm	6 mm	6	0.6	4.3
12 mm	8 mm	15	1.5	11
14 mm	10 mm	30	3.0	22
17 mm	12 mm	55	5.5	40
19 mm	14 mm	85	8.5	61
22 mm	16 mm	130	13.0	94

Item	Torque		
	Nm	m·kg	ft·lb
Spark plug	25	2.5	18
Engine drain plug	20	2.0	14
Front wheel axle	43	4.3	31
Rear wheel axle	39	3.9	28
Tension bar bolt	18	1.8	13
Sprocket shaft nut	85	8.5	61

Transmission oil level check

1. To check the oil level, the machine must stand **VERTICALLY** with both wheels on the ground. A slight tilt toward the side can produce false readings.
2. When checking the oil level, stop the engine and remove the dipstick. Rest the dipstick on the threads of the hole.

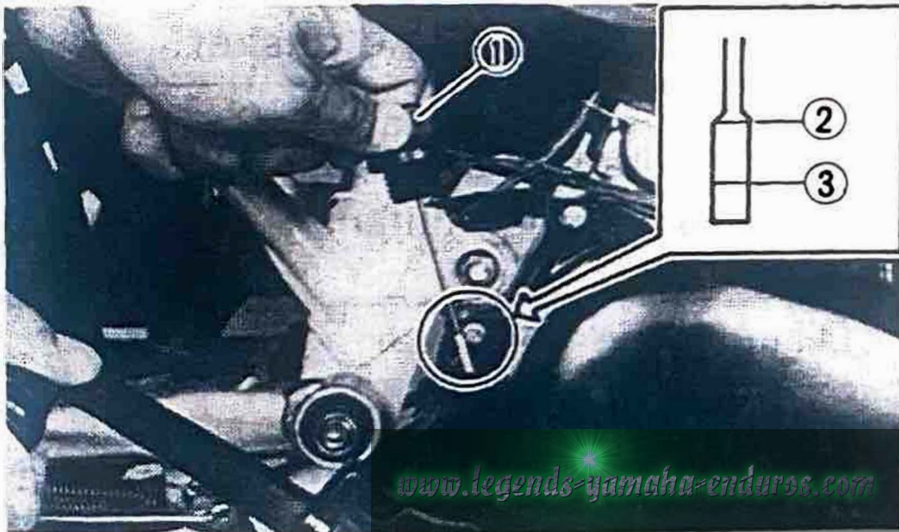

1. Dipstick 2. Maximum level 3. Minimum level

NOTE: _____

When checking engine oil level, let the unscrewed dipstick just rest on the case threads.

3. The dipstick has a minimum and maximum level; the oil level should be between the two. If the level is low add oil to raise it to the proper level.

Recommended oil:

Yamalube 4 (10W30) or
SAE 10W30 type SE motor oil

Oil quantity:

Total amount:

0.7 L (0.62 Imp qt, 0.74 US qt)

Periodic oil change:

0.65 L (0.57 Imp qt, 0.69 US qt)

U-349

CAUTION: _____

Do not add any chemical additives. Transmission oil also lubricates the clutch and additives could cause clutch slippage.

CAUTION:

Be sure no foreign material enters the crankcase.

Transmission oil replacement

1. To drain the oil, warm up the engine for several minutes.
2. Place an oil pan under the engine.
3. Remove the drain plug and drain the oil.

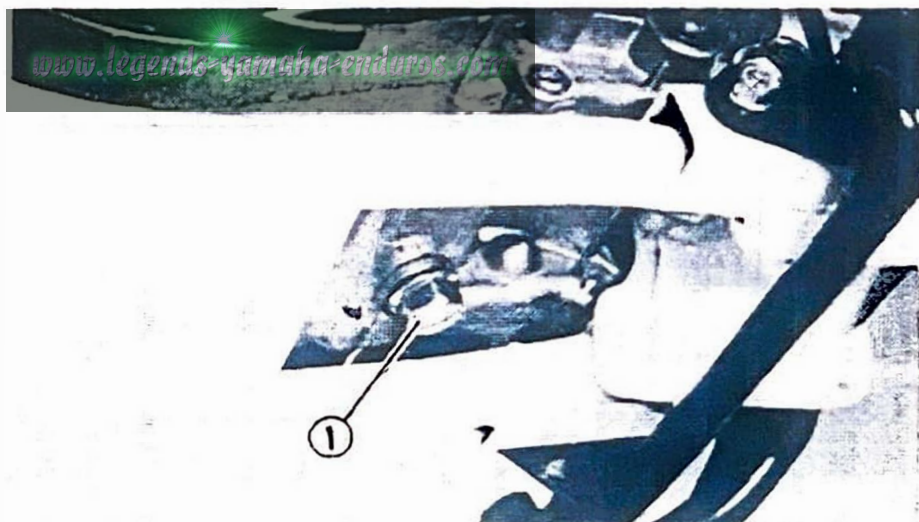

1. Drain plug

4. Reinstall the drain plug (make sure it is tight).

Drain plug torque:
20 Nm (2.0 m·kg, 14 ft·lb)

CAUTION:

Before reinstalling the drain plug, do not forget to install the gasket.

5. Add oil through the dipstick hole. Install the dipstick and tighten.

Oil capacity:
Total amount:
0.7 L (0.62 Imp qt, 0.74 US qt)
Periodic oil change:
0.65 L (0.57 Imp qt, 0.69 US qt)
Recommended oil:
See page 6-4

CAUTION:

Do not allow foreign material to enter the engine.

6. Start the engine and allow a few minutes of warm-up.
While warming up, check for oil leakage.

CAUTION:

If oil leaks, stop the engine immediately, and check for the cause.

7. Stop the engine and check the oil level.

Air filter

1. Remove the seat.
2. Remove the left side cover.
3. Remove the air filter case cover by removing the screw.

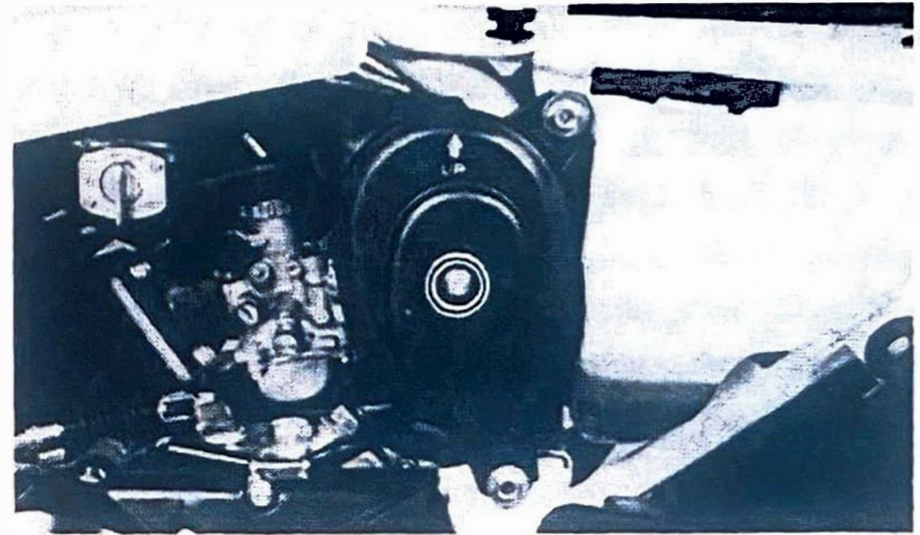

4. Pull out the element and clean it with solvent.

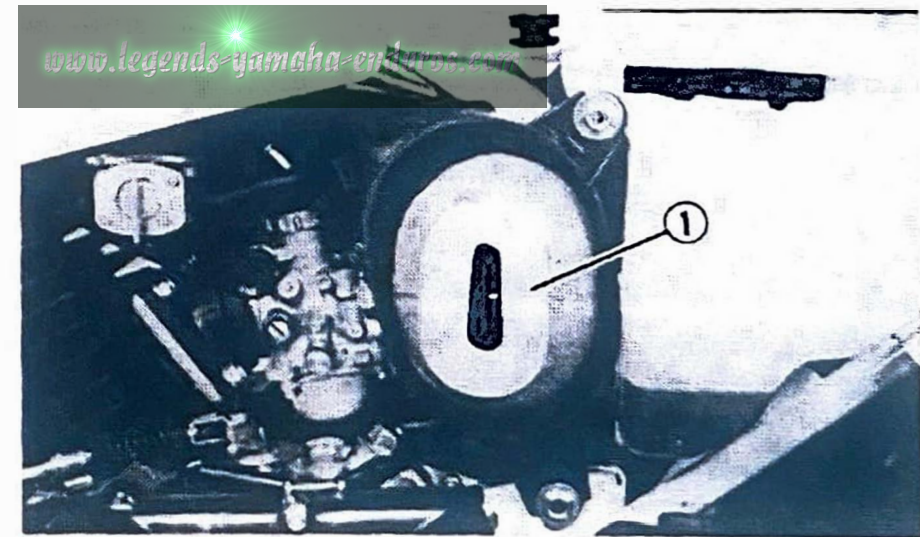

1. Air filter element

5. Apply recommended oil to the entire surface of the filter and squeeze out the excess oil. The element should be wet but not dripping.

Recommended oil:
Yamaha foam air filter oil or
other quality air filter oil

NOTE: _____
If foam air filter oil is not available, engine
oil may be used.

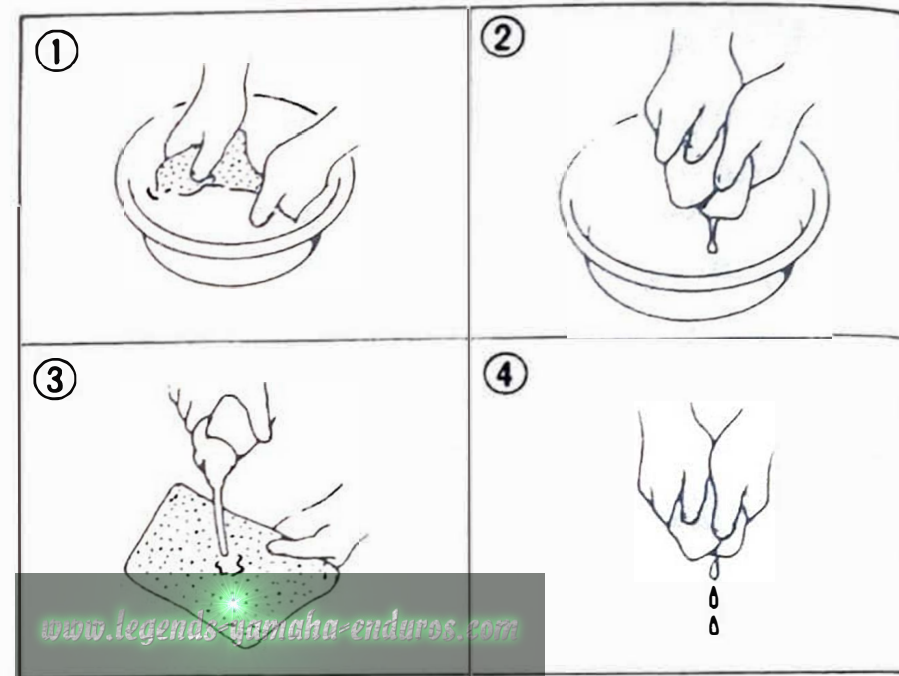

6. When installing the element in its case, be sure its sealing surface matches the sealing surface of the case so there is no air leak.
7. The element should be cleaned at the specified intervals. It should be cleaned more often if the machine is operated in dusty or wet areas.

CAUTION:

The engine should never be run without the air cleaner element; excessive piston and/or cylinder wear may result.

Carburetor adjustment

The carburetor is a vital part of the engine and its emission control system. Adjusting should be left to a Yamaha dealer or other qualified mechanic with the professional knowledge, specialized data, and equipment to do so properly.

Idle speed adjustment**NOTE:**

A diagnostic tachometer must be used for this procedure.

1. Start the engine and warm it up for a few minutes (normally, 1 or 2 minutes) at approximately 1,000 to 2,000 r/min. Occasionally rev the engine to 4,000 to 5,000 r/min. The engine is warm when it quickly responds to the throttle.
2. Set the idle to the specified engine speed by adjusting the throttle stop screw; turn the screw in to increase engine speed, and out to decrease engine speed.

Standard idle speed:
1,300 ~ 1,450 r/min

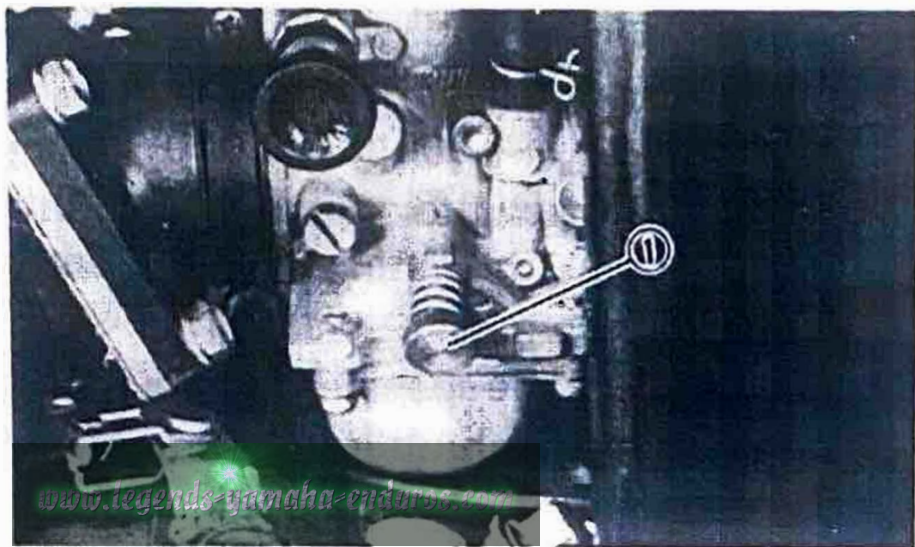

1. Throttle stop screw

EUU11700

NOTE: _____

If the specified idle speed cannot be obtained by performing the above adjustment, consult a Yamaha dealer or other qualified mechanic.

H-903

Throttle cable adjustment

U-064

NOTE: _____

Before adjusting the throttle cable free play, the engine idling speed should be adjusted.

The throttle cable should have a specified free play in the turning direction at the grip flange. If the play is incorrect, take the following steps for adjustment.

Free play:

3~5 mm (0.12~0.20 in)

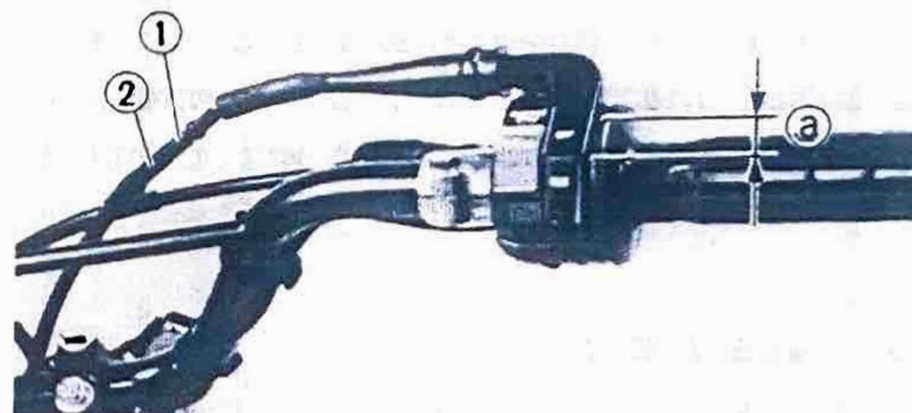

1. Lock nut

2. Adjuster

a. Free play

1. Loosen the lock nut.
2. Turn the adjuster in or out until the adjustment is suitable.
3. Tighten the lock nut.

Front brake adjustment

The front brake should be adjusted to suit the rider's preference; but free play at the brake lever pivot point should be 5 ~ 8 mm (0.2 ~ 0.3 in). Adjustment can be made at one of two places; either the handlebar lever holder or the front brake hub.

1. Loosen the lock nut.

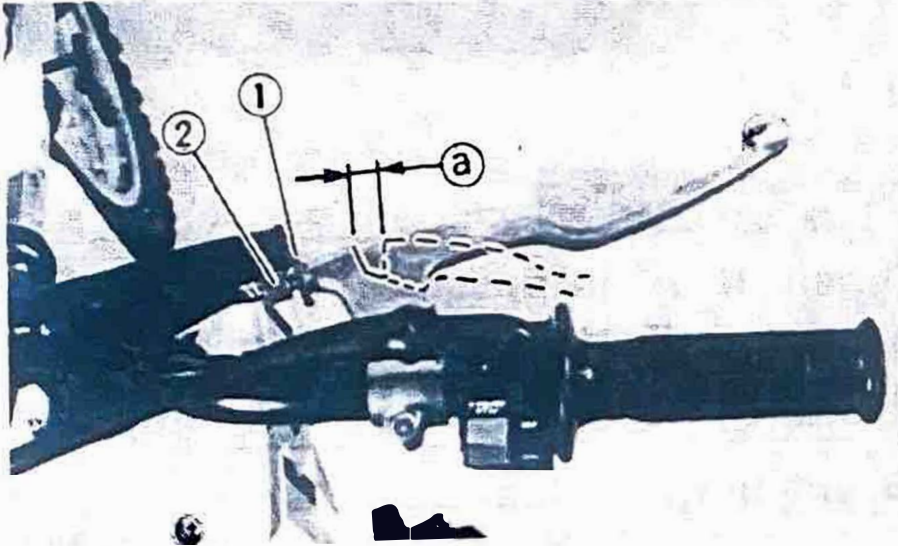

1. Lock nut
 2. Adjuster
- a. 5 ~ 8 mm (0.2 ~ 0.3 in)

2. Turn the cable length adjuster in or out until adjustment is suitable.

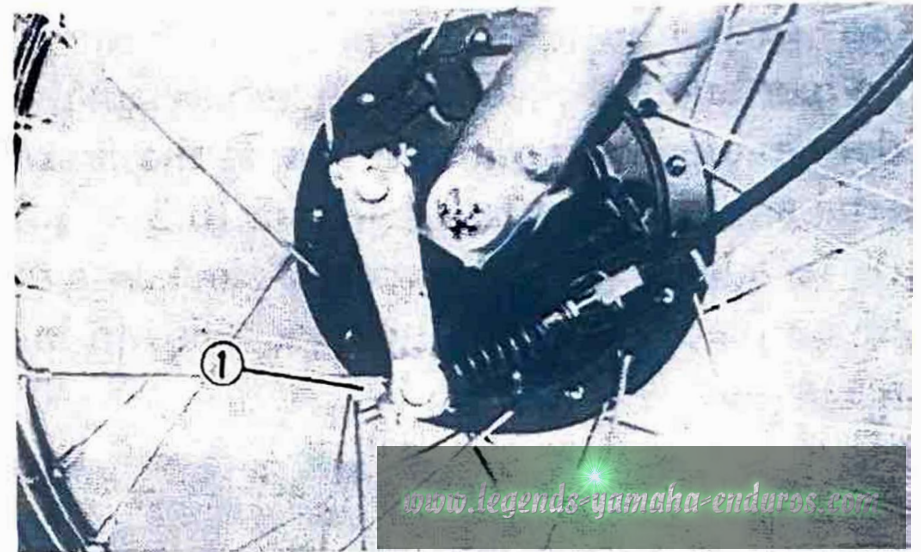

1. Adjuster

3. Tighten the lock nut.

U-731

! WARNING

When it is impossible to make the proper adjustment, ask a Yamaha dealer or other qualified mechanic.

Rear brake adjustment

The rear brake should be adjusted to suit the rider's preference; but free play at the brake pedal end must be 20 ~ 30 mm (0.8 ~ 1.2 in). To adjust, turn the adjuster clockwise to reduce play; turn it counterclockwise to increase play.

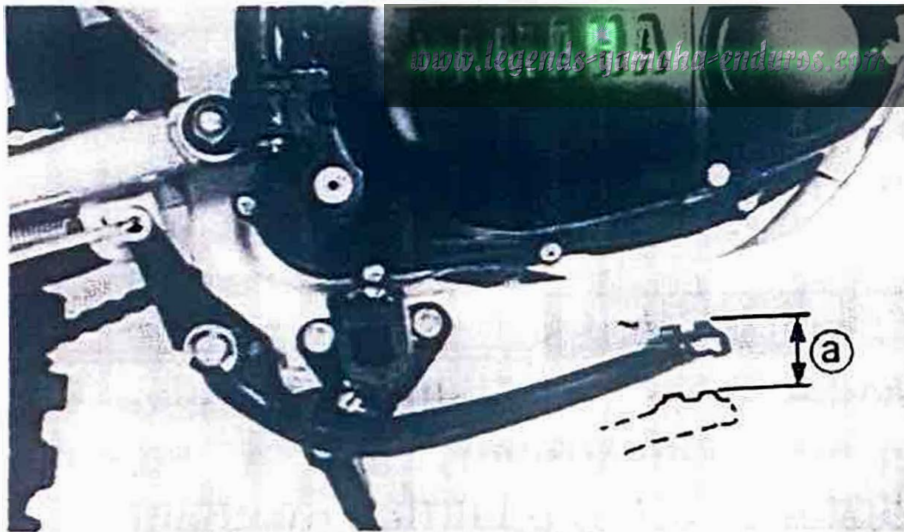

a. Free play 20 ~ 30mm (0.8 ~ 1.2 in)

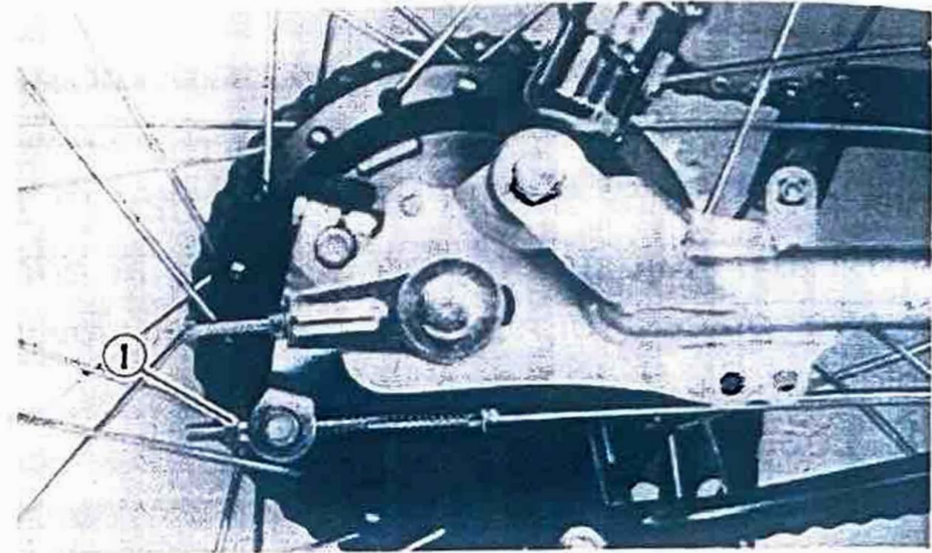

1. Adjuster

EUU73100

! WARNING

When it is impossible to make the proper adjustment, ask a Yamaha dealer or other qualified mechanic.

Brake lining inspection

To specified thickness of the brake lining is 4 mm (0.16 in). The lining should be replaced when it wears to less than 2 mm (0.08 in). If worn out, ask a Yamaha dealer or other qualified mechanic to install a new set.

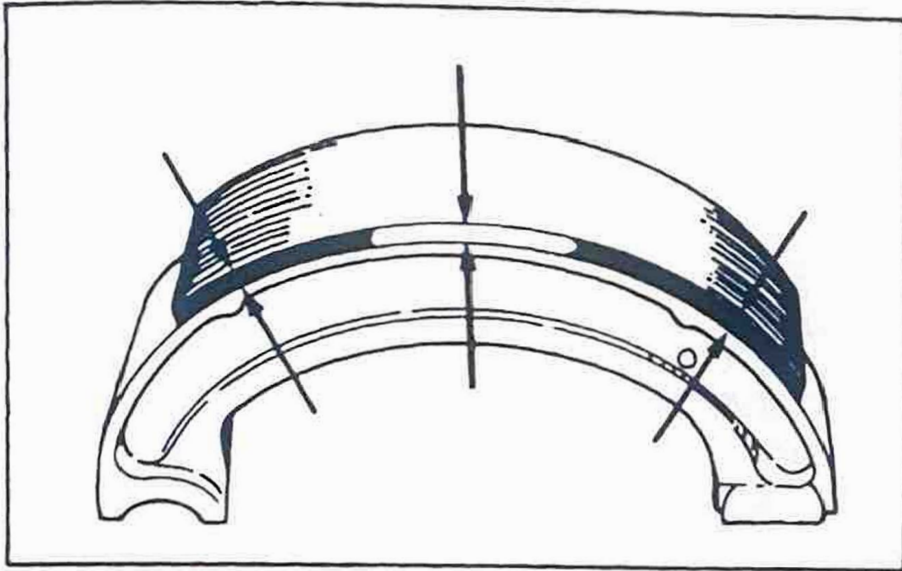

I-009

Clutch adjustment

This model has two clutch cable length adjusters. The cable length adjuster are used to take up slack from cable stretch and to provide sufficient free play for proper clutch operation.

I-005

Free play adjustment

The clutch should be adjusted to suit the rider's preference; but, free play at the lever pivot should be 2 ~ 3 mm (0.08 ~ 0.12 in).

Loosen either the handlebar lever adjuster lock nut or the cable length adjuster lock nut. Turn the cable length adjuster either in or out until proper lever free play is achieved.

Clutch lever free play:

2 ~ 3 mm (0.08 ~ 0.12 in)

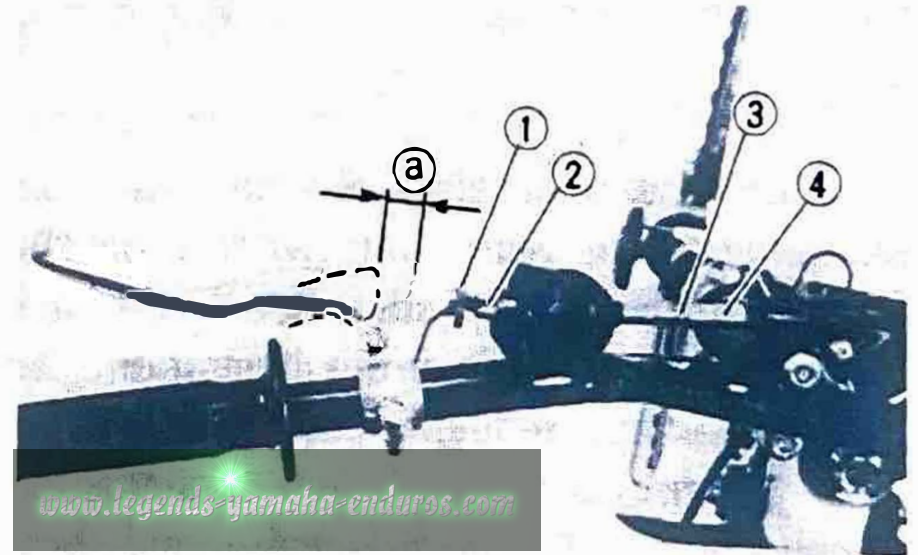

1. Handlebar lever adjuster lock nut
2. Handlebar lever adjuster
3. Cable length adjuster lock nut
4. Cable length adjuster
- a. Clutch lever free play

Drive chain slack check

U-048

NOTE: _____

Before checking and/or adjusting the chain slack, rotate the rear wheel through several revolutions. Check the chain slack several times to find the point where the chain is the tightest. Check and/or adjust the chain slack where the rear wheel is in this "tight chain" position.

To check the chain slack the machine must stand vertically with both wheels on the ground and without a rider. Check the slack at the position shown in the illustration. The normal vertical deflection is approximately 20 ~ 30 mm (0.8 ~ 1.2 in). If the deflection exceeds 30 mm (1.2 in) adjust the chain slack.

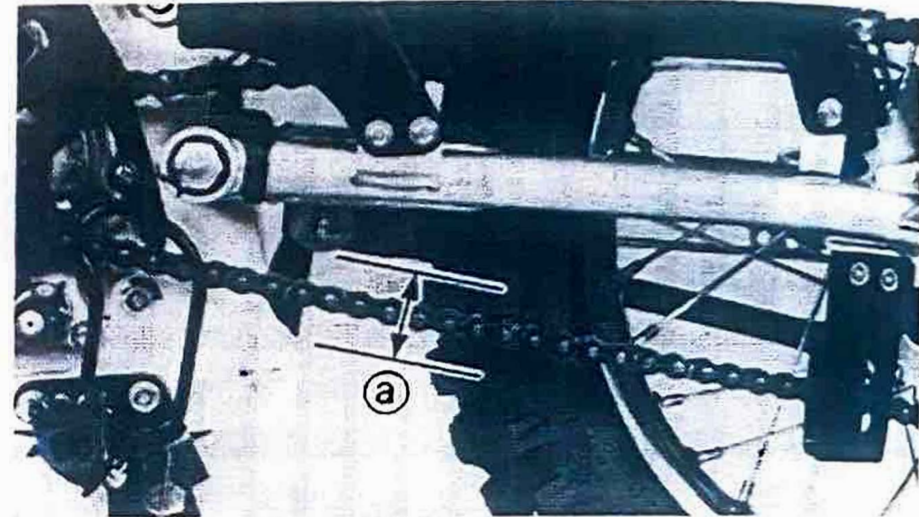

a. 20 ~ 30 mm (0.8 ~ 1.2 in)

I-401

Drive chain slack adjustment

1. Loosen the rear brake adjuster.

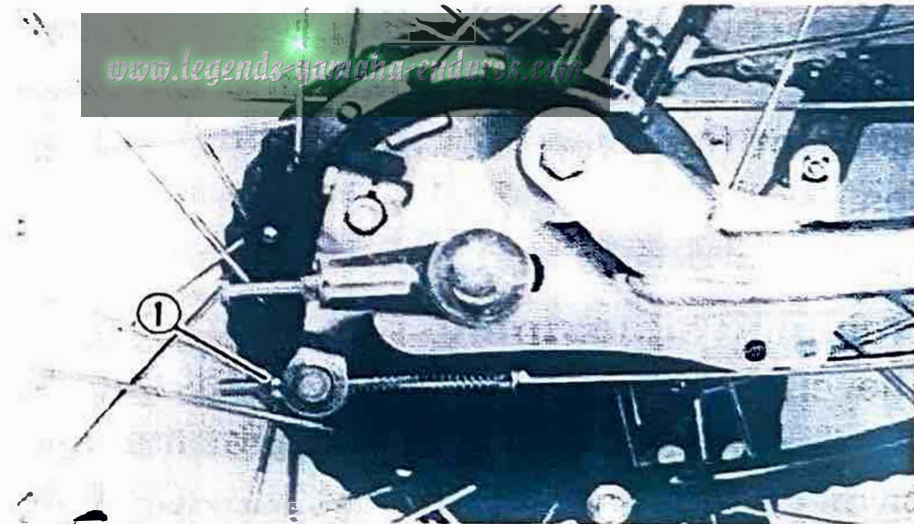

1. Rear brake adjuster

2. Remove the cotter pin from the rear wheel axle nut.
3. Loosen the rear wheel axle nut.
4. Loosen the sprocket shaft nut and lock nuts on each side. To tighten the chain, turn chain adjuster clockwise. To loosen the chain, turn the adjuster counter-clockwise and push the wheel forward. Turn each adjuster exactly the same amount to maintain correct axle alignment.

(There are marks on each side of swingarm and on each chain adjuster; use them to check for proper alignment.)

U-333

CAUTION:

Too small chain slack will overload the engine and other vital parts; keep the slack within the specified limits.

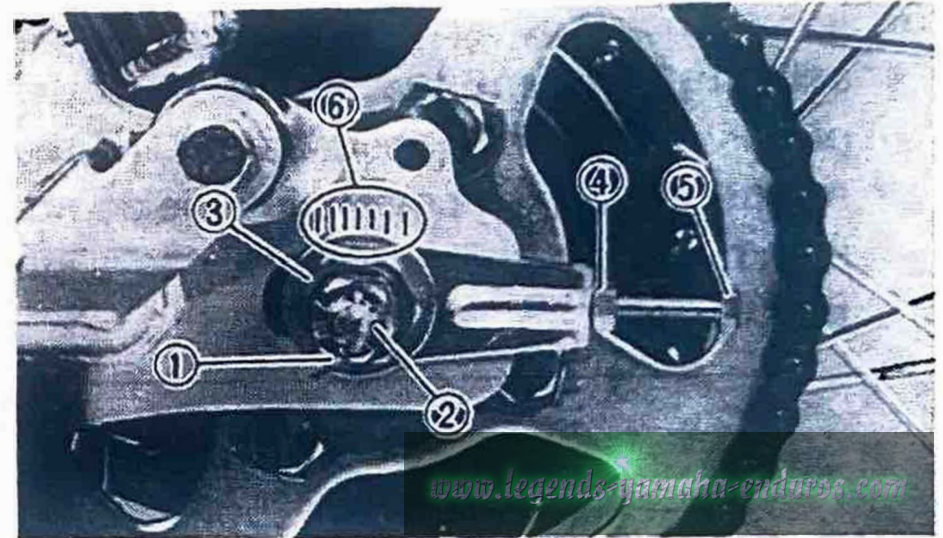

- | | | |
|---------------|-------------|-----------------------|
| 1. Cotter pin | 2. Axle nut | 3. Sprocket shaft nut |
| 4. Lock nut | 5. Adjuster | 6. Marks of alignment |

5. After adjusting, be sure to tighten the lock nuts, sprocket shaft nut and the axle nut.

Tightening torque:

Sprocket shaft nut:

85 Nm (8.5 m·kg, 61 ft·lb)

Axle nut:

39 Nm (3.9 m·kg, 28 ft·lb)

6. Insert a new cotter pin into the rear wheel axle nut and bend the end of the cotter pin as shown in the illustration. (If the nut notch and the cotter pin hole do not match tighten the nut slightly to align them.)

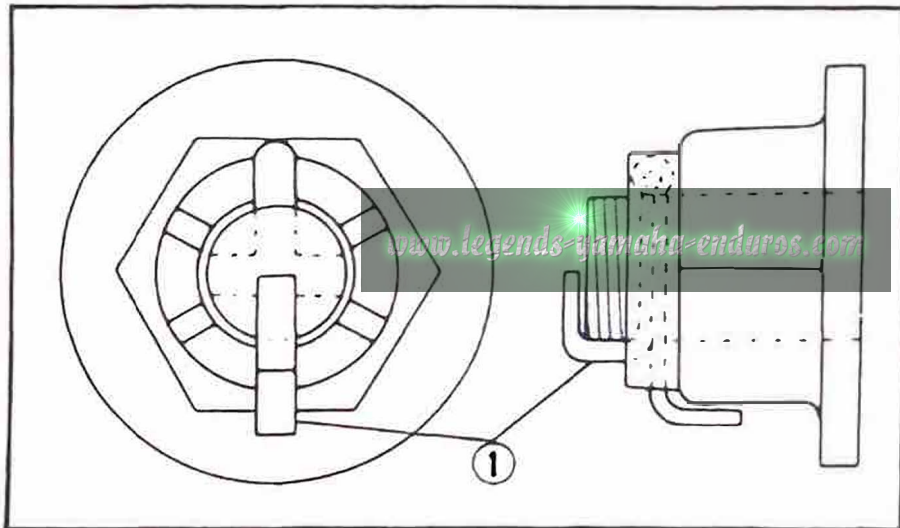

1. Cotter pin

U-647

⚠ WARNING

Always use a new cotter pin on the axle nut.

7. Adjust the free play in the brake pedal.

Drive chain lubrication

The chain consists of many parts which work against each other. If the chain is not maintained properly, it will wear out rapidly, therefore, service the chain regularly. This service is especially necessary when riding in dusty conditions.

1. Use Yamaha Chain and Cable Lube or any brands of spray type chain lubricant. First, remove all dirt and mud from the chain with a brush or cloth, then spray a lubricant between both rows of side plates and on all center rollers. This should be performed every ride.
2. To clean the chain, remove the chain from the machine, dip it in solvent, and clean out as much dirt as possible. Take the chain out of the solvent and dry it. Immediately lubricate the chain to prevent rust.

I-100

Cable inspection and lubrication

U-646

WARNING

Damage to the outer housing of the various cables may cause corrosion and interfere with the movement of the cable. An unsafe condition may result so replace such cables as soon as possible.

Lubricate the inner cable and the cable end. If they do not operate smoothly, ask a Yamaha dealer or other qualified mechanic to replace them.

Recommended lubricant:
Yamaha Chain and Cable Lube or
SAE 10W30 motor oil

I-102

Throttle cable and grip lubrication

The throttle twist grip assembly should be greased at the time that the cable is lubricated, since the grip must be removed to get at the end of the throttle cable. Two screws clamp the throttle housing to the handlebar. Once these two are removed, the end of the cable can be held high to pour in several drops of lubricant. With the throttle grip disassembled, coat the metal surface of the grip assembly with a suitable all-purpose grease.

I-108

Autolube pump adjustment

The Autolube pump is a vital part of the engine and requires very sophisticated adjustment. Most adjusting should be left to a Yamaha dealer who has the professional knowledge and experience to do so.

Brake and shift pedals

Lubricate the pivoting parts.

Recommended lubricant:
Yamaha Chain and Cable Lube or
SAE 10W30 motor oil

I-303

Brake and clutch levers

Lubricate the pivoting parts.

Recommended lubricant:
Yamaha Chain and Cable Lube or
SAE 10W30 motor oil

I-310

Sidestand

Lubricate the pivoting parts. Check to see that the sidestand move up and down smoothly.

Recommended lubricant:
Yamaha Chain and Cable Lube or
SAE 10W30 motor oil

U-701

WARNING

If the sidestand movement is not smooth, consult a Yamaha dealer or other qualified mechanic.

I-313

Rear suspension

Lubricate the pivoting parts.

Recommended lubricant:
Lithium soap base grease

I-205

Front fork inspection

U-657

WARNING

Securely support the machine so there is no danger of it falling over.

1. Visual check

Check any scratch/damage on the inner tube and excessive oil leakage with the front fork.

2. Operation check

Place the machine on a level place.

- a. Hold the machine on an upright position with a rider's hands on the handlebar and apply the front brake.
- b. Pump the front fork up and down for several times.

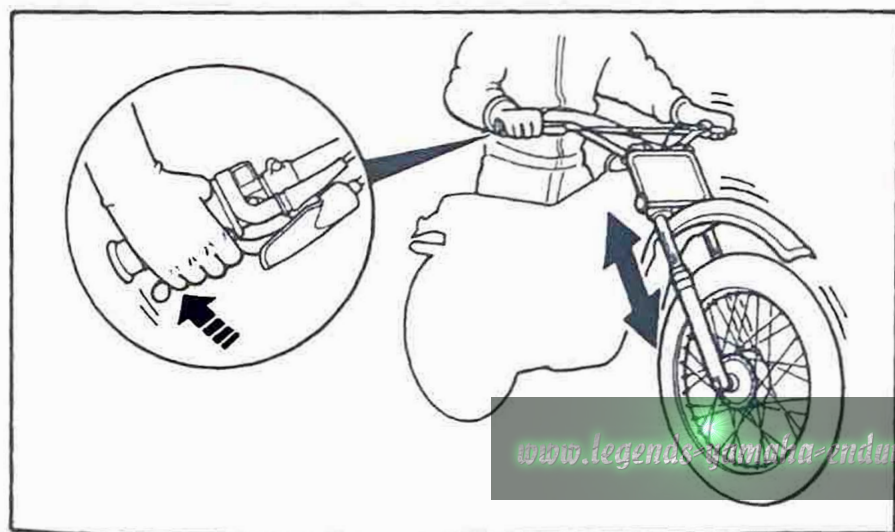

EUU42600

CAUTION:

If any damage or unsmooth movement is found with the front fork, consult a Yamaha dealer or other qualified mechanic.

I-509

Rear shock absorber adjustment

Spring preload

If the spring seat is raised, the spring becomes stiffer, and if lowered, it becomes softer.

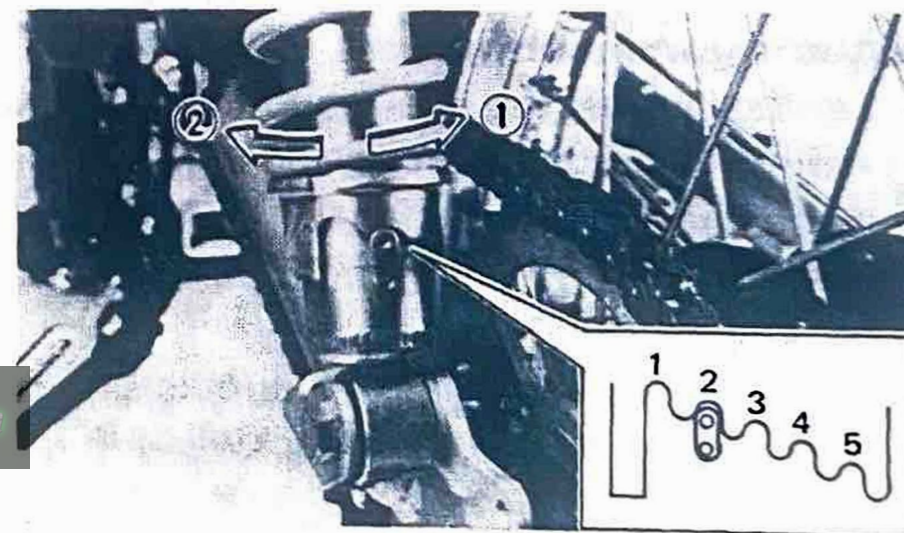

1. Softer

2. Stiffer

Standard position: 2

1. — Softest
5. — Stiffest

U-652

! WARNING

Always adjust each shock absorber to the same setting. Uneven adjustment can cause poor handling and loss of stability.

I-600

Steering inspection

Periodically inspect the condition of the steering. Worn out or loose steering bearings may be dangerous.

Place a block under the engine to raise the front wheel off the ground.

Hold the lower end of the front forks and try to move them forward and backward. If any

free play can be felt, ask a Yamaha dealer or other qualified mechanic to inspect and adjust the steering. Inspection is easier if the front wheel is removed.



U-657

! WARNING

Securely support the machine so there is no danger of it falling over.

Wheel bearings

If the wheel bearings in the front or rear wheel allow play in the wheel hub or if the wheel does not turn smoothly, have a Yamaha dealer or a qualified mechanic inspect the wheel bearings. The wheel bearings should be inspected according to the General Maintenance Schedule.

Front wheel removal

1. Elevate the front wheel by placing a suitable stand under the engine.
2. Remove the brake cable; loosen the cable adjuster and remove the cable from the cam lever at the front brake shoe plate.
3. Remove the cotter pin from the front wheel axle and remove the axle nut.

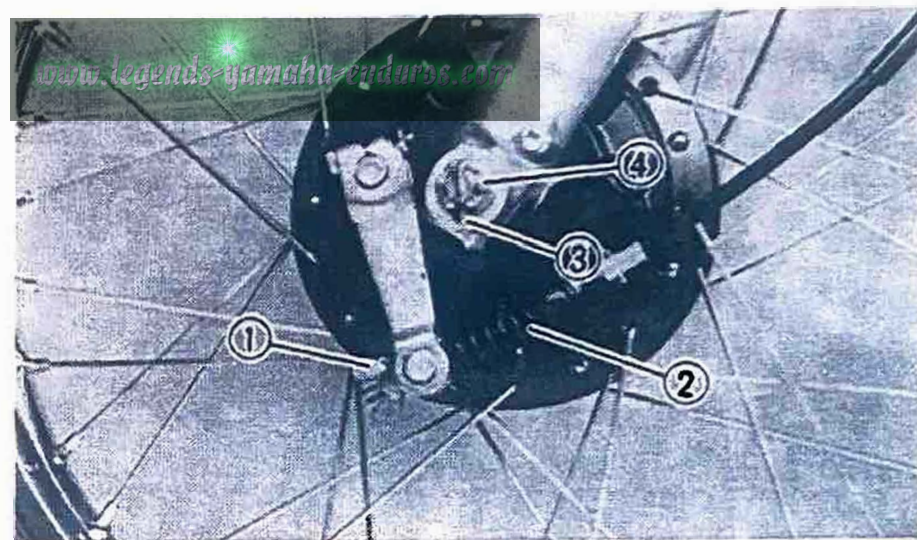

1. Cable adjuster
3. Cotter pin

2. Brake cable
4. Axle nut

4. Turn and pull out the front wheel axle; the wheel assembly can now be removed.

Front wheel installation

When installing the front wheel, reverse the removal procedure.

Pay attention to the following points:

1. Be sure the boss on the outer fork tube correctly engages with the locating slot on the brake shoe plate.

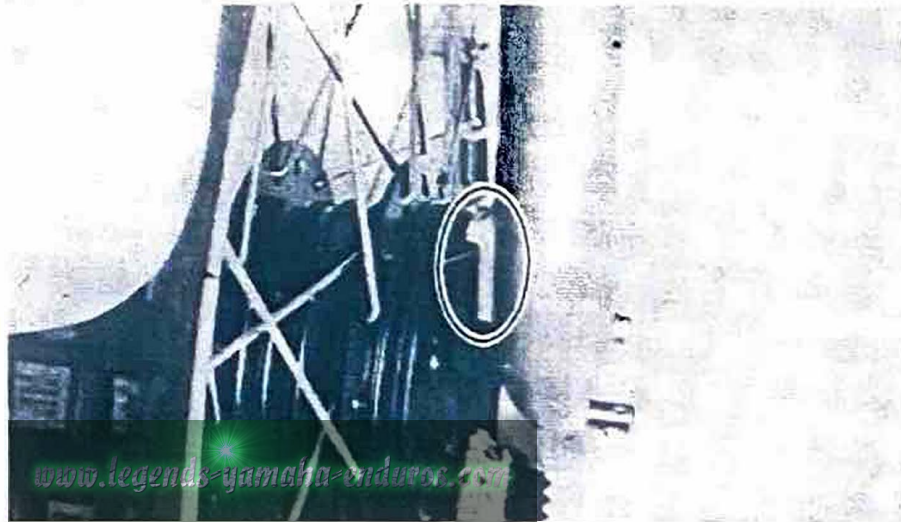

2. Make sure the axle nut is properly torqued, and a new cotter pin is installed.

U-647

! WARNING

Always use a new cotter pin on the axle nut.

Axle nut torque:
43 Nm (4.3 m·kg, 31 ft·lb)

3. Adjust the free play in the brake lever.

J-303

Rear wheel removal

U-661

! WARNING

It is advisable to have a Yamaha dealer or other qualified mechanic service the rear wheel.

1. Elevate the rear wheel by placing a suitable stand under the engine.
2. Remove the tension bar and the brake rod from the brake shoe plate. The tension bar can be removed by removing the cotter pin and nut from the tension bar bolt. The brake rod can be removed by removing the adjuster.

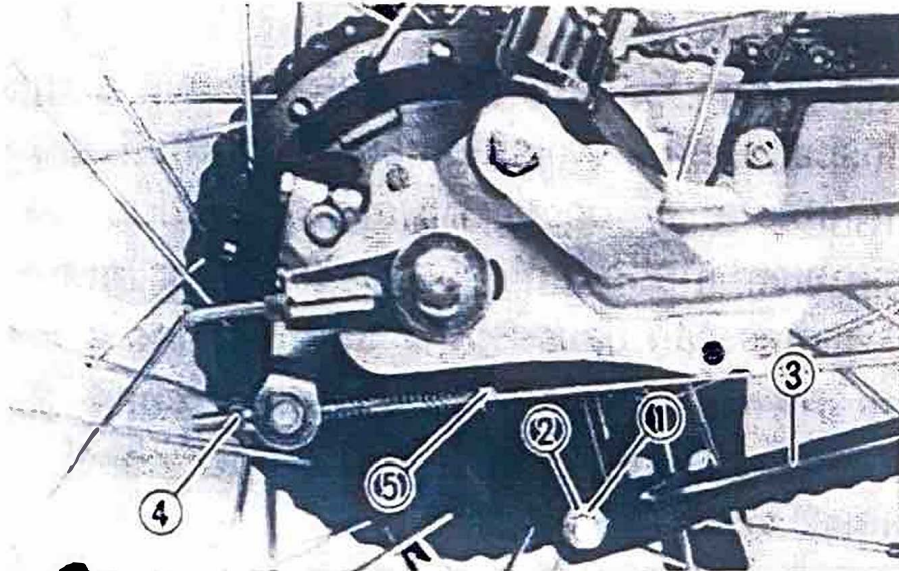

- 1. Cotter pin
- 2. Nut
- 3. Tension bar
- 4. Adjuster
- 5. Brake rod

3. Remove the axle nut cotter pin and the axle nut.

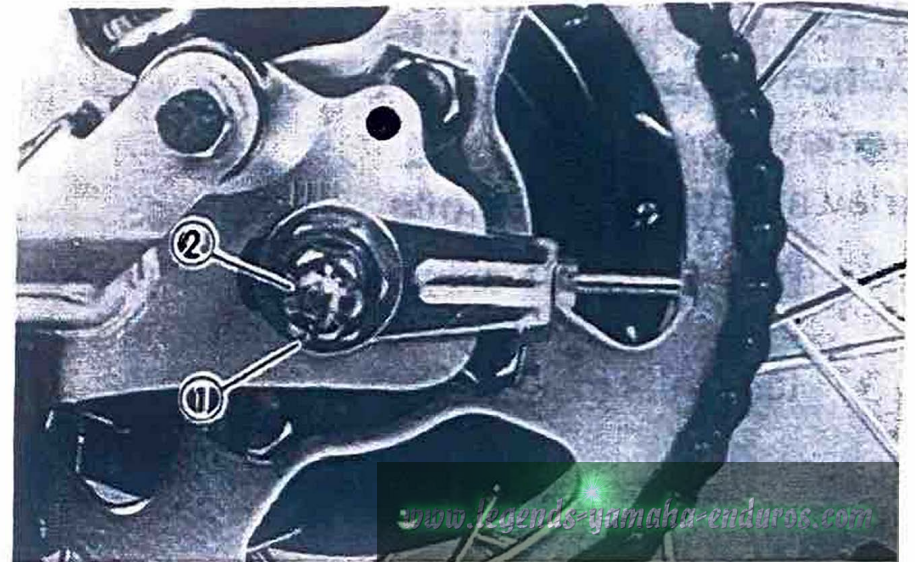

- 1. Cotter pin
- 2. Axle nut

4. The rear wheel assembly, the collar, can be removed from the machine by pulling the wheel axle.

U-056

NOTE: _____

You do not have to disassemble the chain in order to remove or install the rear wheel.

Rear wheel installation

When installing the rear wheel, reverse the removal procedure.

Pay attention to the following points:

1. Make sure the axle nut and tension bar bolt are properly torqued, and a new cotter pin is installed.

U-647

WARNING

Always use a new cotter pin on the axle nut and tension bar bolt.

Tightening torque:

Axle nut:

39 Nm (3.9 m·kg, 28 ft·lb)

Tension bar bolt:

18 Nm (1.8 m·kg, 13 ft·lb)

2. Adjust the rear brake. (See page 8-15.)

Troubleshooting

Although Yamaha machine receive a rigid inspection before shipment from the factory, trouble may occur during operation. Any problem in the fuel, compression, or ignition systems can cause poor starting and a loss of power. The troubleshooting chart describes a quick, easy procedure for checking these systems.

If your machine requires any repair, bring it to a Yamaha dealer. The skilled technicians at a Yamaha dealer have the tools, experience, and know-how to properly service your machine. Use only genuine Yamaha parts on your machine. Imitation parts may look like Yamaha parts, but they are often inferior. Consequently, they have a shorter service life and can lead to expensive repair bills.

Troubleshooting chart

⚠ WARNING

Never check the fuel system while smoking or in the vicinity of an open flame.

CJ5-04

1. Fuel

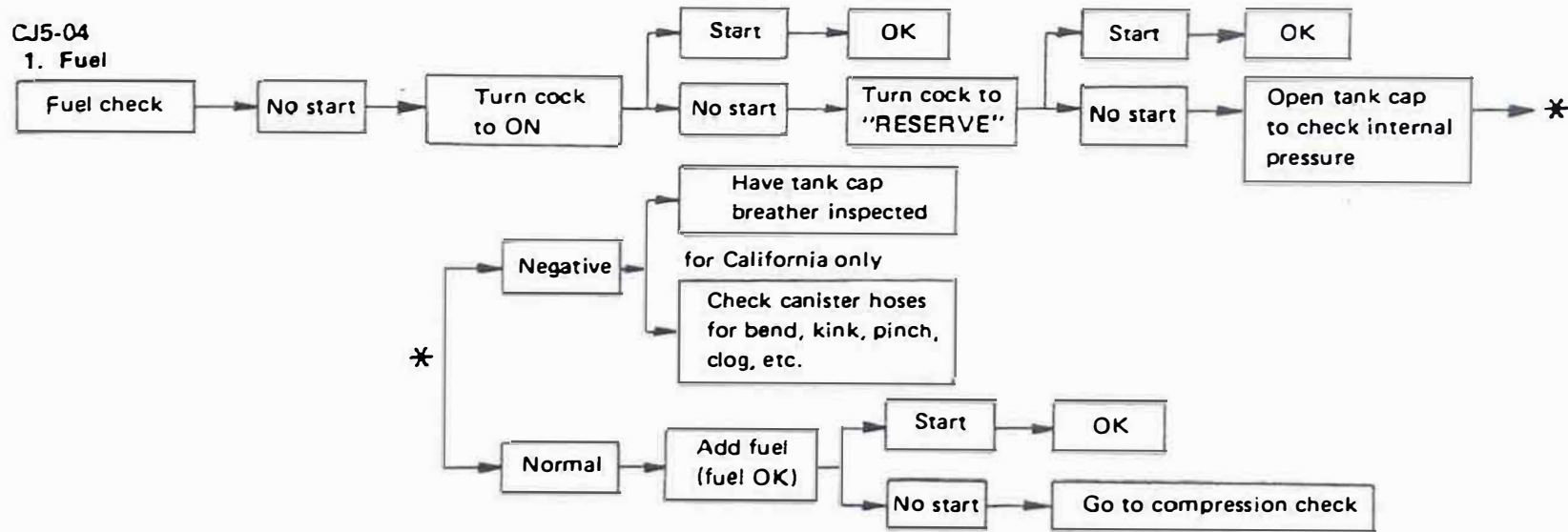

2. Compression

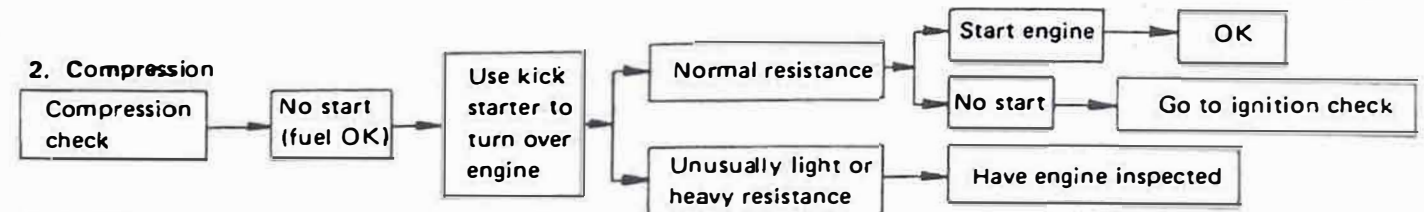

3. Ignition



CLEANING AND STORAGE

K-002

A. CLEANING

Frequent, thorough cleaning of your machine will not only enhance its appearance but will improve its general performance and extend the useful life of many components.

1. Before cleaning the machine:
 - a. Block off the end of exhaust pipe to prevent water entry; a plastic bag and strong rubber band may be used.
 - b. Make sure the spark plug(s) and all filler caps are properly installed.
2. If the engine case is excessively greasy, apply degreaser with a paint brush. Do not apply degreaser to the chain, sprockets, or wheel axles.
3. Rinse the dirt and degreaser off with a garden hose, use only enough pressure to do the job.

CAUTION:

Excessive hose pressure may cause water seepage and contamination of wheel bearings, front forks, brakes and transmission seals. Many expensive repair bills have resulted from improper high pressure detergent applications such as those available in coin-operated car washers.

4. Once the majority of the dirt has been hosed off, wash all surfaces with warm water and mild, detergent-type soap. An old tooth brush or bottle brush is handy for hard-to-get-to places.
5. Rinse the machine off immediately with clean water and dry all surfaces with a chamois, clean towel, or soft absorbent cloth.
6. Dry the chain and lubricate it to prevent rust.

7. Clean the seat with a vinyl upholstery cleaner to keep the cover pliable and glossy.
8. Automotive-type wax may be applied to all painted and chrome plated surfaces. Avoid combination cleaner-waxes. Many contain abrasives which may mar the paint or protective finish. When finished, start the engine and let it idle for several minutes.

K-005

B. STORAGE

Long term storage (60 days or more) of your machine will require some preventive procedures to guard against deterioration. After thoroughly cleaning the machine, prepare for storage as follows:

1. Drain the fuel tank, fuel lines, and carburetor float bowl(s).
2. Remove the spark plug, pour about one tablespoon of SAE 10W30 or 20W40 motor oil in the spark plug hole and

reinstall the spark plug. Kick the engine over several times (with ignition off) to coat the cylinder walls with oil.

3. Remove the drive chain. Clean it thoroughly with solvent and lubricate it. Reinstall the chain or store it in a plastic bag (tied to frame for safe-keeping).
4. Lubricate all control cables.
5. Block up the frame to raise both wheels off the ground.
6. Tie a plastic bag over the exhaust pipe outlet to prevent moisture from entering.
7. If storing in a humid or salt-air atmosphere, coat all exposed metal surfaces with a light film of oil. Do not apply oil to any rubber parts or the seat cover.

U-058

NOTE: _____

Make any necessary repairs before storing the machine.

SPECIFICATIONS

Model	RT100D
Dimension: Overall length Overall width Overall height Seat height Wheel base Minimum ground clearance	1,795 mm (70.7 in) 760 mm (29.9 in) 960 mm (37.8 in) 730 mm (28.7 in) 1,190 mm (46.9 in) 200 mm (7.9 in)
Basic weight: With oil and full fuel tank	79 kg (174 lb)
Minimum turning radius:	1,810 mm (71.3 in)
Engine: Type Model Cylinder arrangement Displacement Bore × Stroke Compression ratio Starting system Lubrication system	Air cooled 2-stroke, gasoline 3UL3 Single cylinder, Forward inclined 97 cm ³ 52.0 × 45.6 mm (2.05 × 1.80 in) 6.7 : 1 Kick starter Separate lubrication (Yamaha Autolube)

Model	RT100D
Engine oil (2-cycle): Type Capacity	Yamalube 2, Air cooled 2-stroke engine oil 1.0 L (0.88 Imp qt, 1.06 US qt)
Transmission oil: Type Capacity Periodic oil change Total amount	SAE 10W30 type SE motor oil 0.65 L (0.57 Imp qt, 0.69 US qt) 0.7 L (0.62 Imp qt, 0.74 US qt)
Air filter:	Wet type element
Fuel: Type: Tank capacity Reserve amount	UNLEADED FUEL 5.0 L (4.4 Imp gal, 5.3 US gal) 1.5 L (1.3 Imp gal, 1.6 US gal)
Carburetor: Type/manufacturer	VM22SS/MIKUNI
Spark plug: Type/manufacturer Gap	B7ES/NGK 0.5~0.6 mm (0.020 ~ 0.024 in)
Clutch type:	Wet, multi-disc

Model	RT100D
Transmission: Primary reduction system Primary reduction ratio Secondary reduction system Secondary reduction ratio Transmission type Operation Gear ratio 1st 2nd 3rd 4th 5th	Helical gear 74/19 (3.895) Chain drive 48/14 (3.429) Constant mesh 5-speed Left foot operation 35/11 (3.182) 30/15 (2.000) 26/19 (1.368) 23/23 (1.000) 20/25 (0.800)
Chassis: Frame type Caster angle Trail	Double cradle 29° 103 mm (4.1 in)
Tire: Type Size — Front Rear	With tube 2.50-18 4PR 3.00-16 4PR

Model	RT100D
Brake: Front brake type Operation Rear brake type Operation	Drum brake Right hand operation Drum brake Right foot operation
Suspension: Front Rear	Telescopic fork Swing arm
Shock absorber: Front Rear	Coil spring, Oil damper Coil spring, Oil damper
Wheel travel: Front Rear	110 mm (4.3 in) 84 mm (3.3 in)
Electrical: Ignition system Generator system	CDI magneto Flywheel magento

MOTORCYCLE NOISE REGULATION

TAMPERING WITH NOISE CONTROL SYSTEM PROHIBITED:

Federal law prohibits the following acts or the causing thereof: (1) The removal or rendering inoperative by any person other than for purposes of maintenance, repair, or replacement of any device or element of design incorporated into any new vehicle for the purpose of noise control prior to its sale or delivery to the ultimate purchaser or while it is in use or (2) the use of the vehicle after such device or element of design has been removed or rendered inoperative by any person.

“AMONG THOSE ACTS PRESUMED TO CONSTITUTE TAMPERING ARE THE ACTS LISTED BELOW.”

These acts include tampering with the following systems; i.e., modification, removal, etc.

CLO-04

Exhaust system	Muffler Exhaust pipe Silencer
Intake system	Air cleaner case Air cleaner element Intake duct

L-007

MAINTENANCE RECORD

Make sure whoever performs the maintenance completes this record.

CL0-05

MAINTENANCE INTERVAL	DATE OF SERVICE	MILEAGE	SERVICING DEALER NAME AND ADDRESS	REMARKS
1,000 km or 600 mi or 1 mo.				
6,000 km or 3,800 mi or 7 mo.				
11,000 km or 6,900 mi or 13 mo.				
16,000 km or 10,000 mi or 19 mo.				
21,000 km or 13,100 mi or 25 mo.				

MAINTENANCE INTERVAL	DATE OF SERVICE	MILEAGE	SERVICING DEALER NAME AND ADDRESS	REMARKS
26,000 km or 16,200 mi or 31 mo.				
31,000 km or 19,300 mi or 37 mo.				
36,000 km or 22,400 mi or 43 mo.				
41,000 km or 25,500 mi or 49 mo.				
46,000 km or 28,600 mi or 55 mo.				
51,000 km or 31,700 mi or 61 mo.				

YAMAHA MOTOR CORPORATION, U.S.A. OFF-ROAD MOTORCYCLE LIMITED WARRANTY

Yamaha Motor Corporation, U.S.A. hereby warrants that each new Yamaha off-road motorcycle purchased from an authorized Yamaha motorcycle dealer in the continental United States will be free from defects in material and workmanship for the period of time stated herein, subject to certain stated limitations.

THE PERIOD OF WARRANTY for Yamaha off-road motorcycles shall be ninety (90) days from the date of purchase, with no mileage limitation.

MODELS EXCLUDED FROM WARRANTY include those used for non-Yamaha-authorized renting, leasing, or other commercial purposes.

DURING THE PERIOD OF WARRANTY any authorized Yamaha motorcycle dealer will, free of charge, repair or replace, at Yamaha's option, any part adjudged defective by Yamaha due to faulty workmanship or material from the factory. Parts used in warranty repairs will be warranted for the balance of the product's warranty period. All parts replaced under warranty become property of Yamaha Motor Corp. U.S.A.

GENERAL EXCLUSIONS from this warranty shall include any failures caused by:

- a. Competition or racing use (except TY models used for sanctioned trials).
- b. Installation of parts or accessories that are not qualitatively equivalent to genuine Yamaha parts.
- c. Abnormal strain, neglect, or abuse.
- d. Lack of proper maintenance.
- e. Accident or collision damage.
- f. Modification to original parts.

SPECIFIC EXCLUSIONS from this warranty shall include parts replaced due to normal wear or routine maintenance.

THE CUSTOMER'S RESPONSIBILITY under this warranty shall be to:

1. Operate and maintain the motorcycle as specified in the appropriate Owner's Manual, and
2. Give notice to an authorized Yamaha motorcycle dealer of any and all apparent defects within ten (10) days after discovery, and make the machine available at that time for inspection and repairs at such dealer's place of business.

WARRANTY TRANSFER: To transfer the warranty from the original purchaser to any subsequent purchaser, it is imperative that the machine be inspected and registered for warranty by an authorized Yamaha motorcycle dealer. In order for this warranty to remain in effect, this inspection and registration must take place within ten (10) days after transfer. An inspection and registration fee will be charged for this service.

YAMAHA MOTOR CORPORATION, U.S.A. MAKES NO OTHER WARRANTY OF ANY KIND, EXPRESSED OR IMPLIED. ALL IMPLIED WARRANTIES OF MERCHANTABILITY AND FITNESS FOR A PARTICULAR PURPOSE WHICH EXCEED THE OBLIGATIONS AND TIME LIMITS STATED IN THIS WARRANTY ARE HEREBY DISCLAIMED BY YAMAHA MOTOR CORPORATION, U.S.A. AND EXCLUDED FROM THIS WARRANTY.

SOME STATES DO NOT ALLOW LIMITATIONS ON HOW LONG AN IMPLIED WARRANTY LASTS, SO THE ABOVE LIMITATION MAY NOT APPLY TO YOU. ALSO EXCLUDED FROM THIS WARRANTY ARE ANY IN-

CIDENTAL OR CONSEQUENTIAL DAMAGES INCLUDING LOSS OF USE. SOME STATES DO NOT ALLOW THE EXCLUSION OR LIMITATION OF INCIDENTAL OR CONSEQUENTIAL DAMAGES, SO THE ABOVE EXCLUSION MAY NOT APPLY TO YOU.

THIS WARRANTY GIVES YOU SPECIFIC LEGAL RIGHTS, AND YOU MAY ALSO HAVE OTHER RIGHTS WHICH VARY FROM STATE TO STATE.

YAMAHA MOTOR CORPORATION, U.S.A.
P. O. Box 6555
Cypress, California 90630

WARRANTY QUESTIONS AND ANSWERS

- Q. What costs are my responsibility during the warranty period?
- A. The customer's responsibility includes all costs of normal maintenance services, non-warranty repairs, accident and collision damages, and oil, oil filters, air filters, spark plugs, and brake shoes.
- Q. What are some examples of "abnormal" strain, neglect, or abuse?
- A. These terms are general and overlap each other in areas. Specific examples include: Running the machine out of oil, sustained high-rpm, full-throttle use; operating the machine with a broken or damaged part which causes another part to fail, damage or failure due to improper or careless transportation and or tie down; and so on. If you have any specific questions on operation or maintenance, please contact your dealer for advice.
- Q. Does the warranty cover incidental costs such as towing or transportation due to a failure?
- A. No. The warranty is limited to repair of the machine itself.
- Q. May I perform any or all of the recommended maintenance shown in the Owner's Manual instead of having the dealer do them?
- A. Yes, if you are a qualified mechanic and follow the procedures specified in the Owner's and Service Manual. We do recommend, however, that items requiring special tools or equipment be done by a Yamaha motorcycle dealer.
- Q. Will the warranty be void or cancelled if I do not operate or maintain my new motorcycle exactly as specified in the Owner's Manual?
- A. No. The warranty on a new motorcycle cannot be "voided" or "cancelled." However, if a particular failure is caused by operation or maintenance other than as shown in the Owner's Manual, that failure may not be covered under warranty.
- Q. What responsibility does my dealer have under this warranty?
- A. Each Yamaha motorcycle dealer is expected to:
1. Completely set up every new machine before sale.
 2. Explain the operation, maintenance, and warranty requirements to your satisfaction at the time of sale, and upon your request at any later date.
- Q. Is the warranty transferable to second owners?
- A. Yes. The remainder of the existing warranty can be transferred upon request. The unit has to be inspected and re-registered by an authorized Yamaha motorcycle dealer for the policy to remain effective.

CUSTOMER SERVICE

If your machine requires warranty service, you must take it to any authorized Yamaha motorcycle dealer within the continental United States. Be sure to bring your warranty registration identification or other valid proof of the original date of purchase. If a question or problem arises regarding warranty, first contact the owner of the dealership. Since all warranty matters are handled at the dealer level, this person is in the best position to help you. If you are still not satisfied and require additional assistance, please write:

YAMAHA MOTOR CORPORATION U.S.A.
CUSTOMER RELATIONS DEPARTMENT
P.O. Box 6555
Cypress, California 90630

When contacting Yamaha Motor Corporation, U.S.A. don't forget to include any important information such as names, addresses, model, engine serial number, dates, and receipts.

CHANGE OF ADDRESS

The federal government requires each manufacturer of a motor vehicle to maintain a complete, up-to-date list of all first purchasers against the possibility of a safety-related defect and recall. This list is compiled from the purchase registrations sent to Yamaha Motor Corporation, U.S.A. by the selling dealer at the time of your purchase.

If you should move after you have purchased your new motorcycle, please advise us of your new address by sending a postcard listing your motorcycle model name, engine serial number, dealer number (or dealer's name) as it is shown on your warranty identification, your name and new mailing address. Mail to:

YAMAHA MOTOR CORPORATION, U.S.A.
P.O. Box 6555
Cypress, California 90630

This will ensure that Yamaha Motor Corporation, U.S.A. has an up-to-date registration record in accordance with federal law.

WIRING DIAGRAM

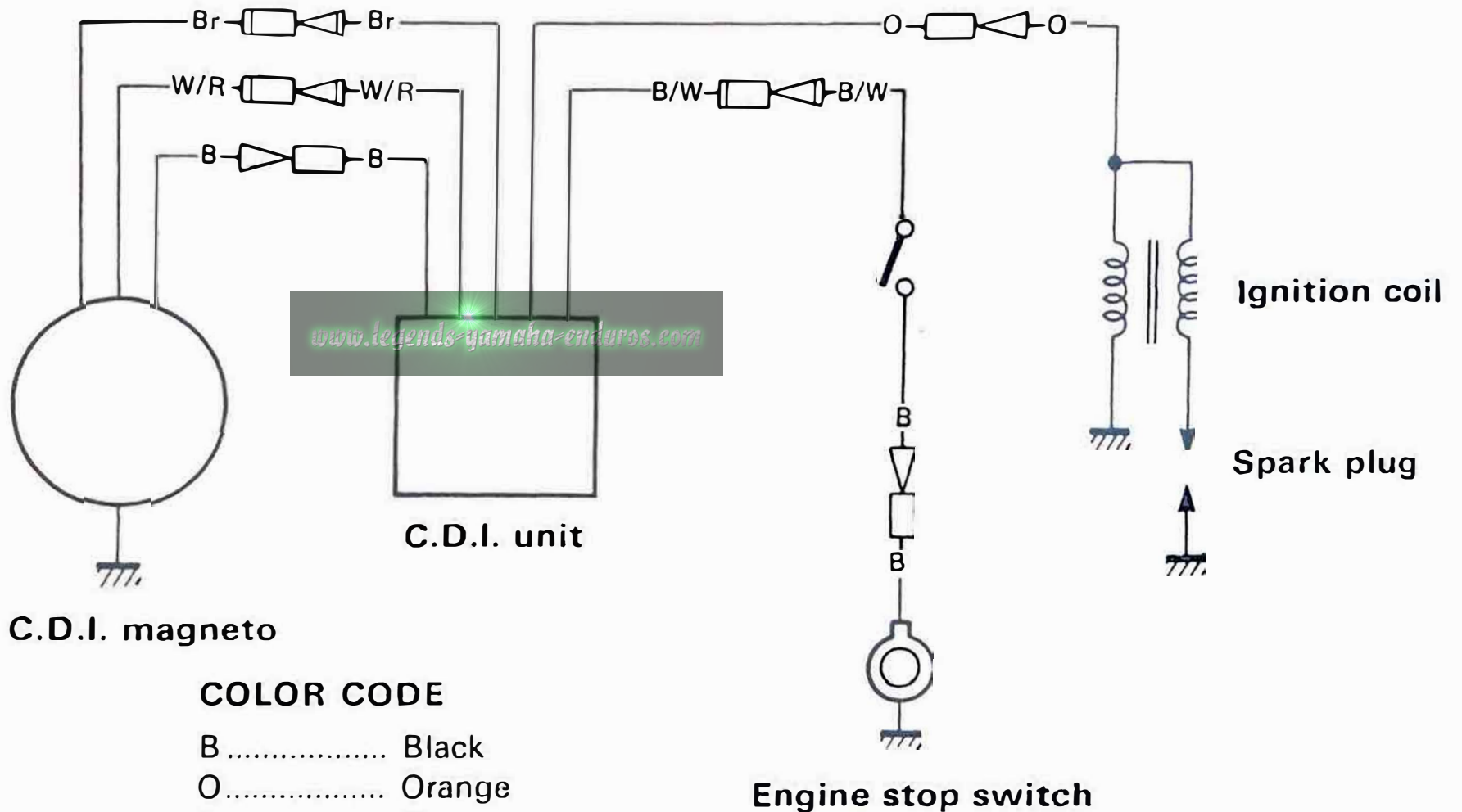

PROTECT YOUR INVESTMENT
Use Genuine YAMAHA Parts And Accessories

www.legends-yamaha-enduros.com

See your Authorized YAMAHA Dealer for a Genuine YAMAHA Service Manual.



YAMAHA MOTOR CO., LTD.

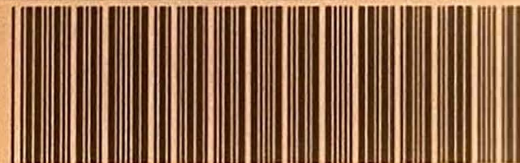

LIT-11626-08-23