

# YAMAHA DT50M

YAMAHA



[www.legends-yamaha-enduros.com](http://www.legends-yamaha-enduros.com)

# Big-hearted lightweight on the en

Just like the rest of the famous Yamaha of Enduro range of dual purpose street/trail bikes, the new DT50M is equally at home on city streets or out in the rough country. Only difference between the DT50M and its bigger brothers, is its lack of cubic inches...and to those riders whose preference tends towards lightweight machines, that won't matter a bit.

The DT50M is a enduro machine on a small scale; a great little street bike that can carry you across the city to work or out on the country lanes - but still a bike with off-road capability.

Sharing the same tough little five-speed, Torque Induction engine as the TY50 trial machine, the Enduro-styled DT50M features a large capacity 6.0 litre tank (plus separate oil tank for the Autolube engine), braced handlebars and enduro mudguards.

The high level exhaust pipe with heatshield completes the sporty look of this ultra-lightweight especially designed with a dual-purpose role in mind.

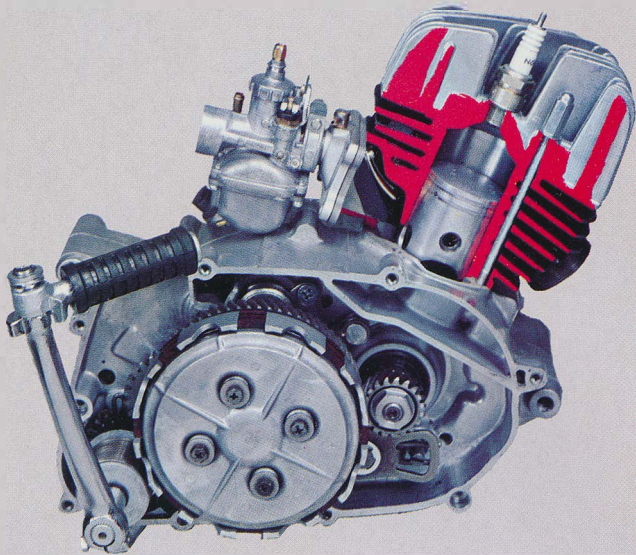

## Engine:

Yamaha's famous Torque Induction reed valve system gives the DT50M engine the flexibility of bikes three times its size and this, plus the five speed gearbox make the bike a zippy little performer on tarmac or trail. Reliability is ensured by the famous Yamaha Autolube system that feeds oil into the engine under pressure via a pump controlled by the throttle. The engine gets exactly the amount of oil necessary at any given speed.

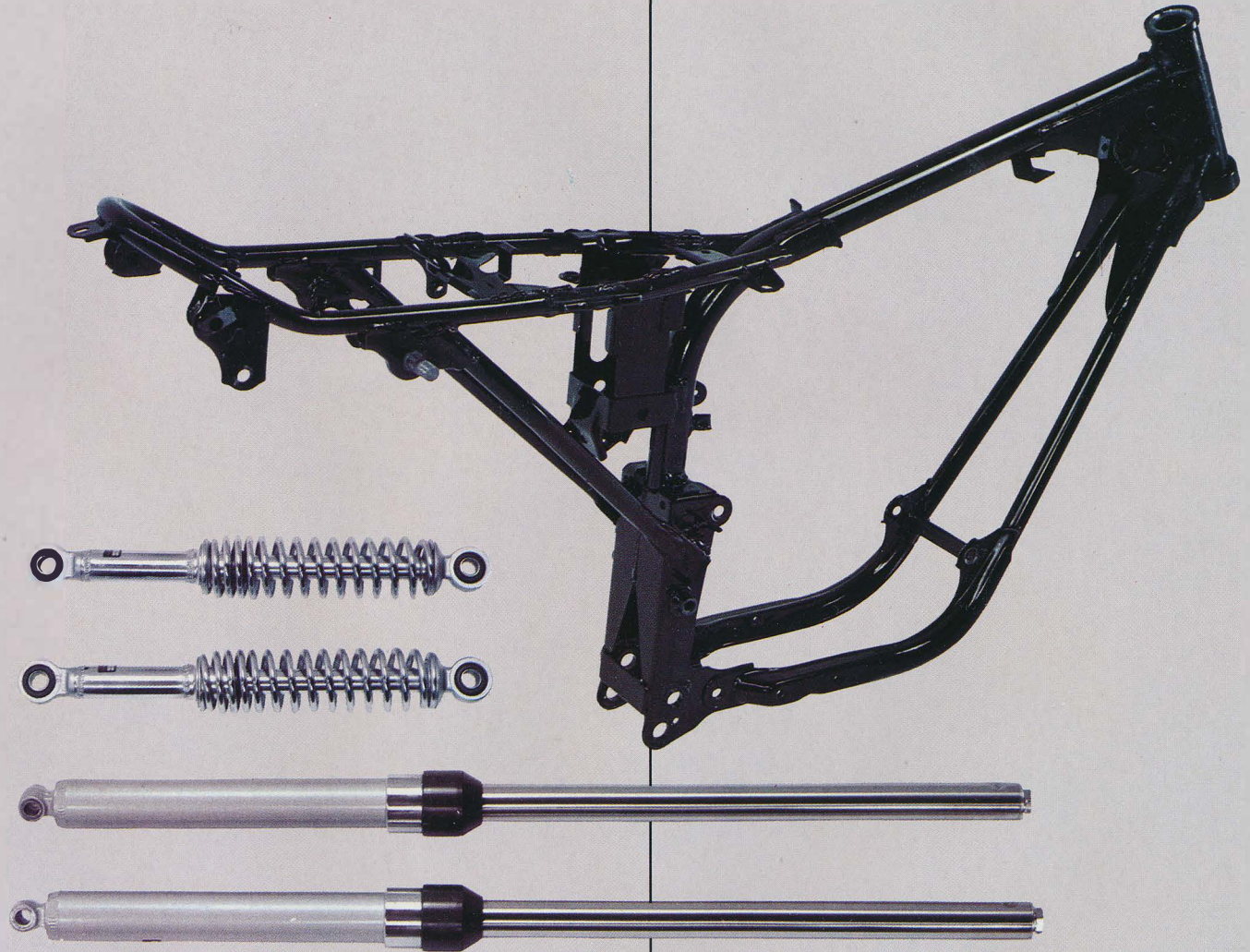

## Suspension:

As befits a machine of this type, the DT50M features hydraulic front forks and rear shock absorbers, just like larger models in the Enduro line-up. The DT50M is no ordinary lightweight masquerading as an Enduro machine. Rugged suspension front and rear give the machine true off-road capabilities.

## Frame:

The engine unit itself forms a stressed part of the chassis for added rigidity and strength. The chassis unit is light in weight but is especially strengthened to cope with the off-road aspects of the DT50M.

# duro trail—The Yamaha DT50M.



## SPECIFICATIONS

### ENGINE

Type	2-stroke, Torque Induction, Single
Displacement	49 cc
Bore & Stroke	40.0 × 39.7 mm
Compression ratio	6.8:1
Lubrication system	Autolube
Starting system	Kick starter
Primary transmission	Gear
Gear Box	5-speed
Carburettor	VM16SH
Clutch	Multi-plate, Wet
Battery	6V, 4AH
Charging system	Flywheel magneto
Ignition type	Magneto

### DIMENSIONS

Overall length	1,860 mm
Overall width	775 mm
Overall height	1,010 mm
Wheelbase	1,210 mm
Seat height	765 mm
Weight	72 kg
Fuel tank capacity	4.7 lit.
Oil tank capacity	1.2 lit.
Tires front	2.50-19-4PR
rear	3.00-17-4PR
Brakes front	Drum
rear	Drum

\* Specifications subject to change without notice.

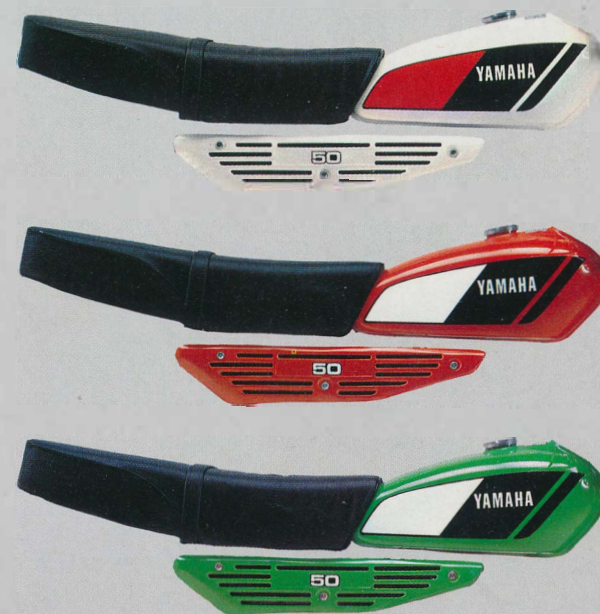
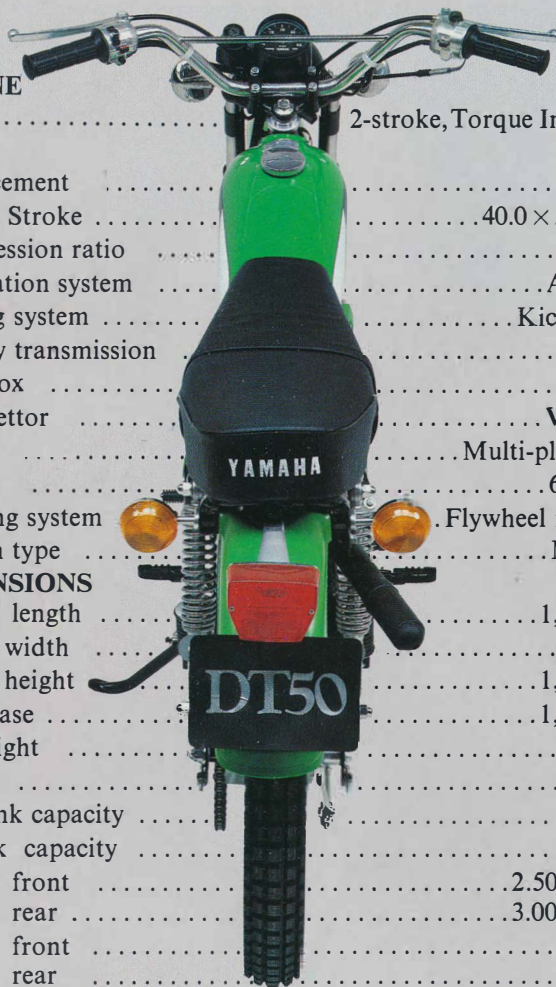

[www.legends-yamaha-enduros.com](http://www.legends-yamaha-enduros.com)



**YAMAHA MOTOR N. V.**

Postbus 7829 PROF. E. M. Meyerslaan 3  
Amstelveen (Amsterdam), Holland