

YAMAHA

www.legends-yamaha-enduros.com

OWNER'S MANUAL

RT 100E

LIT-11626-08-54

3UL-28199-13

Cyndy Hovey
P.O. Box 13
Nowood



PRODUCT IDENTIFICATION

Y.E.S. 12 MONTHS BEYOND NORMAL WARRANTY 24 MONTHS BEYOND NORMAL WARRANTY 36 MONTHS BEYOND NORMAL WARRANTY

| | |
|----------------------------|----------------------|
| MODEL RT100E | DEALER NO. 162680 |
| PRIMARY I.D. 3UL-045540 | DATE SOLD 8-12-93 |

EAA00000

www.legends-yamaha-enduros.com

**RT100E
OWNER'S MANUAL**
©1992 by Yamaha Motor Corporation, U.S.A.
1st Edition, May 1992
All rights reserved. Any reprinting or
unauthorized use without the written
permission of Yamaha Motor Corporation,
U.S.A. is expressly prohibited.
Printed in Japan
P/N LIT-11626-08-54

⚠ WARNING

THIS MACHINE IS DESIGNED AND MANUFACTURED FOR OFF-ROAD USE ONLY. IT IS ILLEGAL TO OPERATE THIS MACHINE ON ANY PUBLIC STREET, ROAD OR HIGHWAY. SUCH USE IS PROHIBITED BY LAW. THIS MACHINE COMPLIES WITH ALMOST ALL STATE OFF-HIGHWAY NOISE LEVEL AND SPARK ARRESTER LAWS AND REGULATIONS. PLEASE CHECK YOUR LOCAL RIDING LAWS AND REGULATIONS BEFORE OPERATING THIS MACHINE.

INTRODUCTION

Congratulations on your purchase of the Yamaha RT100E. This model is the result of Yamaha's vast experience in the production of fine sporting, touring, and pacesetting racing machines. It represents the high degree of craftsmanship and reliability that have made Yamaha a leader in these fields.

This manual will give you an understanding of the operation, inspection, and basic maintenance of this machine. If you have any questions about the operation or maintenance of your machine, please consult a Yamaha dealer.

The design and manufacture of this Yamaha machine fully comply with the emissions standards for clean air applicable at the date of manufacture. Yamaha has met these standards without reducing the machine's performance or economy of operation. To maintain these high standards, it is important that you and your dealer pay close attention to the recommended maintenance schedules and operating instructions contained within this manual.

Particularly important information is distinguished in this manual by the following notations:



The Safety Alert Symbol means **ATTENTION! BECOME ALERT! YOUR SAFETY IS INVOLVED!**



Failure to follow **WARNING** instructions could result in severe injury or death to the machine operator, a bystander or a person inspecting or repairing the machine.



A **CAUTION** indicates special precautions that must be taken to avoid damage to the machine.

NOTE:

A **NOTE** provides key information to make procedures easier or clearer.

NOTE:

This manual should be considered a permanent part of this machine and should remain with it even if the machine is subsequently sold.

NOTE:

Yamaha continually seeks advancements in product design and quality. Therefore, while this manual contains the most current product information available at the time of printing, there may be minor discrepancies between your machine and this manual. If there is any question concerning this manual, please consult your Yamaha dealer.

! WARNING

PLEASE READ THIS MANUAL CAREFULLY AND COMPLETELY BEFORE OPERATING THIS MACHINE. DO NOT ATTEMPT TO OPERATE THIS MOTORCYCLE UNTIL YOU HAVE ATTAINED A SATISFACTORY KNOWLEDGE OF ITS CONTROLS AND OPERATING FEATURES AND UNTIL YOU HAVE BEEN TRAINED IN SAFE AND PROPER RIDING TECHNIQUES. REGULAR INSPECTIONS AND CAREFUL MAINTENANCE, ALONG WITH GOOD RIDING SKILLS, WILL ENSURE THAT YOU SAFELY ENJOY THE CAPABILITIES AND THE RELIABILITY OF THIS MOTORCYCLE.

CONTENTS

| | | | |
|---------------------------------------|-----|--|-----|
| SAFETY INFORMATION | 1-1 | Kick starter | 5-4 |
| LOCATION OF THE IMPORTANT LABELS..... | 2-1 | Seat..... | 5-4 |
| DESCRIPTION | 3-1 | Side cover removal | 5-5 |
| MACHINE IDENTIFICATION | 4-1 | Rear shock absorber | 5-5 |
| Vehicle identification number..... | 4-1 | PRE-OPERATION CHECKS | 6-1 |
| Engine serial number | 4-1 | Brakes | 6-3 |
| CONTROL FUNCTIONS..... | 5-1 | Clutch..... | 6-3 |
| Clutch lever..... | 5-1 | Throttle grip | 6-3 |
| Shift pedal | 5-1 | Engine oil | 6-3 |
| Front brake lever | 5-2 | Transmission oil | 6-4 |
| Rear brake pedal | 5-2 | Chain..... | 6-4 |
| Rear brake lever | 5-2 | Tires | 6-4 |
| Fuel tank cap | 5-2 | Wheels..... | 6-7 |
| Fuel cock..... | 5-3 | Accessories or replacement parts | 6-7 |
| Starter knob (CHOKE)..... | 5-3 | Fittings/Fasteners | 6-8 |
| | | Switch..... | 6-8 |
| | | Fuel | 6-8 |

| | | | |
|--|------|--|------|
| OPERATION AND IMPORTANT RIDING POINTS | 7-1 | Front brake adjustment | 8-13 |
| Starting and warming up | | Rear brake adjustment | 8-14 |
| a cold engine..... | 7-1 | Brake lining inspection | 8-15 |
| Starting a warm engine | 7-2 | Clutch adjustment | 8-16 |
| Shifting | 7-2 | Drive chain slack check | 8-17 |
| To start out and accelerate..... | 7-3 | Drive chain slack adjustment | 8-17 |
| To decelerate | 7-3 | Drive chain lubrication | 8-19 |
| Engine break-in | 7-4 | Cable inspection and lubrication | 8-20 |
| Parking | 7-5 | Throttle cable and grip lubrication ... | 8-20 |
| | | Autolube pump adjustment | 8-20 |
| PERIODIC MAINTENANCE AND MINOR REPAIR | 8-1 | Brake and shift pedals | 8-21 |
| Tool kit..... | 8-2 | Brake and clutch levers | 8-21 |
| Periodic maintenance / lubrication | 8-3 | Sidestand | 8-21 |
| Spark plug inspection | 8-5 | Rear suspension | 8-21 |
| Torque specifications | 8-7 | Front fork inspection | 8-21 |
| Transmission oil..... | 8-8 | Rear shock absorber adjustment | 8-22 |
| Air filter | 8-10 | Wheel bearings | 8-23 |
| Carburetor adjustment..... | 8-11 | Front wheel removal | 8-23 |
| Idle speed adjustment..... | 8-11 | Front wheel installation | 8-24 |
| Throttle cable adjustment..... | 8-13 | Rear wheel removal | 8-24 |
| | | Rear wheel installation | 8-26 |
| | | Troubleshooting | 8-26 |

| | |
|--|-------------|
| Troubleshooting chart..... | 8-27 |
| CLEANING AND STORAGE..... | 9-1 |
| A. Cleaning | 9-1 |
| B. Storage | 9-2 |
| SPECIFICATIONS..... | 10-1 |
| MACHINE NOISE REGULATION | 11-1 |
| MAINTENANCE RECORD..... | 12-1 |
| OFF-ROAD MACHINE LIMITED WARRANTY | 13-1 |
| WIRING DIAGRAM..... | 14-1 |

⚠ SAFETY INFORMATION

TWO-WHEELED MACHINES ARE SINGLE TRACK VEHICLES. THEIR SAFE USE AND OPERATION ARE DEPENDENT UPON THE USE OF PROPER RIDING TECHNIQUES AS WELL AS THE EXPERTISE OF THE OPERATOR.

EVERY OPERATOR SHOULD KNOW THE FOLLOWING REQUIREMENTS BEFORE RIDING.

HE OR SHE SHOULD:

- 1. OBTAIN THOROUGH INSTRUCTIONS FROM A COMPETENT SOURCE ON ALL ASPECTS OF MACHINE OPERATION.**
- 2. OBSERVE THE WARNINGS AND MAINTENANCE REQUIREMENTS IN THE OWNER'S MANUAL.**
- 3. OBTAIN QUALIFIED TRAINING IN SAFE AND PROPER RIDING TECHNIQUES.**
- 4. OBTAIN PROFESSIONAL TECHNICAL SERVICE AS INDICATED BY THE OWNER'S MANUAL AND/OR WHEN MADE NECESSARY BY MECHANICAL CONDITIONS.**

SAFE RIDING

- 1. Always make pre-operation checks. Careful checks may help prevent an accident.**
- 2. This machine is designed for off-road use only. It is illegal for this machine to be operated on any public street, road, or highway. Off-road use on public lands may be illegal. Please check local regulations before riding.**
- 3. This machine is designed to carry the operator only. No passengers.**
- 4. Many accidents involve inexperienced operators.**
 - a. Know your skills and limits. Staying within your limits may help you to avoid an accident.**
 - b. Only lend your machine to experienced operators.**
- 5. Many machine accidents have been caused by machine operator errors. A typical error made by the operator is veering wide on a turn due to EXCESSIVE SPEED or undercornering (insufficient lean angle for the speed). Never travel faster than warranted by conditions.**
- 6. Ride cautiously in unfamiliar areas. You may encounter hidden obstacles which could cause an accident.**
- 7. The operator's posture is important for proper control. The operator should keep both hands on the handlebars and both feet on the operator footrests during operation to maintain control of the machine.**
- 8. Never ride under the influence of alcohol or drugs.**

PROTECTIVE APPAREL

The majority of fatalities from machine accidents are the result of head injuries. The use of a safety helmet is the single most critical factor in the prevention or reduction of head injuries.

- 1. Always wear an approved helmet.**
- 2. Wear a face shield or goggles. Wind on your unprotected eyes could contribute to an impairment of vision which could delay seeing a hazard.**
- 3. The use of heavy boots, jacket, trousers, gloves, etc. is effective in preventing or reducing abrasions or lacerations.**
- 4. Never wear loose fitting clothing. It could catch on the control levers, footrests, or wheels and cause injury or accident.**
- 5. Never touch the engine or exhaust system during or after operation. They become very hot and can cause burns. Always wear protective clothing that covers your legs, ankles, and feet.**

MODIFICATION

Modifications made to the machine not approved by Yamaha, or the removal of original equipment, may render your machine unsafe for use and may cause severe personal injury. Modifications may also make your machine illegal to use.

LOADING AND ACCESSORIES

Adding accessories or cargo to your machine can adversely affect stability and handling if the weight distribution of the machine is changed. To avoid the possibility of an accident, extreme caution should be used if adding cargo or accessories to your machine. Use extra care if riding a machine which has added cargo or accessories.

Genuine Yamaha accessories have been specifically designed for use on this machine. Since Yamaha cannot test all other accessories which may be available, you must personally be responsible for the proper selection, installation and use of non-Yamaha accessories. You should use extreme caution when selecting and installing any accessories. Keep in mind these guidelines for mounting accessories in addition to those provided under "LOADING."

- 1. Never install accessories or carry cargo that would impair the performance of your machine. Carefully inspect the accessory before using it to make sure it does not in any way reduce ground clearance or cornering clearance, limit suspension travel, steering travel or control operation, or obscure lights or reflectors.**
 - a. Accessories fitted to the handlebar or the front fork area can create instability due to improper weight distribution or aerodynamic changes. If accessories are added to the handlebar or front fork area, they must be as lightweight as possible and should be kept to a minimum.**

- b. **Bulky or large accessories may seriously affect the stability of the machine due to aerodynamic effects. Wind may attempt to lift the machine, or the machine may become unstable in cross winds. These accessories may also cause instability when being passed by or passing large vehicles.**
 - c. **Certain accessories can displace the operator from his or her normal riding position. This improper position limits the freedom of movement of the operator and may limit control ability. Therefore such accessories are not recommended.**
- 2. Caution must be used if adding electrical accessories. If these accessories exceed the capacity of the machine's electrical system, an electric failure could result, which could cause a dangerous loss of lights or engine power.**

GASOLINE AND EXHAUST GAS

www.legends-yamaha-enduros.com

- 1. GASOLINE IS HIGHLY FLAMMABLE:**
- a. **Always turn off the engine when refueling.**
 - b. **Take care not to spill any gasoline on the engine or exhaust pipe(s)/muffler(s) when refueling.**
 - c. **Never refuel while smoking or in the vicinity of an open flame.**
- 2. Never start the engine or let it run for any length of time in a closed area. The exhaust fumes are poisonous and may cause loss of consciousness and death within a short time. Always operate your motorcycle in an area that has adequate ventilation.**

- 3. Always turn off the engine before leaving the machine unattended and remove the ignition key. When parking the machine, note the following:**
 - a. The engine and exhaust pipe(s)/muffler(s) may be hot. Park the machine in a place where pedestrians or children are not likely to touch these hot areas.**
 - b. Do not park the machine on a slope or soft ground; the machine may fall over.**
 - c. Do not park the machine near a flammable source, e.g. a kerosene heater, or near an open flame. The machine could catch fire.**
- 4. When transporting the machine in another vehicle, be sure it is kept upright and that the fuel cock(s) is turned to "ON" or "RES" (for vacuum type)/"OFF" (for manual type). If it should lean over, gasoline may leak out of the carburetor or fuel tank.**
- 5. If you should swallow any gasoline, inhale a lot of gasoline vapor, or allow gasoline to get in your eye(s), see your doctor immediately. If any gasoline spills on your skin or clothing, immediately wash it off with soap and water and change your clothes.**

LOCATION OF THE IMPORTANT LABELS

Please read the following labels carefully before operating this machine.

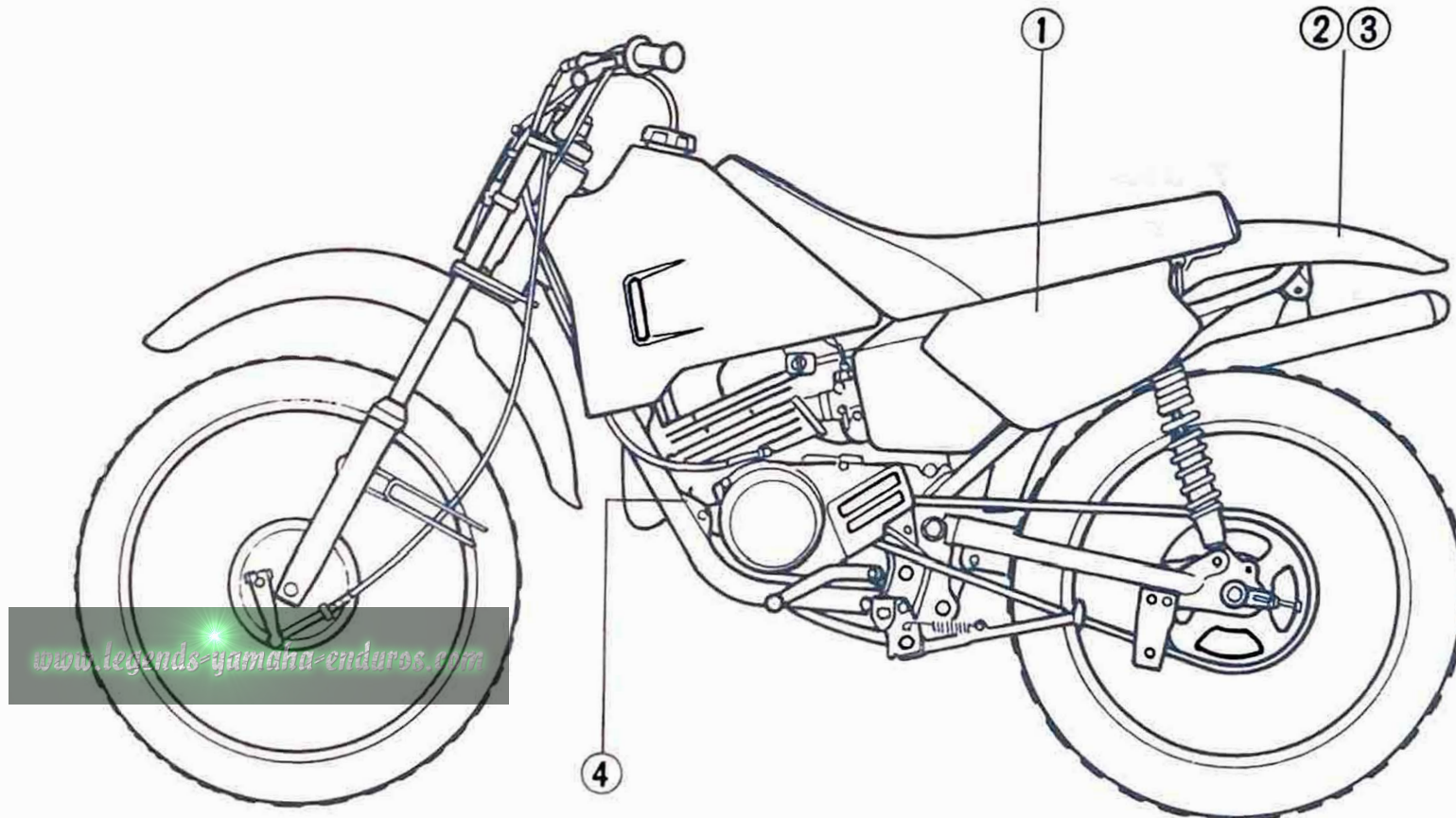

①

⚠ WARNING

- **BEFORE YOU OPERATE THIS VEHICLE, READ THE OWNER'S MANUAL AND ALL LABELS.**
- **NEVER CARRY A PASSENGER.** You increase your risk of losing control if you carry a passenger.
- **NEVER OPERATE THIS VEHICLE ON PUBLIC ROADS.** You can collide with another vehicle if you operate this vehicle on a public road.
- **ALWAYS WEAR AN APPROVED MOTORCYCLE HELMET, eye protection, and protective clothing.**

3XJ-2118K-00

②

⚠ WARNING

Riding as a passenger can cause the vehicle to go out of control.

Loss of control can cause a collision or rollover, which can result in severe injury or death.

NEVER ride as a passenger.

YAMAHA

3XJ-2151H-00

③

TIRE INFORMATION

Cold tire normal pressure should be set as follows.

FRONT : 125 kPa, {1.25 kgf/cm²}, 18 psi

REAR : 125 kPa, {1.25 kgf/cm²}, 18 psi

YAMAHA

3UL-21668-00

www.legends-yamaha-enduros.com

④

MOTORCYCLE NOISE EMISSION CONTROL INFORMATION. YAMAHA MOTOR CO., LTD

YAMAHA

THIS MOTORCYCLE MEETS **** AND LATER EPA NOISE EMISSION REQUIREMENTS OF THE FEDERAL TEST PROCEDURE. MODIFICATIONS WHICH CAUSE THIS MOTORCYCLE TO EXCEED FEDERAL NOISE STANDARD ARE PROHIBITED BY FEDERAL LAW SEE OWNER'S MANUAL.

LIMIT/CLOSING : *** dBA/**** r/min MODEL CODE : ****

DESCRIPTION

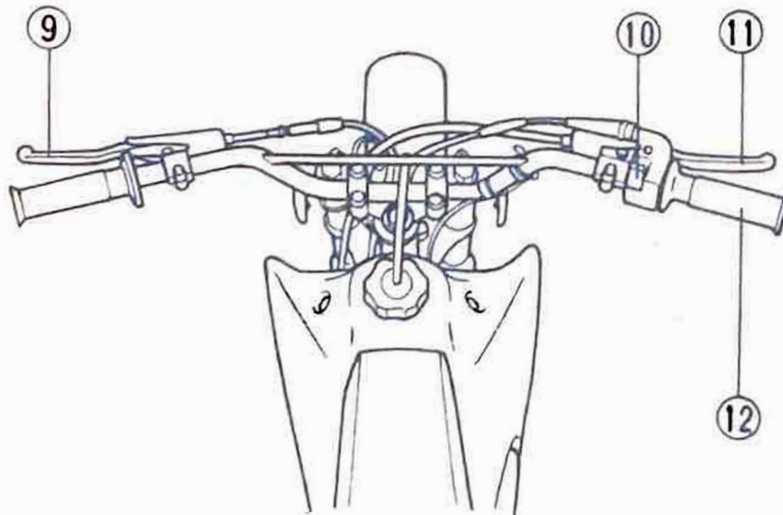
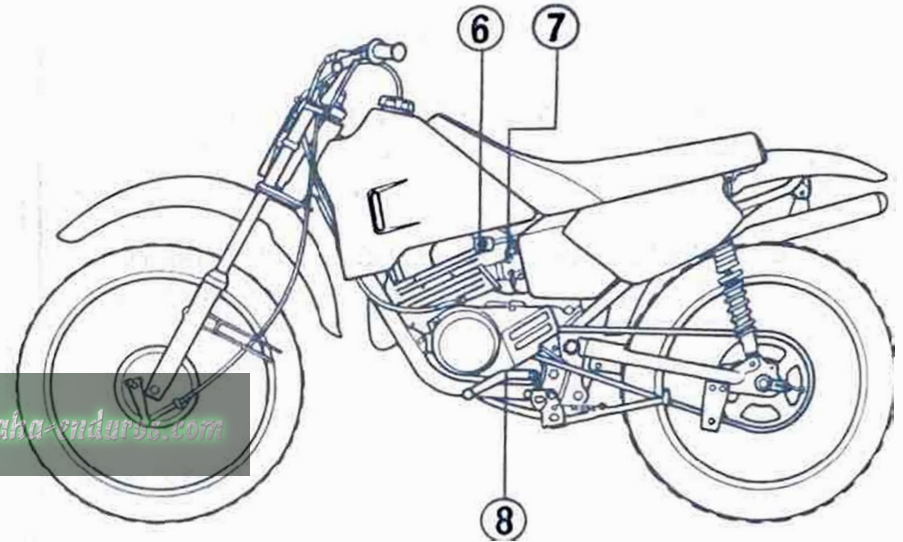
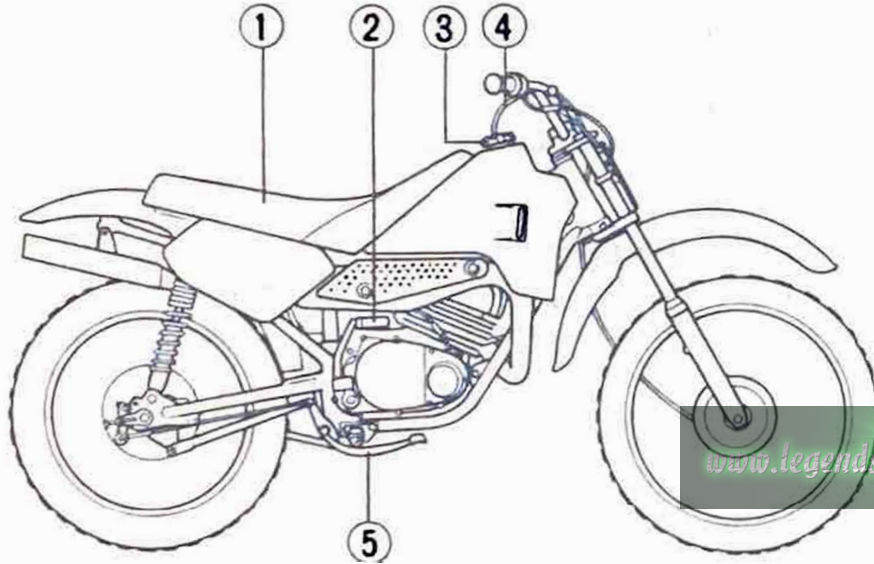

- 1. Seat
- 2. Kick starter
- 3. Fuel tank cap
- 4. Fuel tank breather hose
- 5. Rear brake pedal
- 6. Fuel cock

- 7. Starter knob (CHOKE)
- 8. Shift pedal
- 9. Clutch lever
- 10. "ENGINE STOP" switch
- 11. Front brake lever
- 12. Throttle grip

MACHINE IDENTIFICATION

Vehicle identification number

The vehicle identification number is stamped into the steering head pipe.

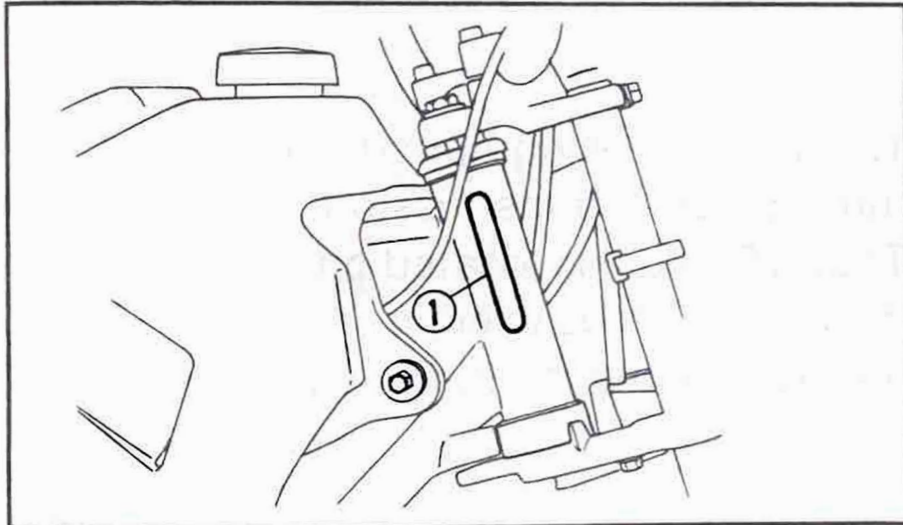

1. Vehicle identification number

NOTE: _____
The vehicle identification number is used to identify your machine and may be used to register your machine with the licensing authority in your state.

Engine serial number

The engine serial number is stamped into the crankcase.



1. Engine serial number

NOTE: _____
The first three digits of these numbers are for model identification; the remaining digits are the unit production number. Keep a record of these numbers for reference when ordering parts from a Yamaha dealer.

EAB00000

CONTROL FUNCTIONS

EAB60901

"ENGINE STOP" switch

The engine stop switch is a safety device for use in an emergency such as when the machine overturns or if trouble occurs in the throttle system. Turn the switch to "RUN" to start the engine. In case of emergency, turn the switch to "OFF" to stop the engine.

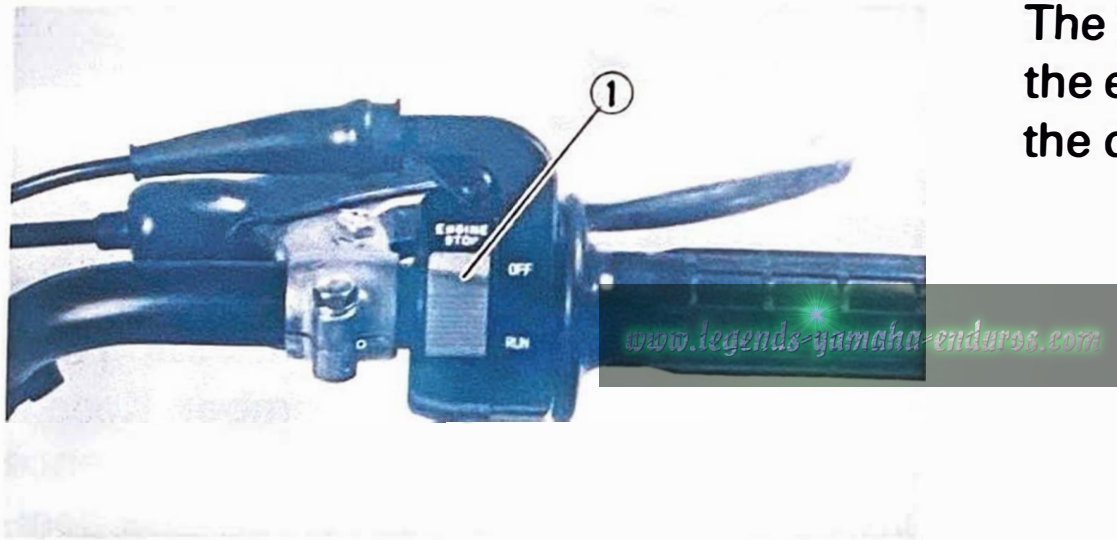

1. "ENGINE STOP" switch

EAB70101

Clutch lever

The clutch lever is located on the left handlebar. Pull the clutch lever to the handlebar to disengage the clutch, and release the lever to engage the clutch. The lever should be pulled rapidly and released slowly for smooth clutch operation.

EAB80001

Shift pedal

This machine is equipped with a constant-mesh 5-speed transmission.

The shift pedal is located on the left side of the engine and is used in combination with the clutch when shifting.

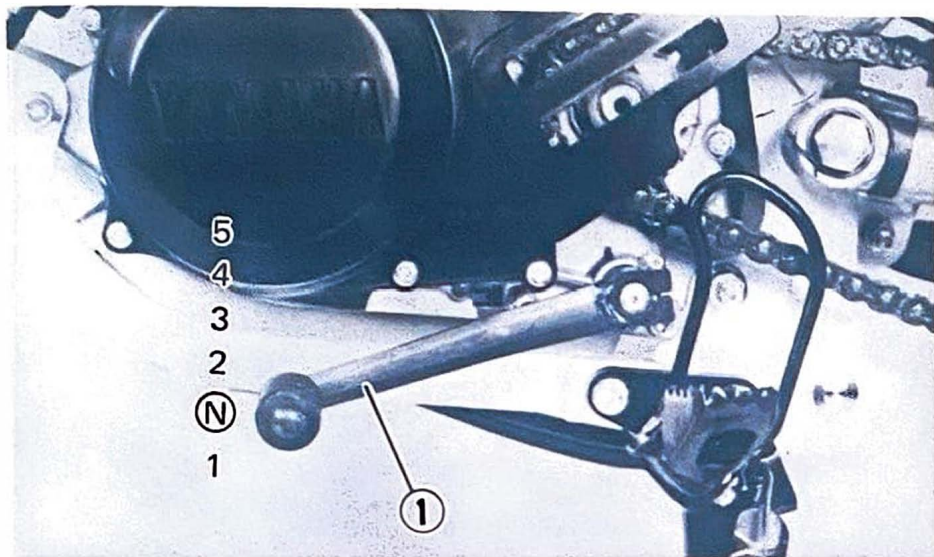

N. Neutral

1. Shift pedal

EAB90001

Front brake lever

The front brake lever is located on the right handlebar. Pull it toward the handlebar to apply the front brake.

EAB90101

Rear brake pedal

The rear brake pedal is on the right side of the machine. Press down on the brake pedal to apply the rear brake.

EAB90201

Rear brake lever

The rear brake lever is located on the left handlebar. Pull it toward the handlebar to apply the rear brake.

EAC01100

Fuel tank cap

Remove the fuel tank cap by turning it counterclockwise.

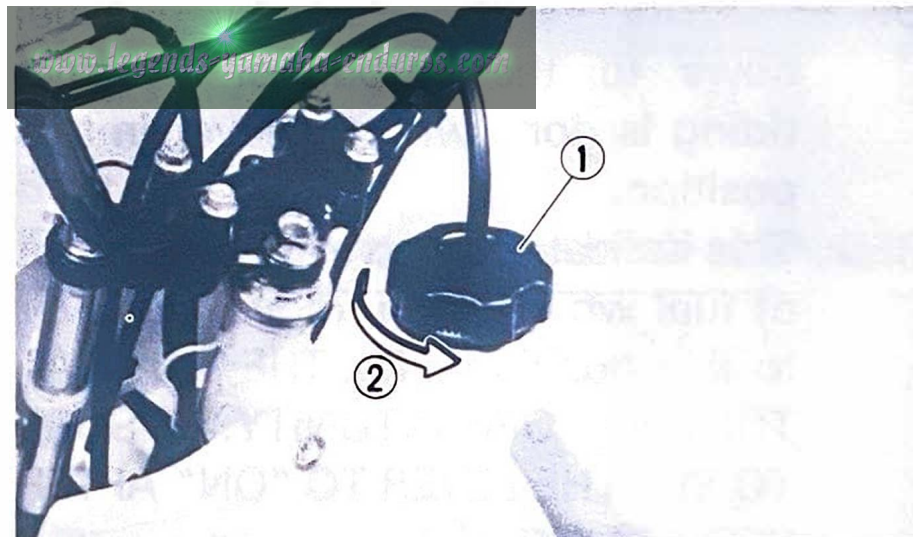

1. Fuel tank cap

2. Open

Fuel cock

The fuel cock supplies fuel from the tank to the carburetor(s) while filtering it also.

The fuel cock has three positions:

OFF: With the lever in this position, fuel will not flow. Always return the lever to this position when the engine is not running.

ON: With the lever in this position, fuel flows to the carburetor. Normal riding is done with the lever in this position.

RES: This indicates reserve. If you run out of fuel while riding, move the lever to this position. FILL THE TANK AT THE FIRST OPPORTUNITY. BE SURE TO SET THE LEVER TO "ON" AFTER REFUELLING.

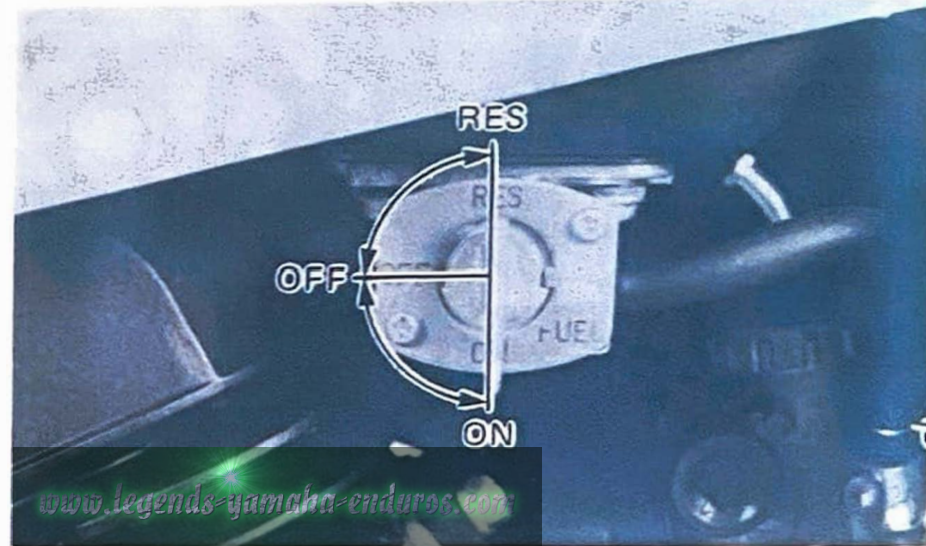

Starter knob (CHOKE)

Starting a cold engine requires a richer air-fuel mixture. A separate starter circuit supplies this mixture. Pull the starter knob out to open the circuit for starting. When the engine has warmed up, push the knob in to close the circuit.

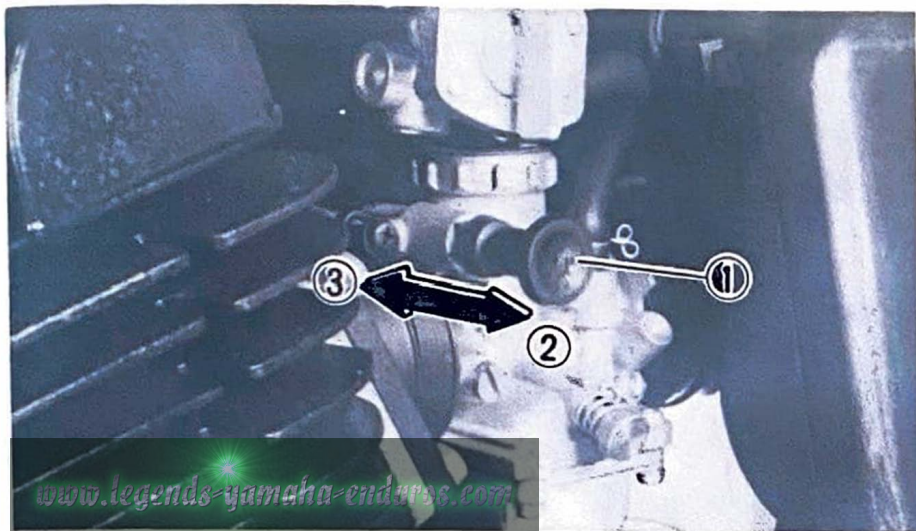

1. Starter knob (CHOKE)
2. Open the circuit
3. Close the circuit

EAC60201

Kick starter

Rotate the kick starter away from the engine. Push the starter down lightly with your foot until the gears engage, then kick smoothly and forcefully to start the engine. This model has a primary-coupled kick starter so the engine can be started in any gear if the clutch is disengaged. However, shifting to neutral before starting is recommended.

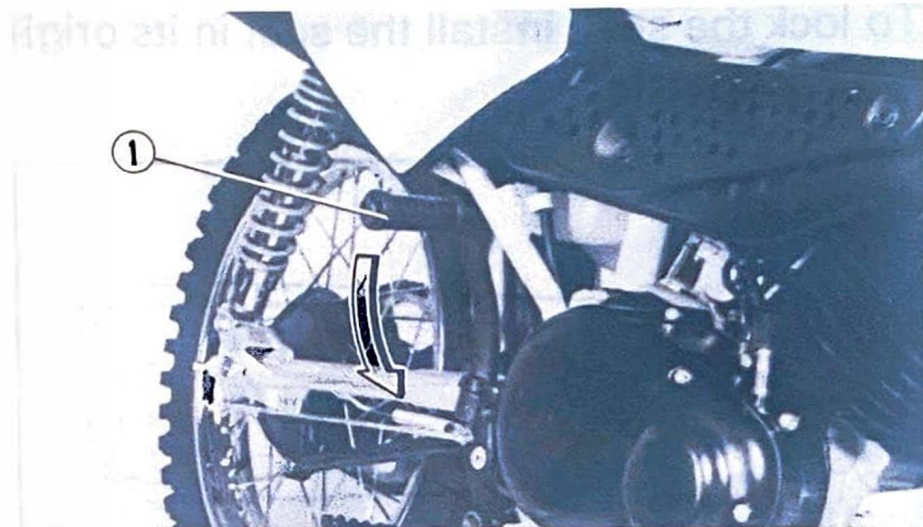

1. Kick starter

EAC41101

Seat

To open the seat, turn the knob as shown.

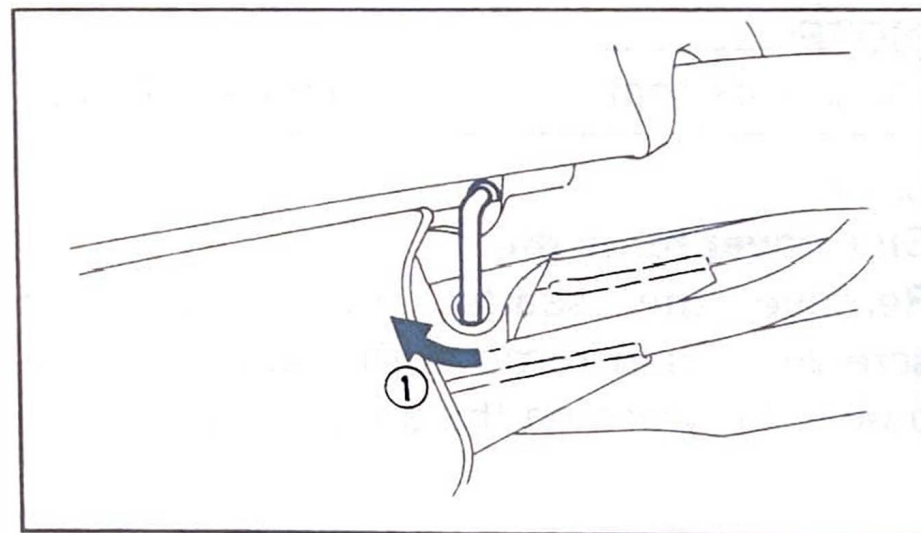

- 5-4 1. Open

To lock the seat, install the seat in its original position.

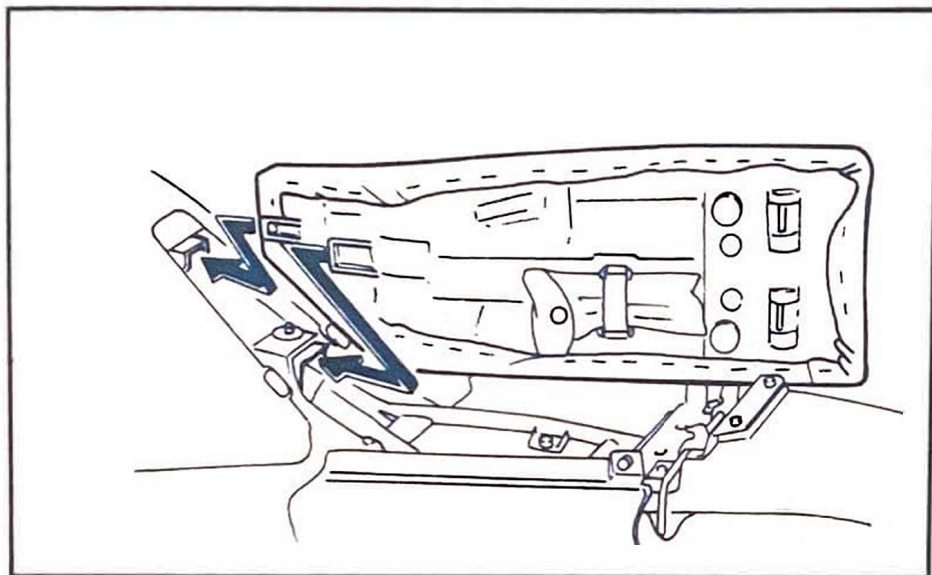

EUU01700

NOTE:

Make sure that the seat is securely fitted.

EAC70701

Side cover removal

Remove the seat(s) and side cover screw(s). Then remove the side cover by pulling outward on the areas as shown.

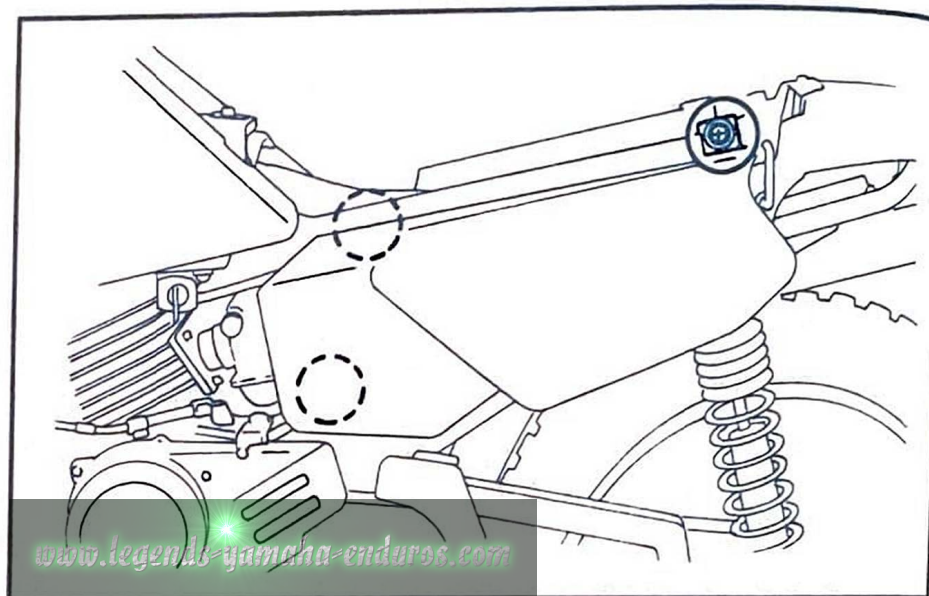

EAC90201

Rear shock absorber

The spring preload of the rear shock absorber can be adjusted to suit the rider's preference, machine's load (ex: optional accessories etc.) and road conditions. Refer to page 8-22 for proper adjustment procedures.

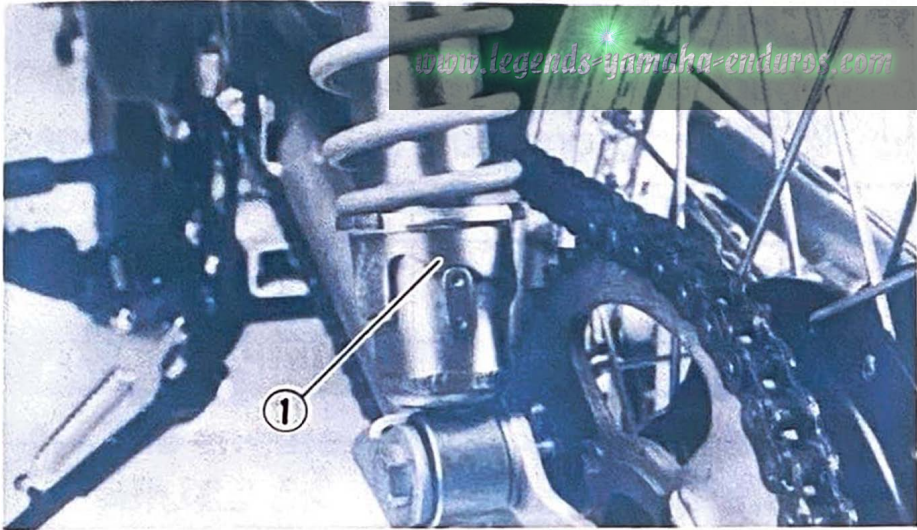

1. Adjuster

PRE-OPERATION CHECKS

Before using this machine, check the following points:

| Item | Routine | Page |
|-------------------------------|--|--------------------|
| Front and rear brakes | Check operation, condition and free play. Adjust if necessary. | 6-3, 8-13~8-15 |
| Clutch | Check operation, condition and free play. Adjust if necessary. | 6-3, 8-16 |
| Throttle grip/Housing | Check for smooth operation. Lubricate/Adjust if necessary. | 6-3, 8-13, 8-20 |
| Autolube tank | Check oil level/top-up as required. | 6-3~6-4, 8-20 |
| Transmission oil | Check oil level/top-up as required. | 6-4, 8-8~8-10 |
| Drive chain | Check chain slack and condition. Adjust if necessary. | 6-4, 8-17~8-19 |
| Wheels/Tires | Check tire pressure, wear and damage. | 6-4~6-7, 8-23~8-26 |
| Control cables | Check for smooth operation. Lubricate if necessary. | 8-20 |
| Brake and shift pedal shafts | Check for smooth operation. Lubricate if necessary. | 8-21 |
| Brake and clutch lever pivots | Check for smooth operation. Lubricate if necessary. | 8-21 |
| Sidestand pivot | Check for smooth operation. Lubricate if necessary. | 8-21 |
| Fittings/fasteners | Check all chassis fittings and fasteners. Tighten/Adjust, if necessary. | 6-7, 8-7 |
| Fuel tank | Check fuel level/top-up as required. | 6-8~6-9 |

NOTE:

Pre-operation checks should be made each time the machine is used. Such an inspection can be thoroughly accomplished in a very short time, and the added safety it assures is more than worth the time involved.

 WARNING

- 1. The engine, exhaust pipe(s), and muffler(s) will be very hot after the engine has been run. Be careful not to touch them or to allow any clothing item to contact them during inspection or repair.**
 - 2. If any item in the PRE-OPERATION CHECK is not working properly, have it inspected and repaired before operating the machine.**
-

EAE11401

Brakes (See page 8-13 for details)

1. Brake lever and brake pedal

Check for correct free play in the front brake lever and rear brake pedal and adjust if necessary. Make sure the brakes are working properly by checking at low speed shortly after starting out.

2. Check the brake shoes.

Refer to page 8-15.

EUU02101

NOTE:

When this brake service is necessary, consult a Yamaha dealer or other qualified mechanic.

EAE20000

Clutch (See page 8-16 for details)

Check the free play in the clutch lever, and make sure the lever operates properly. If the free play is incorrect, adjust it.

EAE30000

Throttle grip (See page 8-13 for details)

Turn the throttle grip to see if it operates properly, and check the free play. Make sure the grip returns by spring force when released. Ask a Yamaha dealer or other qualified mechanic to make any necessary adjustments.

EAE41301

Engine oil

Make sure the engine oil is at the specified level. Add oil as necessary.



1. Oil level window

2. Oil tank filler cap

Recommended oil:

Yamalube 2-cycle oil or
air-cooled 2-stroke engine oil

Oil quantity:

Total amount

1.0 L (0.88 Imp qt, 1.06 US qt)

EUU04201

NOTE:

Be sure the cap is properly seated when replacing.

EAE41900

Transmission oil (See page 8-8 for details)

Make sure the transmission oil is at the specified level. Add oil as necessary.

Recommended oil:

Yamalube 4 (10W30) or
SAE 10W30 type SE motor oil

Oil quantity:

Total amount:

0.7 L (0.62 Imp qt, 0.74 US qt)

Periodic oil change:

0.65 L (0.57 Imp qt, 0.69 US qt)

EAE50001

Chain (See page 8-17 for details)

Check the general condition of the chain and the chain slack before every ride. Lubricate and adjust the chain as necessary.

EAE96600

Tires

To ensure maximum performance, long service, and safe operation, note the following:

1. Tire air pressure

Always check and adjust the tire pressure before operating the machine.

⚠ WARNING

Tire inflation pressure should be checked and adjusted when the temperature of the tire equals the ambient air temperature.

| | Front | Rear |
|-----------------|---|---|
| Off-road riding | 125 kPa (1.25 kgf/cm ² , 18 psi) | 125 kPa (1.25 kgf/cm ² , 18 psi) |

2. Tire inspection

Always check the tires before operating the machine. If a tire tread shows crosswise lines (minimum tread depth), if the tire has a nail or glass fragments in it, or if the side wall is cracked, contact a Yamaha dealer or other qualified mechanic immediately and have the tire replaced.

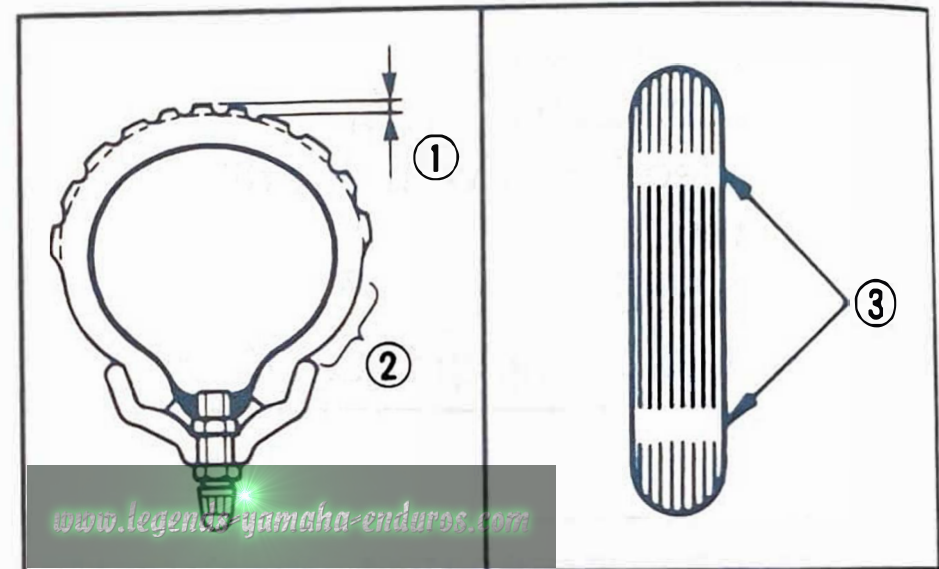

1. Tread depth 2. Side wall 3. Wear indicator

FRONT:

| Manufacture | Size | Type |
|-------------|-------------|--------|
| CHENG SING | 2.50-18 4PR | KNOBBY |

REAR:

| Manufacture | Size | Type |
|-------------|-------------|--------|
| CHENG SING | 3.00-16 4PR | KNOBBY |

| | |
|--|------------------|
| Minimum tire tread depth (front and rear) | 4.5 mm (0.18 in) |
|--|------------------|

⚠ WARNING

- 1. It is dangerous to ride with a worn-out tire. When a tire tread begins to show lines, have a Yamaha dealer or other qualified mechanic replace the tire immediately. Brakes, tires, and related wheel parts replacement should be left to a Yamaha Service Technician or other qualified mechanic.**
 - 2. Patching a punctured tube is not recommended. If it is absolutely necessary to do so, use great care and replace the tube as soon as possible with a good quality replacement.**
-

Wheels

To ensure maximum performance, long service, and safe operation, note the following:

- 1. Always inspect the wheels before a ride. Check for cracks, bends, or warpage of the wheel; be sure the spokes are tight and undamaged. If any abnormal condition exists in a wheel, consult a Yamaha dealer or other qualified mechanic. Do not attempt even small repairs to the wheel. If a wheel is deformed or cracked, it must be replaced.**
- 2. Tires and wheels should be balanced whenever either one is changed or replaced. Failure to have a wheel balanced can result in poor performance, adverse handling characteristics, and shortened tire life.**

3. After installing a tire, ride conservatively to allow the tire to seat itself on the rim properly. Failure to allow proper seating may cause tire failure, resulting in damage to the machine and injury to the rider.

EAE93900

Accessories or replacement parts

EUU69700

WARNING

This machine is not designed to pull a trailer or to be attached to a sidecar. The accessories or replacement parts you choose for your machine should be designed specifically for it, and they must be securely mounted to maintain the inherent stability of the original design. Genuine Yamaha Parts and Accessories are designed and tested to be compatible with your machine. Please consider Genuine Yamaha Parts and Accessories before making an accessory purchase. Use of

non-Yamaha-approved parts or accessories may cause loss of handling stability and riding safety. Since Yamaha cannot control the quality of parts or accessories manufactured by other companies, Yamaha cannot be held liable for any consequences caused by the use of items which have not been approved by Yamaha.

EAE85000

Fittings/Fasteners

Always check the tightness of chassis fittings and fasteners before a ride. Use the chart on page 8-7 to find the correct torque.

EAE71100

Switch

Check the operation of the "ENGINE STOP" switch.

Fuel

Make sure there is sufficient fuel in the tank.

! WARNING

Do not overfill the fuel tank. Avoid spilling fuel on the hot engine. Do not fill the fuel tank above the bottom of the filler tube as shown in the illustration or it may overflow when the fuel heats up later and expands.

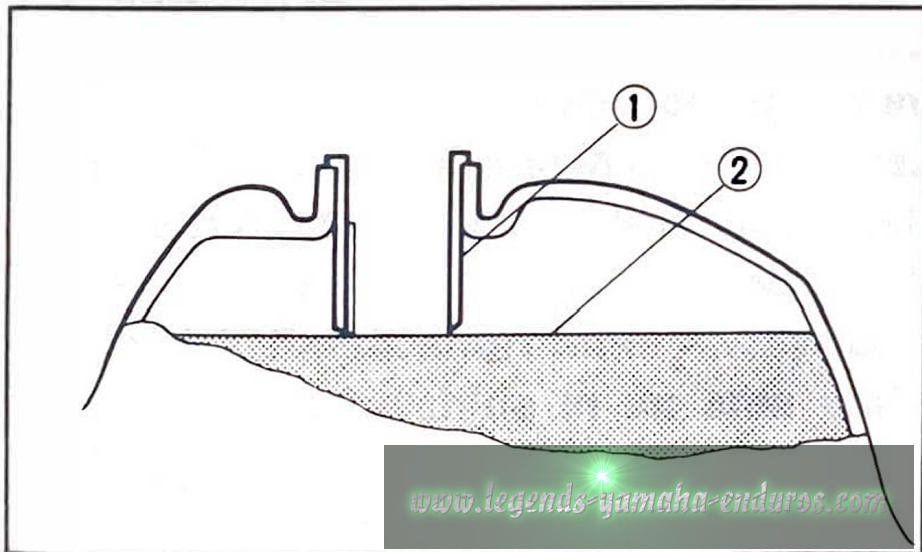

1. Filler tube

2. Fuel level

CAUTION

Always wipe off spilled fuel immediately with a dry and clean soft cloth. Fuel may deteriorate painted surfaces or plastic parts.

Recommended fuel:

UNLEADED FUEL

Fuel tank capacity:

Total:

5.0 L (1.1 Imp gal, 1.3 US gal)

Reserve:

1.5 L (0.3 Imp gal, 0.4 US gal)

Your Yamaha engine has been designed to use regular unleaded gasoline with a pump octane number ($(R+M)/2$) of 86 or higher, or research octane number of 91 or higher. If knocking or pinging occurs, use a different brand of gasoline or premium unleaded fuel. Unleaded fuel will give you longer spark plug life and reduced maintenance cost. If unleaded gasoline is not available, then leaded regular gasoline can be used.

Gasohol

There are two types of gasohol; gasohol containing ethanol and that containing methanol. Gasohol containing ethanol can be used if ethanol content does not exceed 10%. Gasohol containing methanol is not recommended by Yamaha because it can cause fuel system damage or vehicle performance problems.

OPERATION AND IMPORTANT RIDING POINTS

EUU72200

WARNING

This model is designed for off-road use only. In most instances, it is illegal to ride this model (either day or night) on any public street or highway.

EUU62800

WARNING

- 1. Never start your engine or let it run for any length of time in a closed area. The exhaust fumes are poisonous and can cause loss of consciousness and death within a short time. Always operate your machine in an area with adequate ventilation.**

- 2. Before starting out, always be sure the sidestand is up. Failure to retract the sidestand completely can result in a serious accident when you try to turn a corner.**

www.legends-yamaha-enduros.com

EAF12900

Starting and warming up a cold engine

- 1. Turn the fuel cock to "ON."**
- 2. Shift transmission into neutral.**
- 3. Fully open the starter (CHOKE), and completely close the throttle grip.**
- 4. Kick the kick starter to start the engine.**
- 5. After starting the engine, turn back the starter (CHOKE) to warming up position (about halfway).**

EUU02600

NOTE: _____
For maximum engine life, always warm up the engine before starting off. Never accelerate hard with a cold engine.

6. After warming up the engine, turn off the starter completely.

EUU02700

NOTE: _____
The engine is warm when it responds normally to the throttle with the starter turned off.

www.legends-yamaha-enduros.com

EAF10800

Starting a warm engine

The starter (CHOKE) is not required when the engine is warm.

EUU31400

CAUTION: _____

See "Break-in section" prior to operating the machine for the first time.

EAF20002

Shifting

The transmission lets you control the amount of power you have available at a given speed for starting, accelerating, climbing hills, etc. The use of the shift pedal is shown in the illustration. (Page 5-2)
To shift into NEUTRAL, depress the shift pedal repeatedly until it reaches the end of its travel (you will feel a stop when you are in first gear), then raise the pedal slightly.

EUU31501

CAUTION: _____

1. Do not coast for long periods with the engine off, and do not tow the machine a long distance. Even with gears in neutral, the transmission is only properly lubricated when the engine is running. Inadequate lubrication may damage the transmission.

2. **Always use the clutch when changing gears. The engine, transmission, and driveline are not designed to withstand the shock of forced shifting and can be damaged by shifting without using the clutch.**

EAF21200

To start out and accelerate:

1. Pull the clutch lever to disengage the clutch.
2. Shift into FIRST gear.
3. Open the throttle gradually and at the same time, release the clutch lever slowly.
4. Once the machine has reached a high enough speed to change gears, close the throttle and at the same time, quickly pull in the clutch lever.
5. Shift into SECOND gear. (Be careful not to shift into neutral.)

6. Open the throttle part way and gradually release the clutch lever.
7. Follow the same procedure when shifting to the next higher gear.

EAF21300

To decelerate:

1. Close the throttle and apply both the front and the rear brakes at the same time to slow the machine.
2. Downshift through the gears and when the machine is almost completely stopped, shift into neutral.

Engine break-in

There is never a more important period in the life of your machine than the period between zero and 20 hours of riding. For this reason we ask that you carefully read the following material. Because the engine is brand new, you must not put an excessive load on it for the first several hours of running. The various parts in the engine wear and polish themselves to the correct operating clearances. During this period, prolonged full throttle operation or any condition which might result in excessive heating of the engine must be avoided. However, momentary full throttle operation under load (2 ~ 3 seconds maximum) does not harm the engine. Each full throttle acceleration sequence should be followed with a substantial rest period for the engine by cruising at lower RPM's so the engine can cool down from the temporary build up of heat.

1. 0 ~ 10 hours:
Avoid continuous operation above half throttle. Stop the engine and let it cool for 5 to 10 minutes after every hour of operation. Vary the speed of the machine from time to time. Do not operate it at one set throttle position.
2. 10 ~ 20 hours:
Avoid prolonged operation above 3/4 throttle. Rev the machine freely through the gears, but do not use full throttle at any time.
3. After break-in
Avoid prolonged full-throttle operation. Vary speed occasionally.

EUU35600

CAUTION:

If any engine trouble should occur during the break-in period, consult a Yamaha dealer or other qualified mechanic immediately.

www.legends-yamaha-enduros.com

Parking

When parking the machine, stop the engine. Turn the fuel cock to "OFF" whenever the engine is stopped.

WARNING

www.legends-yamaha-enduros.com

The muffler and exhaust pipe are hot. Park the machine in a place where pedestrians or children are not likely to touch the machine. Do not park the machine on a slope or soft ground; the machine may overturn.

PERIODIC MAINTENANCE AND MINOR REPAIR

EAH00501

Periodic inspection, adjustment, and lubrication will keep your scooter in the safest and most efficient condition possible. Safety is an obligation of the scooter owner. The maintenance and lubrication schedule chart should be considered strictly as a guide to general maintenance and lubrication intervals. **YOU MUST TAKE INTO CONSIDERATION THAT WEATHER, TERRAIN, GEOGRAPHICAL LOCATIONS, AND A VARIETY OF INDIVIDUAL USES ALL TEND TO DEMAND THAT EACH OWNER ALTER THIS TIME SCHEDULE TO SHORTER INTERVALS TO MATCH THE ENVIRONMENT.** The most important points of scooter inspection, adjustment, and lubrication are explained in the following pages.

WARNING

If you are not familiar with machine service, this work should be done by a Yamaha dealer or other qualified mechanic.

www.legends-yamaha-enduros.com

Tool kit

The service information included in this manual is intended to provide you, the owner, with the necessary information for completing some of your own preventive maintenance and minor repairs. The tools provided in the owner's tool kit are to assist you in the performance of periodic maintenance. However, some other tools such as a torque wrench are also necessary to perform the maintenance correctly.

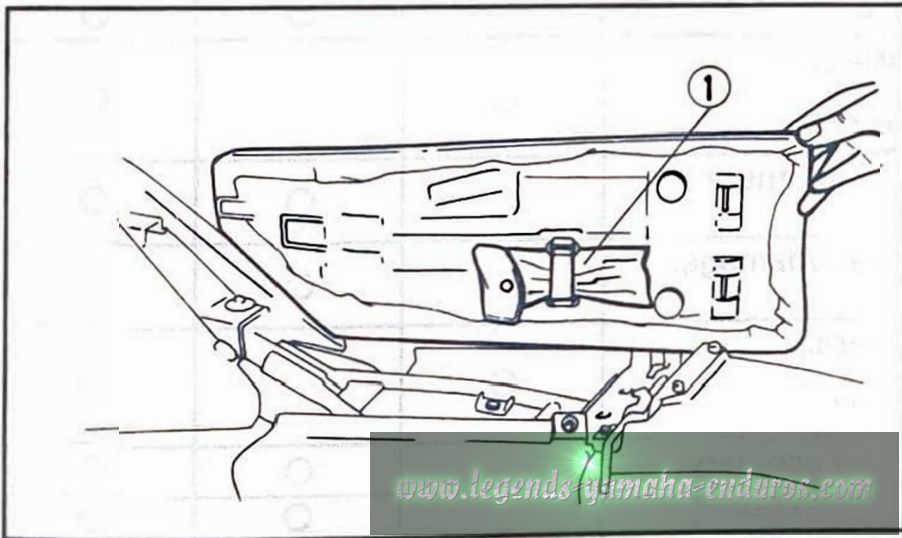

1. Tool kit

NOTE:

If you do not have necessary tools required during a service operation, take your machine to a Yamaha dealer or other qualified mechanic for service.

! WARNING

Modifications to this machine not approved by Yamaha may cause loss of performance, excessive emissions, and render it unsafe for use. Consult a Yamaha dealer or other qualified mechanic before attempting any changes.

PERIODIC MAINTENANCE / LUBRICATION

www.legends-yamaha-enduros.com

| Item | Remarks | BREAK-IN 1 month | EVERY | |
|----------------------|---|---------------------|----------|-----------|
| | | | 6 months | 12 months |
| Spark plug | Check condition. Clean or replace if necessary. | ○ | ○ | ○ |
| Air filter | Clean. Replace if necessary. | | ○ | ○ |
| Carburetor* | Check idle speed/starter operation. Adjust if necessary. | ○ | ○ | ○ |
| Fuel line* | Check fuel hose for cracks or damage. Replace if necessary. | | ○ | ○ |
| Transmission oil | Check oil level/oil leakage. Correct if necessary. Replace every 24 months. (Warm engine before draining) | REPLACE | ○ | ○ |
| Autolube pump* | Check operation. Correct if necessary. Air bleeding. | ○ | ○ | ○ |
| Brake | Check operation. Adjust if necessary. | | ○ | ○ |
| Clutch* | Check operation. Adjust if necessary. | | ○ | ○ |
| Rear arm pivot* | Check rear arm assembly for looseness. Correct if necessary. Moderately repack every 24 months.*** | ○ | | ○ |
| Wheels* | Check balance/damage/runout/spoke tightness. Repair if necessary. | | ○ | ○ |
| Wheel bearings* | Check bearings assembly for looseness/damage. Replace if damaged. | | ○ | ○ |
| Steering bearing* | Check bearings assembly for looseness. Correct if necessary. Moderately repack every 24 months.** | ○ | | ○ |
| Front forks* | Check operation/oil leakage. Repair if necessary. | | ○ | ○ |
| Rear shock absorber* | Check operation/oil leakage. Repair if necessary. | | ○ | ○ |

| Item | Remarks | BREAK-IN 1 month | EVERY | |
|---------------------|--|--|----------|-----------|
| | | | 6 months | 12 months |
| Drive chain | Check chain slack/alignment. Adjust if necessary. Clean and lube. | Every Ride (More often in wet or dusty areas) | | |
| Fittings/Fasteners* | Check all chassis fittings and fasteners. Correct if necessary. | ○ | ○ | ○ |
| Sidestand* | Check operation. Repair if necessary. | ○ | ○ | ○ |

* : It is recommended that these items be serviced by a Yamaha dealer or other qualified mechanic.

** : Medium weight wheel bearing grease.

*** : Lithium soap base grease.

Spark plug inspection

The spark plug is an important engine component and is easy to inspect. The condition of the spark plug can indicate the condition of the engine. The ideal color on the white porcelain insulator around the center electrode is a medium to light tan color for a machine that is being ridden normally. Do not attempt to diagnose any problems yourself. Instead, take the machine to a Yamaha dealer or other qualified mechanic. You should periodically remove and inspect the spark plug because heat and deposits will cause the spark plug to slowly break down and erode. If electrode erosion becomes excessive, or if carbon and other deposits are excessive, you should replace the spark plug with the specified plug.

Standard spark plug:
B7ES (NGK)

Before installing the spark plug, measure the electrode gap with a wire thickness gauge; adjust the gap to specification as necessary.

Spark plug gap:
0.5 ~ 0.6 mm (0.020 ~ 0.024 in)

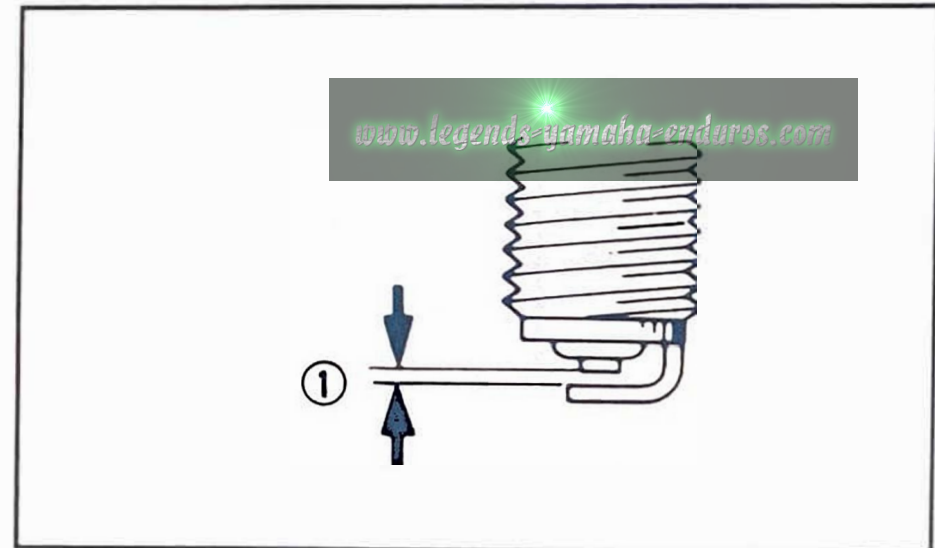

1. Spark plug gap

When installing the plug, always clean the gasket surface and use a new gasket. Wipe off any grime from the threads, and torque the spark plug properly.

Spark plug torque:
25 Nm (2.5 m·kg, 18 ft·lb)

EUU03801

NOTE:

If a torque wrench is not available when you are installing a spark plug, a good estimate of the correct torque is 1/4 to 1/2 turn past finger tight. Have the spark plug torqued to the correct value as soon as possible with a torque wrench.

www.legends-yamaha-enduros.com

Torque specifications

(For a more complete list, refer to the Service Manual for this model.)

Use a torque wrench to tighten these items. It is recommended that these items be checked occasionally, especially before a long trip.

Always check the tightness of these items whenever they are loosened for any reason.

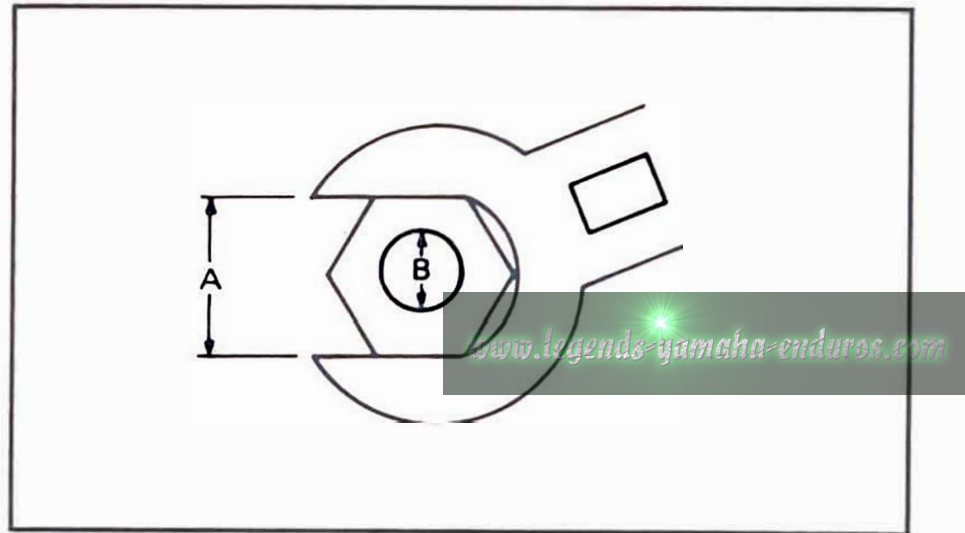

| A (Nut) | B (Bolt) | General torque specifications | | |
|------------|-------------|-------------------------------|------|-------|
| | | Nm | m·kg | ft·lb |
| 10 mm | 6 mm | 6 | 0.6 | 4.3 |
| 12 mm | 8 mm | 15 | 1.5 | 11 |
| 14 mm | 10 mm | 30 | 3.0 | 22 |
| 17 mm | 12 mm | 55 | 5.5 | 40 |
| 19 mm | 14 mm | 85 | 8.5 | 61 |
| 22 mm | 16 mm | 130 | 13.0 | 94 |

| Item | Torque | | |
|--------------------|--------|------|-------|
| | Nm | m·kg | ft·lb |
| Spark plug | 25 | 2.5 | 18 |
| Engine drain plug | 20 | 2.0 | 14 |
| Front wheel axle | 43 | 4.3 | 31 |
| Rear wheel axle | 39 | 3.9 | 28 |
| Tension bar bolt | 18 | 1.8 | 13 |
| Sprocket shaft nut | 85 | 8.5 | 61 |

Transmission oil

1. Oil level measurement
 - a. Place the machine on a level place and hold it in an upright position. Warm up the engine for several minutes.

EUU03901

NOTE:

Be sure the machine is positioned straight up when checking the oil level. A slight tilt toward the side can result in false readings.

- b. With the engine stopped, unscrew the oil filler cap/dipstick and rest it on the threads of the oil filler hole.

EUU04000

NOTE:

Wait a few minutes until the oil level settles before checking.

- c. The oil level should be between the maximum and minimum level as shown. If the level is low, add sufficient oil to raise it to the proper level.

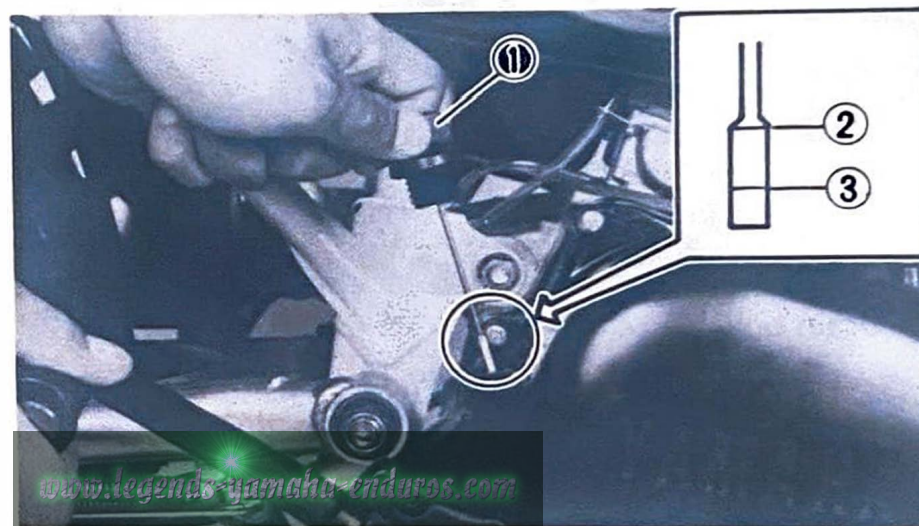

1. Dipstick
2. Maximum level
3. Minimum level

2. Transmission oil replacement

- a. Warm up the engine for several minutes.
- b. Stop the engine. Place an oil pan under the engine, and remove the oil filler cap/dipstick.
- c. Remove the drain bolt and drain the oil.

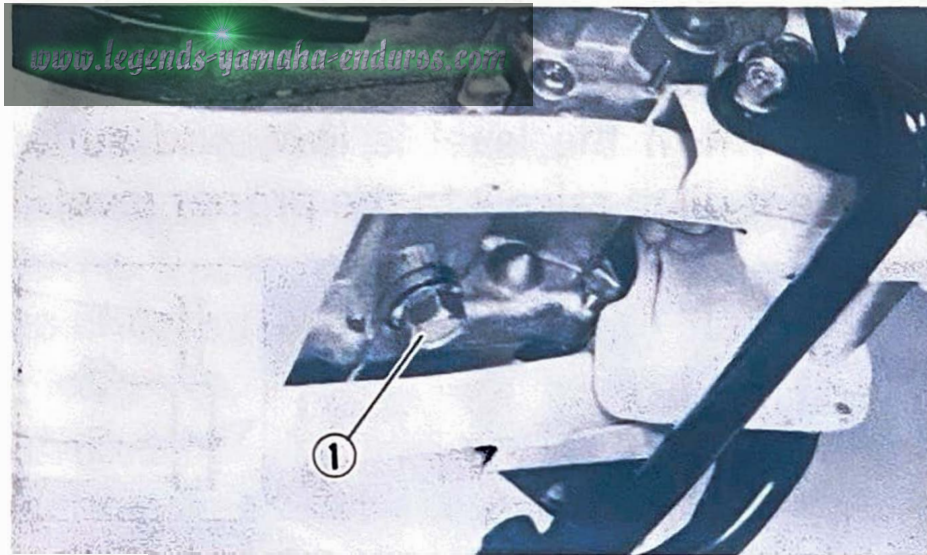

1. Drain bolt

d. Reinstall the drain bolt (make sure it is tight).

Drain bolt torque:

20 Nm (2.0 m·kg, 14 ft·lb)

e. Fill engine with oil. Install the oil filler cap/dipstick and tighten.

Recommended oil:

Yamalube 4 (10W30) or
SAE 10W30 type SE motor oil

Oil quantity:

Total amount:

0.7 L (0.62 Imp qt, 0.74 US qt)

Periodic oil change:

0.65 L (0.57 Imp qt, 0.69 US qt)

EUU34901

CAUTION:

Do not put in any chemical additives. Transmission oil also lubricates the clutch and additives could cause clutch slippage.

EUU32400

CAUTION:

Be sure no foreign material enters the crankcase.

f. Start the engine and warm up for a few minutes. While warming up, check for oil leakage. If oil leakage is

found, stop the engine immediately, and check for cause.

EAH67900

Air filter

The element should be cleaned at the specified intervals. It should be cleaned more frequently you are riding in unusually wet or dusty areas.

1. Remove the seat.
2. Remove the side cover.
3. Remove the air filter case fitting screws and the filter case cover.

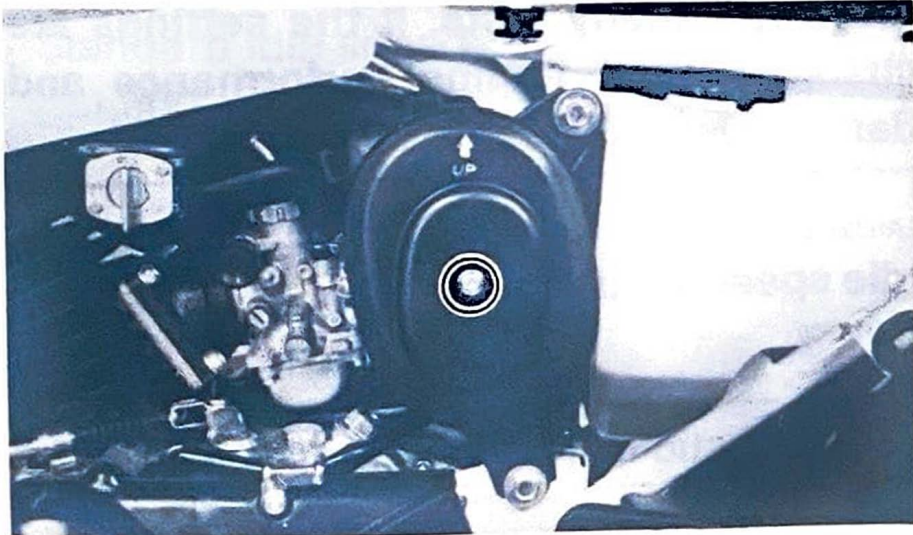

4. Remove the element from its case, and clean it with solvent. After cleaning, remove the remaining solvent by squeezing the element.

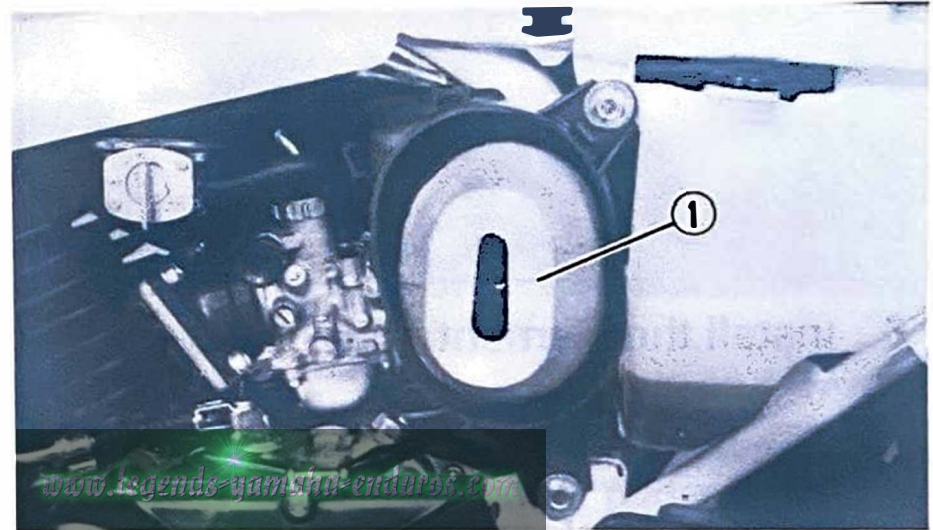

1. Air filter element

5. Apply recommended oil to the entire surface of the filter and squeeze out the excess oil. The element should be wet but not dripping.

Recommended oil:

Yamaha foam air filter oil or
other quality air filter oil

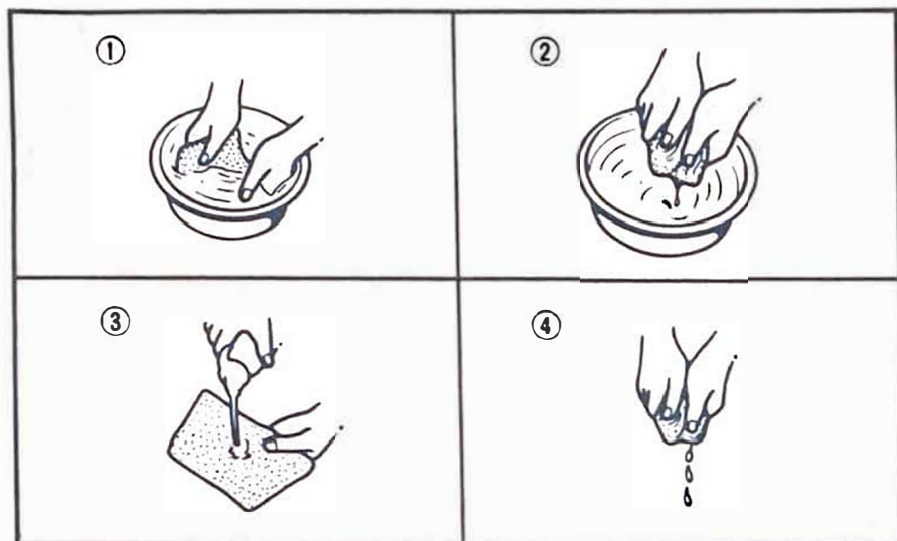

6. Install the element in its case.

EUU35701

CAUTION:

Make sure the element is properly seated in the filter case.

EUU42400

CAUTION:

The engine should never be run without the air filter element installed; excessive piston and/or cylinder wear may result.

EAH92500

Carburetor adjustment

The carburetor is a vital part of the engine and requires very sophisticated adjustment. Most adjustments should be left to a Yamaha dealer or other qualified mechanic who has the professional knowledge and experience to do so. However, the following may be serviced by the owner as part of routine maintenance.

EUU33001

CAUTION:

The carburetor was set at the Yamaha factory after many tests. If the settings are changed, poor engine performance and damage may result.

EAH92400

Idle speed adjustment

EUU13700

NOTE:

A diagnostic tachometer must be used for this procedure.

1. Attach the tachometer. Start the engine and warm it up for a few minutes (normally, 1 or 2 minutes) at approximately 1,000 to 2,000 r/min. Occasionally rev the engine to 4,000 to 5,000 r/min. The engine is warm when it quickly responds to the throttle.
2. Set the idle to the specified engine speed by adjusting the throttle stop screw; turn the screw in to increase engine speed, and out to decrease engine speed.

Standard idle speed:
1,300 ~ 1,450 r/min

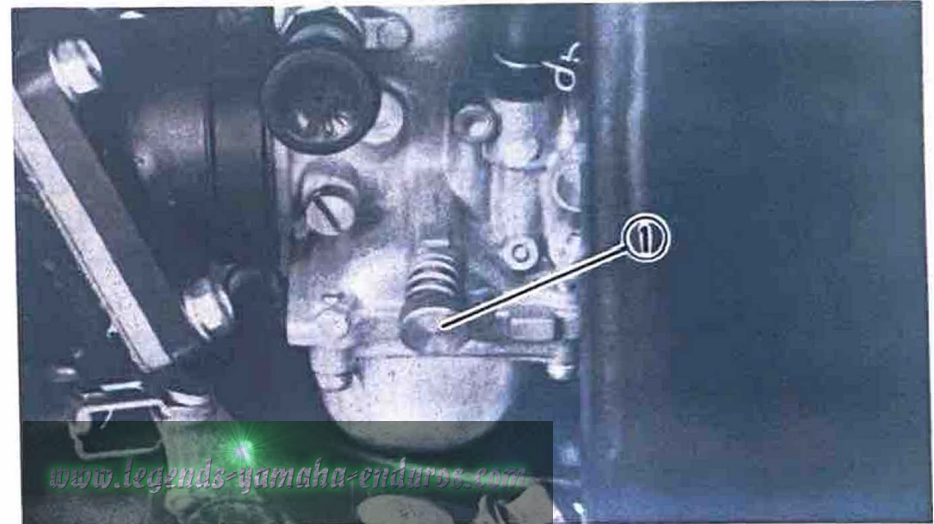

1. Throttle stop screw

EUU11700

NOTE:

If the specified idle speed cannot be obtained by performing the above adjustment, consult a Yamaha dealer or other qualified mechanic.

Throttle cable adjustment

EUU06400

NOTE:

Before adjusting the throttle cable free play, the engine idling speed should be adjusted.

Adjust the throttle cable by turning the adjuster so that proper free play at the throttle grip is obtained.

Free play:

3 ~ 5 mm (0.12 ~ 0.20 in)

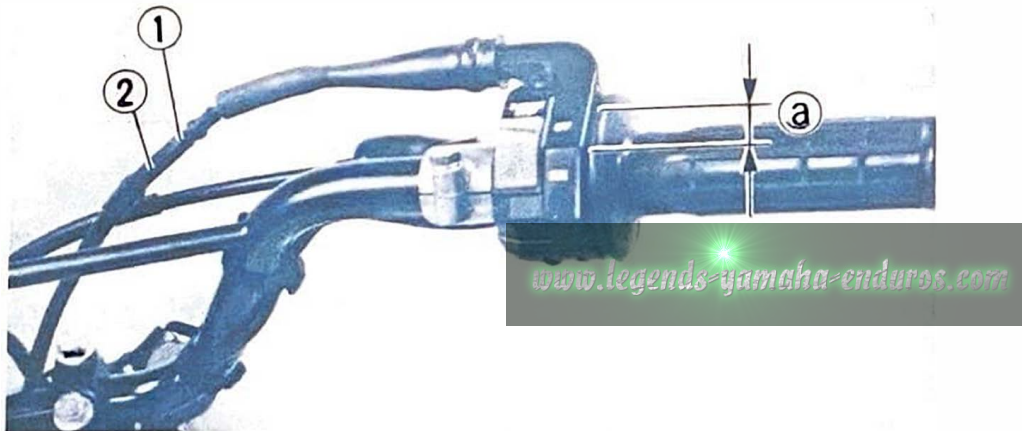

1. Lock nut

2. Adjuster

a. Free play

1. Loosen the lock nut.
2. Turn the adjuster in or out until specified free play is obtained.
3. Tighten the lock nut.

EAH83802

Front brake adjustment

The front brake lever free play should be adjusted to 5 ~ 8 mm (0.2 ~ 0.3 in) at the brake lever pivot. Adjustment can be made at either the handlebar lever holder or the front brake hub.

1. Loosen the lock nut.
2. Turn the cable length adjuster in or out until specified free play is obtained.
3. Tighten the lock nut.

! WARNING

When it is impossible to make the proper adjustment, ask a Yamaha dealer or other qualified mechanic.

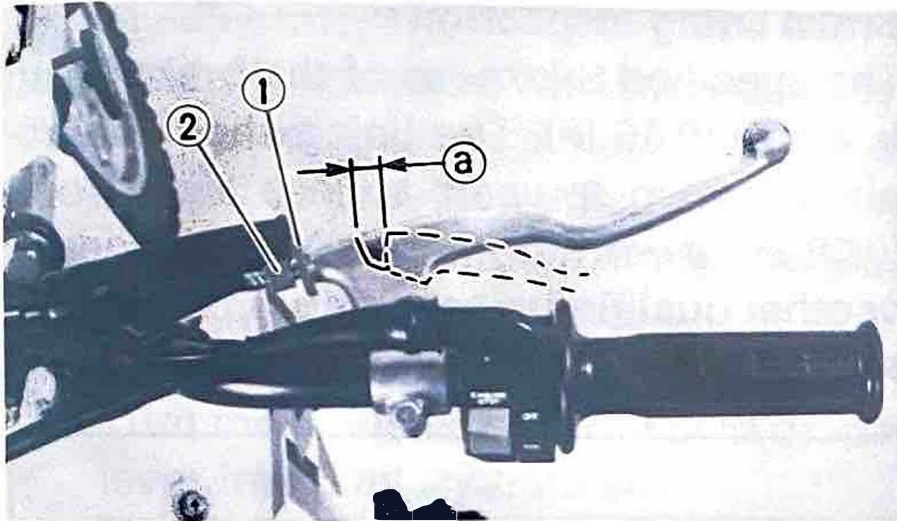

1. Lock nut
2. Adjuster
a. 5 ~ 8 mm (0.2 ~ 0.3 in)

Rear brake adjustment

The rear brake pedal free play should be adjusted to 20 ~ 30 mm (0.8 ~ 1.2 in) at the brake pedal end. To adjust, turn the adjuster clockwise to reduce play or counterclockwise to increase play.

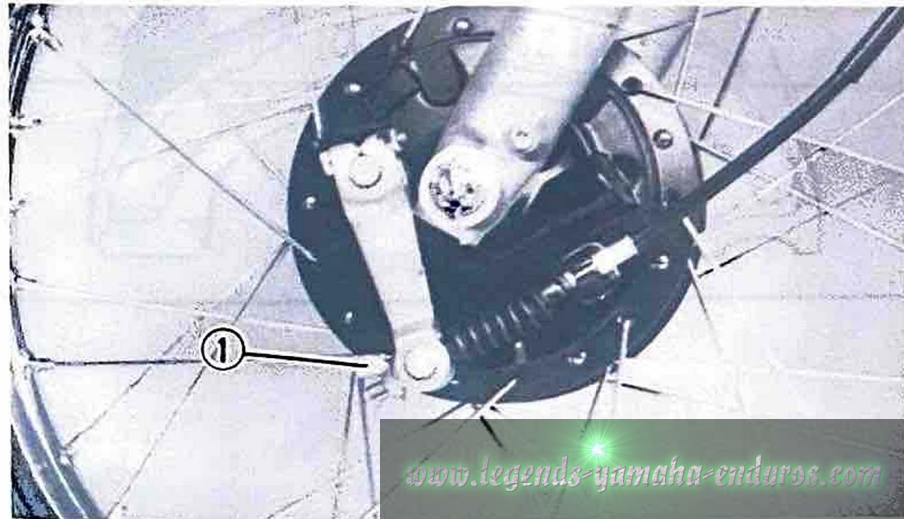

1. Adjuster

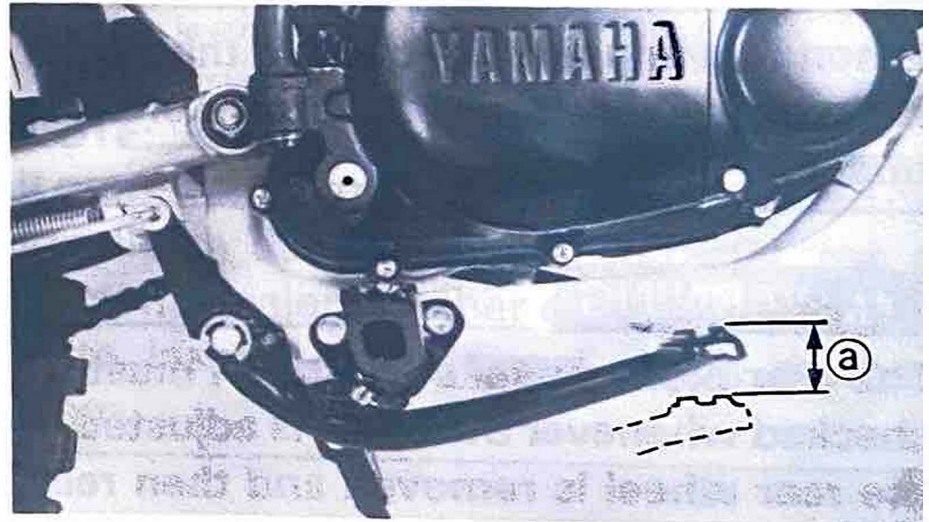

a. Free play 20 ~ 30 mm (0.8 ~ 1.2 in)

Brake lining inspection

The specified thickness of the brake lining is 4 mm (0.16 in). The lining should be replaced when it wears to less than 2 mm (0.08 in). If worn out, ask a Yamaha dealer or other qualified mechanic to install a new set.

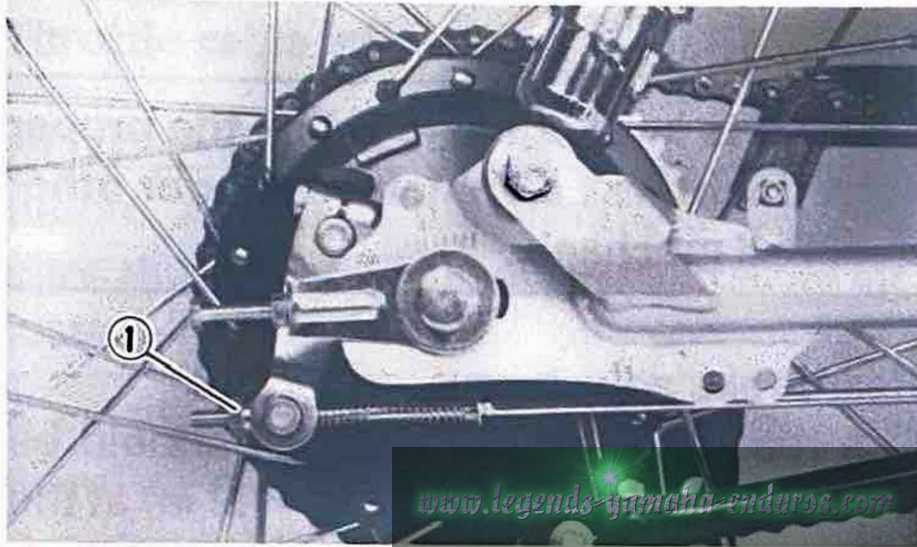

1. Adjuster

! WARNING

When it is impossible to make the proper adjustment, ask a Yamaha dealer or other qualified mechanic.

! WARNING

The rear brake pedal adjustment must be checked whenever the chain is adjusted or the rear wheel is removed and then reinstalled.

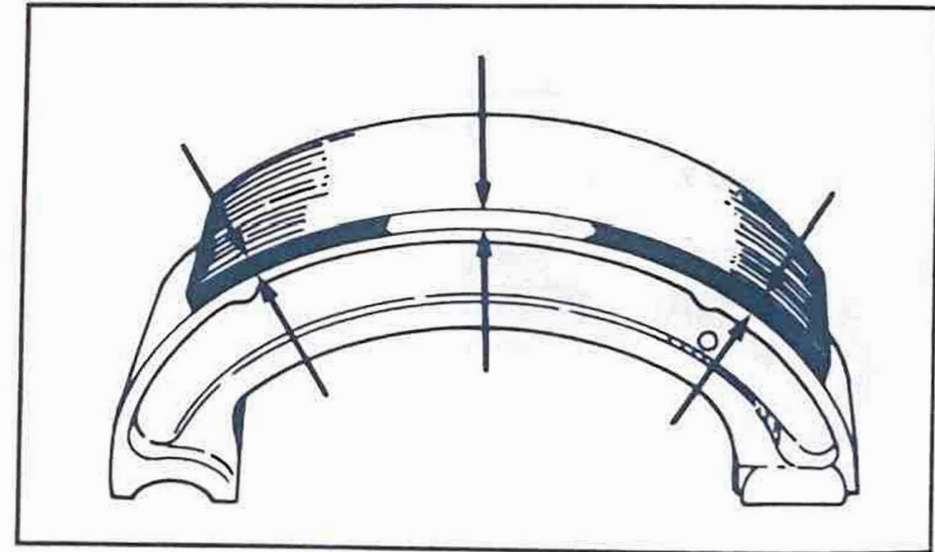

Clutch adjustment

This model is equipped with two adjusters. They are used to take up slack from cable stretch and to provide sufficient free play for proper clutch operation. If the free play is incorrect, adjust as follows.

1. Loosen the lock nut.
2. Turn the adjuster in or out until proper lever free play is obtained.
3. Tighten the lock nut.

Clutch lever freeplay

2 ~ 3 mm (0.08 ~ 0.12 in)

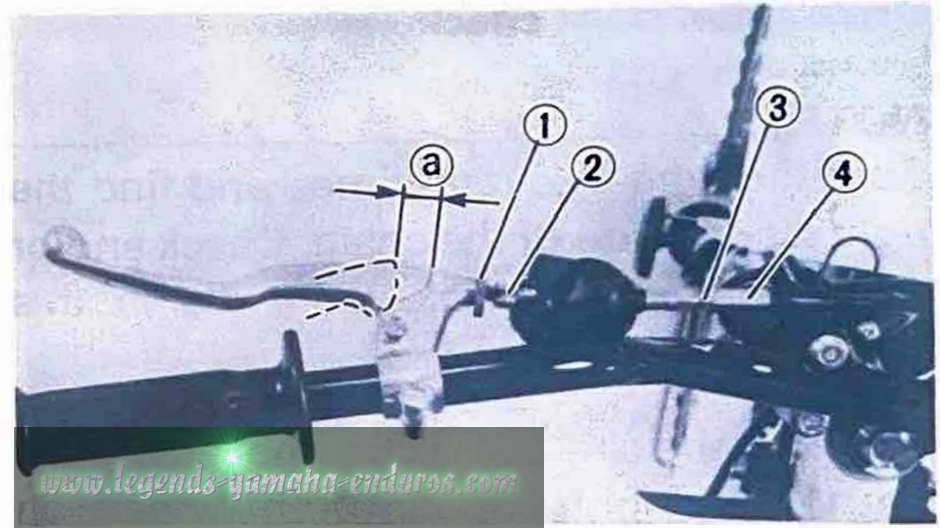

1. Clutch lever adjuster lock nut
2. Clutch lever adjuster
3. Cable adjuster lock nut
4. Cable adjuster
- a. Clutch lever free play

EUU18200

NOTE:

If proper adjustment cannot be obtained or the clutch does not work correctly, ask a Yamaha dealer or other qualified mechanic to inspect the internal clutch mechanism.

EAI40801

Drive chain slack check

EUU04801

NOTE:

Spin the wheel several times and find the tightest position of the chain. Check and/or adjust the chain slack while it's in this tightest position.

To check the chain slack the machine must be held straight up with both wheels on the ground and without rider. Check the slack at the position shown in the illustration. Normal slack is approximately 20 ~ 30 mm (0.8 ~ 1.2 in). If the slack exceeds 30 mm (1.2 in), adjust.

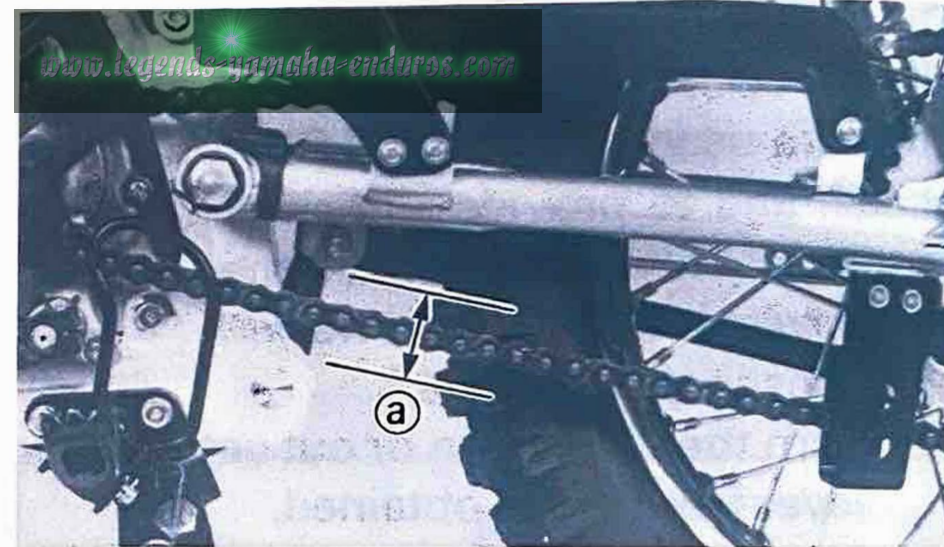

a. 20 ~ 30 mm (0.8 ~ 1.2 in)

EAI42600

Drive chain slack adjustment

1. Loosen the rear brake adjuster.

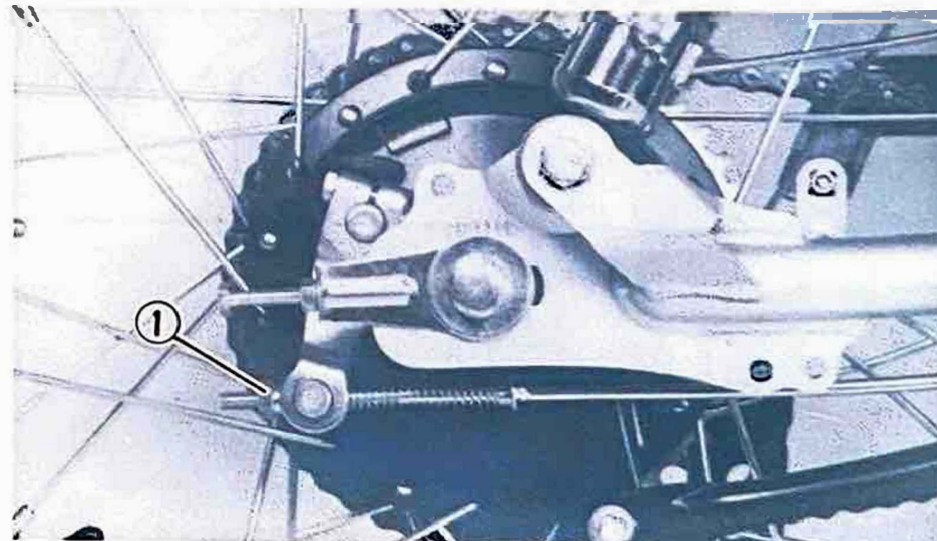

8-17 1. Rear brake adjuster

2. Remove the cotter pin from the axle nut.
3. Loosen the axle nut.
4. Loosen the sprocket shaft nut and lock nuts on each side. To tighten the chain, turn the chain adjuster clockwise. To loosen the chain, turn the adjuster counterclockwise and push the wheel forward. Turn each adjuster exactly the same amount to maintain correct axle alignment. There are marks on each side of the swingarm and a match mark on each chain puller. Use these marks to align the rear wheel.

EUU33301

CAUTION:

Too little chain slack will overload the engine and other vital parts. Keep the slack within the specified limits.

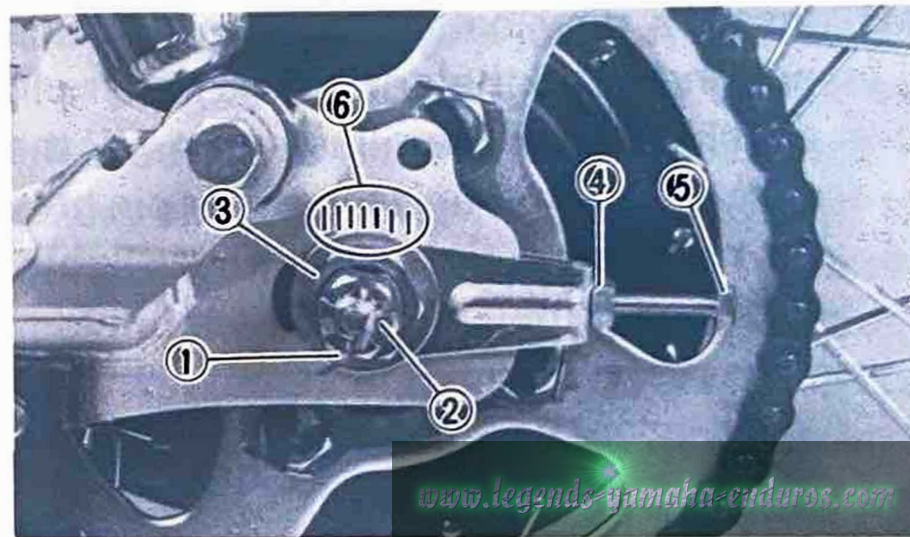

- | | | |
|---------------|-------------|-----------------------|
| 1. Cotter pin | 2. Axle nut | 3. Sprocket shaft nut |
| 4. Lock nut | 5. Adjuster | 6. Alignment marks |

5. After adjusting, be sure to tighten the loosened parts.

Tightening torque:

Axle nut:

39 Nm (3.9 m·kg, 28 ft·lb)

Sprocket shaft nut:

85 Nm (8.5 m·kg, 61 ft·lb)

6. Insert a new cotter pin into the axle nut and bend the end of the cotter pin as shown in the illustration. If the notch in the nut and the cotter pin hole do not match, tighten the nut slightly to align them.

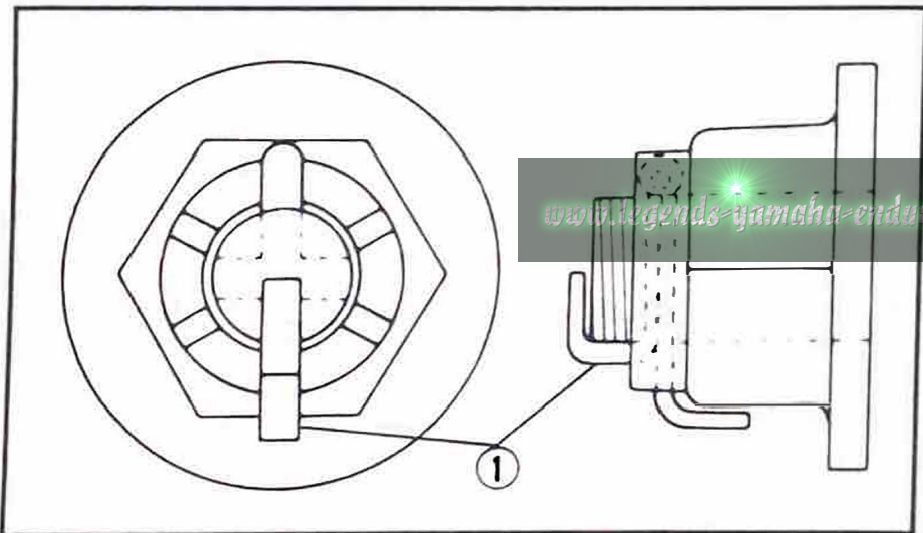

1. Cotter pin

EUU64700

! WARNING

Always use a new cotter pin on the axle nut.

Drive chain lubrication

The chain consists of many parts which work with each other. If the chain is not maintained properly, it will wear out quickly. Therefore, the chain must be serviced regularly. This service is especially necessary when riding in dusty areas.

1. Use Yamaha Chain and Cable Lube or any brands of spray-type chain lubricant. First, remove all dirt and mud from the chain with a brush or cloth, then spray lubricant between both rows of side plates and on all center rollers. The chain should be lubricated every 500 km (300 mi).
2. To clean the chain, remove it from the machine, dip it in solvent, and clean out as much dirt as possible. Take the chain out of the solvent and dry it. Immediately lubricate the chain to prevent it from rusting.

7. Adjust the free play in the brake pedal.

Cable inspection and lubrication

EUJ64601

WARNING

Damage to the outer housing of cables may allow internal rusting and cause interference with cable movement. Replace damaged cables as soon as possible to prevent unsafe conditions.

Lubricate the inner cable and the cable end. If it does not operate smoothly, ask a Yamaha dealer or other qualified mechanic to replace.

Recommended lubricant:
Yamaha Chain and Cable Lube or
SAE 10W30 motor oil

www.legends-yamaha-enduros.com

Throttle cable and grip lubrication

The throttle twist grip assembly should be greased at the time that the cable is lubricated, since the grip must be removed to get at the end of the throttle cable. After removing the screws, hold the end of the cable up in the air and put in several drops of lubricant. With the throttle grip disassembled, coat the metal surface of the grip assembly with a suitable all-purpose grease.

Autolube pump adjustment

The autolube pump is a vital part of the engine and requires very sophisticated adjustment. Adjusting should be left to a Yamaha dealer who has the professional knowledge and experience to do so.

EAI30201

Brake and shift pedals

Lubricate the pivoting parts.

Recommended lubricant:
Yamaha Chain and Cable Lube or
SAE 10W30 motor oil

EAI30300

Brake and clutch levers

Lubricate the pivoting parts.

Recommended lubricant:
Yamaha Chain and Cable Lube or
SAE 10W30 motor oil

EAI31001

Sidestand

Lubricate the pivoting parts. Check to see that the sidestand moves up and down smoothly.

Recommended lubricant:
Yamaha Chain and Cable Lube or
SAE 10W30 motor oil

EUU70101

WARNING

If the sidestand does not move smoothly, consult a Yamaha dealer or other qualified mechanic.

EAI31300

Rear suspension

Lubricate the pivoting parts.

Recommended lubricant:
Lithium soap base grease

EAI20601

Front fork inspection

EUU65700

WARNING

www.legends-yamaha-enduros.com

Securely support the machine so there is no danger of it falling over.

1. Visual check
Check for scratches/damage on the inner tube and excessive oil leakage from the front fork.

2. Operation check

Place the machine on a level place.

- Hold the machine in an upright position and apply the front brake.
- Stroke the front forks up and down several times.

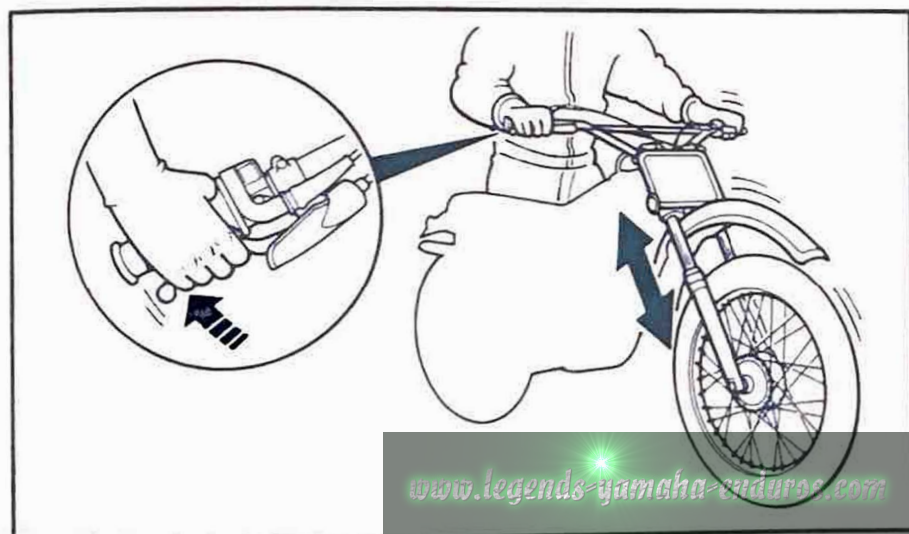

EUU42600

CAUTION:

If any damage or unsmooth movement is found with the front fork, consult a Yamaha dealer or other qualified mechanic.

EAI50901

Rear shock absorber adjustment

This shock absorber is equipped with a spring preload adjuster.

Adjust spring preload as follows.

Turn adjuster in direction ② to increase spring preload and in direction ① to decrease spring preload.

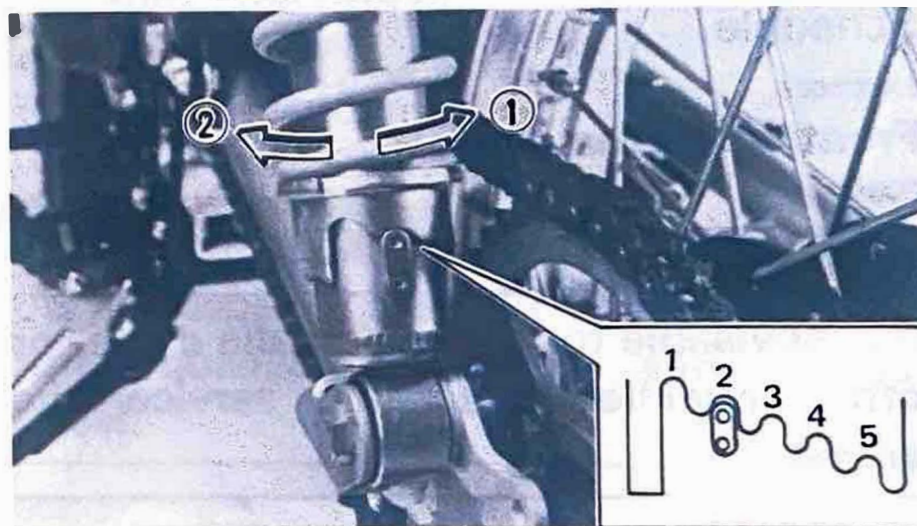

1. Decrease

2. Increase

EUU65200

! WARNING

Always adjust each shock absorber to the same setting. Uneven adjustment can cause poor handling and loss of stability.

Wheel bearings

If there is play in the front or rear wheel hub or if the wheel does not turn smoothly, have a Yamaha dealer or a qualified mechanic inspect the wheel bearings. The wheel bearings should be inspected according to the General Maintenance Schedule.

Front wheel removal

⚠ WARNING

It is advisable to have a Yamaha dealer or other qualified mechanic service the wheel.

⚠ WARNING

Securely support the machine so there is no danger of it falling over.

1. Remove the brake cable; loosen all cable adjusters and remove the cable from the handlebar lever holder. Then remove the cable from the cam lever at the front wheel hub.
2. Remove the cotter pin and axle nut.
3. Elevate the front wheel by placing a suitable stand under the engine.

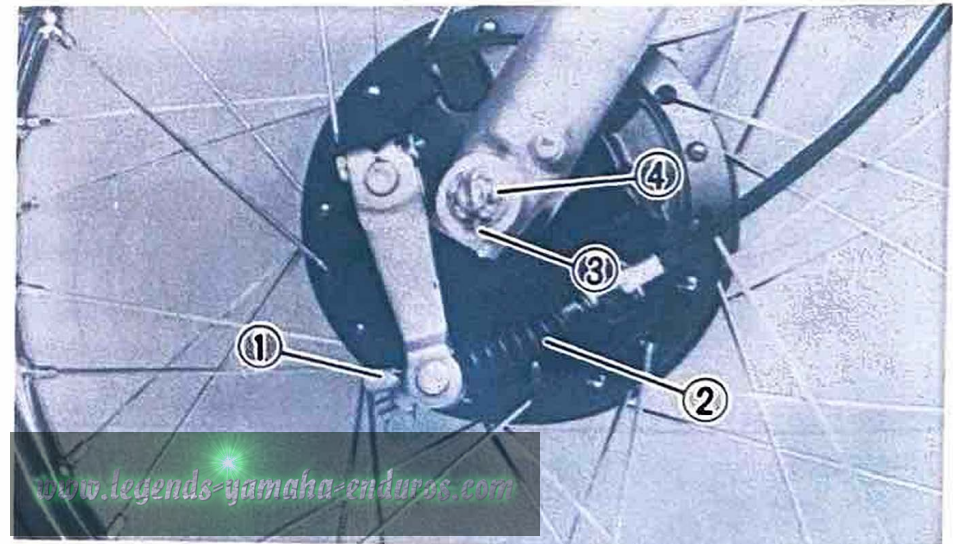

- | | |
|-------------------|----------------|
| 1. Cable adjuster | 2. Brake cable |
| 3. Cotter pin | 4. Axle nut |
4. Remove the wheel axle. Make sure the machine is properly supported.

Front wheel installation

When installing the front wheel, reverse the removal procedure. Pay attention to the following points:

1. Make sure the slot in the brake shoe plate fits over the stopper on the front fork outer tube.

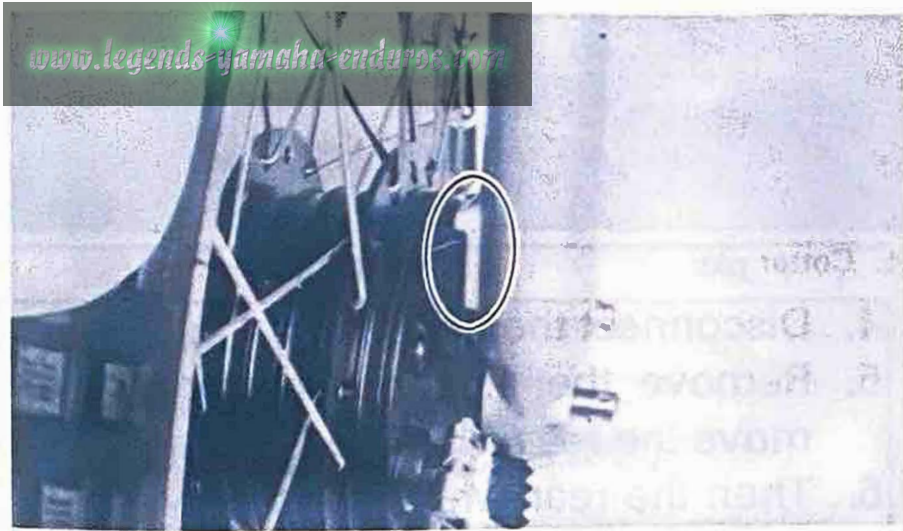

2. Make sure the axle nut is properly torqued, and a new cotter pin is installed.

EUU78000

⚠ WARNING

Always use a new cotter pin.

Axle nut torque:
43 Nm (4.3 m·kg, 31 ft·lb)

3. Adjust the free play in the brake lever.

EAJ36301

Rear wheel removal

EUU66101

⚠ WARNING

It is advisable to have a Yamaha dealer or other qualified mechanic service the wheel.

EUU65700

⚠ WARNING

Securely support the machine so there is no danger of it falling over.

1. Elevate the rear wheel by placing a suitable stand under the engine.
2. Remove the cotter pin, nut and tension bar bolt from the brake shoe plate.

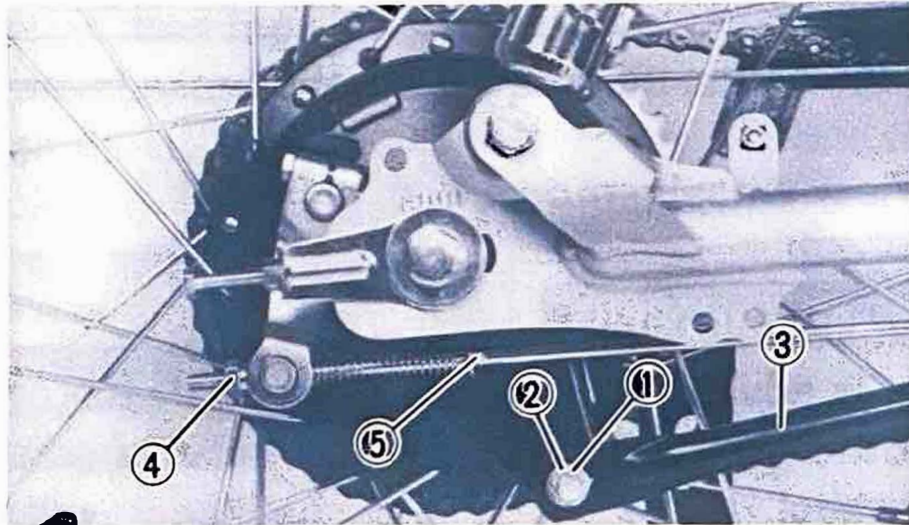

- | | | |
|---------------|--------------|----------------|
| 1. Cotter pin | 2. Nut | 3. Tension bar |
| 4. Adjuster | 5. Brake rod | |

3. Remove the brake adjuster and brake rod from the brake cam lever.

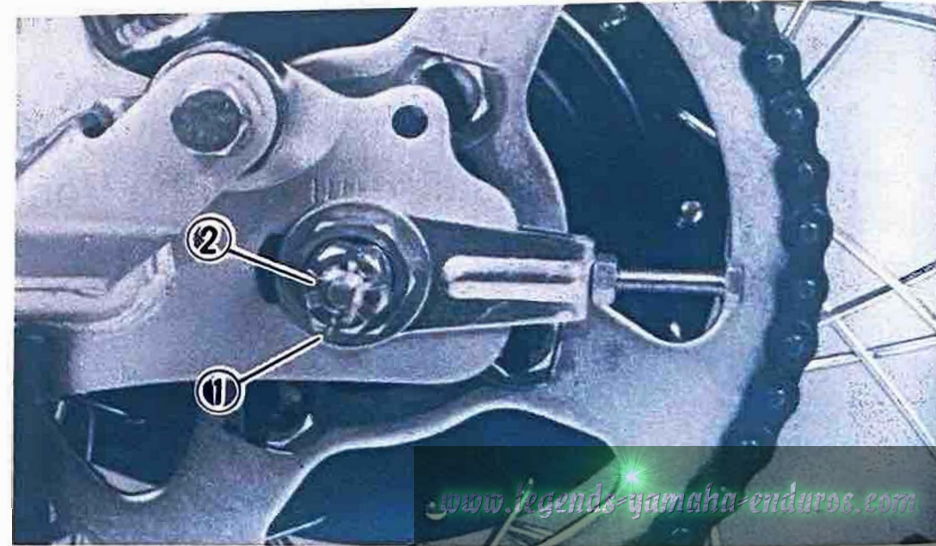

- | | |
|---------------|-------------|
| 1. Cotter pin | 2. Axle nut |
|---------------|-------------|
4. Disconnect the drive chain.
 5. Remove the axle nut cotter pin remove the rear wheel axle nut.
 6. Then the rear wheel assembly, collar, chain puller(s), etc., can be removed from the machine by pulling out the wheel axle.

Rear wheel installation

When installing the rear wheel, reverse the removal procedure.

Pay attention to the following points:

1. Adjust the drive chain.
2. Make sure the following parts are properly torqued, and a new cotter pin is installed.

EUU78000

WARNING

Always use a new cotter pin.

Tightening torque:

Axle nut:

39 Nm (3.9 m·kg, 28 ft·lb)

Tension bar bolt:

18 Nm (1.8 m·kg, 13 ft·lb)

3. Adjust the rear brake. (See page 8-14.)

EAJ50002

Troubleshooting

Although Yamaha machines receive a rigid inspection before shipment from the factory, trouble may occur during operation.

Any problem in the fuel, compression, or ignition systems can cause poor starting and loss of power. The troubleshooting chart describes a quick, easy procedure for making checks.

If your machine requires any repair, bring it to a Yamaha dealer. The skilled technicians at a Yamaha dealership have the tools, experience, and know-how to properly service your machine. Use only genuine Yamaha parts on your machine. Imitation parts may look like Yamaha parts, but they are often inferior. Consequently, they have a shorter service life and can lead to expensive repair bills.

Troubleshooting chart

⚠ WARNING

Never check the fuel system while smoking or in the vicinity of an open flame.

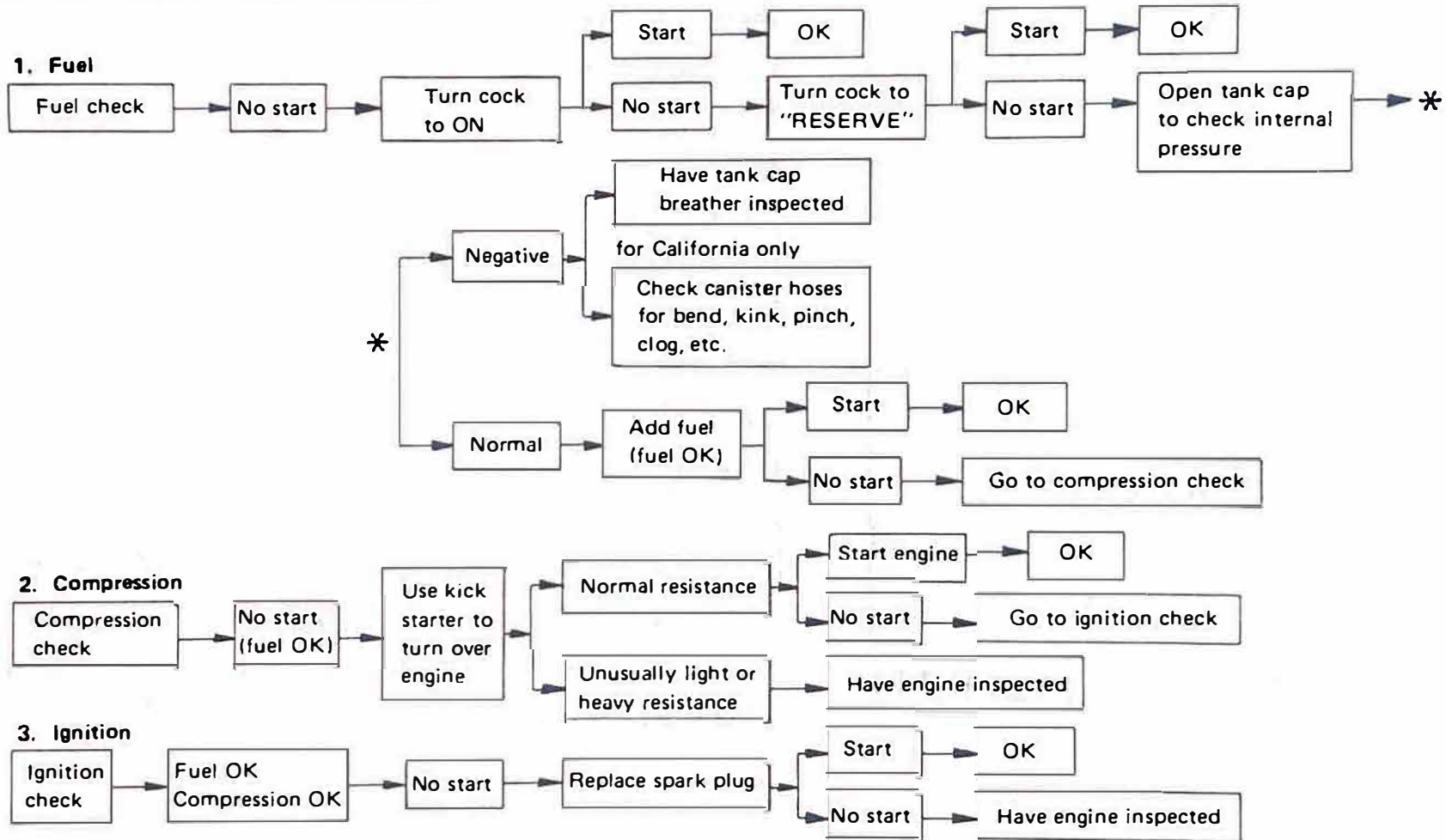

CLEANING AND STORAGE

EAK00201

A. CLEANING

Frequent, thorough cleaning of your machine will not only enhance its appearance but will improve its general performance and extend the useful life of many components.

1. Before cleaning the machine:
 - a. Block off the end of the exhaust pipe to prevent water entry; a plastic bag and strong rubber band may be used.
 - b. Make sure the spark plug(s) and all filler caps are properly installed.
2. If the engine case is excessively greasy, apply degreaser with a paint brush. Do not apply degreaser to the chain, sprockets, or wheel axles.
3. Rinse the dirt and degreaser off with a garden hose. Use only enough pressure to do the job.

EUU34601

CAUTION:

Excessive hose pressure may cause water seepage and deterioration of wheel bearings, front fork, brakes and transmission seals. Many expensive repair bills have resulted from improper high pressure detergent applications such as those available in coin-operated car washers.

4. Once the majority of the dirt has been hosed off, wash all surfaces with warm water and mild, detergent-type soap. An old toothbrush or bottle brush is handy for hard-to-get-at places.
5. Rinse the machine off immediately with clean water and dry all surfaces with a chamois, clean towel, or soft absorbent cloth.
6. Dry the chain and lubricate it to prevent rust.

7. Clean the seat with a vinyl upholstery cleaner to keep the cover pliable and glossy.
8. Automotive-type wax may be applied to all painted and chrome-plated surfaces. Avoid combination cleaner-waxes. Many contain abrasives which may mar the paint or protective finish. When finished, start the engine and let it idle for several minutes.

EAK01800

B. STORAGE

Long term storage (60 days or more) of your machine will require some preventive procedures to guard against deterioration. After thoroughly cleaning the machine, prepare for storage as follows:

1. Drain the fuel tank, fuel lines, and carburetor float bowl(s).
2. Remove the spark plug(s), pour about one tablespoon of SAE 10W30 or 20W40 motor oil in the spark plug hole(s) and reinstall the spark plug(s).

Kick the engine over several times (with the ignition off) to coat the cylinder walls with oil.

3. Remove the drive chain. Clean it thoroughly with solvent and lubricate it. Reinstall the chain or store it in a plastic bag (tied to frame for safe-keeping).
4. Lubricate all control cables.
5. Block up the frame to raise both wheels off the ground.
6. Tie a plastic bag over the exhaust pipe outlet to prevent moisture from entering.
7. If storing in a humid or salt-air atmosphere, coat all exposed metal surfaces with a light film of oil. Do not apply oil to any rubber parts or the seat cover.

EUU05800

NOTE: _____
Make any necessary repairs before storing the machine.

SPECIFICATIONS

| Model | www.legends-yamaha-enduros.com | RT100E |
|--|--|--|
| Dimension: Overall length Overall width Overall height Seat height Wheel base Minimum ground clearance | | 1,795 mm (70.7 in) 760 mm (29.9 in) 960 mm (37.8 in) 730 mm (28.7 in) 1,190 mm (46.9 in) 200 mm (7.9 in) |
| Basic weight: With oil and full fuel tank | | 79 kg (174 lb) |
| Minimum turning radius: | | 1,810 mm (71.3 in) |
| Engine: Type Model Cylinder arrangement Displacement Bore × Stroke Compression ratio Starting system Lubrication system | | Air-cooled 2-stroke, gasoline 3UL4 Single cylinder, Forward inclined 97 cm ³ 52.0 × 45.6 mm (2.05 × 1.80 in) 6.7 : 1 Kick starter Separate lubrication (Yamaha Autolube) |
| Engine oil (2-cycle) Type Capacity | | Yamalube 2, Air cooled 2-stroke engine oil 1.0 L (0.88 Imp qt, 1.06 US qt) |

| Model | www.legends-yamaha-enduros.com | RT100E |
|---|--|--------|
| Transmission oil: Type Capacity Periodic oil change Total amount | SAE 10W30 type SE motor oil 0.65 L (0.57 Imp qt, 0.69 US qt) 0.7 L (0.62 Imp qt, 0.74 US qt) | |
| Air filter: | Wet type element | |
| Fuel: Type Tank capacity Reserve amount | UNLEADED FUEL 5.0 L (1.1 Imp gal, 1.3 US gal) 1.5 L (0.3 Imp gal, 0.4 US gal) | |
| Carburetor: Type/manufacturer | VM22SS/MIKUNI | |
| Spark plug: Type/manufacturer Gap | B7ES/NGK 0.5 ~ 0.6 mm (0.020 ~ 0.024 in) | |
| Clutch type: | Wet, multi-disc | |

Model

www.legends-yamaha-enduros.com

RT100E

Transmission:

Primary reduction system
Primary reduction ratio
Secondary reduction system
Secondary reduction ratio
Transmission type
Operation
Gear ratio
 1st
 2nd
 3rd
 4th
 5th

Helical gear
74/19 (3.895)
Chain drive
48/14 (3.429)
Constant mesh 5-speed
Left foot operation

35/11 (3.182)
30/15 (2.000)
26/19 (1.368)
23/23 (1.000)
20/25 (0.800)

Chassis:

Frame type
Caster angle
Trail

Double cradle
29°
103 mm (4.1 in)

Tire:

Type
Size – Front
 Rear

With tube
2.50-18 4PR
3.00-16 4PR

Brake:

Front brake type
Operation
Rear brake type
Operation

Drum brake
Right hand operation
Drum brake
Right foot operation

| Model | RT100E |
|---|--|
| Suspension: Front Rear | Telescopic fork Swingarm |
| Shock absorber: Front Rear | Coil spring, Oil damper Coil spring, Oil damper |
| Wheel travel: Front Rear | 110 mm (4.3 in) 84 mm (3.3 in) |
| Electrical: Ignition system Generator system | CDI magneto Flywheel magneto |

MACHINE NOISE REGULATION

TAMPERING WITH NOISE CONTROL SYSTEM PROHIBITED:

Federal law prohibits the following acts or the causing thereof: (1) The removal or rendering inoperative by any person other than for purposes of maintenance, repair, or replacement of any device or element of design incorporated into any new vehicle for the purpose of noise control prior to its sale or delivery to the ultimate purchaser or while it is in use or (2) the use of the vehicle after such device or element of design has been removed or rendered inoperative by any person.

“AMONG THOSE ACTS PRESUMED TO CONSTITUTE TAMPERING ARE THE ACTS LISTED BELOW.”

These acts include tampering with the following systems; i.e., modification, removal, etc.

| | |
|----------------|--|
| Exhaust system | Muffler Exhaust pipe Silencer |
| Intake system | Air cleaner case Air cleaner element Intake duct |

MAINTENANCE RECORD

Make sure whoever performs the maintenance completes this record.

| MAINTENANCE INTERVAL | DATE OF SERVICE | MILEAGE | SERVICING DEALER NAME AND ADDRESS | REMARKS |
|---|-----------------|---------|-----------------------------------|---------|
| 1,000 km or 600 mi or 1 mo. | | | | |
| 6,000 km or 3,800 mi or 7 mos. | | | | |
| 11,000 km or 6,900 mi or 13 mos. | | | | |
| 16,000 km or 10,000 mi or 19 mos. | | | | |
| 21,000 km or 13,100 mi or 25 mos. | | | | |

www.legends-yamaha-enduros.com

| MAINTENANCE INTERVAL | DATE OF SERVICE | MILEAGE | SERVICING DEALER NAME AND ADDRESS | REMARKS |
|---|-----------------|---------|-----------------------------------|---------|
| 26,000 km or 16,200 mi or 31 mos. | | | | |
| 31,000 km or 19,300 mi or 37 mos. | | | | |
| 36,000 km or 22,400 mi or 43 mos. | | | | |
| 41,000 km or 25,500 mi or 49 mos. | | | | |
| 46,000 km or 28,600 mi or 55 mos. | | | | |
| 51,000 km or 31,700 mi or 61 mos. | | | | |

www.legends-yamaha-enduros.com

YAMAHA MOTOR CORPORATION, U.S.A.

OFF-ROAD MOTORCYCLE LIMITED WARRANTY

Yamaha Motor Corporation, U.S.A. hereby warrants that each new Yamaha off-road motorcycle purchased from an authorized Yamaha motorcycle dealer in the continental United States will be free from defects in material and workmanship for the period of time stated herein, subject to certain stated limitations.

THE PERIOD OF WARRANTY for Yamaha off-road motorcycles shall be ninety (90) days from the date of purchase, with no mileage limitation.

MODELS EXCLUDED FROM WARRANTY include those used for non-Yamaha-authorized renting, leasing, or other commercial purposes.

DURING THE PERIOD OF WARRANTY any authorized Yamaha motorcycle dealer will, free of charge, repair or replace, at Yamaha's option, any part adjudged defective by Yamaha due to faulty workmanship or material from the factory. Parts used in warranty repairs will be warranted for the balance of the product's warranty period. All parts replaced under warranty become property of Yamaha Motor Corp. U.S.A.

GENERAL EXCLUSIONS from this warranty shall include any failures caused by:

- a. Competition or racing use (except TY models used for sanctioned trials).
- b. Installation of parts or accessories that are not qualitatively equivalent to genuine Yamaha parts.
- c. Abnormal strain, neglect, or abuse.
- d. Lack of proper maintenance.
- e. Accident or collision damage.
- f. Modification to original parts.

SPECIFIC EXCLUSIONS from this warranty shall include parts replaced due to normal wear or routine maintenance.

THE CUSTOMER'S RESPONSIBILITY under this warranty shall be to:

1. Operate and maintain the motorcycle as specified in the appropriate Owner's Manual, and
2. Give notice to an authorized Yamaha motorcycle dealer of any and all apparent defects within ten (10) days after discovery, and make the machine available at that time for inspection and repairs at such dealer's place of business.

WARRANTY TRANSFER: To transfer the warranty from the original purchaser to any subsequent purchaser, it is imperative that the machine be inspected and registered for warranty by an authorized Yamaha motorcycle dealer. In order for this warranty to remain in effect, this inspection and registration must take place within ten (10) days after transfer. An inspection and registration fee will be charged for this service.

YAMAHA MOTOR CORPORATION, U.S.A. MAKES NO OTHER WARRANTY OF ANY KIND, EXPRESSED OR IMPLIED. ALL IMPLIED WARRANTIES OF MERCHANTABILITY AND FITNESS FOR A PARTICULAR PURPOSE WHICH EXCEED THE OBLIGATIONS AND TIME LIMITS STATED IN THIS WARRANTY ARE HEREBY DISCLAIMED BY YAMAHA MOTOR CORPORATION, U.S.A. AND EXCLUDED FROM THIS WARRANTY.

SOME STATES DO NOT ALLOW LIMITATIONS ON HOW LONG AN IMPLIED WARRANTY LASTS, SO THE ABOVE LIMITATION MAY NOT APPLY TO YOU. ALSO EXCLUDED FROM THIS WARRANTY ARE ANY IN-

CIDENTAL OR CONSEQUENTIAL DAMAGES INCLUDING LOSS OF USE. SOME STATES DO NOT ALLOW THE EXCLUSION OR LIMITATION OF INCIDENTAL OR CONSEQUENTIAL DAMAGES, SO THE ABOVE EXCLUSION MAY NOT APPLY TO YOU.

THIS WARRANTY GIVES YOU SPECIFIC LEGAL RIGHTS, AND YOU MAY ALSO HAVE OTHER RIGHTS WHICH VARY FROM STATE TO STATE.

YAMAHA MOTOR CORPORATION, U.S.A.
P. O. Box 6555
Cypress, California 90630

WARRANTY QUESTIONS AND ANSWERS

- Q. What costs are my responsibility during the warranty period?
- A. The customer's responsibility includes all costs of normal maintenance services, non-warranty repairs, accident and collision damages, and oil, oil filters, air filters, spark plugs, and brake shoes.
- Q. What are some examples of "abnormal" strain, neglect, or abuse?
- A. Those terms are general and overlap each other in areas. Specific examples include: Running the machine out of oil, sustained high-rpm, full-throttle use; operating the machine with a broken or damaged part which causes another part to fail, damage or failure due to improper or careless transportation and or tie down; and so on. If you have any specific questions on operation or maintenance, please contact your dealer for advice.
- Q. Does the warranty cover incidental costs such as towing or transportation due to a failure?
- A. No. The warranty is limited to repair of the machine itself.
- Q. May I perform any or all of the recommended maintenance shown in the Owner's Manual instead of having the dealer do them?
- A. Yes, if you are a qualified mechanic and follow the procedures specified in the Owner's and Service Manual. We do recommend, however, that items requiring special tools or equipment be done by a Yamaha motorcycle dealer.
- Q. Will the warranty be void or cancelled if I do not operate or maintain my new motorcycle exactly as specified in the Owner's Manual?
- A. No. The warranty on a new motorcycle cannot be "voided" or "cancelled." **However, if a particular failure is caused by operation or maintenance other than as shown in the Owner's Manual, that failure may not be covered under warranty.**
- Q. What responsibility does my dealer have under this warranty?
- A. Each Yamaha motorcycle dealer is expected to:
1. Completely set up every new machine before sale.
 2. Explain the operation, maintenance, and warranty requirements to your satisfaction at the time of sale, and upon your request at any later date.
- Q. Is the warranty transferable to second owners?
- A. Yes. The remainder of the existing warranty can be transferred upon request. The unit has to be inspected and re-registered by an authorized Yamaha motorcycle dealer for the policy to remain effective.

CUSTOMER SERVICE

If your machine requires warranty service, you must take it to any authorized Yamaha motorcycle dealer within the continental United States. Be sure to bring your warranty registration identification or other valid proof of the original date of purchase. If a question or problem arises regarding warranty, first contact the owner of the dealership. Since all warranty matters are handled at the dealer level, this person is in the best position to help you. If you are still not satisfied and require additional assistance, please write:

YAMAHA MOTOR CORPORATION U.S.A.
CUSTOMER RELATIONS DEPARTMENT
P.O. Box 6555
Cypress, California 90630

When contacting Yamaha Motor Corporation, U.S.A. don't forget to include any important information such as names, addresses, model, engine serial number, dates, and receipts.

CHANGE OF ADDRESS

The federal government requires each manufacturer of a motor vehicle to maintain a complete, up-to-date list of all first purchasers against the possibility of a safety-related defect and recall. This list is compiled from the purchase registrations sent to Yamaha Motor Corporation, U.S.A. by the selling dealer at the time of your purchase.

If you should move after you have purchased your new motorcycle, please advise us of your new address by sending a postcard listing your motorcycle model name, engine serial number, dealer number (or dealer's name) as it is shown on your warranty identification, your name and new mailing address. Mail to:

YAMAHA MOTOR CORPORATION, U.S.A.
P.O. Box 6555
Cypress, California 90630

This will ensure that Yamaha Motor Corporation, U.S.A. has an up-to-date registration record in accordance with federal law.

WIRING DIAGRAM

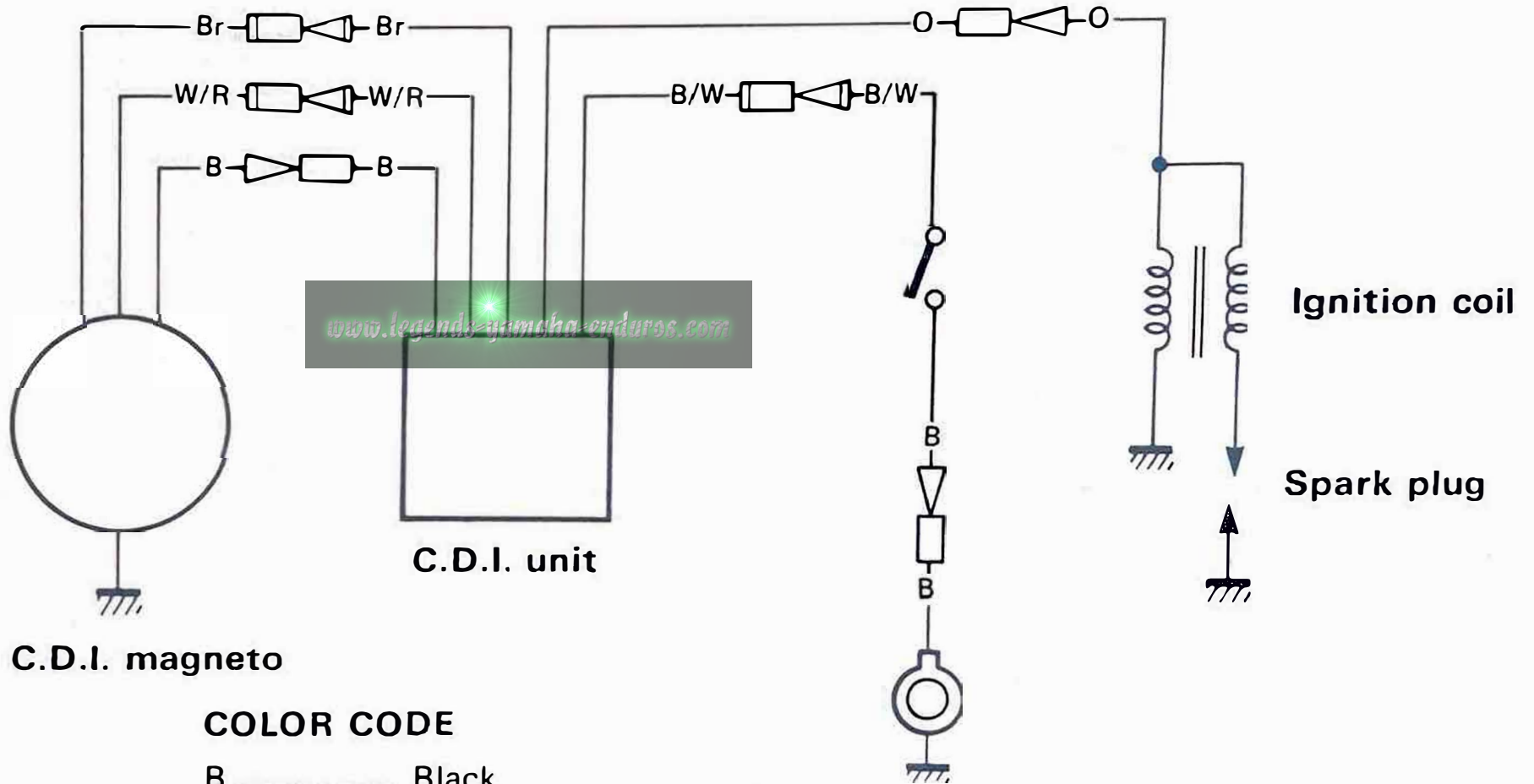

www.legends-yamaha-enduros.com

COLOR CODE

- B Black
- O Orange
- Br Brown
- B/W Black/White
- W/R White/Red

PROTECT YOUR INVESTMENT

Use Genuine YAMAHA Parts And Accessories

See your Authorized YAMAHA Dealer for a Genuine YAMAHA Service Manual.

www.legends-yamaha-enduros.com

YAMAHA MOTOR CO.,LTD.

PRINTED IN JAPAN
92 · 6 - 0.8 x 1 CR
(英)