



YAMAHA

PARTS CATALOGUE

AG175H (4M3)

www.legends-yamaha-enduros.com

114M3-700E2

FOREWORD



FOREWORD

This Parts Catalogue is related to the parts in use for the Yamaha AG 175H (4M3).
When you are ordering replacement parts for the AG 175H (4M3), refer to this Parts Catalogue and quote both part numbers and part names correctly.

1. Modifications or additions which have been made after issue of the Parts Catalogue will be announced in the Yamaha Parts News.
It is advisable that according to the Yamaha Parts News you make necessary corrections to the Parts Catalogue on hand to keep it up-to-date.

2. Abbreviations

The following abbreviations are used in this Parts Catalogue.

- U.R. Use size (thickness) and/or number as required.
- U.N. Use as many as you need.
- A.P. Alternate Parts
- L.M. Local Made
- F# Frame No. (Applicable machine No.)

3. The parts marked with (+) in the parts number column of this Catalogue are not supplied with by Yamaha, those have to be found locally.

4. Parts, which are to be supplied in the form of assemblies, are listed with an indention of one letter's space, and a dot (.) is put against the name of each part.

EXAMPLE CARBURETOR ASS'Y
 . JET, pilot
 . NOZZLE, main

5. Indication of No. of constituent parts for assembly

The numeral appearing to the right of each constituent part under the description indicates the quantity of such parts for each individual assembly unit.

EXAMPLE

Part No.	Description	Q'ty	Remarks
2F5-83310-60	FRONT FLASHER LIGHT ASS'Y	2	
115-83311-60	. BULB (6V-18W)	1	
1M1-83309-60	. REFLECTOR	1	

6. Initial Serial No. and Color Code

(A) Frame Serial No.	4M3-000101 and following
(B) Engine Serial No.	4M3-000101 and following

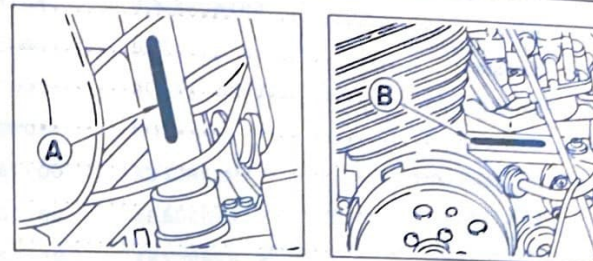

Color Code	Color Name	Abbreviate
26	Competition Yellow	CPY

7. Applicable colors of graphics are represented in the "Remarks" column by the letter(s) appropriately picked out of the full word(s) showing such colors.

EXAMPLE

Part No.	Description	Q'ty	Remarks
2N4-24110-00 X5	FUEL TANK COMP.	1	MAXIM RED
3J1-24240-10	. GRAPHIC, fuel tank set	1	for MXR

CONTENTS

ENGINE

Fig. 1	Cylinder Head - Cylinder	1
Fig. 2	Crankshaft - Piston	2
Fig. 3	C.D.I Magneto	3
Fig. 4	Oil Pump	4
Fig. 5	Intake	5
Fig. 6	Carburetor	6
Fig. 7	Exhaust	8
Fig. 8	Crankcase	9
Fig. 9	Crankcase Cover	10
Fig. 10	Kick Starter	11
Fig. 11	Clutch	12
Fig. 12	Transmission	14
Fig. 13	Shift Cam - Fork	16
Fig. 14	Shift Shaft - Pedal	17

CHASSIS

Fig. 15	Frame	18
Fig. 16	Front Fender - Rear Fender	19
Fig. 17	Side Cover	20
Fig. 18	Oil Tank	21
Fig. 19	Rear Arm	22
Fig. 20	Rear Suspension	24
Fig. 21	Steering	25
Fig. 22	Front Fork	26
Fig. 23	Fuel Tank	28
Fig. 24	Seat	29
Fig. 25	Front Wheel	30
Fig. 26	Rear Wheel	32
Fig. 27	Handlebar - Cable	34
Fig. 28	Stand - Footrest	35
Fig. 29	Flasher Light	36
Fig. 30	Meter	37

Fig. 31	Headlight	38
Fig. 32	Taillight	39
Fig. 33	Electrical 1	40
Fig. 34	Handle Switch - Lever	42

REPAIR KIT

Fig. 35	Repair Kit	43
---------	------------	----

INDEX

Numerical Index
Parts Name Index

FIG. 1 CYLINDER HEAD. CYLINDER

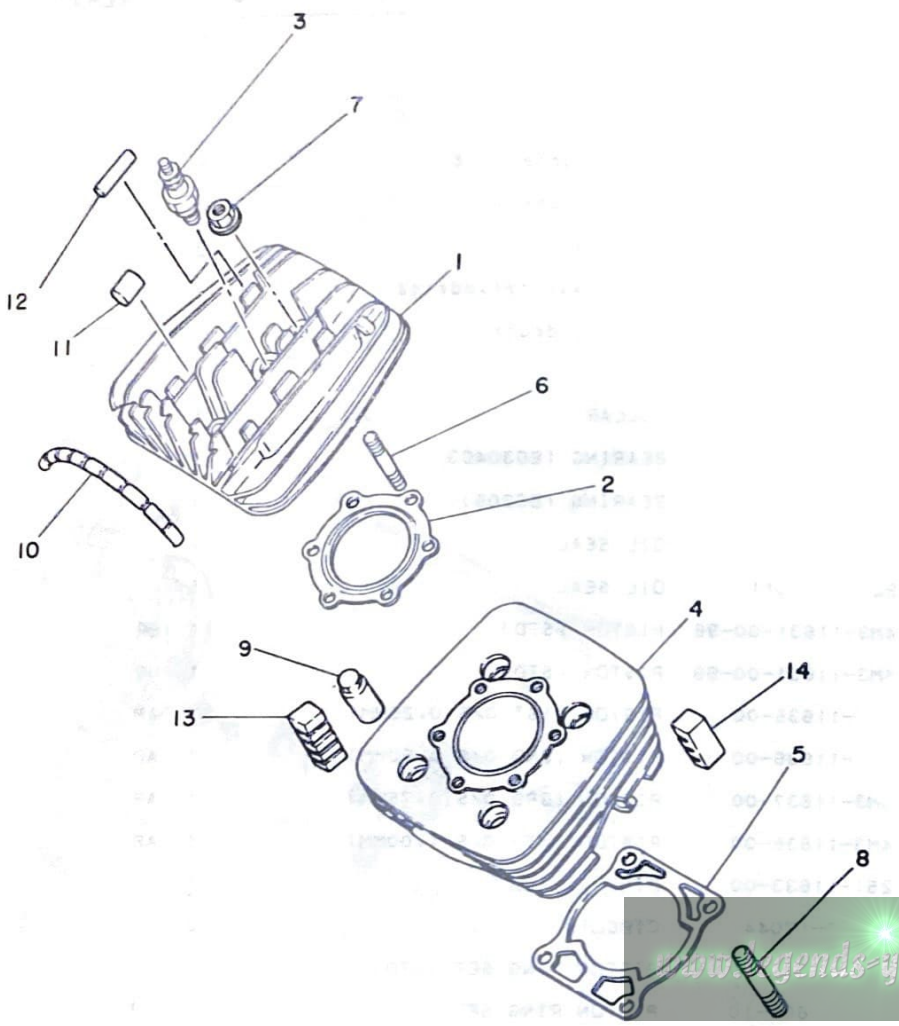

REF. NO.	PART NO.	DESCRIPTION	Q'TY	REMARKS
1	4M3-11111-00	HEAD, cylinder 1	1	
2	1W2-11181-10	GASKET, cylinder head 1	1	
3	94701-00043	PLUG, sPark	1	
4	4M3-11311-00	CYLINDER 1	1	
5	3M5-11351-01	GASKET, cylinder	1	
6	90116-08104	BOLT, stud	6	
7	90179-08065	NUT	6	
8	95611-10630	BOLT, stud	4	
9	90179-10201	NUT	4	
10	2A6-11161-00	ABSORBER 1	1	
11	2A6-11162-00	ABSORBER 2	1	
12	579-11162-00	ABSORBER 2	2	
13	2A6-11127-00	ABSORBER 3	2	
14	2A6-11128-00	ABSORBER 4	2	



4M3700-0010

B2

FIG. 2 CRANKSHAFT-PISTON

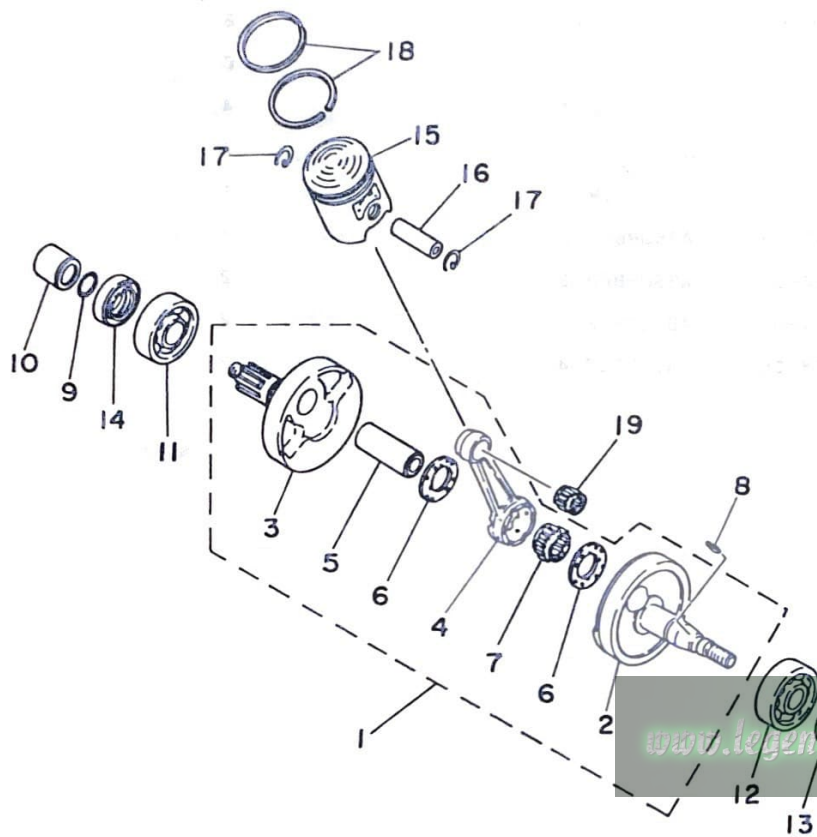

REF. NO.	PART NO.	DESCRIPTION	Q'TY	REMARKS
1	482-11400-00	CRANKSHAFT ASSY	1	
2	482-11412-00	.CRANK 1	1	
3	248-11422-00	.CRANK 2	1	
4	2N4-11651-00	.ROD, connecting	1	
5	3M5-11681-00	.PIN, crank 1	1	
6	90209-22071	.WASHER	2	
7	93310-42231	.BEARING, cylindrical	1	
8	90280-05013	KEY, woodruff	1	
9	93210-18023	O-RING	1	
10	90387-20170	COLLAR	1	
11	93306-30405	BEARING (B6304C3)	1	
12	93306-20517	BEARING (B6205)	1	
13	93102-25061	OIL SEAL	1	
14	93103-28011	OIL SEAL	1	
15	4M3-11631-00-96	PISTON (STD)	1	UR
	4M3-11631-00-98	PISTON (STD)	1	UR
	4M3-11635-00	PISTON (1ST O/S 0.25MM)	1	AP
	4M3-11636-00	PISTON (2ND O/S 0.50MM)	1	AP
	4M3-11637-00	PISTON (3RD O/S 0.75MM)	1	AP
	4M3-11638-00	PISTON (4TH O/S 1.00MM)	1	AP
16	251-11633-00	PIN, Piston	1	
17	93450-17044	CIRCLIP	2	
18	4M3-11601-00	PISTON RING SET (STD)	1	
	4M3-11601-10	PISTON RING SET (1ST O/S)	1	AP
	4M3-11601-20	PISTON RING SET (2ND O/S)	1	AP
	4M3-11601-30	PISTON RING SET (3RD O/S)	1	AP
	4M3-11601-40	PISTON RING SET (4TH O/S)	1	AP
19	93310-216E1	BEARING, cylindrical	1	



4M3700-0020

B3

FIG. 3 C.D.I MAGNETO

REF. NO.	PART NO.	DESCRIPTION	Q'TY	REMARKS
1	4M3-85500-10	C.D.I. MAGNETO ASSY	1	
2	4M3-81309-10	•BASE, magneto	1	
3	4M3-85550-10	•ROTOR ASSY	1	
4	482-85520-10	•COIL, charge	1	
5	8G9-85541-10	•COIL, charge	1	
6	647-81318-10	•SPACER	2	
7	482-81347-10	•SCREW, Pan head	2	
8	4M3-85533-10	•COIL, lighting	1	
9	482-81324-10	•SCREW 2	2	
10	482-81328-10	•CLAMP	1	
11	482-81323-10	•SCREW 1	1	
12	4M3-8131X-10	•CORD ASSY	1	
13	109-81328-11	•CLAMP	1	
14	482-81323-10	•SCREW 1	1	
15	90480-16110	•GROMMET	1	
16	92701-06015	SCREW, flat head	2	
17	90462-05012	CLAMP	1	
18	90201-12535	WASHER, Plate	1	
19	92901-12100	WASHER, sPring	1	
20	90170-12067	NUT	1	
21	353-81970-50	RECTIFIER ASSY	1	UR
	353-81970-63	RECTIFIER ASSY	1	UR
22	96501-05020	SCREW, Pan head	1	
23	92901-05600	WASHER, Plate	1	

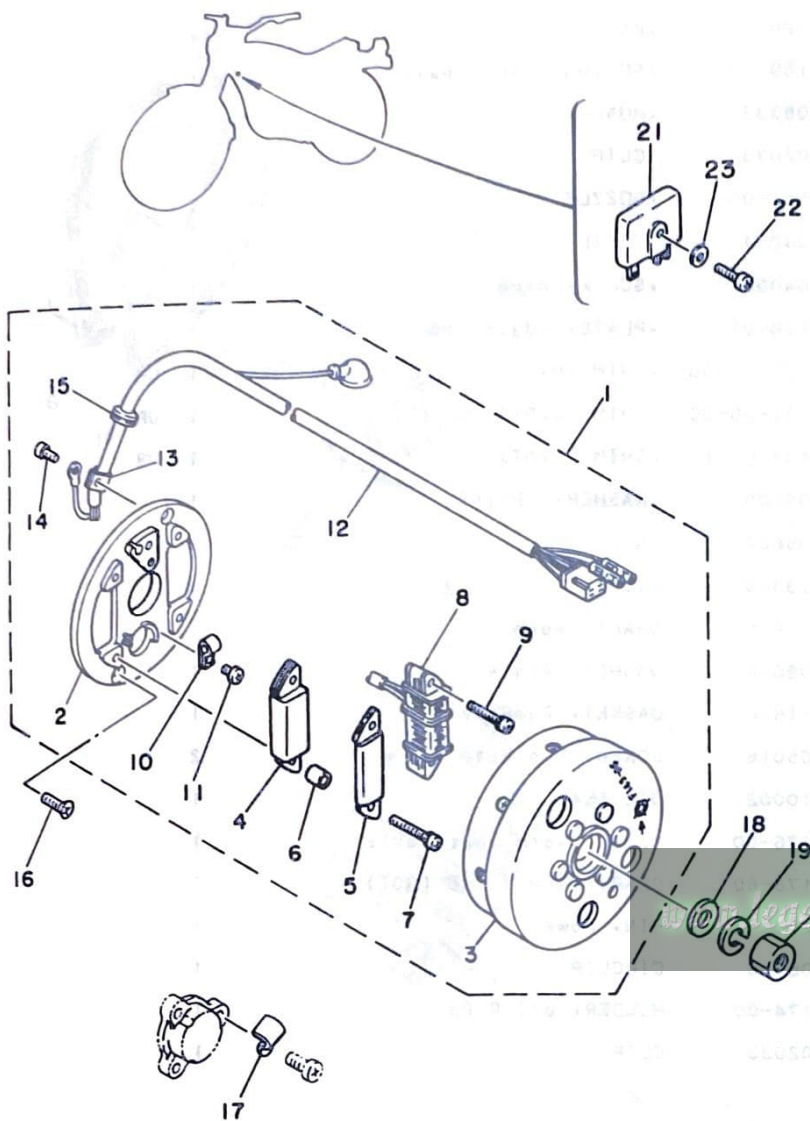

4M3700-0030

B4

FIG. 4 OIL PUMP

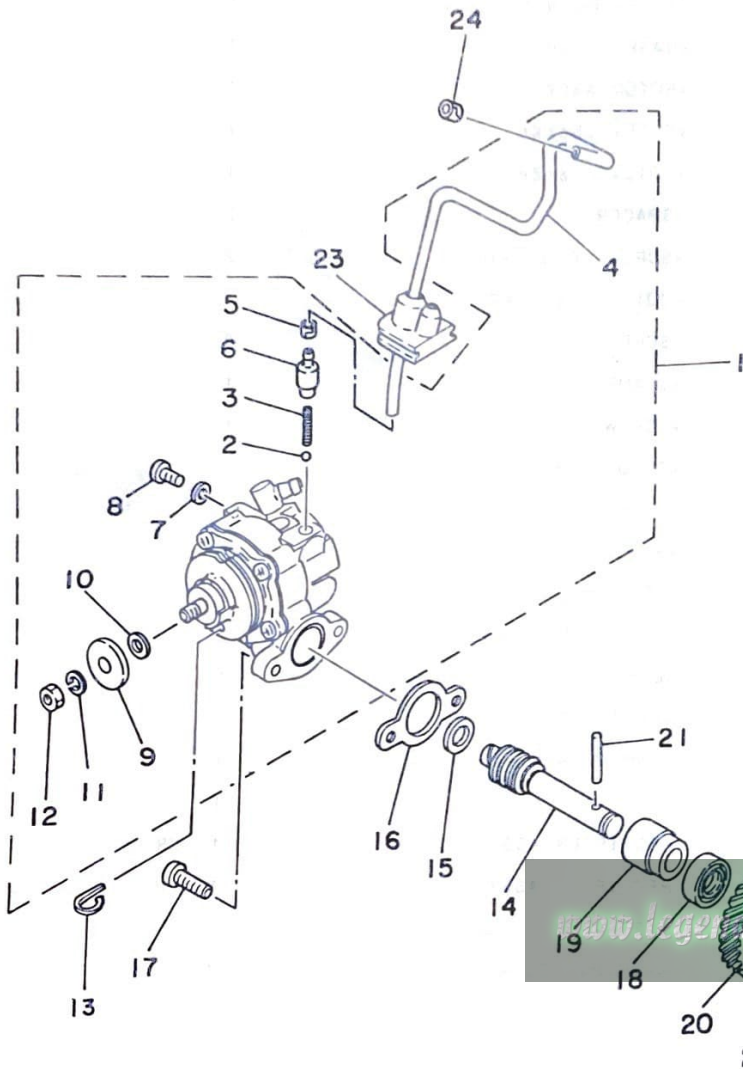

REF. NO.	PART NO.	DESCRIPTION	Q'TY	REMARKS
1	4M3-13101-00	OIL PUMP ASSY	1	
2	93505-32002	.BALL	1	
3	278-13169-00	.SPRING, check ball	1	
4	90445-05333	.HOSE	1	
5	90468-02033	.CLIP	1	
6	402-13552-00	.NOZZLE	1	
7	90430-04004	.GASKET	1	
8	98901-04008	.SCREW, bind	1	
9	137-13138-01	.PLATE, adjustinG	1	
10	137-13137-00-03	.SHIM (0.3T)	1	UR
	137-13137-00-05	.SHIM (0.5T)	1	UR
	137-13137-00-10	.SHIM (1.0T)	1	UR
11	92901-05100	.WASHER, sPrinG	1	
12	95301-05600	.NUT	1	
13	363-13133-01	CLIP	1	
14	275-13175-01	SHAFT, worm	1	
15	90201-08624	WASHER, Plate	1	
16	126-13116-00	GASKET, Pump case	1	
17	98501-05016	SCREW, Pan head	2	
18	93101-10002	OIL SEAL	1	
19	137-13176-00	METAL, worm shaft outer	1	
20	382-13178-60	GEAR, Pump drive (30T)	1	
21	93603-22028	PIN, dowel	1	
22	93430-08006	CIRCLIP	1	
23	525-13174-00	HOLDER, oil Pipe	1	
24	90468-02033	CLIP	1	



4M3700-0040

B5

FIG. 5 INTAKE

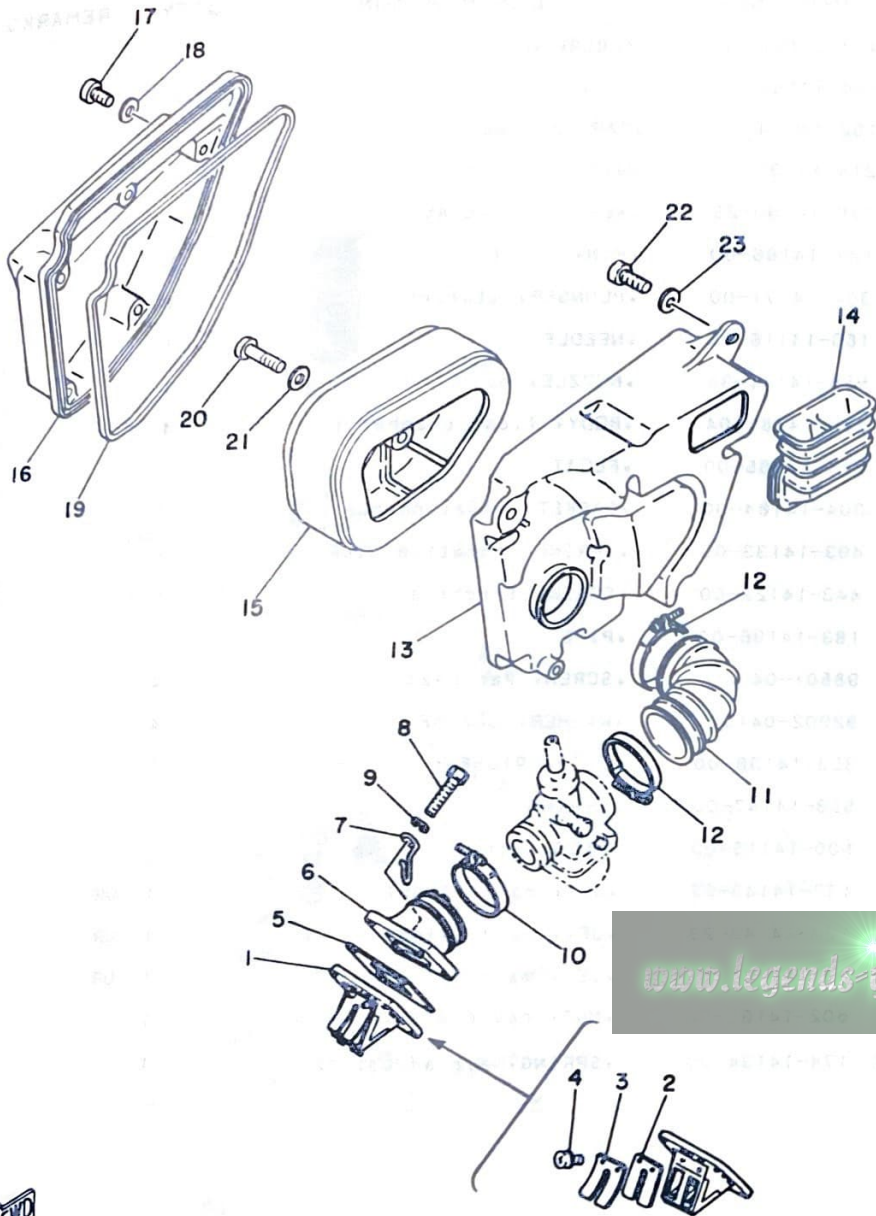

REF. NO.	PART NO.	DESCRIPTION	Q'TY	REMARKS
1	345-13610-10	REED VALVE ASSY	1	
2	1A0-13613-00	•REED, valve	2	
3	345-13616-70	•STOPPER, reed valve	2	
4	97602-03108	•SCREW, Pan head with washer	4	
5	314-13621-02	GASKET, valve seat	1	
6	525-13565-01	JOINT, carburetor	1	
7	90462-20029	CLAMP	1	
8	97301-06025	BOLT	4	
9	92901-06600	WASHER, Plate	4	
10	90460-43053	CLAMP, hose	1	
11	4M3-14453-00	JOINT, air cleaner 1	1	
12	90460-51059	CLAMP, hose	2	
13	3V6-14411-00	CASE, air cleaner 1	1	
14	1Y8-14437-01	DUCT	1	
15	3V6-14451-00	ELEMENT, air cleaner	1	
16	3V6-14412-00	CAP, cleaner case 1	1	
17	92501-06015	SCREW, Pan head	5	
18	92901-06600	WASHER, Plate	5	
19	3V6-14416-00	GASKET, air cleaner	1	
20	92501-06035	SCREW, Pan head	1	
21	90201-06067	WASHER, Plate	1	
22	92501-06020	SCREW, Pan head	2	
23	90201-06067	WASHER, Plate	2	

www.legends-ya.com



FIG. 6 CARBURETOR

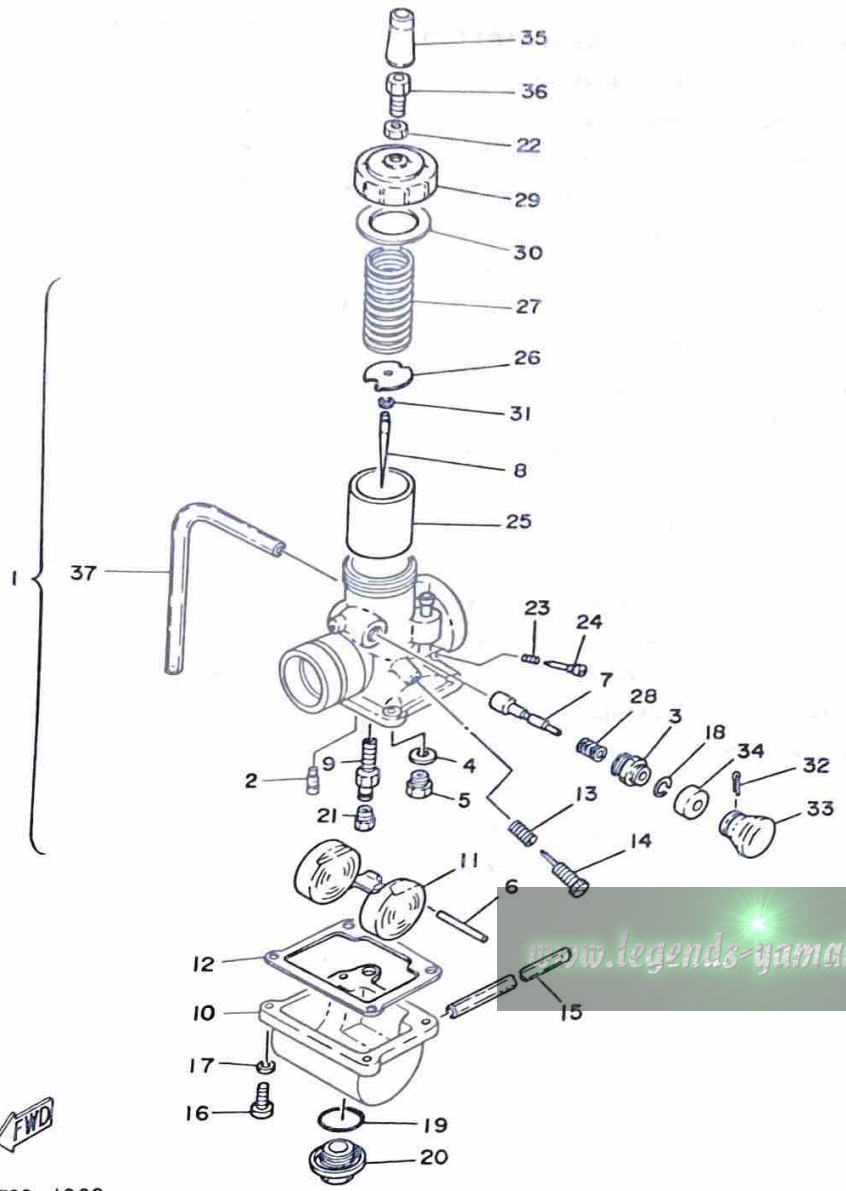

REF. NO.	PART NO.	DESCRIPTION	Q'TY	REMARKS
1	4M3-14101-00	CARBURETOR ASSY 1	1	
2	260-14142-27	.JET, Pilot (#27.5)	1	
3	152-14174-00	.CAP, Plunger	1	
4	214-14195-00	.WASHER, needle valve	1	
5	1V0-14190-25	.NEEDLE VALVE ASSY	1	
6	127-14186-00	.PIN, float	1	
7	304-14171-00	.PLUNGER, starter	1	
8	166-14116-13	.NEEDLE	1	
9	558-14141-34	.NOZZLE, main	1	
10	539-14181-04	.BODY, float chamber 1	1	
11	314-14185-00	.FLOAT	1	
12	304-14184-00	.GASKET, float chamber	1	
13	493-14133-00	.SPRING, throttle stop	1	
14	443-14122-00	.SCREW, throttle	1	
15	183-14196-00	.PIPE	2	
16	98501-04016	.SCREW, Pan head	4	
17	92902-04100	.WASHER, spring	4	
18	353-14138-00	.CLIP, Plunger	1	
19	558-14147-00	.O-RING	1	
20	500-14115-00	.PLUG, screw	1	
21	137-14143-27	.JET, main (#135)	1	UR
	137-14143-29	.JET, main (#145)	1	UR
	137-14143-31	.JET, main (#155)	1	UR
22	802-14161-00	.NUT, cable adjusting	1	
23	174-14134-00	.SPRING, air adjusting	1	



4M3700-1060

B7

FIG. 6 CARBURETOR

REF. NO.	PART NO.	DESCRIPTION	Q'TY	REMARKS
24	174-14123-00	•SCREW, air adjusting	1	
25	314-14112-20	•VALVE, throttle 1	1	
26	246-14132-00	•STOPPER, cable	1	
27	248-14131-00	•SPRING, throttle valve	1	
28	156-14135-00	•SPRING, Plunger	1	
29	802-14158-00	•TOP, mixing chamber	1	
30	246-14126-00	•GASKET	1	
31	164-14137-00	•CLIP	1	
32	91402-16015	•PIN, cotter	1	
33	304-14261-00	•HOLDER	1	
34	132-14173-00	•COVER, Plunger cap	1	
35	307-14169-10	•CAP	1	
36	127-14124-20	•SCREW, cable adjusting	1	
37	183-14197-01	•PIPE	1	

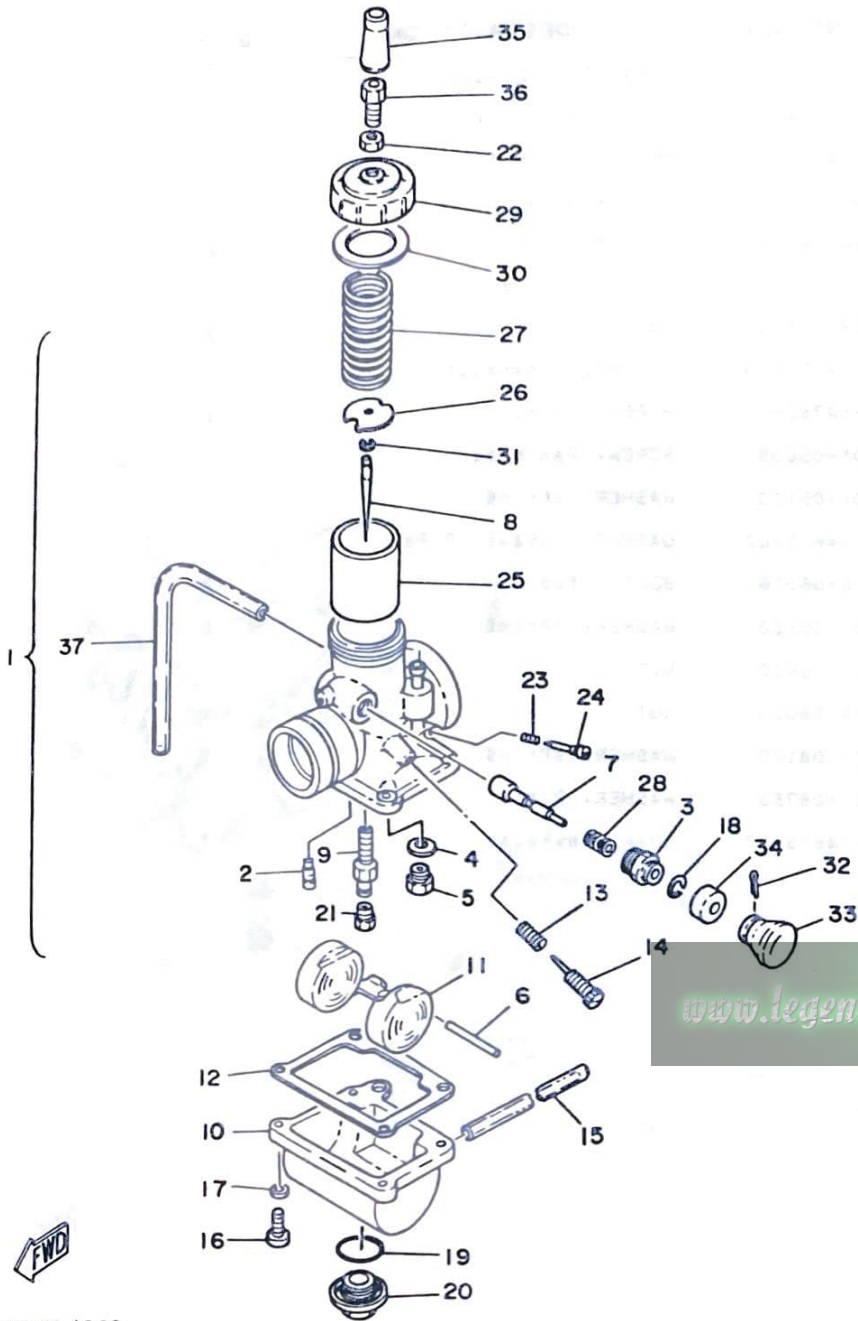

4M3700-1060

B8

FIG. 7 EXHAUST

REMARKS

DESCRIPTION

PART NO.

REF. NO.	PART NO.	DESCRIPTION	Q'TY	REMARKS
1	4M3-14610-00	EXHAUST PIPE ASSY 1	1	
2	3V6-14718-00	PROTECTOR, muffler 1	1	
3	3V6-14728-00	PROTECTOR, muffler 2	1	
4	98906-06012	SCREW, bind	4	
5	90202-06010	WASHER, Plate	4	
6	90202-05005	WASHER, Plate	4	
7	90209-06194	WASHER	2	
8	4M3-14753-00	SILENCER, exhaust	1	
9	4M3-14752-00	PIPE, outlet	1	
10	98501-05008	SCREW, Pan head	1	
11	92901-05100	WASHER, sPring	1	
12	152-14613-00	GASKET, exhaust Pipe	1	
13	90116-06016	BOLT, stud	2	
14	92901-06100	WASHER, sPring	2	
15	95301-06600	NUT	2	
16	95301-08600	NUT	1	
17	92901-08100	WASHER, sPring	1	
18	90201-08753	WASHER, Plate	1	
19	3M7-14615-00	JOINT, exhaust 1	1	

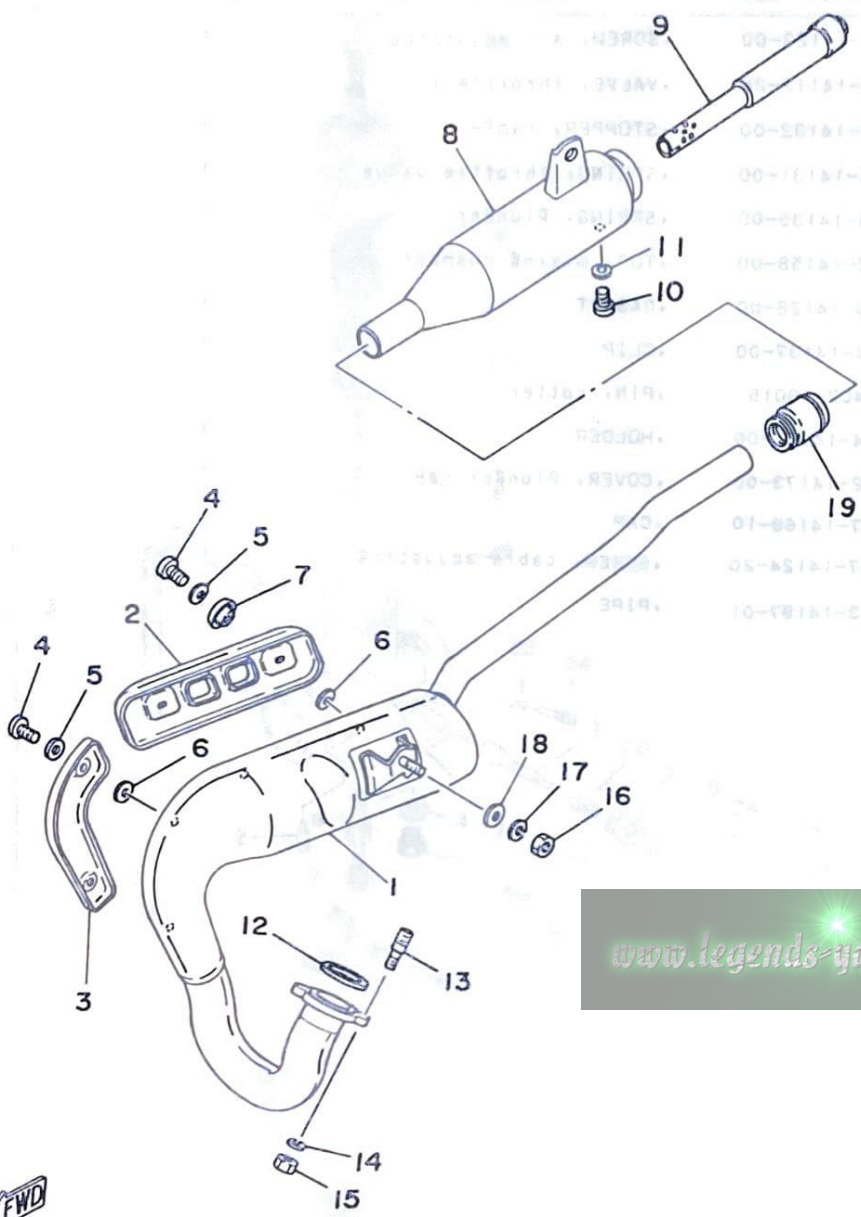

www.legends-yamaha-enduros.com



4M3700-0070

FIG. 8 CRANKCASE

REF. NO.	PART NO.	DESCRIPTION	Q'TY	REMARKS
1	4M3-15111-01	CRANKCASE 1	1	
2	92501-06045	SCREW, Pan head	6	
3	92501-06055	SCREW, Pan head	2	
4	92501-06065	SCREW, Pan head	4	
5	91830-21014	PIN, dowel	1	
6	91830-24016	PIN, dowel	1	
7	3M5-15121-00	CRANKCASE 2	1	
8	304-15128-00	HOLDER	1	
9	92501-08010	SCREW, Pan head	1	
10	498-15371-00	BREATHER	1	
11	90446-07009	HOSE	1	
12	90340-12005	PLUG, straight screw	1	
13	90430-12038	GASKET	1	

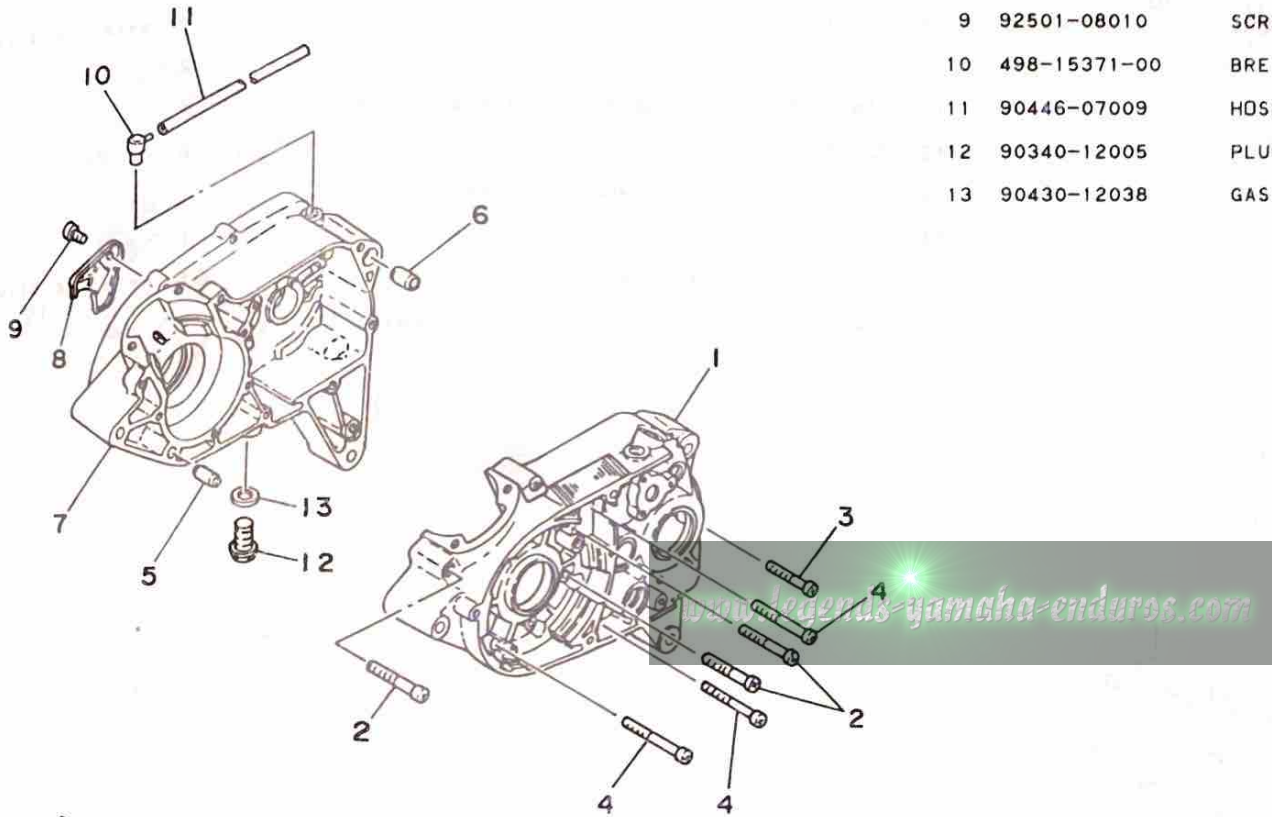
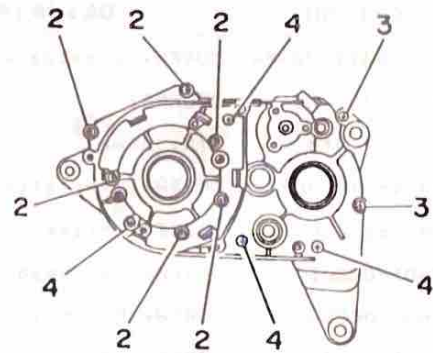

4M3700-0080

B10

FIG. 9 CRANKCASE COVER

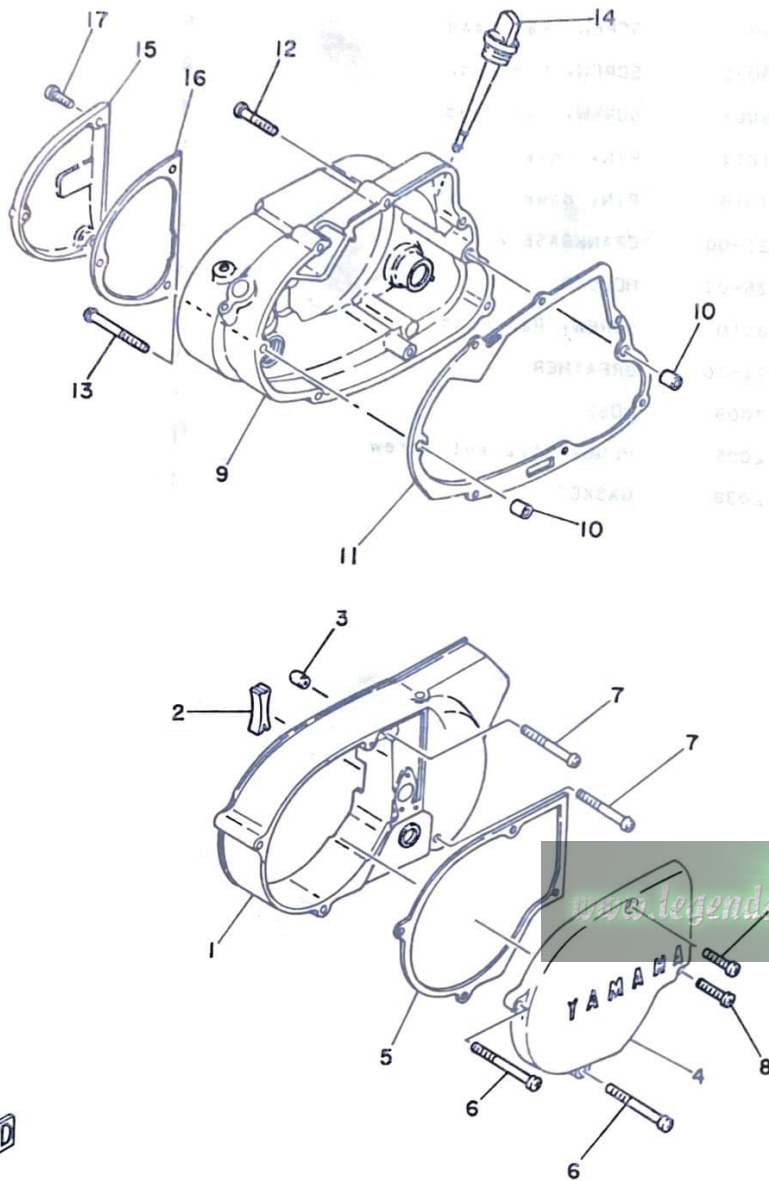

REF. NO.	PART NO.	DESCRIPTION	Q'TY	REMARKS
1	482-15411-00-Y4	COVER, crankcase 1	1	metallic silver
2	248-15357-00	GROMMET	1	
3	91830-21014	PIN, dowel	2	
4	314-15415-00-Y4	COVER, Generator	1	metallic silver
5	314-15455-00	GASKET, crankcase cover	1	
6	92501-06065	SCREW, Pan head	2	
7	92501-06055	SCREW, Pan head	2	
8	92501-06030	SCREW, Pan head	2	
9	314-15421-00-Y4	COVER, crankcase 2	1	metallic silver
10	91810-02014	PIN, dowel	2	
11	315-15451-02	GASKET, crankcase cover	1	
12	92501-06035	SCREW, Pan head	6	
13	92501-06060	SCREW, Pan head	1	
14	315-15362-01	PLUG, oil level	1	
15	314-15416-00-Y4	COVER, oil Pump	1	metallic silver
16	444-15456-00	GASKET, oil Pump cover 1	1	
17	92501-06020	SCREW, Pan head	3	



4M3700-0090

B11

FIG. 10 KICK STARTER

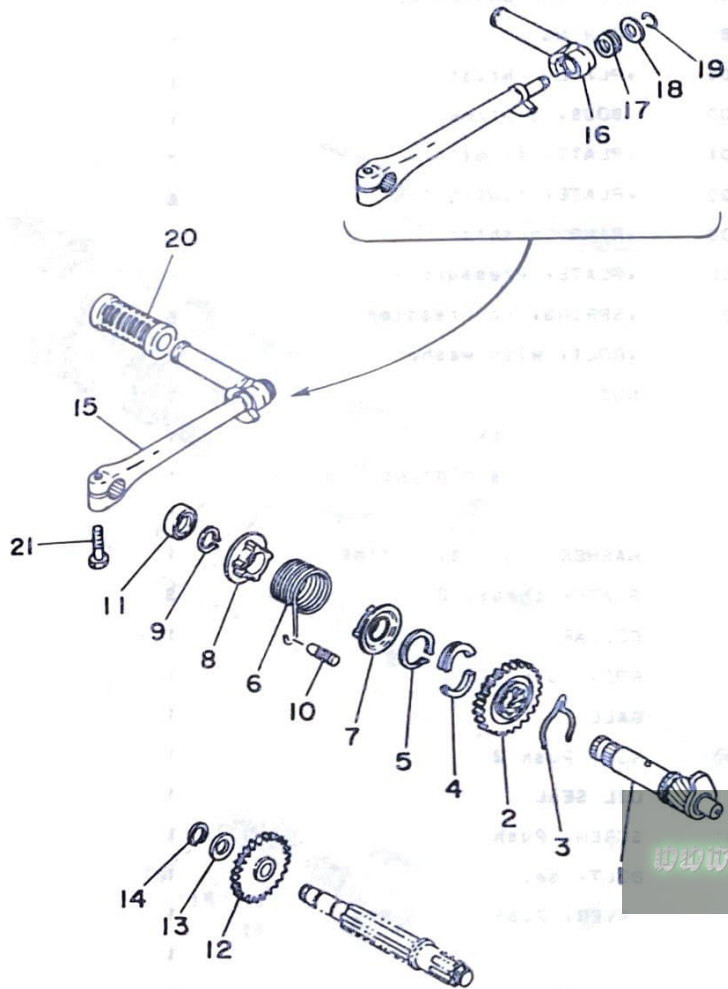

REF. NO.	PART NO.	DESCRIPTION	Q'TY	REMARKS
1	315-15660-00	KICK AXLE ASSY	1	
2	315-15641-00	GEAR, kick (27T)	1	
3	90468-26048	CLIP	1	
4	248-15654-00	HOLDER, kick gear	2	
5	93410-30012	CIRCLIP	1	
6	90508-26040	SPRING, torsion	1	
7	214-15664-00	GUIDE, spring	1	
8	214-15676-00	COVER, spring	1	
9	93410-20009	CIRCLIP	1	
10	248-15668-00	STOPPER	1	
11	93104-20017	OIL SEAL	1	
12	1E8-15651-00	GEAR, kick idle (26T)	1	
13	132-15653-00-10	WASHER	1	
14	93410-13004	CIRCLIP	1	
15	3V6-15610-00	KICK CRANK ASSY	1	
16	214-15612-01	•LEVER, kick	1	
17	90504-18009	•SPRING, compression	1	
18	214-15616-00	•WASHER, kick lever	1	
19	93440-11029	•CIRCLIP	1	
20	214-15618-00	COVER, kick lever	1	
21	97321-08030	BOLT	1	

www.legends-yamaha-enduros.com



4M3700-0100



FIG. 11 CLUTCH

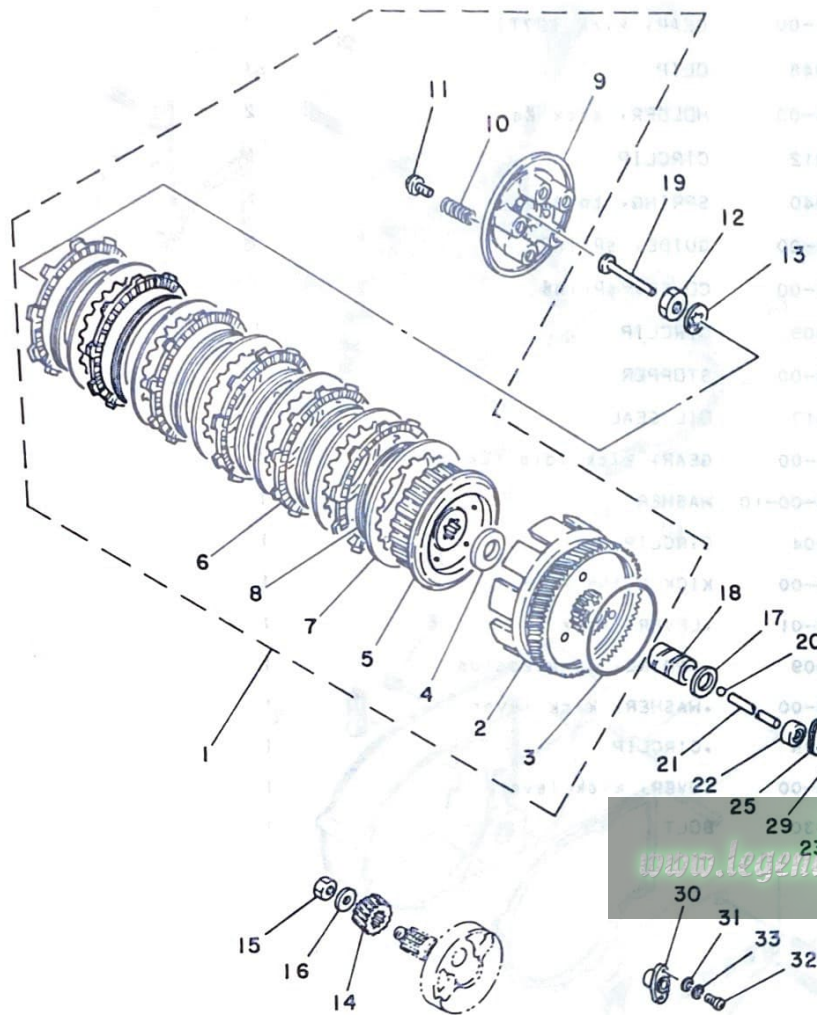

REF. NO.	PART NO.	DESCRIPTION	Q'TY	REMARKS
1	4M3-16300-00	CLUTCH ASSY	1	
2	4M3-16150-00	.PRIMARY DRIVEN GEAR COMP.	1	
3	93210-89268	.O-RING	1	
4	174-16154-00	.PLATE, thrust 1	1	
5	1E8-16371-00	.BOSS, clutch	1	
6	559-16321-01	.PLATE, friction	7	
7	2A6-16324-00	.PLATE, clutch 1	6	
8	307-16367-00	.RING, cushion	6	
9	132-16351-00	.PLATE, Pressure 1	1	
10	90501-20122	.SPRING, compression	5	
11	90119-05001	.BOLT, with washer	5	
12	90179-16018	NUT	1	
13	90215-16020	WASHER, lock	1	
14	382-16111-62	GEAR, Primary drive (19T)	1	
15	90170-12060	NUT	1	
16	90208-12015	WASHER, conical spring	1	
17	174-16164-00	PLATE, thrust 2	2	
18	90387-20439	COLLAR	1	
19	137-16356-00	ROD, Push 1	1	
20	93501-04011	BALL	1	
21	248-16357-00	ROD, Push 2	1	
22	93109-07024	OIL SEAL	1	
23	241-16341-01	SCREW, Push	1	
24	90113-06013	BOLT, set	1	
25	241-16342-00	LEVER, Push	1	
26	95301-06700	NUT	1	
27	90506-10019	SPRING, tension	1	
28	132-16346-00	HOOK, spring	1	



4M3700-0110

B13

FIG. 11 CLUTCH

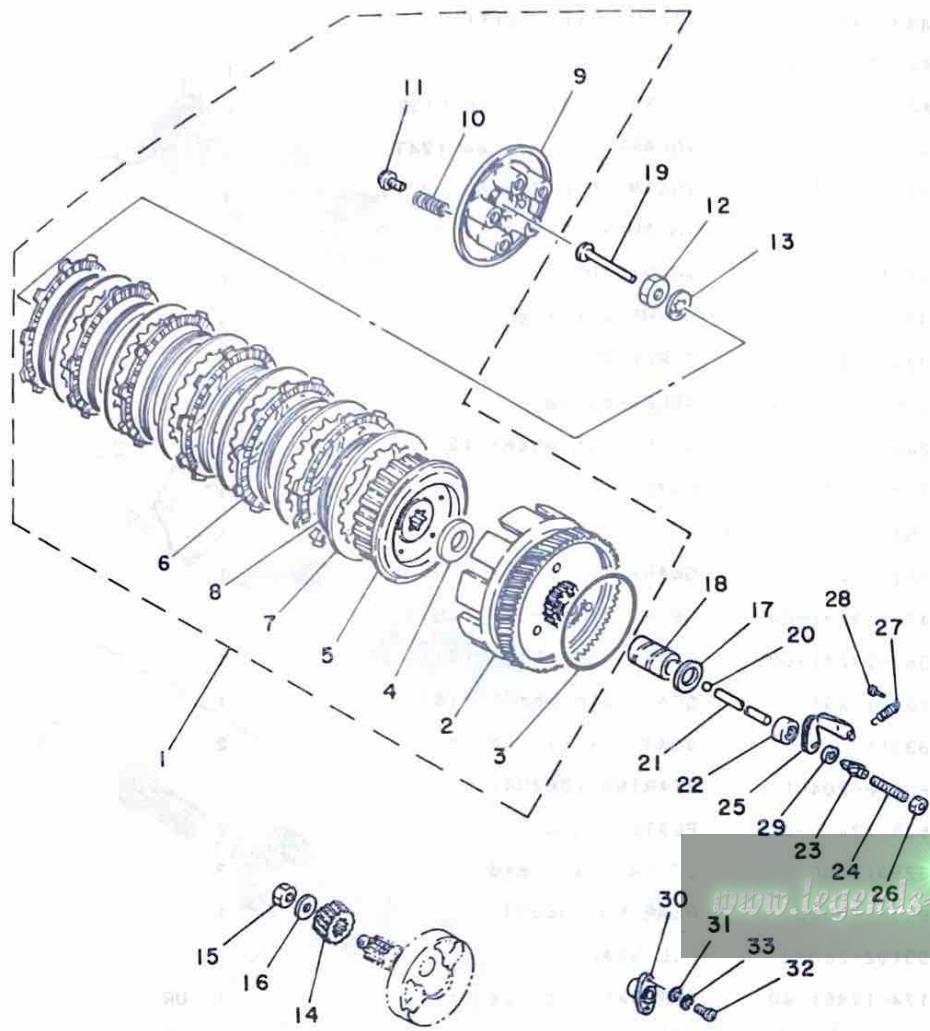

REF. NO.	PART NO.	DESCRIPTION	Q'TY	REMARKS
29	93104-11028	OIL SEAL	1	
30	314-16396-01	HOUSING, Push screw	1	
31	92901-06600	WASHER, Plate	2	
32	92501-06015	SCREW, Pan head	2	
33	92901-06100	WASHER, sPring	2	



4M3700-0110

B14

FIG. 12 TRANSMISSION

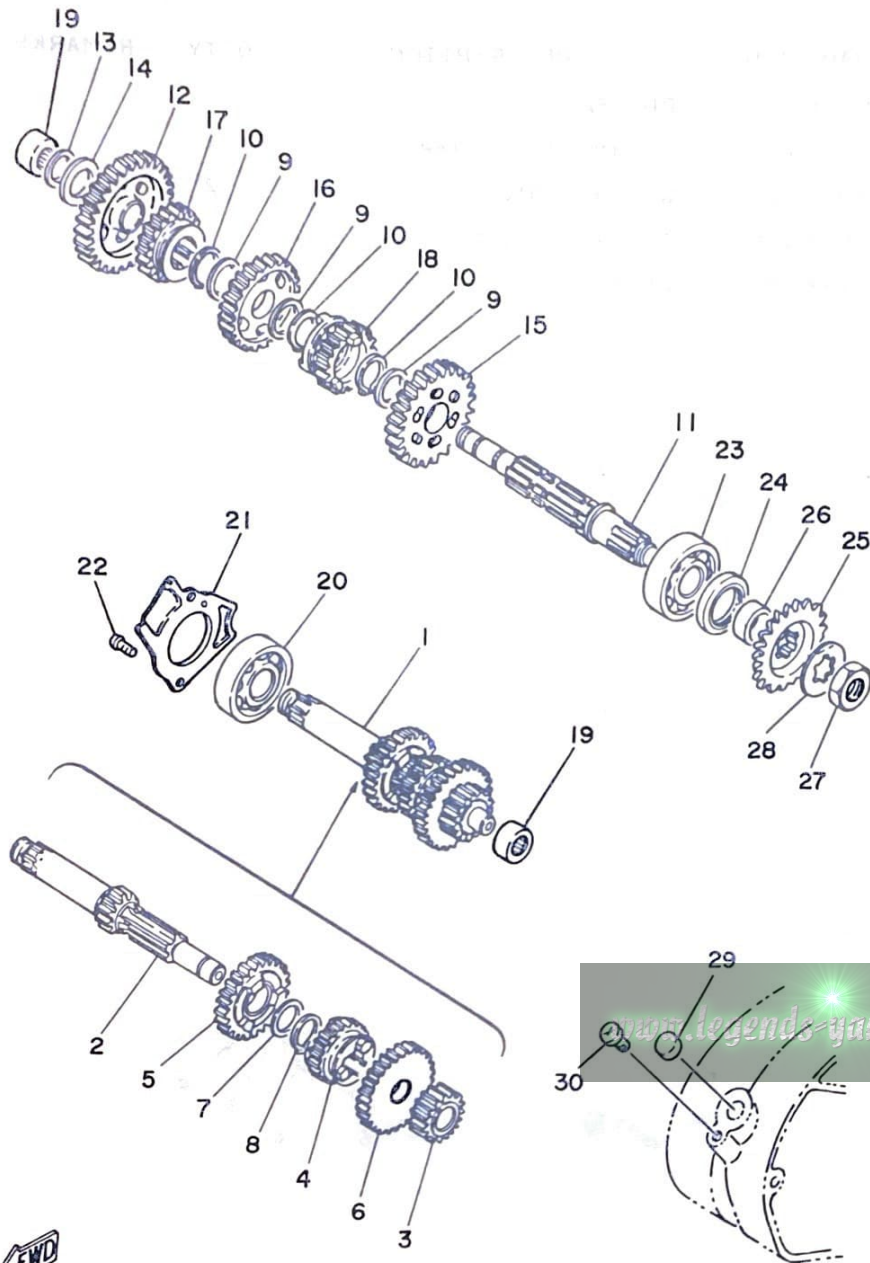

REF. NO.	PART NO.	DESCRIPTION	Q'TY	REMARKS
1	482-17410-00	MAIN AXLE COMP.	1	
2	443-17411-00	•AXLE, main (11T)	1	
3	437-17121-01	•GEAR, 2nd Pinion (15T)	1	
4	427-17131-00	•GEAR, 3rd Pinion (19T)	1	
5	482-17141-00	•GEAR, 4th Pinion (24T)	1	
6	482-17151-00	•GEAR, 5th Pinion (27T)	1	
7	90201-20266	•WASHER, Plate	1	
8	93410-20038	•CIRCLIP	1	
9	90201-20266	WASHER, Plate	3	
10	93410-20038	CIRCLIP	3	
11	315-17421-01	AXLE, drive	1	
12	248-17211-00	GEAR, 1st wheel (35T)	1	
13	93440-15012	CIRCLIP	1	
14	164-17427-00-10	SHIM 1 (1.0T)	1	
15	427-17221-00	GEAR, 2nd wheel (30T)	1	
16	427-17231-00	GEAR, 3rd wheel (26T)	1	
17	382-17241-60	GEAR, 4th wheel (21T)	1	
18	482-17251-00	GEAR, 5th wheel (18T)	1	
19	93311-31515	BEARING, cylindrical	2	
20	93306-20401	BEARING (B6204)	1	
21	525-17471-00	PLATE, cover	1	
22	92501-06012	SCREW, Pan head	2	
23	93306-30401	BEARING (B6304)	1	
24	93102-26042	OIL SEAL	1	
25	174-17461-40	SPROCKET, drive (14T)	1	UR
	174-17461-50	SPROCKET, drive (15T)	1	UR
	174-17461-60	SPROCKET, drive (16T)	1	UR



4M3700-0120

B15

FIG. 12 TRANSMISSION

REF. NO.	PART NO.	DESCRIPTION	Q'TY	REMARKS
26	90387-20491	COLLAR	1	
27	90179-16018	NUT	1	
28	90215-16020	WASHER, lock	1	
29	90338-16029	PLUG	1	
30	92501-06010	SCREW, Pan head	1	

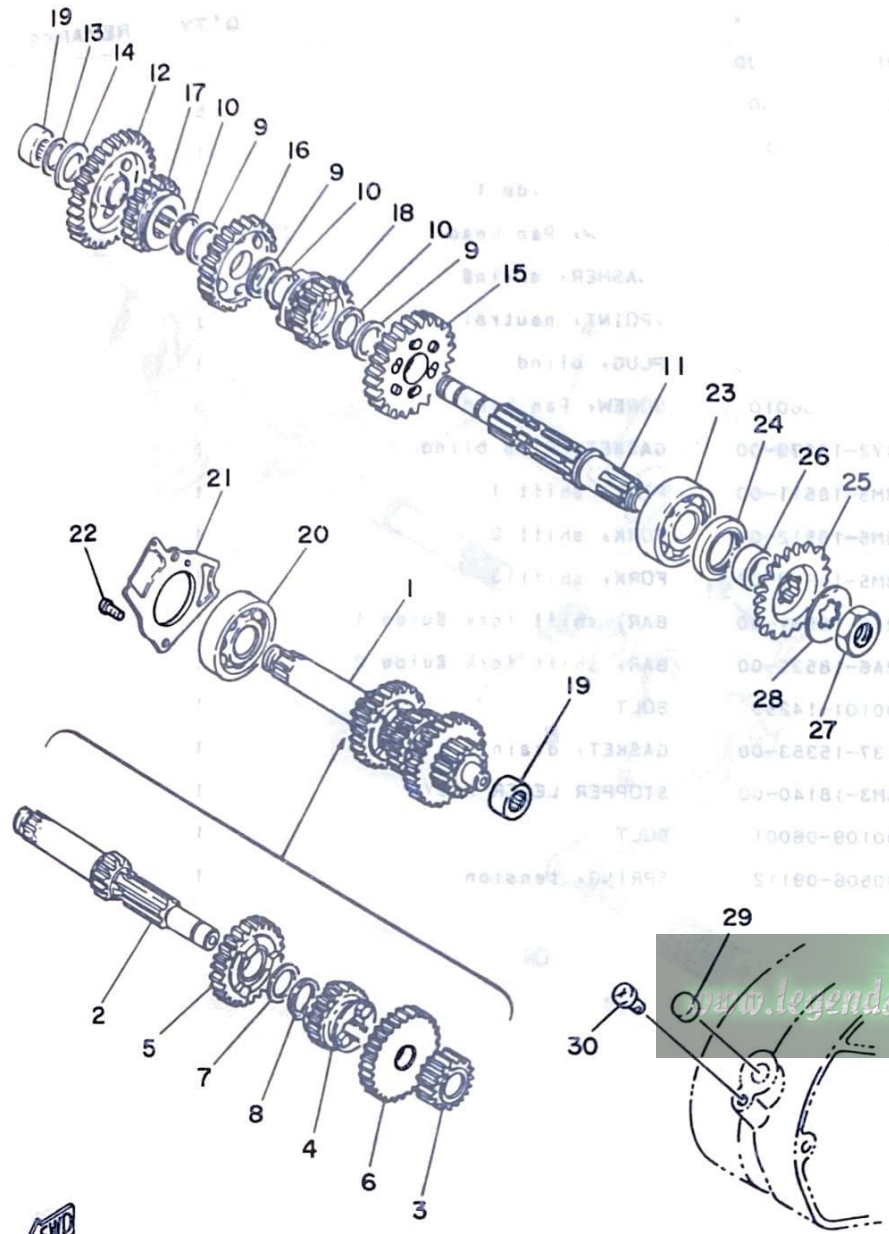

4M3700-0120



FIG. 13 SHIFT CAM FORK

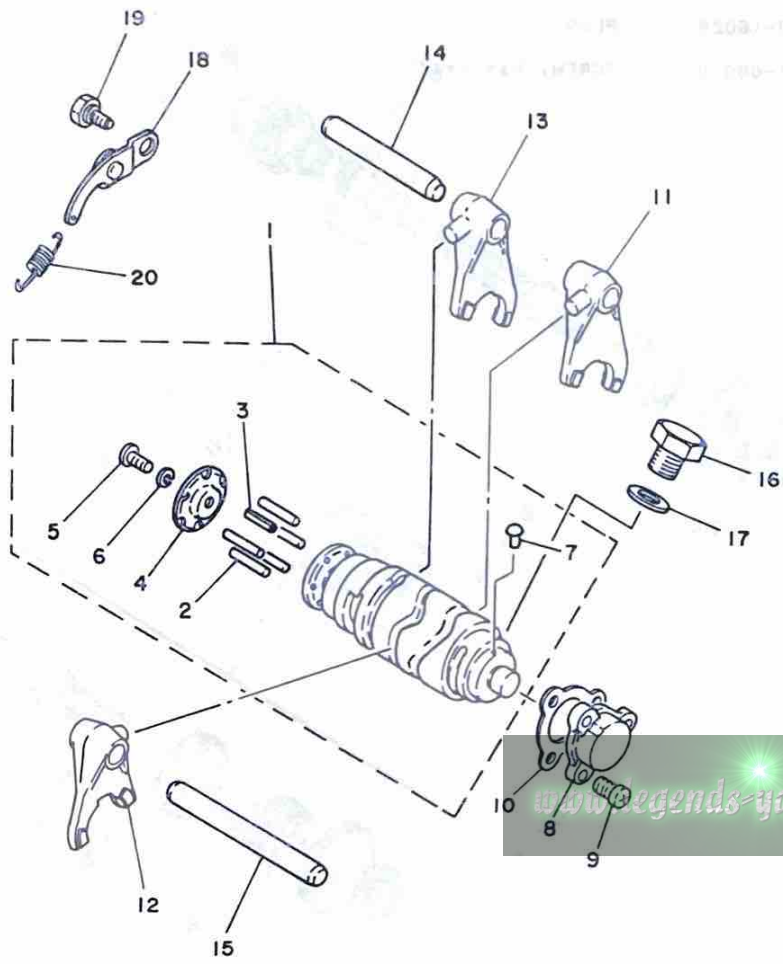

REF. NO.	PART NO.	DESCRIPTION	Q'TY	REMARKS
1	4M3-18540-00	SHIFT CAM ASSY	1	
2	93604-22050	.PIN, dowel	5	
3	91609-40016	.PIN, sPring	1	
4	382-18561-60	.PLATE, side 1	1	
5	98501-05012	.SCREW, Pan head	1	
6	92901-05100	.WASHER, sPring	1	
7	136-18542-00	.POINT, neutral	1	
8	164-18589-00	PLUG, blind	1	
9	92501-06010	SCREW, Pan head	3	
10	4Y2-18579-00	GASKET, Plug blind	1	
11	3M5-18511-00	FORK, shift 1	1	
12	3M5-18512-00	FORK, shift 2	1	
13	3M5-18513-00	FORK, shift 3	1	
14	2A6-18531-00	BAR, shift fork guide 1	1	
15	2A6-18535-00	BAR, shift fork guide 2	1	
16	90101-14259	BOLT	1	
17	137-15353-00	GASKET, drain	1	
18	4M3-18140-00	STOPPER LEVER ASSY	1	
19	90109-06001	BOLT	1	
20	90506-09112	SPRING, tension	1	



4M3700-0130



FIG. 14 SHIFT SHAFT•PEDAL

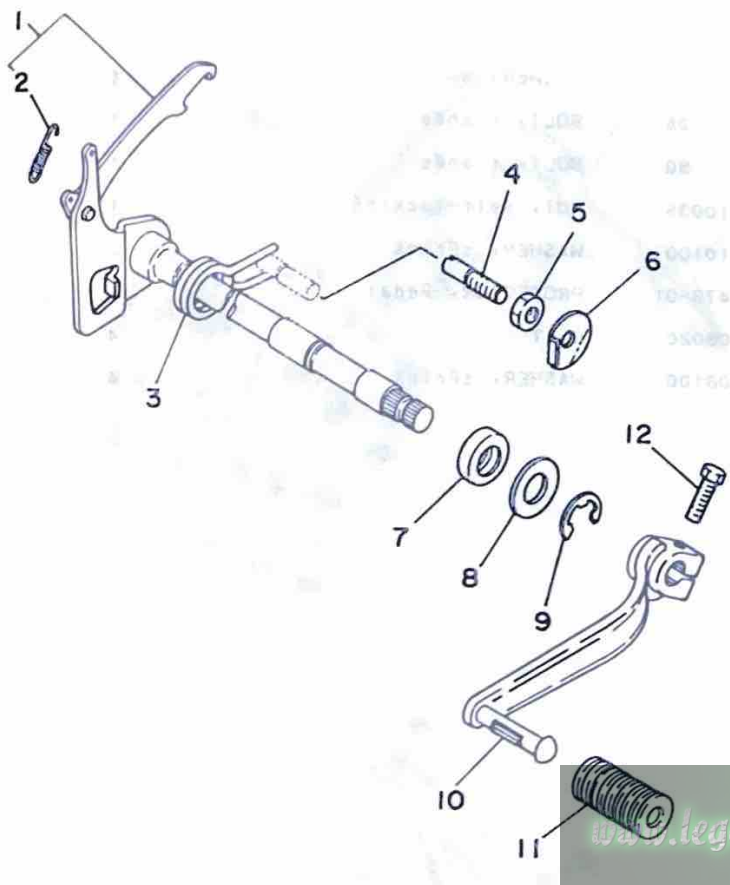

REF. NO.	PART NO.	DESCRIPTION	Q'TY	REMARKS
1	4M3-18101-01	SHIFT SHAFT ASSY	1	
2	90506-09009	•SPRING, tension	1	
3	90508-32437	SPRING, torsion	1	
4	90149-08155	SCREW	1	
5	90170-08029	NUT	1	
6	90215-08014	WASHER, lock	1	
7	93109-14005	OIL SEAL	1	
8	90201-14586	WASHER, Plate	1	
9	93430-12009	CIRCLIP	1	
10	367-18111-00-91	PEDAL, shift	1	uni chrome
11	132-18113-01	COVER, shift Pedal	1	
12	97321-06020	BOLT	1	



FIG. 15 FRAME

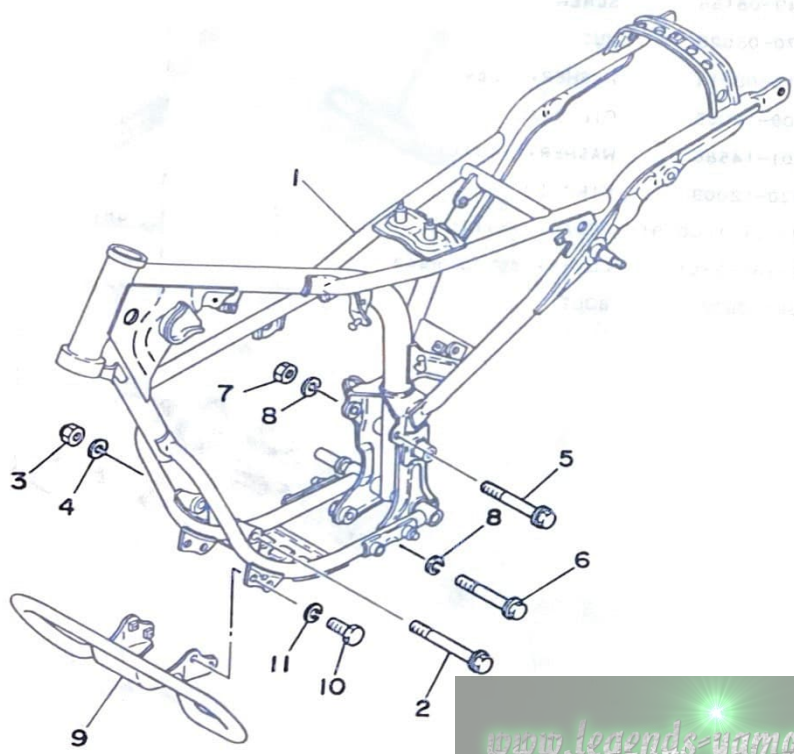

REF. NO.	PART NO.	DESCRIPTION	Q'TY	REMARKS
1	4M3-21110-00-33	FRAME COMP	1	yamaha black for OCEANIA
	4M3-21110-10-33	FRAME COMP	1	yamaha black except OCEANIA
2	95821-08115	BOLT, flange	1	
3	90185-08054	NUT, self-locking	1	
4	92901-08100	WASHER, sPring	1	
5	95821-10105	BOLT, flange	1	
6	95821-10090	BOLT, flange	1	
7	90185-10035	NUT, self-locking	1	
8	92901-10100	WASHER, sPring	2	
9	3V6-21473-01	PROTECTOR, Pedal	1	
10	97301-08020	BOLT	4	
11	92901-08100	WASHER, sPring	4	

www.legends-yamaha-enduros.com



4M3700-0150



FIG. 16 FRONT FENDER-REAR FENDER

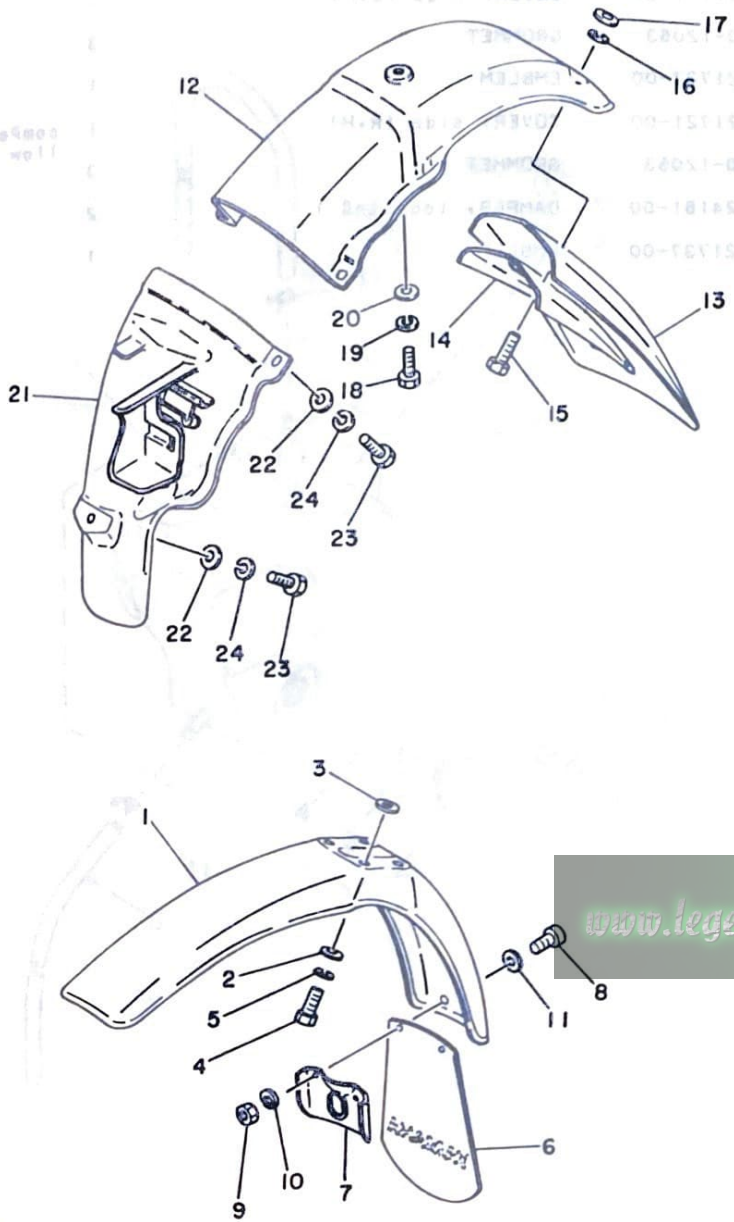

REF. NO.	PART NO.	DESCRIPTION	Q'TY	REMARKS
1	4M3-21511-01	FENDER, front	1	competition yellow
2	90201-06067	WASHER, Plate	4	
3	90209-06187	WASHER	4	
4	97301-06020	BOLT	4	
5	92901-06100	WASHER, sPring	4	
6	4M3-21621-00	FLAP	1	
7	482-21522-00	BAND, flaP	1	
8	92501-06018	SCREW, Pan head	2	
9	95301-06600	NUT	2	
10	92901-06100	WASHER, sPring	2	
11	90201-06067	WASHER, Plate	2	
12	4M3-21611-00	FENDER, rear	1	competition yellow
13	4M3-21621-00	FLAP	1	
14	482-21622-01	BAND, flaP	1	
15	97301-06025	BOLT	2	
16	92901-06100	WASHER, sPring	2	
17	92901-06600	WASHER, Plate	2	
18	97301-06016	BOLT	1	
19	92901-06100	WASHER, sPring	1	
20	90201-06067	WASHER, Plate	1	
21	3V6-21629-01	GUARD, mud	1	
22	90201-06067	WASHER, Plate	3	
23	97301-06020	BOLT	3	
24	92901-06100	WASHER, sPring	3	

www.legends-yamaha-caduros.com

4M3700-0160



FIG. 17 SIDE COVER

REF. NO.	PART NO.	DESCRIPTION	Q'TY	REMARKS
1	4M3-21711-00	COVER, side (L.H)	1	competition yellow
2	90480-12053	GROMMET	3	
3	4M3-21737-00	EMBLEM	1	
4	4M3-21721-00	COVER, side (R.H)	1	competition yellow
5	90480-12053	GROMMET	3	
6	431-24181-00	DAMPER, locating	2	
7	4M3-21737-00	EMBLEM	1	

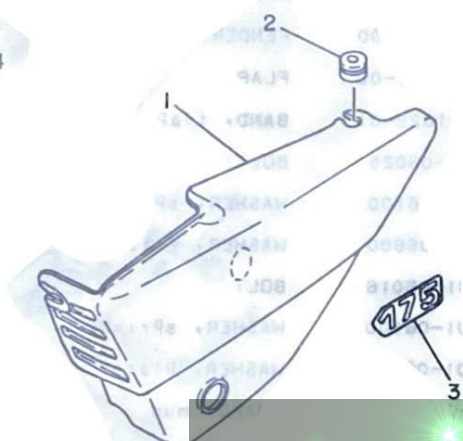
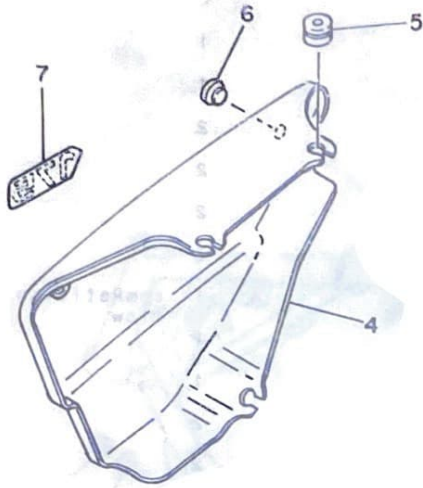

www.legends-yamaha-enduros.com



4M3700-0170

C7

FIG. 18 OIL TANK

REF. NO.	PART NO.	DESCRIPTION	Q'TY	REMARKS
1	3V6-21750-00	OIL TANK ASSY	1	
2	1Y1-21764-00	LENS, level gauge	1	
3	1Y1-2176A-00	REFLECTOR, level gauge	1	
4	1Y1-21763-00	GASKET, level gauge	1	
5	1T9-21771-00	BODY, cap	1	
6	90445-09225	HOSE	1	
7	3V6-21745-00	PIPE, oil tank breather	1	
8	90201-06067	WASHER, plate	2	
9	97301-06016	BOLT	2	
10	92901-06100	WASHER, spring	2	
11	90467-08003	CLIP	2	

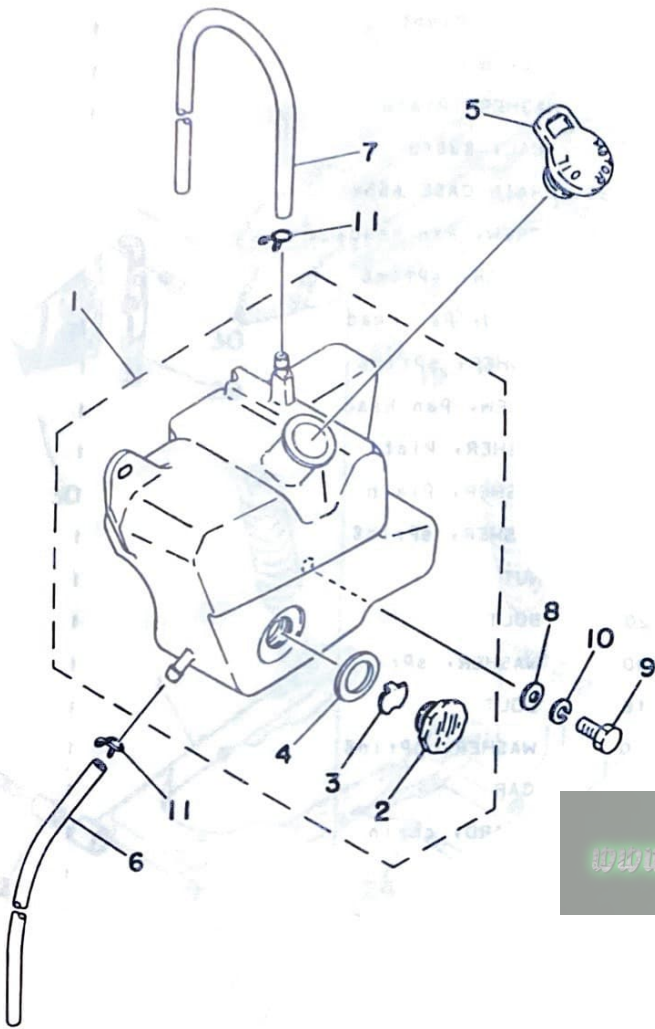

www.legends-yamaha-enduros.com



4M3700-0180

C8

FIG. 19 REAR ARM

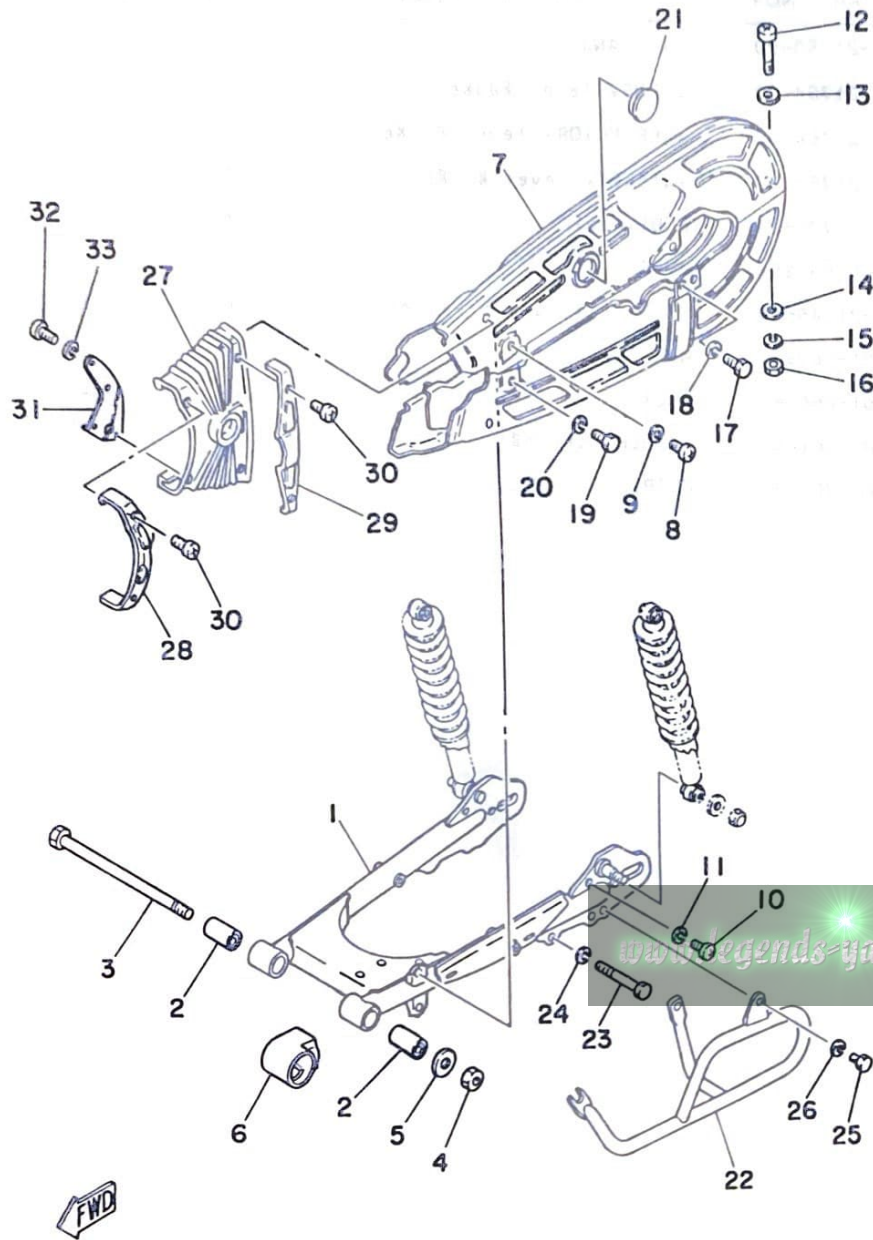

REF. NO.	PART NO.	DESCRIPTION	Q'TY	REMARKS
1	4M3-22110-00-33	REAR ARM COMP.	1	yamaha black
2	174-22123-00	BUSH 1	2	
3	248-22141-00	SHAFT, Pivot	1	
4	95601-14100	NUT, u	1	
5	90201-143A4	WASHER, Plate	1	
6	4M3-22151-00	SEAL, Guard	1	
7	4M3-22310-00-35	CHAIN CASE ASSY	1	silver
8	92501-06012	SCREW, Pan head	1	
9	92901-06100	WASHER, sPrinG	1	
10	92501-06015	SCREW, Pan head	1	
11	92901-06100	WASHER, sPrinG	1	
12	92501-06045	SCREW, Pan head	1	
13	92901-06600	WASHER, Plate	1	
14	92901-06200	WASHER, Plain	1	
15	92901-06100	WASHER, sPrinG	1	
16	95301-06600	NUT	1	
17	97301-08020	BOLT	1	
18	92901-08100	WASHER, sPrinG	1	
19	97301-08016	BOLT	1	
20	92901-08100	WASHER, sPrinG	1	
21	148-22315-00	CAP	1	
22	3V6-22318-01	GUARD, chain	1	
23	90101-08439	BOLT	1	
24	92901-08100	WASHER, sPrinG	1	
25	97301-08016	BOLT	1	
26	92901-08100	WASHER, sPrinG	1	
27	4M3-22325-00	COVER, dust	1	
28	482-22323-01	STAY, dust cover 1	1	

4M3700-0190

FIG. 19 REAR ARM

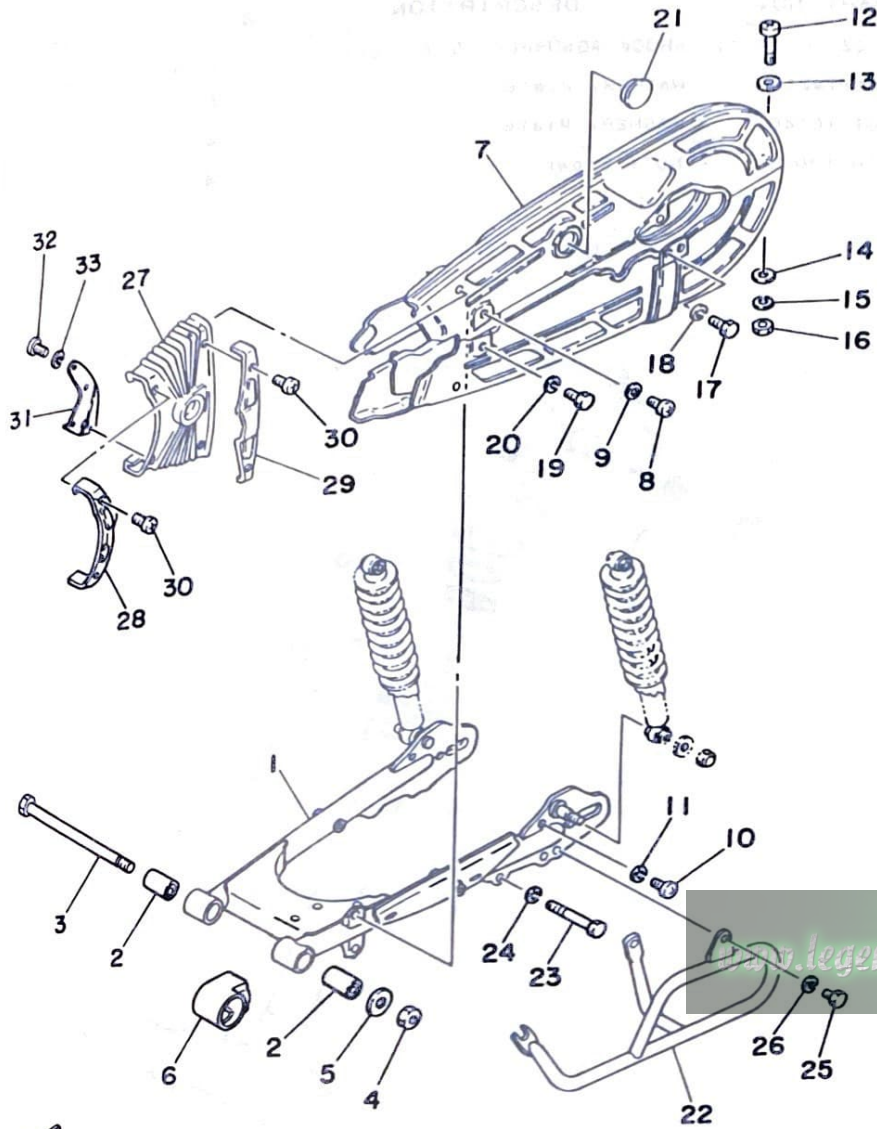

REF. NO.	PART NO.	DESCRIPTION	Q'TY	REMARKS
29	382-22322-00	STAY, chain case 2	1	
30	98501-05008	SCREW, Pan head	4	
31	482-22324-01	STAY, dust cover 3	1	
32	92501-06012	SCREW, Pan head	3	
33	92901-06100	WASHER, sPrInG	3	

FIG. 20 REAR SUSPENSION

REF. NO.	PART NO.	DESCRIPTION	Q'TY	REMARKS
1	4M3-22210-00-33	SHOCK ABSORBER ASSY, rear	2	yamaha black
2	90201-14218	WASHER, Plate	4	
3	90201-10140	WASHER, Plate	4	
4	90176-10013	NUT, crown	4	

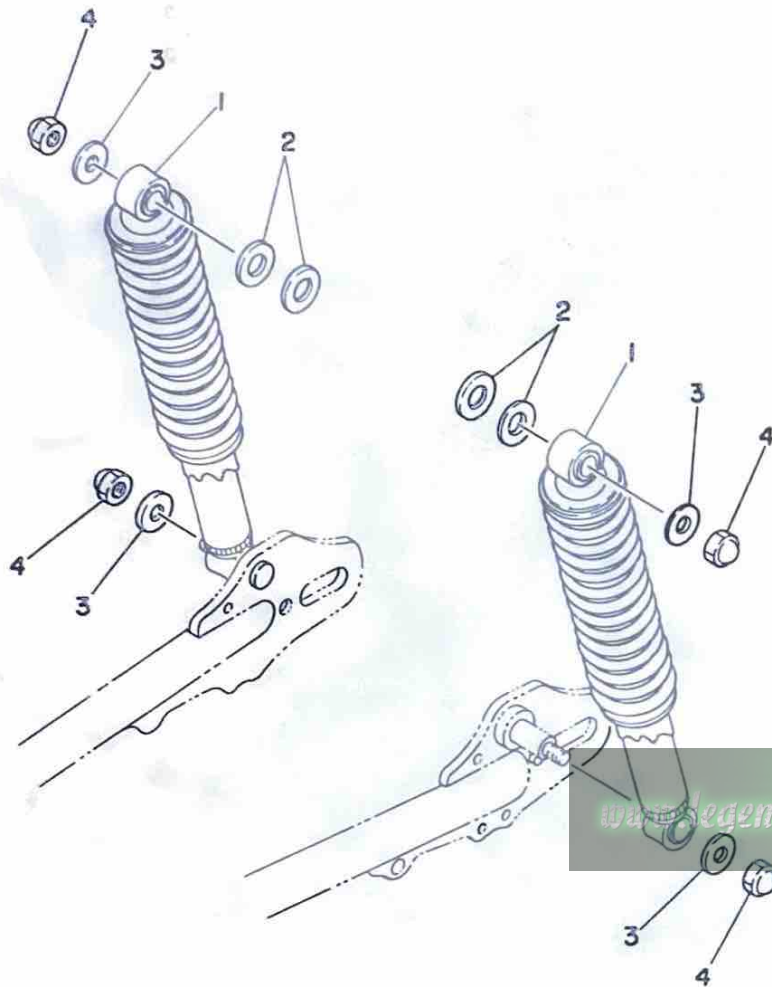

4M3700-1200

C11

FIG. 21 STEERING

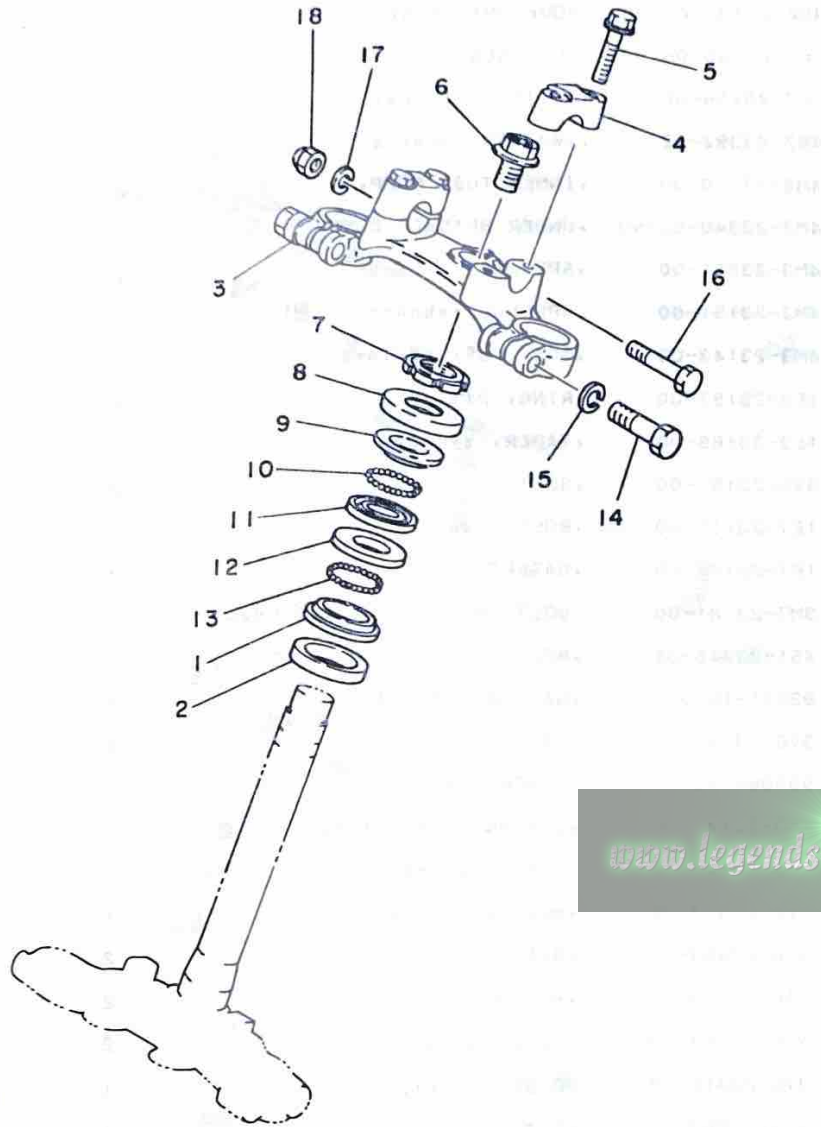

REF. NO.	PART NO.	DESCRIPTION	Q'TY	REMARKS
1	156-23411-00	RACE, ball 1	1	
2	164-23462-00	SEAL, steering	1	
3	3V6-23435-00-33	CROWN, handle	1	yamaha black
4	1E6-23441-00-98	HOLDER, handle upper	2	low gloss black
5	95821-08035	BOLT, flange	4	
6	90105-14136	BOLT, washer based	1	
7	90179-25033	NUT	1	
8	122-23416-00	COVER, ball race 2	1	
9	122-23411-00	RACE, ball 1	1	
10	93503-16010	BALL	22	
11	122-23412-00	RACE, ball 2	1	
12	156-23412-00	RACE, ball 2	1	
13	93501-04011	BALL	19	
14	97301-10040	BOLT	2	
15	92901-10100	WASHER, spring	2	
16	97301-08045	BOLT	1	
17	92901-08100	WASHER, spring	1	
18	95301-08800	NUT, crown	1	

www.legends-yamaha-enduros.com



0H1P33TE IS • FIG. 22 FRONT FORK

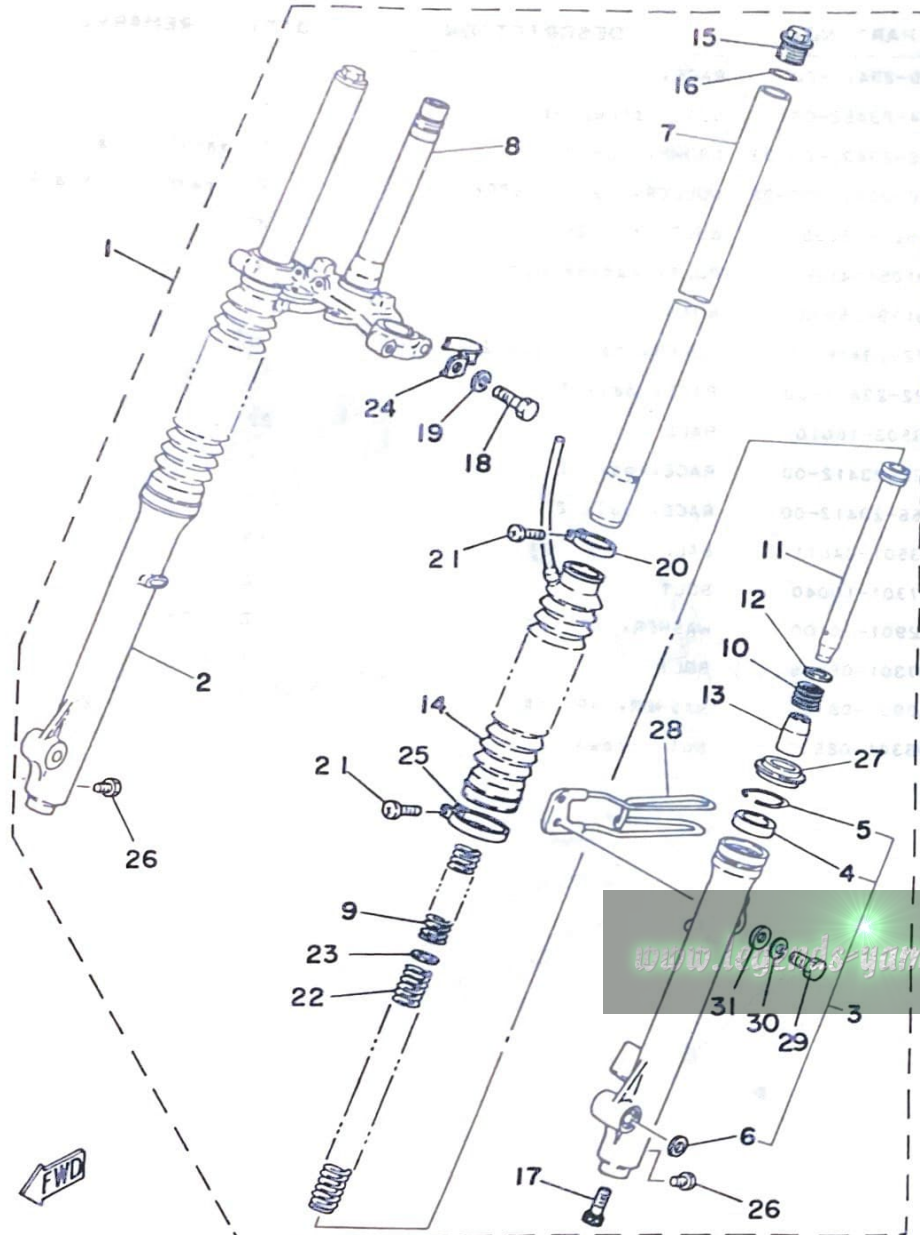

REF. NO.	PART NO.	DESCRIPTION	Q'TY	REMARKS
1	4M3-23101-00	FRONT FORK ASSY	1	
2	3V6-23140-00-35	•FORK UNIT ASSY 2	1	silver
3	3V6-23130-00-35	•FORK UNIT ASSY	1	silver
4	1E7-23145-00	•OIL SEAL	2	
5	1E7-23156-00	•CLIP, oil seal	2	
6	462-23392-02	•WASHER, sPecial	2	
7	4M3-23110-00	•INNER TUBE COMP.1	2	
8	4M3-23340-00-90	•UNDER BRACKET COMP.	1	uni chrome (black)
9	4M3-23351-00	•SPRING	2	
10	4M3-23151-00	•SPRING, rebound	2	
11	4M3-23143-00	•SEAT, sPring lower	2	
12	1E8-23157-00	•RING, Piston	2	
13	1L9-23166-00	•TAPER, sPindle	2	
14	3V6-23191-00	•BOOT	2	
15	1E7-23111-00	•BOLT, caP	2	
16	1E7-23114-00	•GASKET	2	
17	3M7-23181-00	•BOLT, hexaGon socket head	2	
18	451-23346-01	•BOLT 1	2	
19	92901-10100	•WASHER, sPring	2	
20	3V6-23192-01	•BAND	2	
21	98506-04020	•SCREW, Pan head	4	
22	4M3-23141-00	•SPRING, front fork	2	
23	4M3-23142-00	•SEAT, sPring upper	2	
24	3V6-23317-00	•HOLDER, cable	1	
25	3V6-23489-01	•BAND	2	
26	2A6-23119-00	•PLUG, drain	2	
27	3V6-23144-00	•SEAL, dust	2	
28	3V6-23318-00	HOLDER, cable 1	1	
29	97301-06020	BOLT	1	

4M3700-1220

C13

FIG. 22 FRONT FORK

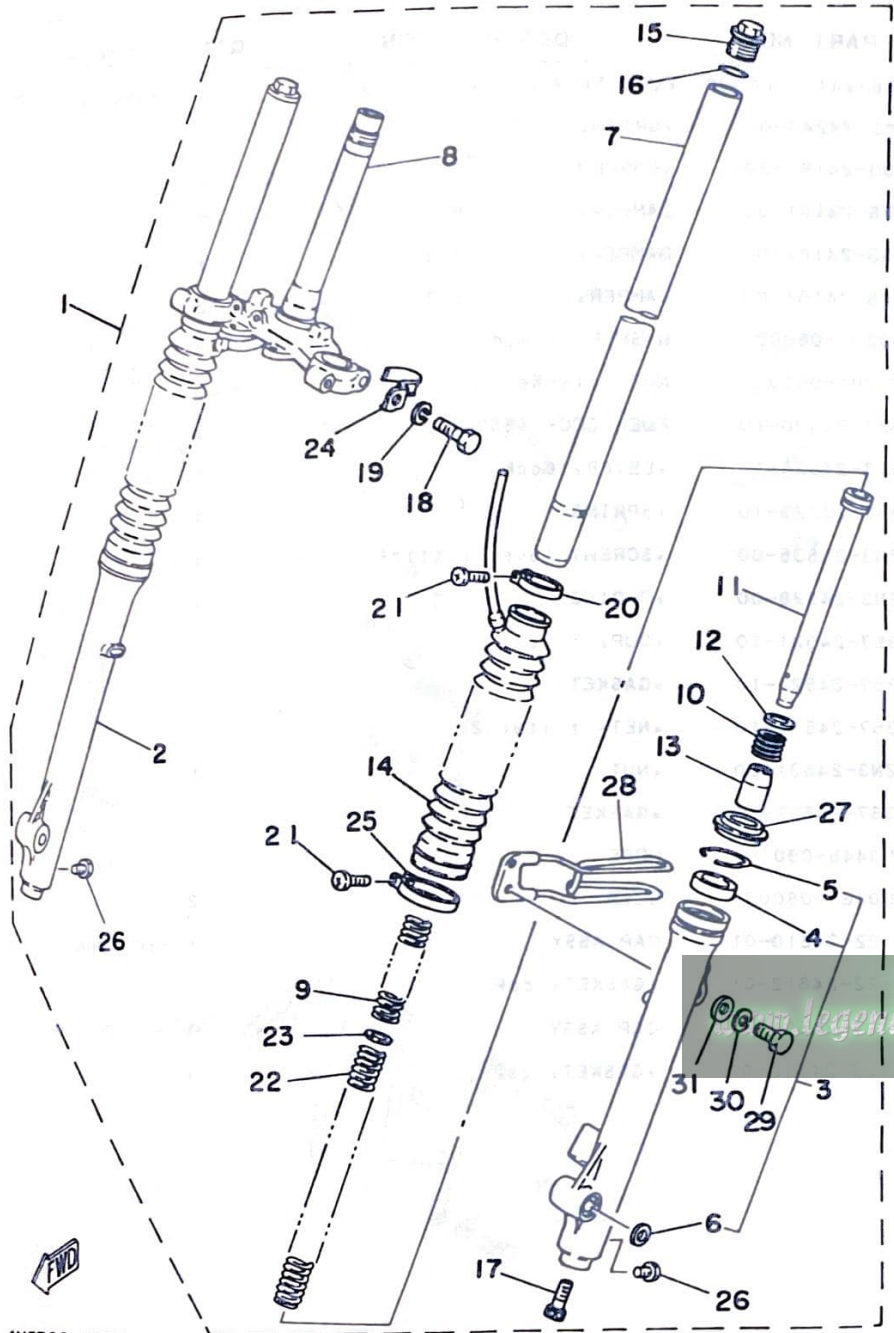

REF. NO.	PART NO.	DESCRIPTION	Q'TY	REMARKS
30	92901-06100	WASHER, sPrinG	1	
31	92901-06600	WASHER, Plate	1	

legends-yamaha-enduros.com

4M3700-1220

C14

FIG. 23 FUEL TANK

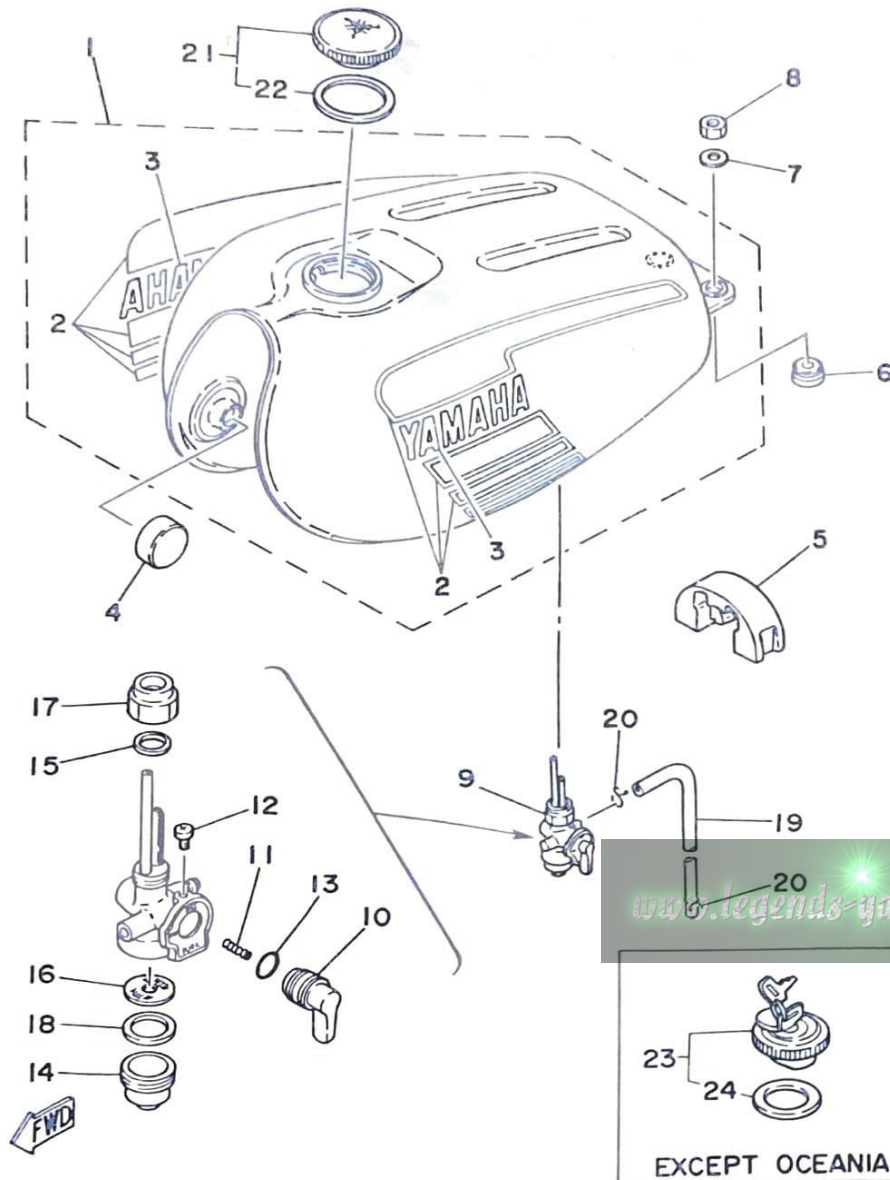

REF. NO.	PART NO.	DESCRIPTION	Q'TY	REMARKS
1	3V6-24110-00-02	FUEL TANK COMP.	1	competition yellow
2	4M3-24240-00	•GRAPHIC SET	1	
3	2J0-24161-20	•EMBLEM 1	2	
4	156-24181-00	DAMPER, locating 1	2	
5	353-24182-00	DAMPER, locating 2	1	
6	1A8-24181-00	DAMPER, locating 1	2	
7	90201-06069	WASHER, Plate	2	
8	95701-06100	NUT, flange	2	
9	357-24500-10	FUEL COCK ASSY 1	1	
10	357-24524-10	•LEVER, cock	1	
11	357-24529-10	•SPRING	1	
12	2N3-24535-00	•SCREW, lever fitting	1	
13	2N3-24528-00	•O-RING	1	
14	357-24521-10	•CUP, filter	1	
15	357-24522-10	•GASKET	1	
16	357-24515-10	•NET, filter 2	1	
17	2N3-24531-00	•NUT	1	
18	357-24532-10	•GASKET	1	
19	90445-09079	HOSE	1	
20	90467-08003	CLIP	2	
21	122-24610-01	CAP ASSY	1	for OCEANIA
22	122-24612-01	•GASKET, cap	1	
23	127-24650-02	CAP ASSY	1	except OCEANIA
24	122-24612-01	•GASKET, cap	1	

4M3700-1230

C15

FIG. 24 SEAT

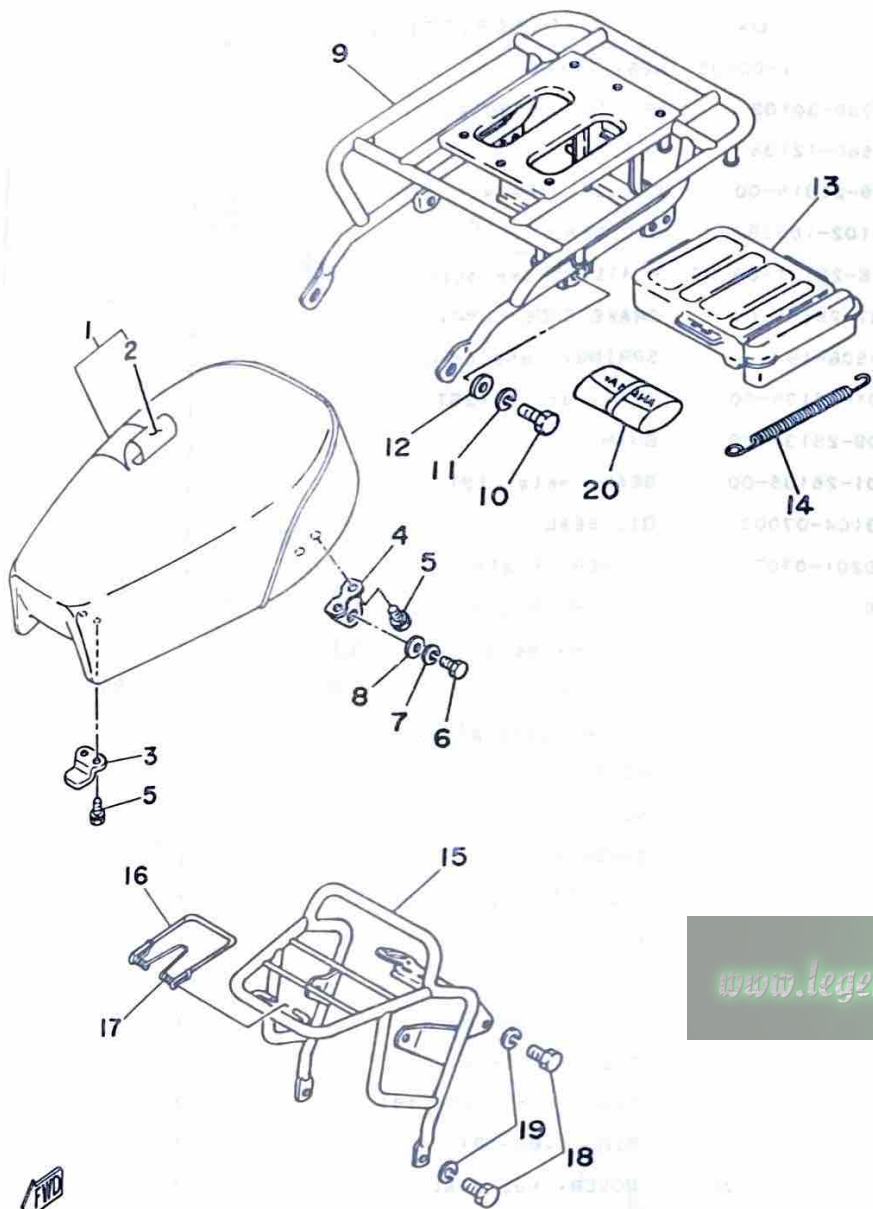

REF. NO.	PART NO.	DESCRIPTION	Q'TY	REMARKS
1	3V6-W2471-01	SINGLE SEAT ASSY	1	
2	3V6-24711-00	COVER, single seat	1	
3	2Y0-24748-00	BRACKET, seat	1	
4	2A6-24738-00	BRACKET, seat	2	
5	90101-06304	BOLT	6	
6	97301-08025	BOLT	2	
7	92901-08100	WASHER, sPring	2	
8	92901-08600	WASHER, Plate	2	
9	3V6-24810-00-93	CARRIER ASSY	1	chrome-Plated
10	97301-08025	BOLT	2	
11	92901-08100	WASHER, sPring	2	
12	92901-08600	WASHER, Plate	2	
13	3V6-21107-01	TOOL BOX COMP.	1	
14	3V6-24758-01	SPRING	1	
15	3V6-24860-01-98	FRONT CARRIER ASSY	1	
16	3V6-24862-00	CLAMP, carrier	1	
17	296-24861-00	SPRING, front carrier	1	
18	97301-08016	BOLT	2	
19	92901-08100	WASHER, sPring	2	
20	3V6-28100-10	TOOL KIT	1	

www.legends-yamaha-enduros.com

FIG. 25 FRONT WHEEL

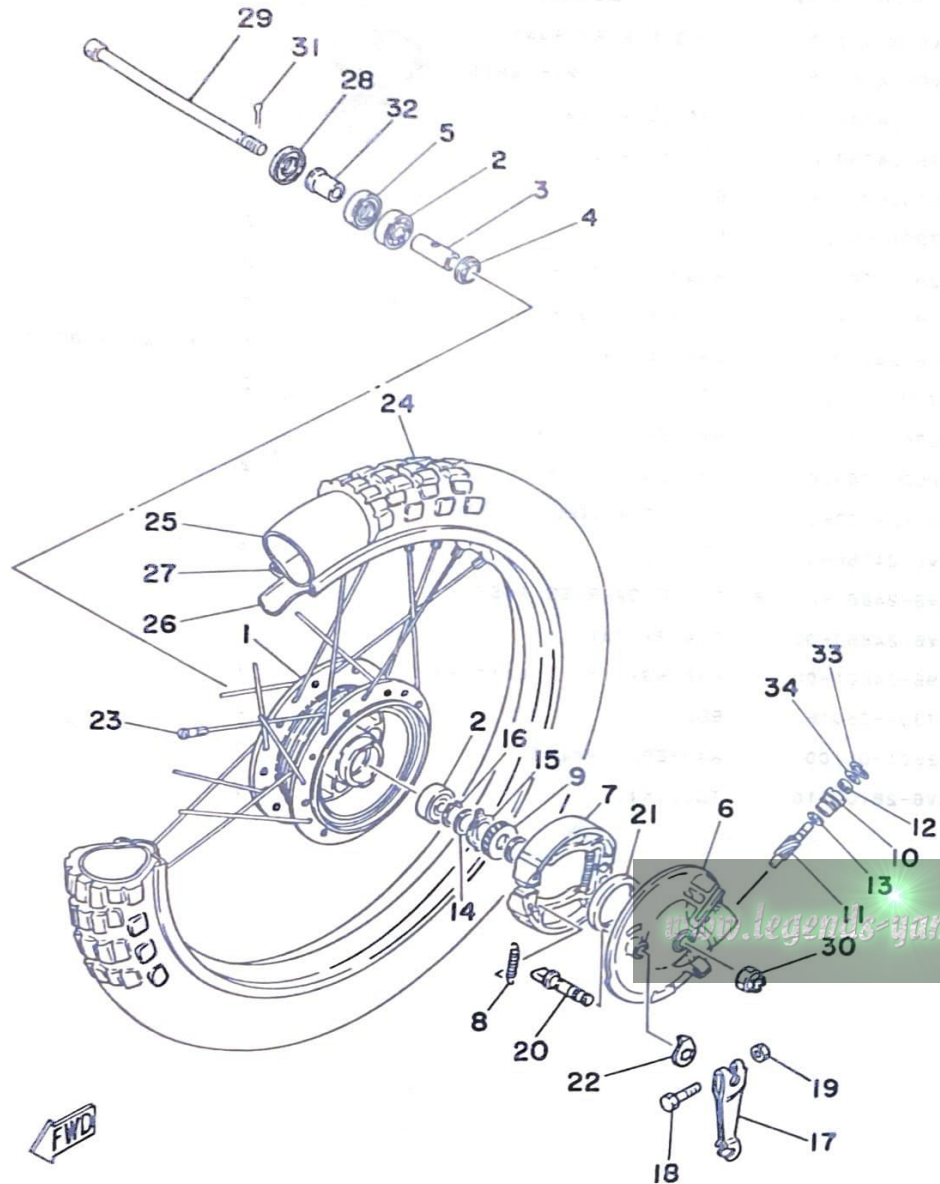

REF. NO.	PART NO.	DESCRIPTION	Q'TY	REMARKS
1	248-25111-00-35	HUB, front	1	silver
2	93306-30103	BEARING (B6301Z)	2	
3	90560-12138	SPACER	1	
4	109-25315-00	FLANGE, sPacer	1	
5	93102-18008	OIL SEAL	1	
6	3V6-25121-00-35	PLATE, brake shoe	1	silver
7	437-25130-00	BRAKE SHOE COMP.	2	
8	90506-16150	SPRING, tension	2	
9	301-25135-00	GEAR, drive (26T)	1	
10	109-25136-00	BUSH	1	
11	301-25138-00	GEAR, meter (9T)	1	
12	93104-07003	OIL SEAL	1	
13	90201-07076	WASHER, Plate	1	
14	90201-20269	WASHER, Plate	2	
15	183-25149-00	CLUTCH, meter	1	
16	93410-20009	CIRCLIP	1	
17	558-25155-00	LEVER, camshaft 1	1	
18	90101-06278	BOLT	1	
19	95301-06600	NUT	1	
20	3V6-25351-00	CAMSHAFT	1	
21	93105-47007	OIL SEAL	1	
22	3E1-2513A-10	PLATE, indicator	1	
23	3V6-25104-00	SPOKE SET, front	1	
24	94130-19629	TIRE (3.00-19)	1	
25	94227-19161	TUBE (2.75-19)	1	
26	94327-19111	BAND, rim (2.75-19)	1	
27	94416-19263	RIM (1.60-19)	1	
28	2K5-25118-00	COVER, hub dust	1	



FIG. 25 FRONT WHEEL

REF. NO.	PART NO.	DESCRIPTION	Q'TY	REMARKS
29	353-25381-00	AXLE, wheel	1	
30	90171-10004	NUT, castle	1	
31	91401-20020	PIN, cotter	1	
32	90387-12265	COLLAR	1	
33	102-25137-00	RING, stop	1	
34	93210-14104	O-RING	1	

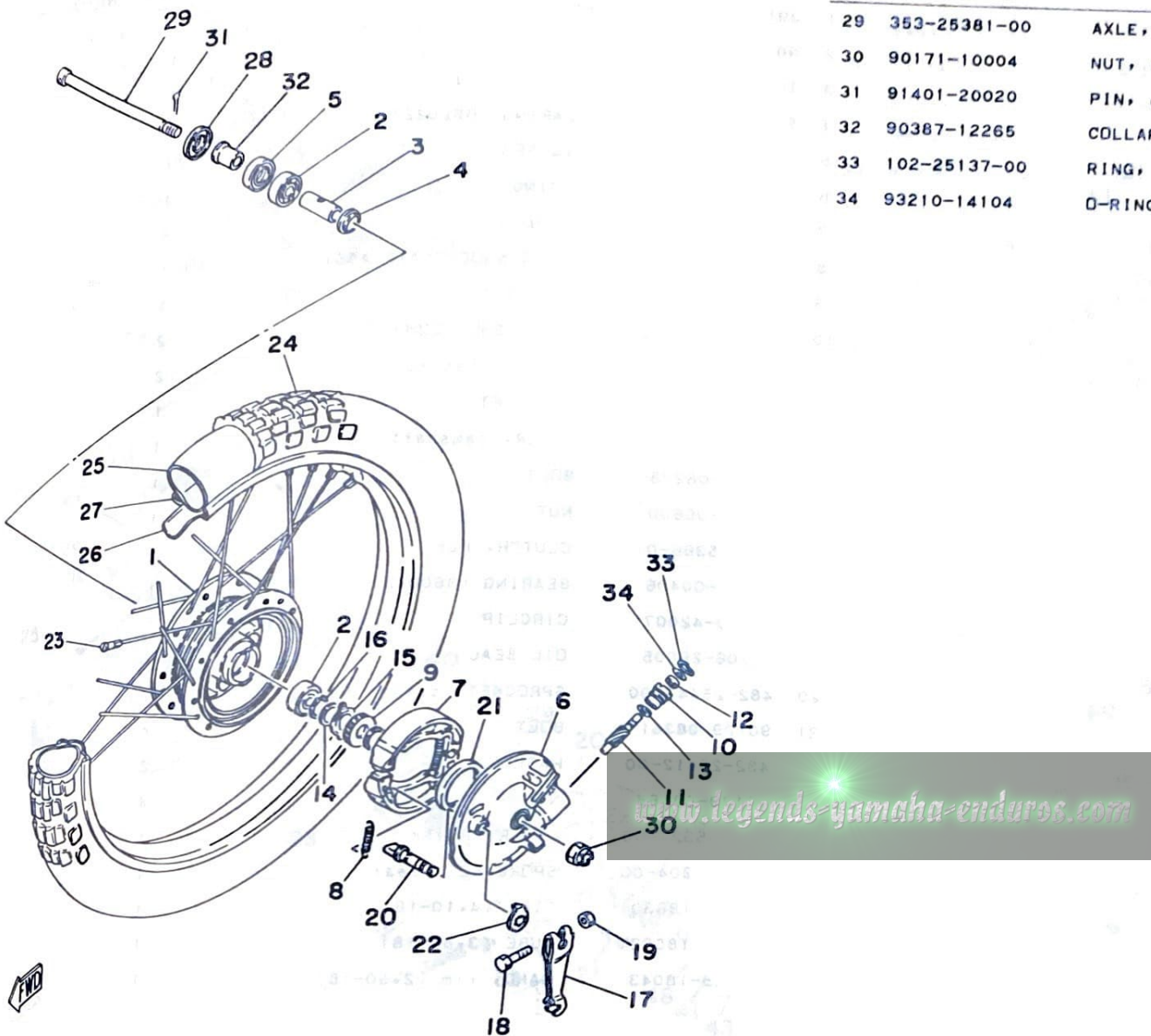

4M3700-0250

D4

FIG. 26 REAR WHEEL

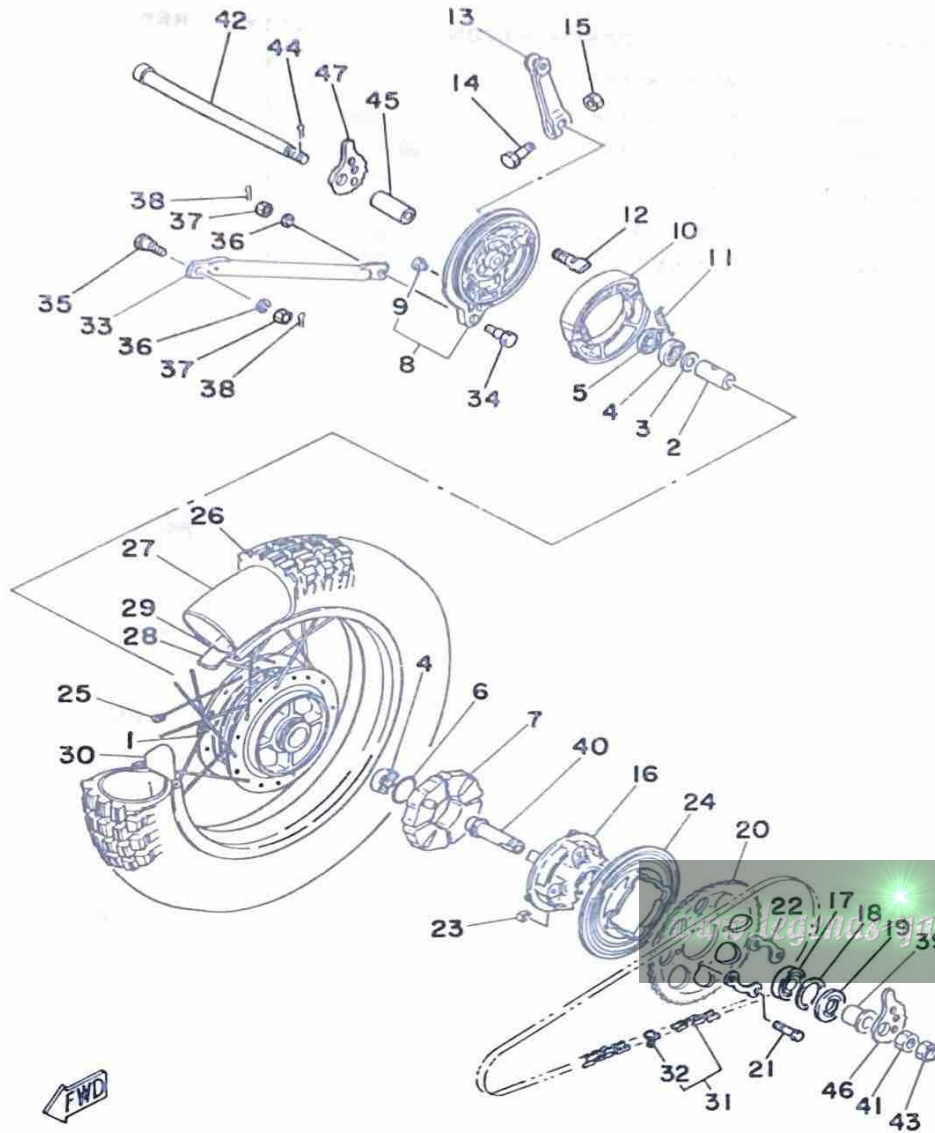

REF. NO.	PART NO.	DESCRIPTION	Q'TY	REMARKS
1	391-25311-00-35	HUB, rear	1	silver
2	90560-15136	SPACER	1	
3	183-25315-00	FLANGE, sPacer	1	
4	93306-20204	BEARING (B6202Z)	2	
5	93104-22018	OIL SEAL	1	
6	93210-42101	O-RING	1	
7	304-25364-01	DAMPER	4	
8	437-25026-10-35	BRAKE SHOE PLATE ASSY	1	silver
9	90480-10068	GROMMET	1	
10	437-25330-00	BRAKE SHOE COMP.	2	
11	90506-16036	SPRING, tension	2	
12	248-25351-00	CAMSHAFT	1	
13	1E7-25355-00	LEVER, camshaft	1	
14	90101-06278	BOLT	1	
15	95301-06600	NUT	1	
16	183-25366-01	CLUTCH, hub	1	
17	93306-00406	BEARING (B6004Z)	1	
18	93420-42007	CIRCLIP	1	
19	93106-26005	OIL SEAL	1	
20	482-25447-00	SPROCKET, driven (47T)	1	
21	90109-08361	BOLT	4	
22	482-25412-00	WASHER	2	
23	90179-08168	NUT	4	
24	3V6-25327-00	COVER, Plate	1	
25	3V6-25304-00	SPOKE SET, rear	1	
26	94141-18630	TIRE (4.10-18)	1	
27	94235-18022	TUBE (3.50-18)	1	
28	94325-18043	BAND, rim (2.50-18)	1	

4M3700-0260

D5

FIG. 26 REAR WHEEL

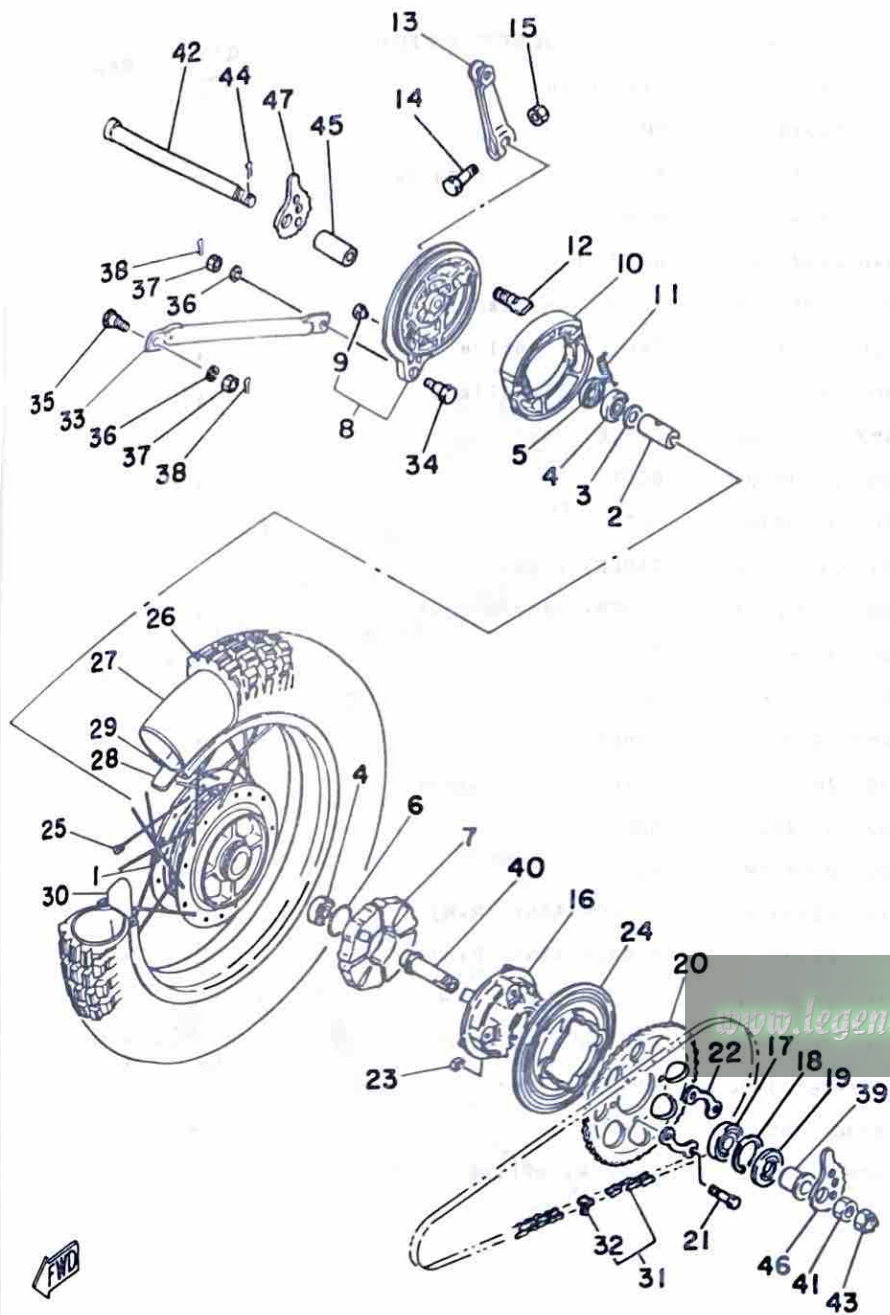

REF. NO.	PART NO.	DESCRIPTION	Q'TY	REMARKS
29	94418-18246	RIM (1.85-18)	1	
30	1T2-25394-00	SPACER, bead	1	
31	94580-30118	CHAIN (DID428HM-118L)	1	
32	94680-30001	JOINT, chain	1	
33	4M3-25371-00	BAR, tension	1	
34	90109-08063	BOLT	1	
35	90109-08368	BOLT	1	
36	92901-08100	WASHER, spring	2	
37	95301-08700	NUT	2	
38	91401-20012	PIN, cotter	2	
39	90387-204A3	COLLAR	1	
40	3V6-25387-00	AXLE, sprocket	1	
41	90170-20224	NUT	1	
42	2A6-25381-00	AXLE, wheel	1	
43	90171-14020	NUT, castle	1	
44	91401-30030	PIN, cotter	1	
45	90387-154A2	COLLAR	1	
46	3V6-25388-00	PULLER, chain 1	1	
47	3V6-25389-00	PULLER, chain 2	1	



4M3700-0260

D6

FIG. 27 HANDLEBAR-CABLE

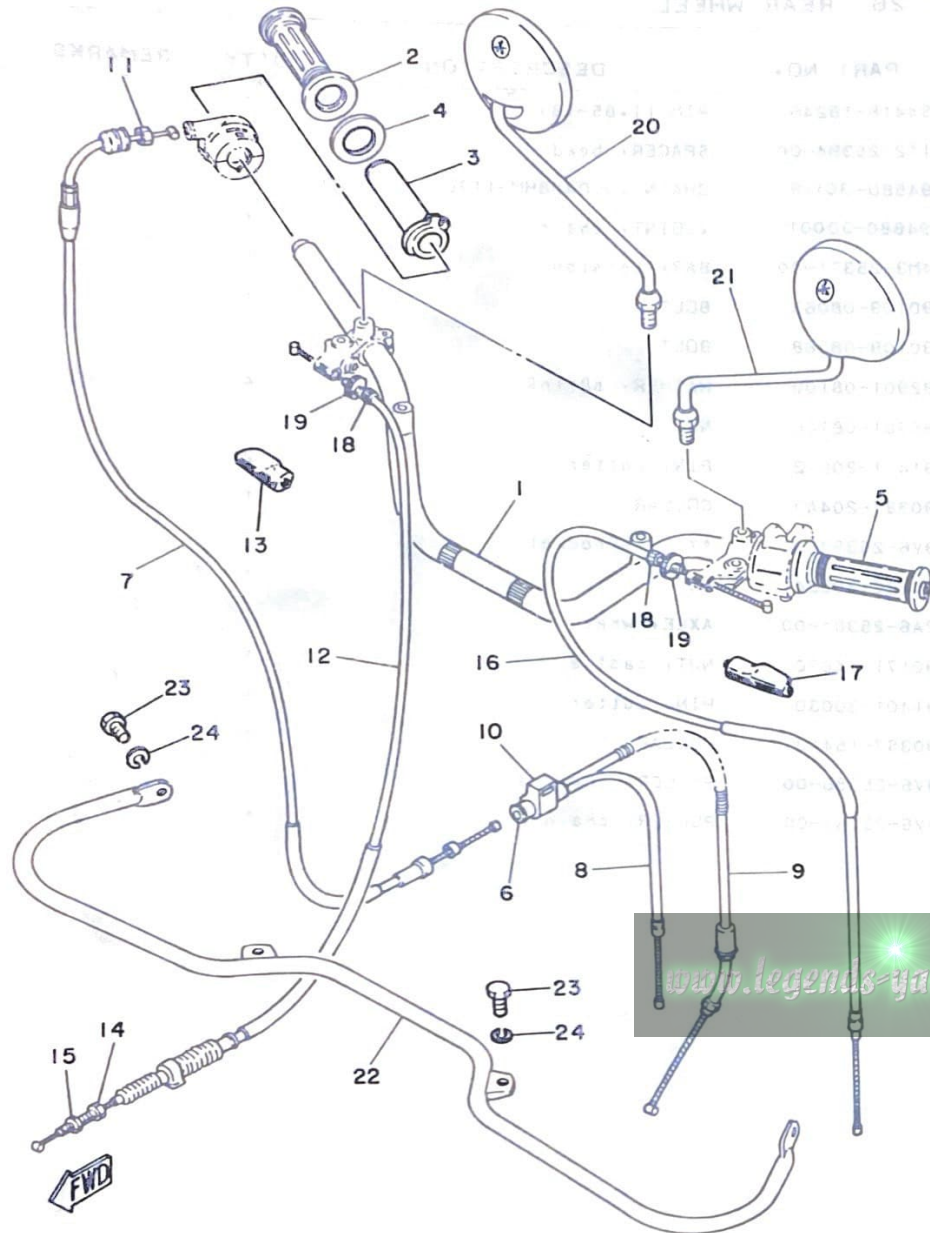

4M3700-0270

D7

REF. NO.	PART NO.	DESCRIPTION	Q'TY	REMARKS
1	4M3-26111-00	HANDLEBAR	1	
2	3V6-26242-00	GRIP (R.H)	1	
3	434-26243-00	TUBE, throttle guide	1	
4	1M1-26249-01	RING, leaf	1	
5	3V6-26241-00	GRIP (L.H)	1	
6	214-26261-00	CONNECTOR, cable	1	
7	3V6-26311-00	CABLE, throttle 1	1	
8	4M3-26312-00	CABLE, throttle 2	1	
9	4M3-26321-00	CABLE, Pump	1	
10	4G3-26339-00	BOOT	1	
11	90170-10038	NUT	1	
12	3V6-26341-00	CABLE, brake	1	
13	382-26372-01	COVER, handle lever	1	
14	90123-06010	BOLT	1	
15	90179-06143	NUT	1	
16	4M3-26335-00	CABLE, clutch	1	
17	382-26372-01	COVER, handle lever	1	
18	90123-08046	BOLT	2	
19	90179-08148	NUT	2	
20	1Y1-26290-40	MIRROR ASSY (R.H)	1	for OCEANIA
	1Y1-26290-00	MIRROR ASSY (R.H)	1	except OCEANIA
21	1Y1-26290-30	MIRROR ASSY (L.H)	1	for OCEANIA
	1Y1-26290-10	MIRROR ASSY (L.H)	1	except OCEANIA
22	3V6-26123-00	GUARD, lever	1	
23	97301-08016	BOLT	4	
24	92901-08100	WASHER, sPring	4	

FIG. 28 STAND-FOOTREST

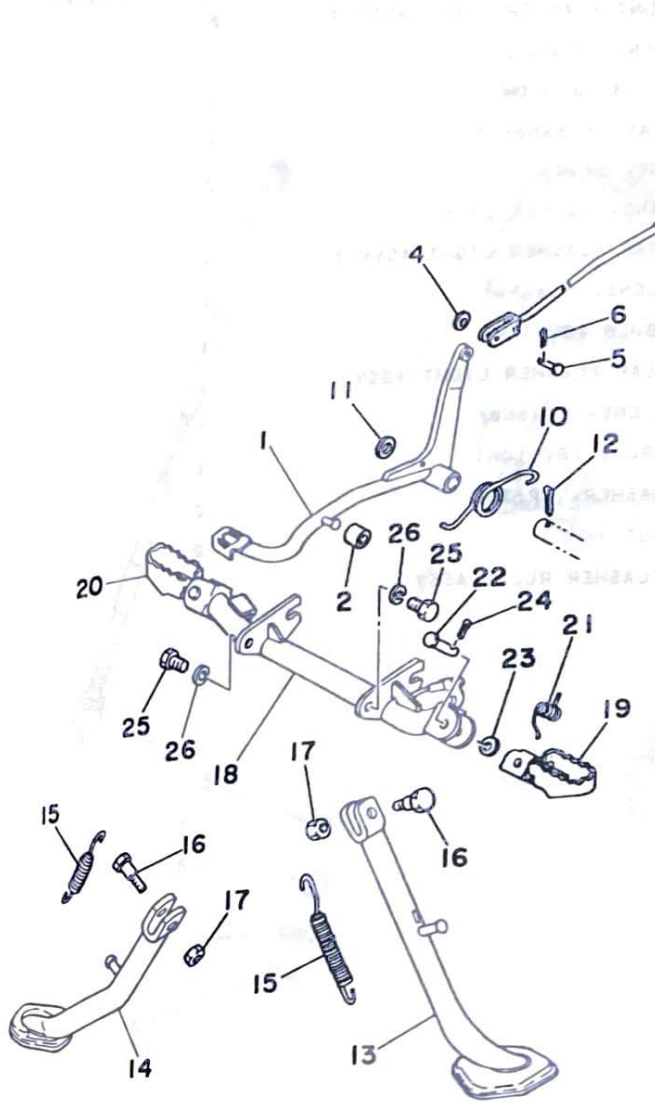

REF. NO.	PART NO.	DESCRIPTION	Q'TY	REMARKS
1	3V6-27211-00-33	PEDAL, brake	1	yamaha black
2	90387-064A4	COLLAR	1	
3	4M3-27231-00	ROD, brake	1	
4	92901-06200	WASHER, Plain	1	
5	90240-06006	PIN, clevis	1	
6	91401-25012	PIN, cotter	1	
7	90501-10245	SPRING, compression	1	
8	90249-12008	PIN	1	
9	90175-06013	NUT, wing	1	
10	90508-35442	SPRING, torsion	1	
11	90201-15564	WASHER, Plate (1.5T)	1	
12	91401-30022	PIN, cotter	1	
13	3V6-27311-00-33	STAND, side	1	yamaha black
14	3V6-27311-10-33	STAND, side	1	yamaha black
15	90506-28100	SPRING, tension	2	
16	90109-10473	BOLT	2	
17	90185-10037	NUT, self-locking	2	
18	3V6-27451-00-33	FOOTREST	1	yamaha black
19	3R1-27411-00	FOOTREST 1	1	uni chrome (black)
20	3R1-27421-00	FOOTREST 2	1	uni chrome (black)
21	90508-20023	SPRING, torsion	2	
22	91701-08038	PIN, clevis	2	
23	92901-08600	WASHER, Plate	2	
24	91401-25012	PIN, cotter	2	
25	97301-10016	BOLT	2	
26	92901-10100	WASHER, sPring	2	

www.legends-yamaha-enduros.com

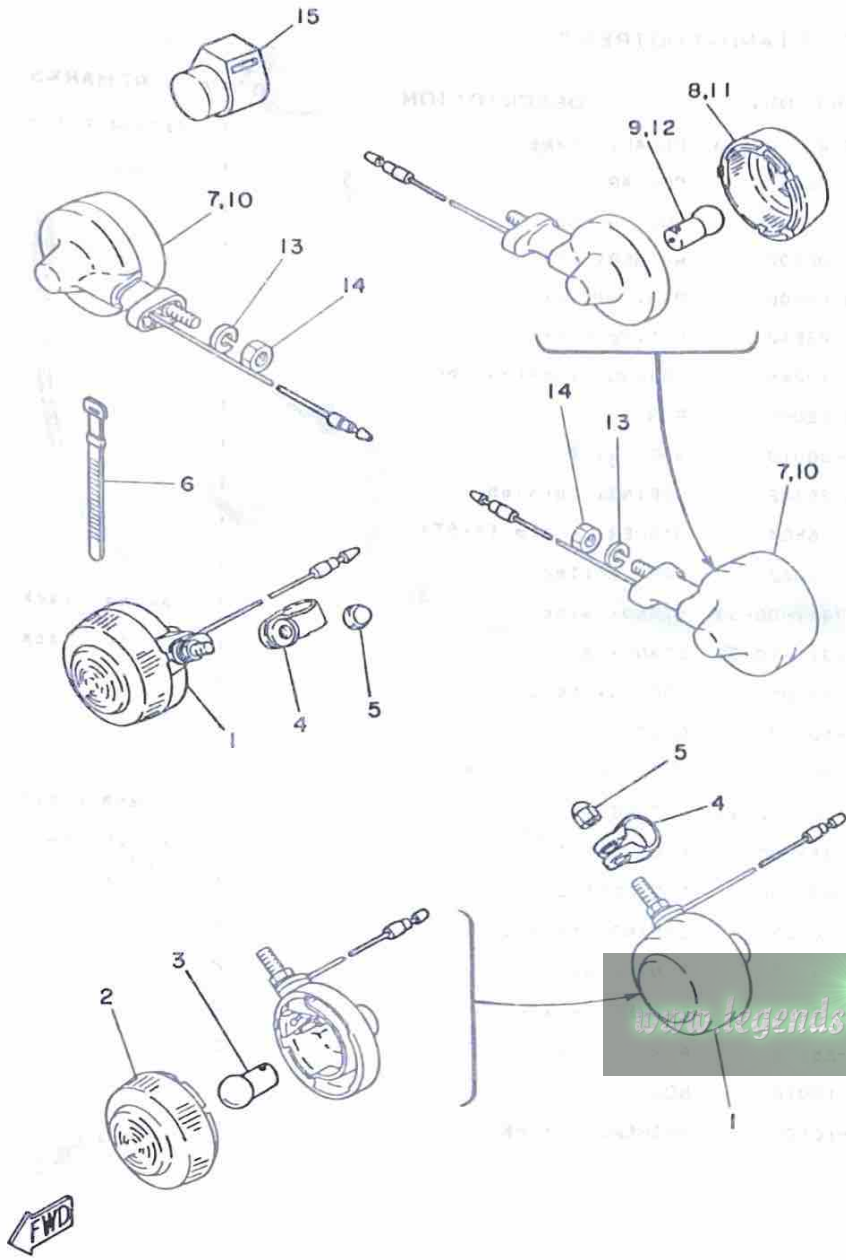

FIG. 29 FLASHER LIGHT

REF. NO.	PART NO.	DESCRIPTION	Q'TY	REMARKS
1	3T2-83310-10	FRONT FLASHER LIGHT ASSY 1	2	
2	3M7-83312-10	•LENS, flasher	1	
3	152-83311-10	•BULB (6V-10W)	1	
4	1M1-83318-00	STAY, flasher 1	2	
5	95303-08800	NUT, crown	2	
6	437-83936-00	BAND, switch cord	1	
7	3T2-83330-10	REAR FLASHER LIGHT ASSY 1	1	
8	3M7-83312-10	•LENS, flasher	1	
9	152-83311-10	•BULB (6V-10W)	1	
10	4G3-83330-10	REAR FLASHER LIGHT ASSY 1	1	
11	3M7-83312-10	•LENS, flasher	1	
12	152-83311-10	•BULB (6V-10W)	1	
13	92901-08100	WASHER, sPrInG	2	
14	95301-08600	NUT	2	
15	3E1-83350-11	FLASHER RELAY ASSY	1	



4M3700-0290



FIG. 30 METER

REF. NO.	PART NO.	DESCRIPTION	Q'TY	REMARKS
1	3F4-83510-F0	SPEEDOMETER ASSY	1	
2	2W0-83520-00	•SOCKET ASSY	1	
3	122-83516-10	•BULB (6V-3W)	2	
4	1M3-83513-00	DAMPER	2	
5	355-83526-00	DAMPER 2	2	
6	355-83522-00	COLLAR	2	
7	355-83524-00	WASHER, sPecial	2	
8	95301-06600	NUT	2	
9	438-83550-01	SPEEDOMETER CABLE ASSY	1	

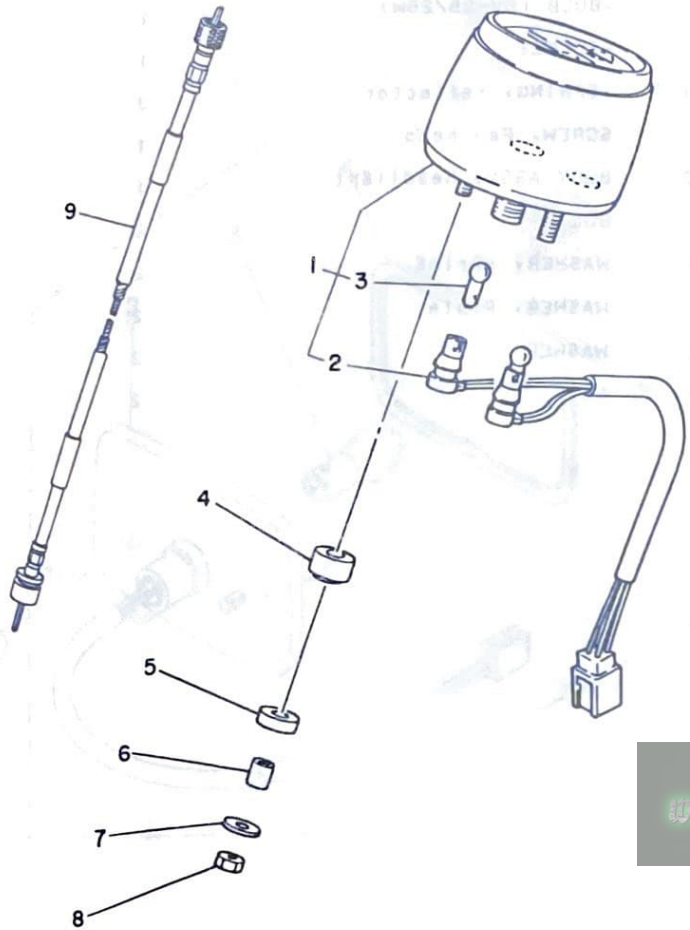

www.legends-yamaha-enduros.com



FIG. 31 HEADLIGHT

REF. NO.	PART NO.	DESCRIPTION	Q'TY	REMARKS
1	3M7-84110-00	HEADLIGHT UNIT ASSY	1	
2	202-84315-00	•RIM, headlight	1	
3	195-84320-00	•LENS ASSY	1	
4	206-84114-60	•BULB (6V-25/25W)	1	
5	317-84112-30	•SOCKET	1	
6	195-84324-00	•SPRING, reflector	3	
7	98501-05008	SCREW, Pan head	1	
8	3M7-84130-00	BODY ASSY, headlight	1	
9	97301-08025	BOLT	2	
10	92901-08100	WASHER, sPring	2	
11	92901-08600	WASHER, Plate	2	
12	92902-08200	WASHER	2	
13	95301-08600	NUT	2	

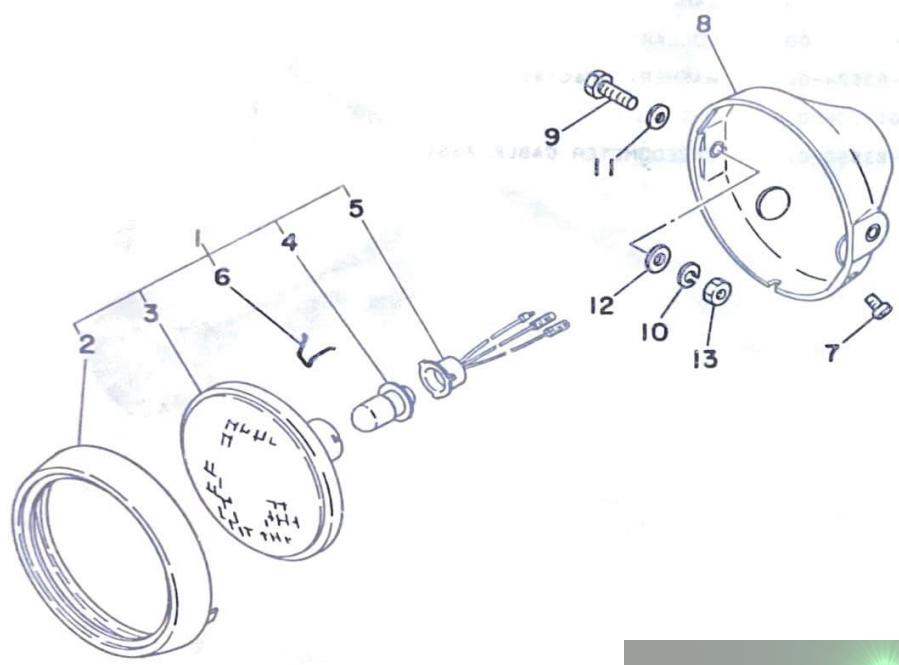

www.legends-yamaha-enduros.com



4M3700-0310

D11

FIG. 32 TAILLIGHT

REF. NO.	PART NO.	DESCRIPTION	Q'TY	REMARKS
1	3T2-84510-00	TAILLIGHT UNIT ASSY	1	
2	3T2-84520-00	.TAILLIGHT BASE ASSY	1	
3	122-84514-30	.BULB (6V-17/5.3W)	1	
4	1K8-84523-00	.GASKET, lens	1	
5	1K8-84521-00	.LENS, taillight	1	
6	2E9-84524-00	.SCREW, lens fitting	2	
7	95701-06100	NUT, flange	2	

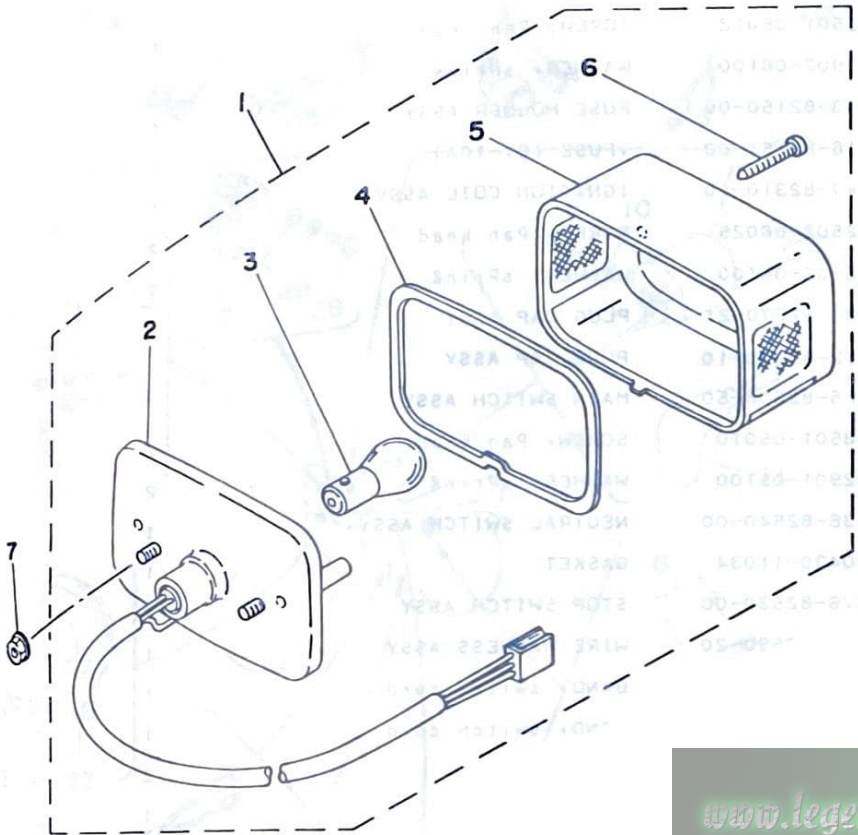

www.legends-yamaha-enduros.com



4M3700-0320

D12

FIG. 33 ELECTRICAL 1

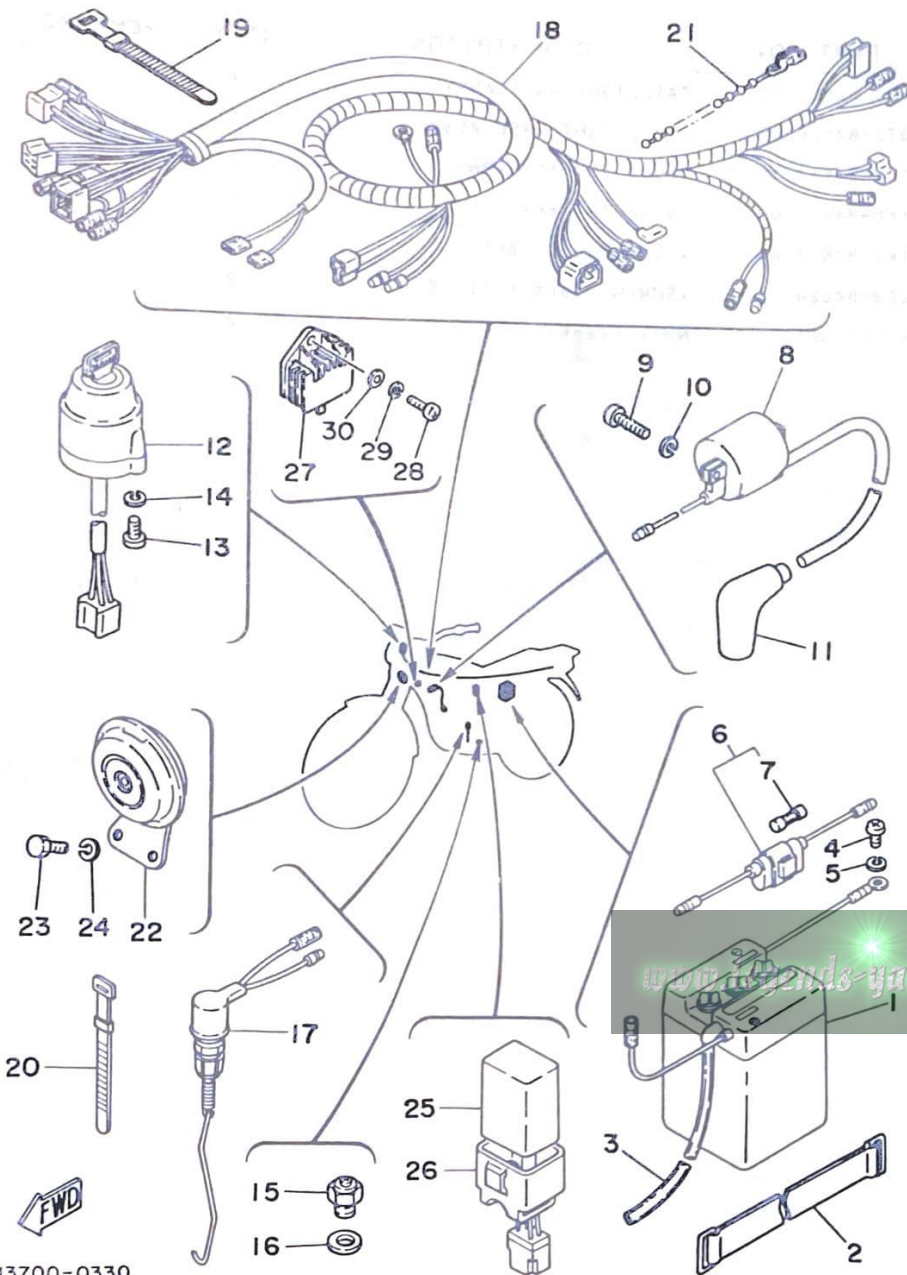

4M3700-0330

REF. NO.	PART NO.	DESCRIPTION	Q'TY	REMARKS
1	120-82110-29	BATTERY ASSY (6N4-2A-2)	1	
2	3V6-82131-00	BAND, battery	1	
3	90445-08338	HOSE	1	
4	92501-06012	SCREW, Pan head	1	
5	92902-06100	WASHER, sPring	1	
6	353-82150-00	FUSE HOLDER ASSY	1	
7	116-82151-00	FUSE (6V-10A)	1	
8	2K7-82310-10	IGNITION COIL ASSY	1	
9	92502-06025	SCREW, Pan head	2	
10	92902-06100	WASHER, sPring	2	
11	437-82370-21	PLUG CAP ASSY	1	
	512-82370-10	PLUG CAP ASSY	1	with noise suppresser
12	2F5-82508-50	MAIN SWITCH ASSY	1	
13	98501-05010	SCREW, Pan head	2	
14	92901-05100	WASHER, sPring	2	
15	136-82540-00	NEUTRAL SWITCH ASSY	1	
16	90430-11034	GASKET	1	
17	3V6-82530-00	STOP SWITCH ASSY	1	
18	4M3-82590-20	WIRE HARNESS ASSY	1	
19	437-83936-00	BAND, switch cord	1	
20	256-83936-00	BAND, switch cord	1	
21	90464-20031	CLAMP	2	
22	2A7-83371-10	HORN	1	
23	97301-06012	BOLT	2	
24	92901-06100	WASHER, sPring	2	
25	482-85540-10	C.D.I. UNIT ASSY	1	
26	2A7-85546-00	BAND	1	
27	4F4-81910-60	VOLTAGE REGULATOR ASSY	1	

D13

FIG. 33 ELECTRICAL 1

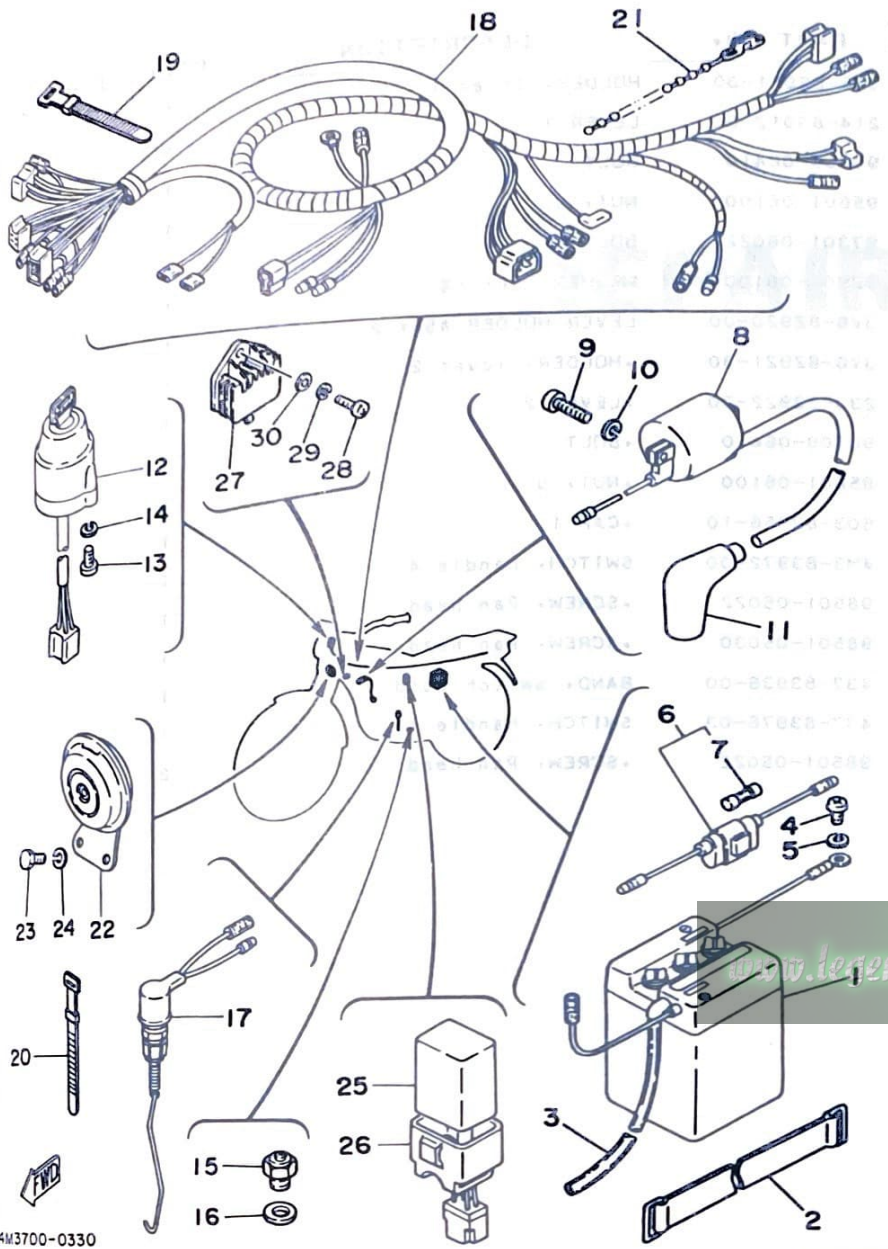

REF. NO.	PART NO.	DESCRIPTION	Q'TY	REMARKS
28	92502-06016	SCREW, Pan head	1	
29	92902-06100	WASHER, sPring	1	
30	92902-06600	WASHER	1	

4M3700-0330

D14

FIG. 34 HANDLE SWITCH-LEVER

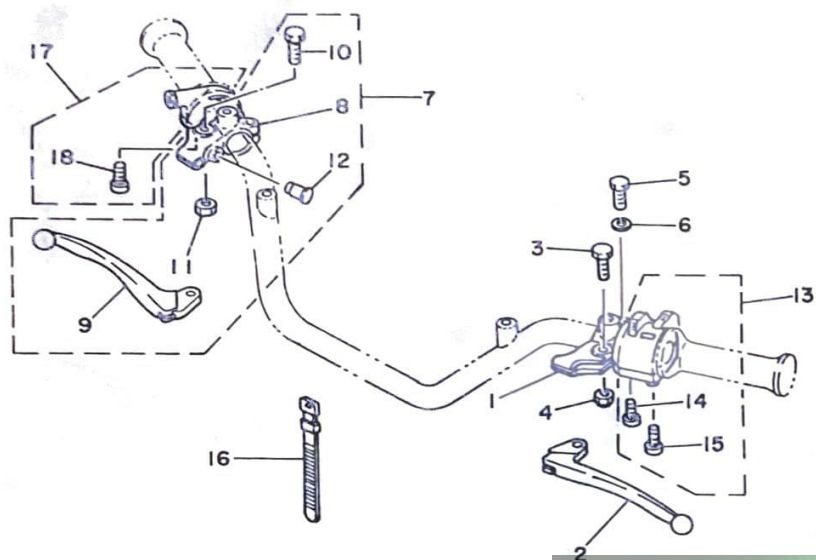

REF. NO.	PART NO.	DESCRIPTION	Q'TY	REMARKS
1	3V6-82911-00	HOLDER, lever 1	1	
2	214-83912-00	LEVER 1	1	
3	90109-06410	BOLT	1	
4	95601-06100	NUT, u	1	
5	97301-06022	BOLT	1	
6	92901-06100	WASHER, spring	1	
7	3V6-82920-00	LEVER HOLDER ASSY 2	1	
8	3V6-82921-30	HOLDER, lever 2	1	
9	233-83922-30	LEVER 2	1	
10	90109-06410	BOLT	1	
11	95601-06100	NUT, u	1	
12	503-83956-10	CAP 1	1	
13	4M3-83972-00	SWITCH, handle 4	1	
14	98501-05022	SCREW, Pan head	1	
15	98501-05030	SCREW, Pan head	1	
16	437-83936-00	BAND, switch cord	1	
17	437-83976-03	SWITCH, handle 1	1	
18	98501-05022	SCREW, Pan head	2	

www.legends-yamaha-enduros.com



4M3700-0340

D15

REPAIR KIT

www.legends-yamaha-enduros.com

FIG. 35 REPAIR KIT

REF. NO.	PART NO.	DESCRIPTION	Q'TY	REMARKS
1	4M3-11630-00	PISTON ASSY (STD)	1	
2	4M3-11631-00-96	•PISTON (STD)	1	
3	4M3-11601-00	•PISTON RING SET (STD)	1	
4	251-11633-00	•PIN, Piston	1	
5	93450-17044	•CIRCLIP	2	
6	4M3-11630-10	PISTON ASSY (1ST O/S)	1	
7	4M3-11635-00	•PISTON (1ST O/S 0.25MM)	1	
8	4M3-11601-10	•PISTON RING SET (1ST O/S)	1	
9	251-11633-00	•PIN, Piston	1	
10	93450-17044	•CIRCLIP	2	
11	4M3-11630-20	PISTON ASSY (2ND O/S)	1	
12	4M3-11636-00	•PISTON (2ND O/S 0.50MM)	1	
13	4M3-11601-20	•PISTON RING SET (2ND O/S)	1	
14	251-11633-00	•PIN, Piston	1	
15	93450-17044	•CIRCLIP	2	
16	4M3-11630-30	PISTON ASSY (3RD O/S)	1	
17	4M3-11637-00	•PISTON (3RD O/S 0.75MM)	1	
18	4M3-11601-30	•PISTON RING SET (3RD O/S)	1	
19	251-11633-00	•PIN, Piston	1	
20	93450-17044	•CIRCLIP	2	
21	4M3-11630-40	PISTON ASSY (4TH O/S)	1	
22	4M3-11638-00	•PISTON (4TH O/S 1.00MM)	1	
23	4M3-11601-40	•PISTON RING SET (4TH O/S)	1	
24	251-11633-00	•PIN, Piston	1	
25	93450-17044	•CIRCLIP	2	
26	2N5-11650-00	CONNECTING ROD ASSY	1	
27	2N4-11651-00	•ROD, connecting	1	

www.legends-yamaha-enduros.com

FIG. 35 REPAIR KIT

REF. NO.	PART NO.	DESCRIPTION	Q'TY	REMARKS
28	3M5-11681-00	.PIN, crank 1	1	
29	90209-22071	.WASHER	2	
30	93310-42231	.BEARING, cylindrical	1	
31	93310-216E1	.BEARING, cylindrical	1	
32	4M3-W0001-00	GASKET KIT	1	
33	1W2-11181-10	.GASKET, cylinder head 1	1	
34	3M5-11351-01	.GASKET, cylinder	1	
35	93210-18023	.O-RING	1	
36	90430-04004	.GASKET	1	
37	126-13116-00	.GASKET, Pump case	1	
38	304-14184-00	.GASKET, float chamber	1	
39	314-13621-02	.GASKET, valve seat	2	
40	3V6-14416-00	.GASKET, air cleaner	1	
41	152-14613-00	.GASKET, exhaust Pipe	1	
42	90430-12038	.GASKET	1	
43	314-15455-00	.GASKET, crankcase cover	1	
44	315-15451-02	.GASKET, crankcase cover	1	
45	444-15456-00	.GASKET, oil Pump cover 1	1	
46	137-15353-00	.GASKET, drain	1	
47	4M3-W0003-00	OIL SEAL KIT	1	
48	93102-25061	.OIL SEAL	1	
49	93103-28011	.OIL SEAL	1	
50	93101-10002	.OIL SEAL	1	
51	93104-20017	.OIL SEAL	1	
52	93109-05022	.OIL SEAL	1	
53	93104-11028	.OIL SEAL	1	
54	93102-26042	.OIL SEAL	1	
55	93109-14005	.OIL SEAL	1	

www.legends-yamaha-enduros.com

INDEX

www.legends-yamaha-enduros.com

NUMERICAL INDEX

PART NO.	REF. NO.	PART NO.	REF. NO.	PART NO.	REF. NO.
92501-06020	5-22	92901-08100	19-20	93210-18023	2- 9
	9-17		19-24		35-35
92501-06030	9- 8		19-26	93210-42101	26- 6
92501-06035	5-20		21-17	93210-89268	11- 3
	9-12		24- 7	93306-00406	26-17
92501-06045	8- 2		24-11	93306-20204	26- 4
	19-12		24-19	93306-20401	12-20
92501-06055	8- 3		26-36	93306-20517	2-12
	9- 7		27-24	93306-30103	25- 2
92501-06060	9-13		29-13	93306-30401	12-23
92501-06065	8- 4		31-10	93306-30405	2-11
	9- 6	92901-08600	24- 8	93310-216E1	2-19
92501-08010	8- 9		24-12		35-31
92502-06016	33-28		28-23	93310-42231	2- 7
92502-06025	33- 9		31-11		35-30
92701-06015	3-16	92901-10100	15- 8	93311-31515	12-19
92901-05100	4-11		21-15	93410-13004	10-14
	7-11		22-19	93410-20009	10- 9
	13- 6		28-26		25-16
	33-14	92901-12100	3-19	93410-20038	12- 8
92901-05600	3-23	92902-04100	6-17		12-10
92901-06100	7-14	92902-06100	33- 5	93410-30012	10- 5
	11-33		33-10	93420-42007	26-18
	16- 5		33-29	93430-08006	4-22
	16-10	92902-06600	33-30	93430-12009	14- 9
	16-16	92902-08200	31-12	93440-11029	10-19
	16-19	93101-10002	4-18	93440-15012	12-13
	16-24		35-50	93450-17044	2-17
	18-10	93102-18008	25- 5		35- 5
	19- 9	93102-25061	2-13		35-10
	19-11		35-48		35-15
	19-15	93102-26042	12-24		35-20
	19-33		35-54		35-25
	22-30	93103-28011	2-14	93501-04011	11-20
	33-24		35-49		21-13
	34- 6	93104-07003	25-12	93503-16010	21-10
92901-06200	19-14	93104-11028	11-29	93505-32002	4- 2
	28- 4		35-53	93603-22028	4-21
92901-06600	5- 9	93104-20017	10-11	93604-22050	13- 2
	5-18		35-51	94130-19629	25-24
	11-31	93104-22018	26- 5	94141-18630	26-26
	16-17	93105-47007	25-21	94227-19161	25-25
	19-13	93106-26005	26-19	94235-18022	26-27
	22-31	93109-05022	35-52	94325-18043	26-28
92901-08100	7-17	93109-07024	11-22	94327-19111	25-26
	15- 4	93109-14005	14- 7	94416-19263	25-27
	15-11		35-55	94418-18246	26-29
	19-18	93210-14104	25-34	94580-30118	26-31

NUMERICAL INDEX

PART NO.	REF. NO.	PART NO.	REF. NO.	PART NO.	REF. NO.
94680-30001	26-32	97321-08030	10-21		
94701-00043	1- 3	97602-03108	5- 4		
95301-05600	4-12	98501-04016	6-16		
95301-06600	7-15	98501-05008	7-10		
	16- 9		19-30		
	19-16		31- 7		
	25-19	98501-05010	33-13		
	26-15	98501-05012	13- 5		
	30- 8	98501-05016	4-17		
95301-06700	11-26	98501-05020	3-22		
95301-08600	7-16	98501-05022	34-14		
	29-14		34-18		
	31-13	98501-05030	34-15		
95301-08700	26-37	98506-04020	22-21		
95301-08800	21-18	98901-04008	4- 8		
95303-08800	29- 5	98906-06012	7- 4		
95601-06100	34- 4				
	34-11				
95601-14100	19- 4				
95611-10630	1- 8				
95701-06100	23- 8				
	32- 7				
95821-08035	21- 5				
95821-08115	15- 2				
95821-10090	15- 6				
95821-10105	15- 5				
97301-06012	33-23				
97301-06016	16-18				
	18- 9				
97301-06020	16- 4				
	16-23				
	22-29				
97301-06022	34- 5				
97301-06025	5- 8				
	16-15				
97301-08016	19-19				
	19-25				
	24-18				
	27-23				
97301-08020	15-10				
	19-17				
97301-08025	24- 6				
	24-10				
	31- 9				
97301-08045	21-16				
97301-10016	28-25				
97301-10040	21-14				
97321-06020	14-12				

PARTS NAME INDEX

PARTS NAME INDEX

PARTS NAME INDEX

DESCRIPTION	REF. NO.
ABSORBER 1	1-10
ABSORBER 1	1-11
ABSORBER 2	1-12
*	1-13
ABSORBER 3	1-14
ABSORBER 4	12-11
AXLE, drive	12- 2
AXLE, main (11T)	26-40
AXLE, sprocket	25-29
AXLE, wheel	26-42
*	4- 2
BALL	11-20
*	21-10
*	21-13
*	22-20
BAND	22-25
*	33-26
*	33- 2
BAND, battery	16- 7
BAND, flap	16-14
*	26-28
BAND, rim (2.50-18)	25-26
BAND, rim (2.75-19)	29- 6
BAND, switch cord	33-19
*	33-20
*	34-16
BAR, shift fork guide 1	13-14
BAR, shift fork guide 2	13-15
BAR, tension	26-33
BASE, magneto	3- 2
BATTERY ASSY (6N4-2A-2)	33- 1
BEARING (B6004Z)	26-17
BEARING (B6202Z)	26- 4
BEARING (B6204)	12-20
BEARING (B6205)	2-12
BEARING (B6301Z)	25- 2
BEARING (B6304)	12-23
BEARING (B6304C3)	2-11
BEARING, cylindrical	2- 7
*	2-19
*	12-19
*	35-30
*	35-31
BODY ASSY, headlight	31- 8
BODY, cap	18- 5
BODY, float chamber 1	6-10
BOLT	5- 8

DESCRIPTION	REF. NO.
BOLT	10-21
*	13-16
*	13-19
*	14-12
*	15-10
*	16- 4
*	16-15
*	16-18
*	16-23
*	18- 9
*	19-17
*	19-19
*	19-23
*	19-25
*	21-14
*	21-16
*	22-29
*	24- 5
*	24- 6
*	24-10
*	24-18
*	25-18
*	26-14
*	26-21
*	26-34
*	26-35
*	27-14
*	27-18
*	27-23
*	28-16
*	28-25
*	31- 9
*	33-23
*	34- 3
*	34- 5
*	34-10
BOLT 1	22-18
BOLT, cap	22-15
BOLT, flange	15- 2
*	15- 5
*	15- 6
*	21- 5
BOLT, hexagon socket head	22-17
BOLT, set	11-24
BOLT, stud	1- 6
*	1- 8
*	7-13
BOLT, washer based	21- 6

DESCRIPTION	REF. NO.
BOLT, with washer	11-11
BOOT	22-14
*	27-10
BOSS, clutch	11- 5
BRACKET, seat	24- 3
*	24- 4
BRAKE SHOE COMP.	25- 7
*	26-10
BRAKE SHOE PLATE ASSY	26- 8
BREATHER	8-10
BULB (6V-10W)	29- 3
*	29- 9
*	29-12
BULB (6V-17/5.3W)	32- 3
BULB (6V-25/25W)	31- 4
BULB (6V-3W)	30- 3
BUSH	25-10
BUSH 1	19- 2
C.D.I. MAGNETO ASSY	3- 1
C.D.I. UNIT ASSY	33-25
CABLE, brake	27-12
CABLE, clutch	27-16
CABLE, pump	27- 9
CABLE, throttle 1	27- 7
CABLE, throttle 2	27- 8
CAMSHAFT	25-20
*	26-12
CAP	6-35
*	19-21
CAP ASSY	23-21
*	23-23
CAP 1	34-12
CAP, cleaner case 1	5-16
CAP, plunger	6- 3
CARBURETOR ASSY 1	6- 1
CARRIER ASSY	24- 9
CASE, air cleaner 1	5-13
CHAIN (DID428HM-118L)	26-31
CHAIN CASE ASSY	19- 7
CIRCLIP	2-17
*	4-22
*	10- 5
*	10- 9
*	10-14
*	10-19
*	12- 8
*	12-10
*	12-13

PARTS NAME INDEX

DESCRIPTION	REF. NO.
CIRCLIP	14-9
*	25-16
*	26-18
*	35-5
*	35-10
*	35-15
*	35-20
*	35-25
CLAMP	3-10
*	3-13
*	3-17
*	5-7
*	33-21
CLAMP, carrier	24-16
CLAMP, hose	5-10
*	5-12
CLIP	4-5
*	4-13
*	4-24
*	6-31
*	10-3
*	18-11
*	23-20
CLIP, oil seal	22-5
CLIP, Plunger	6-18
CLUTCH ASSY	11-1
CLUTCH, hub	26-16
CLUTCH, meter	25-15
COIL, charge	3-4
*	3-5
COIL, lighting	3-8
COLLAR	2-10
*	11-18
*	12-26
*	25-32
*	26-39
*	26-45
*	28-2
*	30-6
CONNECTING ROD ASSY	35-26
CONNECTOR, cable	27-6
CORD ASSY	3-12
COVER, ball race 2	21-8
COVER, crankcase 1	9-1
COVER, crankcase 2	9-9
COVER, dust	19-27
COVER, Generator	9-4

PARTS NAME INDEX

DESCRIPTION	REF. NO.
COVER, handle lever	27-13
*	27-17
COVER, hub dust	25-28
COVER, kick lever	10-20
COVER, oil Pump	9-15
COVER, Plate	26-24
COVER, Plunger caP	6-34
COVER, shift Pedal	14-11
COVER, side (L.H)	17-1
COVER, side (R.H)	17-4
COVER, single seat	24-2
COVER, sPring	10-8
CRANK 1	2-2
CRANK 2	2-3
CRANKCASE 1	8-1
CRANKCASE 2	8-7
CRANKSHAFT ASSY	2-1
CROWN, handle	21-3
CUP, filter	23-14
CYLINDER 1	1-4
DAMPER	26-7
*	30-4
DAMPER 2	30-5
DAMPER, locating 1	17-6
*	23-4
*	23-6
DAMPER, locating 2	23-5
DUCT	5-14
ELEMENT, air cleaner	5-15
EMBLEM	17-3
*	17-7
EMBLEM 1	23-3
EXHAUST PIPE ASSY 1	7-1
FENDER, front	16-1
FENDER, rear	16-12
FLANGE, sPacer	25-4
*	26-3
FLAP	16-6
*	16-13
FLASHER RELAY ASSY	29-15
FLOAT	6-11
FOOTREST	28-18
FOOTREST 1	28-19
FOOTREST 2	28-20
FORK UNIT ASSY	22-3
FORK UNIT ASSY 2	22-2
FORK, shift 1	13-11
FORK, shift 2	13-12

PARTS NAME INDEX

DESCRIPTION	REF. NO.
FORK, shift 3	13-13
FRAME COMP	15-1
*	15-1
FRONT CARRIER ASSY	24-15
FRONT FLASHER LIGHT ASSY 1	29-1
FRONT FORK ASSY	22-1
FUEL COCK ASSY 1	23-9
FUEL TANK COMP.	23-1
FUSE (6V-10A)	33-7
FUSE HOLDER ASSY	33-6
GASKET	4-7
*	6-30
*	8-13
*	22-16
*	23-15
*	23-18
*	33-16
*	35-36
*	35-42
GASKET KIT	35-32
GASKET, air cleaner	5-19
*	35-40
GASKET, caP	23-22
*	23-24
GASKET, crankcase cover	9-5
*	9-11
*	35-43
*	35-44
GASKET, cylinder	1-5
*	35-34
GASKET, cylinder head 1	1-2
*	35-33
GASKET, drain	13-17
*	35-46
GASKET, exhaust PiPe	7-12
*	35-41
GASKET, float chamber	6-12
*	35-38
GASKET, lens	32-4
GASKET, level gauge	18-4
GASKET, oil Pump cover 1	9-16
*	35-45
GASKET, Plug blind	13-10
GASKET, Pump case	4-16
*	35-37
GASKET, valve seat	5-5
*	35-39
GEAR, drive (26T)	25-9
GEAR, kick (27T)	10-2

PARTS NAME INDEX

DESCRIPTION	REF. NO.
GEAR, kick idle (26T)	10-12
GEAR, meter (9T)	25-11
GEAR, Primary drive (19T)	11-14
GEAR, Pump drive (30T)	4-20
GEAR, 1st wheel (35T)	12-12
GEAR, 2nd Pinion (15T)	12-2
GEAR, 2nd wheel (30T)	12-15
GEAR, 3rd Pinion (19T)	12-4
GEAR, 3rd wheel (26T)	12-16
GEAR, 4th Pinion (24T)	12-5
GEAR, 4th wheel (21T)	12-17
GEAR, 5th Pinion (27T)	12-6
GEAR, 5th wheel (18T)	12-18
GEAR, 5th wheel (18T)	23-2
GRAPHIC SET	27-5
GRIP (L.H)	27-2
GRIP (R.H)	3-15
GROMMET	9-2
*	17-2
*	17-5
*	26-9
*	19-22
GUARD, chain	27-22
GUARD, lever	16-21
GUARD, mud	16-21
GUIDE, spring	10-7
HANDLEBAR	27-1
HEAD, cylinder 1	1-1
HEADLIGHT UNIT ASSY	31-1
HOLDER	6-33
*	8-8
HOLDER, cable	22-24
HOLDER, cable 1	22-28
HOLDER, handle upper	21-4
HOLDER, kick gear	10-4
HOLDER, lever 1	34-1
HOLDER, lever 2	34-8
HOLDER, oil pipe	4-23
HOOK, spring	11-28
HORN	33-22
HOSE	4-4
*	8-11
*	18-6
*	23-19
*	33-3
HOUSING, Push screw	11-30
HUB, front	25-1
HUB, rear	26-1

PARTS NAME INDEX

DESCRIPTION	REF. NO.
IGNITION COIL ASSY	33-8
INNER TUBE COMP.1	22-7
JET, main (#135)	6-21
JET, main (#145)	6-21
JET, main (#155)	6-21
JET, Pilot (#27.5)	6-2
JOINT, air cleaner 1	5-11
JOINT, carburetor	5-6
JOINT, chain	26-32
JOINT, exhaust 1	7-19
KEY, woodruff	2-8
KICK AXLE ASSY	10-1
KICK CRANK ASSY	10-15
LENS ASSY	31-3
LENS, flasher	29-2
*	29-8
*	29-11
LENS, level gauge	18-2
LENS, taillight	32-5
LEVER HOLDER ASSY 2	34-7
LEVER 1	34-2
LEVER 2	34-9
LEVER, camshaft	26-13
LEVER, camshaft 1	25-17
LEVER, cock	23-10
LEVER, kick	10-16
LEVER, Push	11-25
MAIN AXLE COMP.	12-1
MAIN SWITCH ASSY	33-12
METAL, worm shaft outer	4-19
MIRROR ASSY (L.H)	27-21
*	27-21
MIRROR ASSY (R.H)	27-20
*	27-20
NEEDLE	6-8
NEEDLE VALVE ASSY	6-5
NET, filter 2	23-16
NEUTRAL SWITCH ASSY	33-15
NOZZLE	4-6
NOZZLE, main	6-9
NUT	1-7
*	1-9
*	3-20
*	4-12
*	7-15
*	7-16
*	11-12
*	11-15
*	11-26
*	12-27

PARTS NAME INDEX

DESCRIPTION	REF. NO.
NUT	14-5
*	16-9
*	19-16
*	21-7
*	23-17
*	25-19
*	26-15
*	26-23
*	26-37
*	26-41
*	27-11
*	27-15
*	27-19
*	29-14
*	30-8
*	31-13
*	6-22
NUT, cable adjusting	25-30
NUT, castle	26-43
*	20-4
NUT, crown	21-18
*	29-5
*	23-8
NUT, flange	32-7
*	15-3
NUT, self-locking	15-7
*	28-17
NUT, u	19-4
*	34-4
*	34-11
NUT, wing	28-9
O-RING	2-9
*	6-19
*	11-3
*	23-13
*	25-34
*	26-6
*	35-35
OIL PUMP ASSY	4-1
OIL SEAL	2-13
*	2-14
*	4-18
*	10-11
*	11-22
*	11-29
*	12-24
*	14-7
*	22-4

PARTS NAME INDEX

PARTS NAME INDEX

PARTS NAME INDEX

DESCRIPTION	REF. NO.
OIL SEAL	25- 5
*	25-12
*	25-21
*	26- 5
*	26-19
*	35-48
*	35-49
*	35-50
*	35-51
*	35-52
*	35-53
*	35-54
*	35-55
OIL SEAL KIT	35-47
OIL TANK ASSY	18- 1
PEDAL, brake	28- 1
PEDAL, shift	14-10
PIN	28- 8
PIN, clevis	28- 5
*	28-22
PIN, cotter	6-32
*	25-31
*	26-38
*	26-44
*	28- 6
*	28-12
*	28-24
PIN, crank 1	2- 5
*	35-28
PIN, dowel	4-21
*	8- 5
*	8- 6
*	9- 3
*	9-10
*	13- 2
PIN, float	6- 6
PIN, Piston	2-16
*	35- 4
*	35- 9
*	35-14
*	35-19
*	35-24
PIN, spring	13- 3
PIPE	6-15
*	6-37
PIPE, oil tank breather	18- 7
PIPE, outlet	7- 9
PISTON (STD)	2-15
*	2-15

DESCRIPTION	REF. NO.
PISTON (STD)	35- 2
*	2-15
PISTON (1ST O/S 0.25MM)	35- 7
*	2-15
PISTON (2ND O/S 0.50MM)	35-12
*	2-15
PISTON (3RD O/S 0.75MM)	35-17
*	2-15
PISTON (4TH O/S 1.00MM)	35-22
*	35- 1
PISTON ASSY (STD)	35- 6
PISTON ASSY (1ST O/S)	35-11
PISTON ASSY (2ND O/S)	35-16
PISTON ASSY (3RD O/S)	35-21
PISTON ASSY (4TH O/S)	2-18
PISTON RING SET (STD)	35- 3
*	2-18
PISTON RING SET (1ST O/S)	35- 8
*	2-18
PISTON RING SET (2ND O/S)	35-13
*	2-18
PISTON RING SET (3RD O/S)	35-18
*	2-18
PISTON RING SET (4TH O/S)	35-23
*	4- 9
PLATE, adjusting	25- 6
PLATE, brake shoe	11- 7
PLATE, clutch 1	12-21
PLATE, cover	11- 6
PLATE, friction	25-22
PLATE, indicator	11- 9
PLATE, Pressure 1	13- 4
PLATE, side 1	11- 4
PLATE, thrust 1	11-17
PLATE, thrust 2	12-29
PLUG	33-11
PLUG CAP ASSY	33-11
*	13- 8
PLUG, blind	22-26
PLUG, drain	9-14
PLUG, oil level	6-20
PLUG, screw	1- 3
PLUG, spark	8-12
PLUG, straight screw	6- 7
PLUNGER, starter	13- 7
POINT, neutral	11- 2
PRIMARY DRIVEN GEAR COMP.	7- 3
PROTECTOR, muffler 2	7- 2
PROTECTOR, muffler 1	7- 2

DESCRIPTION	REF. NO.
PROTECTOR, Pedal	15- 9
PULLER, chain 1	26-46
PULLER, chain 2	26-47
RACE, ball 1	21- 1
*	21- 9
RACE, ball 2	21-11
*	21-12
REAR ARM COMP.	19- 1
REAR FLASHER LIGHT ASSY	29-10
REAR FLASHER LIGHT ASSY 1	29- 7
RECTIFIER ASSY	3-21
*	3-21
REED VALVE ASSY	5- 1
REED, valve	5- 2
REFLECTOR, level gauge	18- 3
RIM (1.60-19)	25-27
RIM (1.85-18)	26-29
RIM, headlight	31- 2
RING, cushion	11- 8
RING, leaf	27- 4
RING, piston	22-12
RING, stop	25-33
ROD, brake	28- 3
ROD, connecting	2- 4
*	35-27
ROD, Push 1	11-19
ROD, Push 2	11-21
ROTOR ASSY	3- 3
SCREW	14- 4
SCREW 1	3-11
*	3-14
SCREW 2	3- 9
SCREW, air adjusting	6-24
SCREW, bind	4- 8
*	7- 4
SCREW, cable adjusting	6-36
SCREW, flat head	3-16
SCREW, lens fitting	32- 6
SCREW, lever fitting	23-12
SCREW, Pan head	3- 7
*	3-22
*	4-17
*	5-17
*	5-20
*	5-22
*	6-16
*	7-10
*	8- 2
*	8- 3

PARTS NAME INDEX

DESCRIPTION	REF. NO.
SCREW, Pan head	8- 4
*	8- 9
*	9- 6
*	9- 7
*	9- 8
*	9-12
*	9-13
*	9-17
*	11-32
*	12-22
*	12-30
*	13- 5
*	13- 9
*	16- 8
*	19- 8
*	19-10
*	19-12
*	19-30
*	19-32
*	22-21
*	31- 7
*	33- 4
*	33- 9
*	33-13
*	33-28
*	34-14
*	34-15
*	34-18
SCREW, Pan head with washer	5- 4
SCREW, Push	11-23
SCREW, throttle	6-14
SEAL, dust	22-27
SEAL, Guard	19- 6
SEAL, steering	21- 2
SEAT, spring lower	22-11
SEAT, spring upper	22-23
SHAFT, Pivot	19- 3
SHAFT, worm	4-14
SHIFT CAM ASSY	13- 1
SHIFT SHAFT ASSY	14- 1
SHIM (0.3T)	4-10
SHIM (0.5T)	4-10
SHIM (1.0T)	4-10
SHIM 1 (1.0T)	12-14
SHOCK ABSORBER ASSY, rear	20- 1
SILENCER, exhaust	7- 8
SINGLE SEAT ASSY	24- 1
SOCKET	31- 5

PARTS NAME INDEX

DESCRIPTION	REF. NO.
SOCKET ASSY	30- 2
SPACER	3- 6
*	25- 3
*	26- 2
SPACER, bead	26-30
SPEEDOMETER ASSY	30- 1
SPEEDOMETER CABLE ASSY	30- 9
SPOKE SET, front	25-23
SPOKE SET, rear	26-25
SPRING	22- 9
*	23-11
*	24-14
SPRING, air adjusting	6-23
SPRING, check ball	4- 3
SPRING, compression	10-17
*	11-10
*	28- 7
SPRING, front carrier	24-17
SPRING, front fork	22-22
SPRING, Plunger	6-28
SPRING, rebound	22-10
SPRING, reflector	31- 6
SPRING, tension	11-27
*	13-20
*	14- 2
*	25- 8
*	26-11
*	28-15
SPRING, throttle stop	6-13
SPRING, throttle valve	6-27
SPRING, torsion	10- 6
*	14- 3
*	28-10
*	28-21
SPROCKET, drive (14T)	12-25
SPROCKET, drive (15T)	12-25
SPROCKET, drive (16T)	12-25
SPROCKET, driven (47T)	26-20
STAND, side	28-13
*	28-14
STAY, chain case 2	19-29
STAY, dust cover 1	19-28
STAY, dust cover 3	19-31
STAY, flasher 1	29- 4
STOP SWITCH ASSY	33-17
STOPPER	10-10
STOPPER LEVER ASSY	13-18
STOPPER, cable	6-26

PARTS NAME INDEX

DESCRIPTION	REF. NO.
STOPPER, reed valve	5- 3
SWITCH, handle 1	34-17
SWITCH, handle 4	34-13
TAILLIGHT BASE ASSY	32- 2
TAILLIGHT UNIT ASSY	32- 1
TAPER, spindle	22-13
TIRE (3.00-19)	25-24
TIRE (4.10-18)	26-26
TOOL BDX COMP.	24-13
TOOL KIT	24-20
TOP, mixing chamber	6-29
TUBE (2.75-19)	25-25
TUBE (3.50-18)	26-27
TUBE, throttle Guide	27- 3
UNDER BRACKET COMP.	22- 8
VALVE, throttle 1	6-25
VOLTAGE REGULATOR ASSY	33-27
WASHER	2- 6
*	7- 7
*	10-13
*	16- 3
*	26-22
*	31-12
*	33-30
*	35-29
WASHER, conical spring	11-16
WASHER, kick lever	10-18
WASHER, lock	11-13
*	12-28
*	14- 6
WASHER, needle valve	6- 4
WASHER, Plain	19-14
*	28- 4
WASHER, Plate	3-18
*	3-23
*	4-15
*	5- 9
*	5-18
*	5-21
*	5-23
*	7- 5
*	7- 6
*	7-18
*	11-31
*	12- 7
*	12- 9
*	14- 8
*	16- 2

PARTS NAME INDEX

PARTS NAME INDEX

DESCRIPTION	REF. NO.
WASHER, Plate	16-11
*	16-17
*	16-20
*	16-22
*	18- 8
*	19- 5
*	19-13
*	20- 2
*	20- 3
*	22-31
*	23- 7
*	24- 8
*	24-12
*	25-13
*	25-14
*	28-23
*	31-11
WASHER, Plate (1.5T)	28-11
WASHER, sPecial	22- 6
*	30- 7
WASHER, sPring	3-19
*	4-11
*	6-17
*	7-11
*	7-14
*	7-17
*	11-33
*	13- 6
*	15- 4
*	15- 8
*	15-11
*	16- 5
*	16-10
*	16-16
*	16-19
*	16-24
*	18-10
*	19- 9
*	19-11
*	19-15
*	19-18
*	19-20
*	19-24
*	19-26
*	19-33
*	21-15
*	21-17
*	22-19

DESCRIPTION	REF. NO.
WASHER, sPring	22-30
*	24- 7
*	24-11
*	24-19
*	26-36
*	27-24
*	28-26
*	29-13
*	31-10
*	33- 5
*	33-10
*	33-14
*	33-24
*	33-29
*	34- 6
WIRE HARNESS ASSY	33-18



COPY RIGHT: ALL RIGHTS RESERVED
NO PART OF THIS PUBLICATION MAY BE
REPRODUCED WITHOUT PERMISSION.

www.legends-yamaha-enduros.com



YAMAHA

YAMAHA MOTOR CO., LTD.
2500 SHINGAI IWATA-SHI SHIZUOKA-KEN JAPAN

PRINTED IN JAPAN

First edition Sep., 1980

T.G