

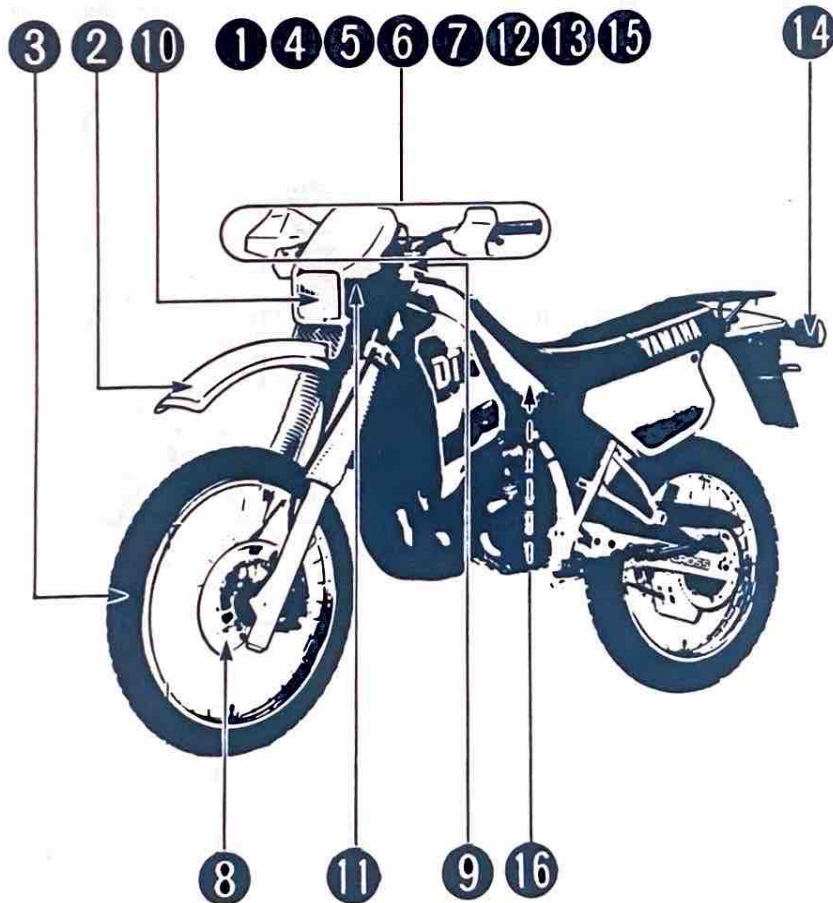















DT125R

ASSEMBLY MANUAL
NOTICE D'ASSEMBLAGE
MONTAGEANLEITUNG
MANUAL DE ENSAMBLE



SYMBOLS USED IN ASSEMBLY MANUALS

In order to simplify descriptions in assembly manuals, the following symbols are used:















-  : Coat with grease
-  : Tighten to 10 Nm (10 Nm = 1.0 m·kg = 7.2 ft·lb)
-  : Make a 5 mm-dia. hole
-  : Frontward (of the vehicle)
-  : Provide a 1 mm clearance (1 mm = 0.04 in)
-  : Provide a 50° angle
-  : Provide a clearance
-  : Select proper parts because they differ in type depending on the destination
-  : Install so that the arrow mark faces upward
-  : Made of rubber or plastics
-  : Apply SAE 10W30 motor oil
-  : Clutch cable
-  : Throttle cable
-  : Brake cable
-  : Breather pipe



- a** : Ref. No. (indicating the order of operations)
- b** : Size of part (mm) or part No.
- c** : Quantity of parts per vehicle
- d** : Place where parts are held (Stored)
- V** : Stored in vinyl bag
- C** : Stored in small carton box
- S** : Fixed inside the crate
- *** : Temporarily installed or secured

SYMBOLE DIE IN DER MONTAGEANLEITUNG VERWENDET WERDEN















Um die Beschreibungen in den Montageanleitungen zu vereinfachen, werden die folgenden Symbole verwendet:

-  : Mit Fett schmieren
-  : Mit 10 Nm festziehen (10 Nm = 1,0 m·kg = 7,2 ft·lb)
-  : Ein Loch mit 5 mm Durchmesser bohren
-  : Vorderseite (des Fahrzeuges)
-  : Einen Abstand von 1 mm vorsehen (1 mm = 0,04 in)
-  : Einen Winkel von 50° vorsehen
-  : Ein Spiel vorsehen
-  : Das richtige Teil auswählen, da sich die Teile in Abhängigkeit vom Bestimmungsland unterscheiden
-  : So einbauen, da die Pfeilmarkierung nach oben weist
-  : Hergestellt aus Gummi oder Kunststoff
-  : Motoröl SAE 10W30 schmieren
-  : Kupplungsseil
-  : Gasseil
-  : Bremsseil
-  : Belüftungsrohr

- a** : Referenz-Nr. (bezeichnet Reihenfolge oder Vorgänge)
- b** : Größe des Teiles (mm) oder Teile-Nr.
- c** : Stückzahl dieses Teiles pro Fahrzeug
- d** : Stauposition des Teiles
- V** : Aufbewahrt in Plastiksack
- C** : Aufbewahrt in kleinem Karton (Schachtel)
- S** : In der Kiste befestigt
- *** : Provisorisch eingebaut oder befestigt

SYMBOLES EMPLOYES DANS LES NOTICES D'ASSEMBLAGE

Afin de simplifier les descriptions données dans les notices d'assemblage, les symboles suivants sont employés:



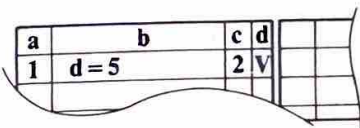











-  : Enduire de graisse
-  : Serrer à 10 Nm (10 Nm = 1.0 m·kg → 7,2 ft·lb)
-  : Percer un trou de 5 mm de diamètre
-  : Avant (du véhicule)
-  : Donner un espace de 1 mm (1 mm = 0,04 in)
-  : Donner un angle de 50°
-  : Donner un espace
-  : Sélectionner les pièces correctes; les types sont différents suivant la destination
-  : Monter de manière telle que la flèche soit orientée vers le haut
-  : En caoutchouc ou plastique
-  : Légèrement huile moteur SAE 10W30
-  : Câble d'embrayage
-  : Câble d'accélération
-  : Câble de frein
-  : Tube de reniflard



- a** : No. de réf. (indiquant l'ordre des opérations)
- b** : Taille de pièce (mm) ou No. pièces
- c** : Nombre de pièces par véhicule
- d** : Endroit où les pièces sont situées (rangées)
- V** : Rangées dans un sachet en vinyle
- C** : Rangées dans une petite boîte de carton
- S** : Fixé dans la caisse
- *** : Temporairement monté ou fixé

SIMBOLOS EMPLEADOS EN LOS MANUALES DE MONTAJE

A fin de simplificar las descripciones de los manuales de montaje se emplean los símbolos siguientes:

-  : Revestir con grasa
-  : Apretar a 10 Nm (10 Nm = 1,0 m·kg = 7,2 ft·lb)
-  : Hacer un orificio de 5 mm de diámetro
-  : Parte delantera (del vehículo)
-  : Dejar una distancia de 1 mm (1 mm = 0,04 in)
-  : Dejar un ángulo de 50°
-  : Dejar una distancia
-  : Seleccionar las piezas apropiadas porque difieren en tipo según la destinación
-  : Instalar de forma que la flecha apunte hacia arriba
-  : Hecho de goma o plástico
-  : Aplique aceite de motor SAE 10W30
-  : Cable del embrague
-  : Cable del acelerador
-  : Cable del freno
-  : Caño respiradero

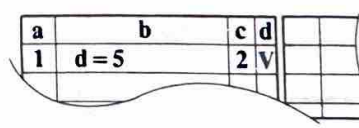

- a** : No. de ref. (indica el orden de las operaciones)
- b** : Tamaño de la pieza (mm) o No. de la pieza
- c** : Cantidad de piezas por vehículo
- d** : Lugar de almacenamiento de las piezas
- V** : Almacenamiento en bolsa de vinilo
- C** : Almacenamiento en caja de cartón pequeña
- S** : Fijo dentro del cajón
- *** : Instalado o asegurado momentáneamente

SETUP PROCEDURE
PROCEDURE DE MONTAJE

MONTAGEVORGANG
PROCEDIMIENTO DE INSTALACION

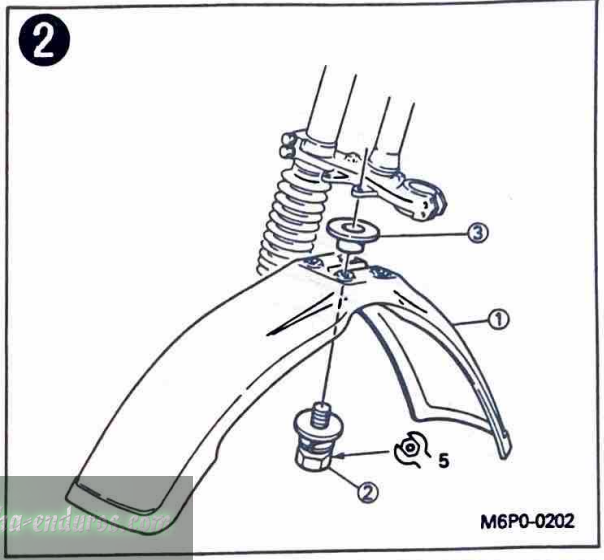
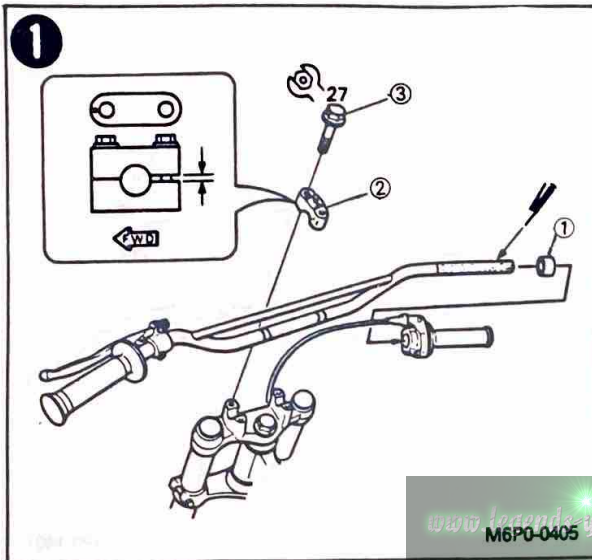

1		1	S
2		2	C
3	91026-08040	4	C

1		1	S
2	90119-06097	4	C
3	90387-062V8	4	C

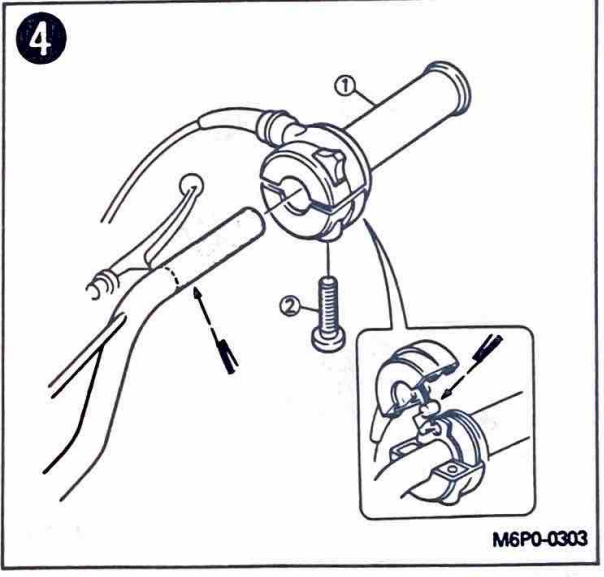
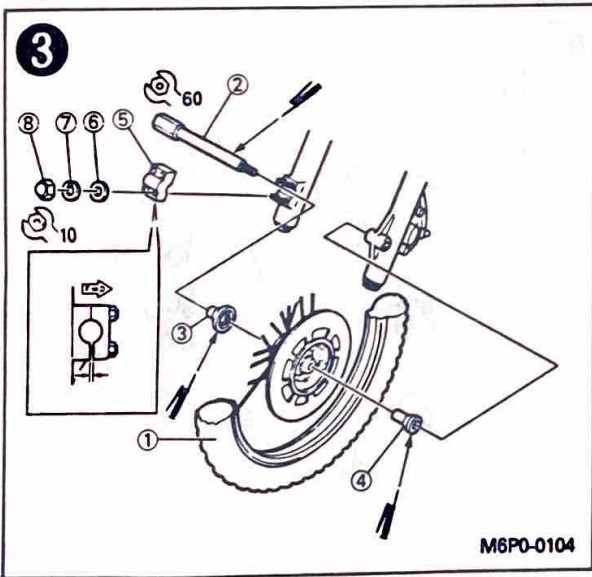

1		1	S
2	d = 14	1	*
3		1	C
4		1	C
5		1	*
6	d = 6	4	*
7	d = 6	4	*
8	d = 6	4	*

1		1	S
2	98506-05020	2	C

SETUP PROCEDURE
PROCEDURE DE MONTAGE

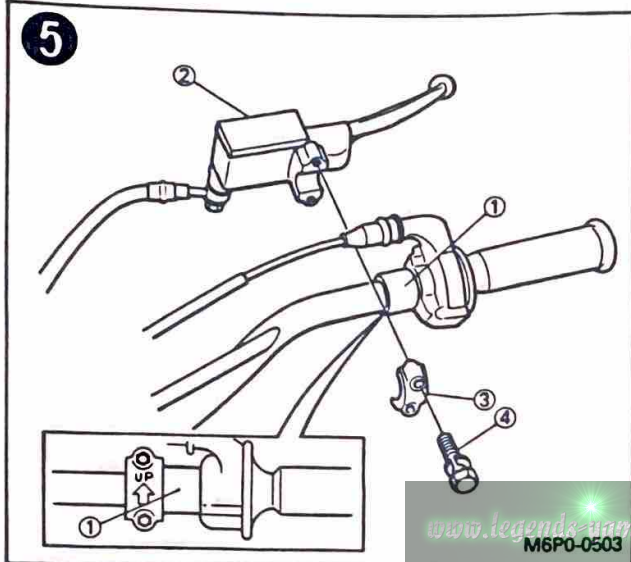

1		1	S
2		1	S
3		1	C
4	d = 6	2	C

MONTAGEVORGANG
PROCEDIMIENTO DE INSTALACION

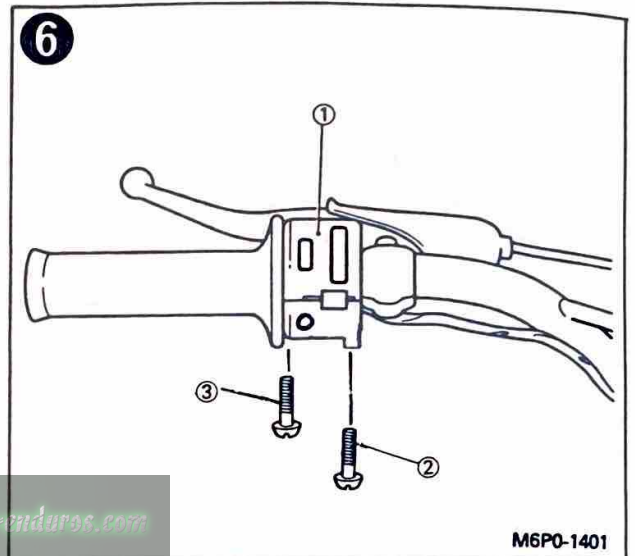

1		1	S
2	d = 5, l = 35	1	C
3	d = 5, l = 30	1	C

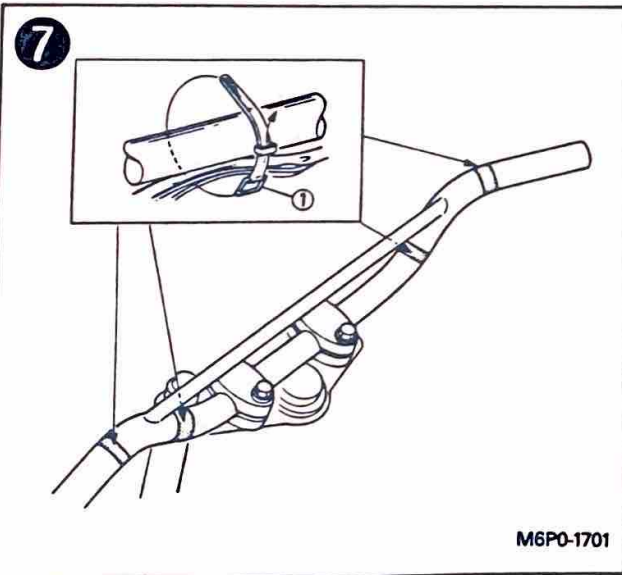

1		4	C

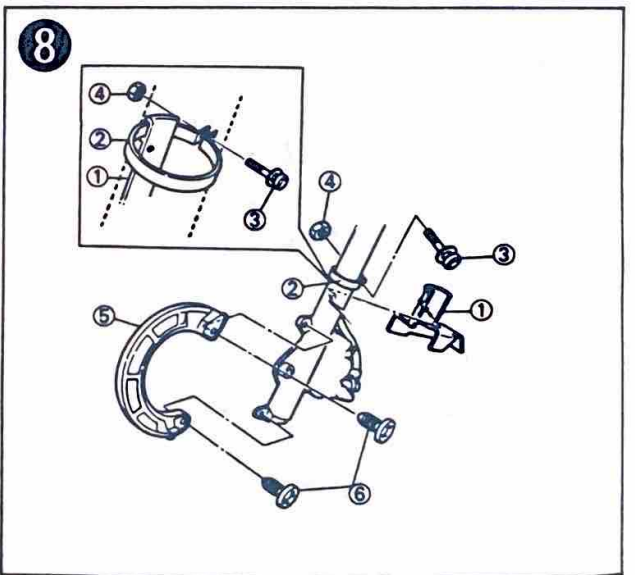

1		1	C
2		1	C
3	98501-05016	1	C
4	95303-05600	1	C
5		1	C
6	90149-06194	2	C

SETUP PROCEDURE
PROCEDURE DE MONTAGE

MONTAGEVORGANG
PROCEDIMIENTO DE INSTALACION

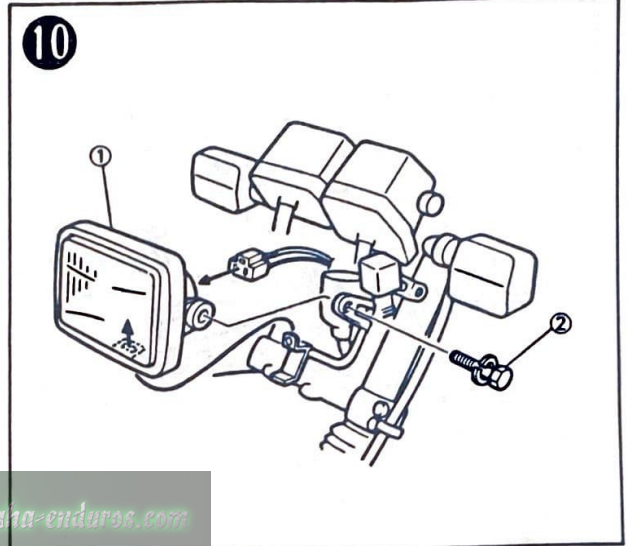
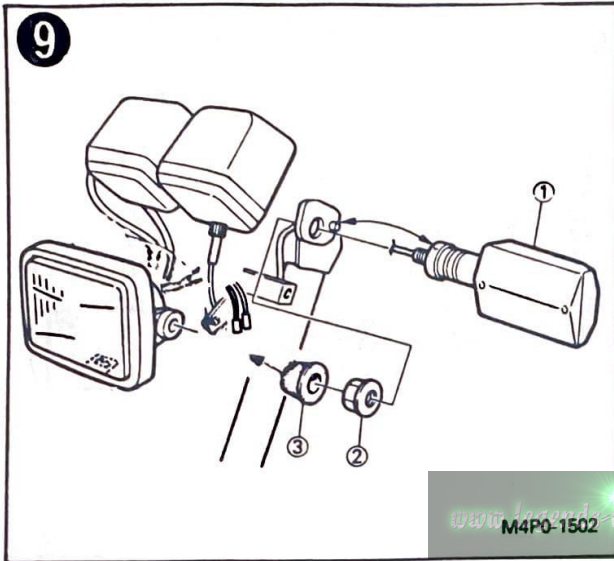

1		2	C		
2	95302-12700	2	C		
3		2	C		

1		1	*		
2	d = 6	2	*		

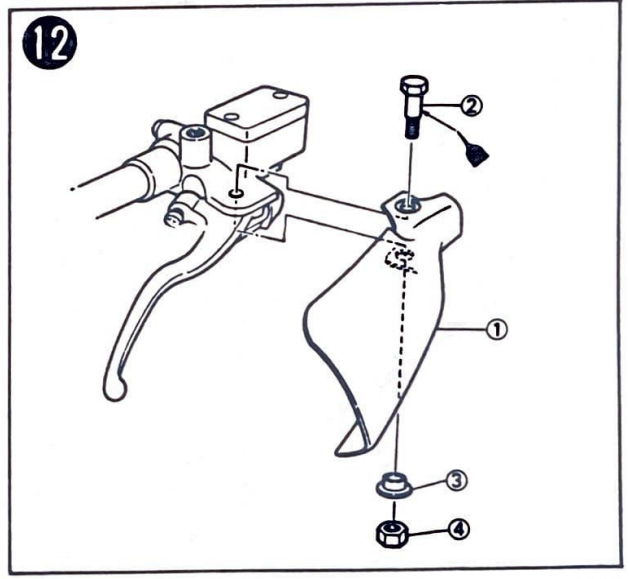
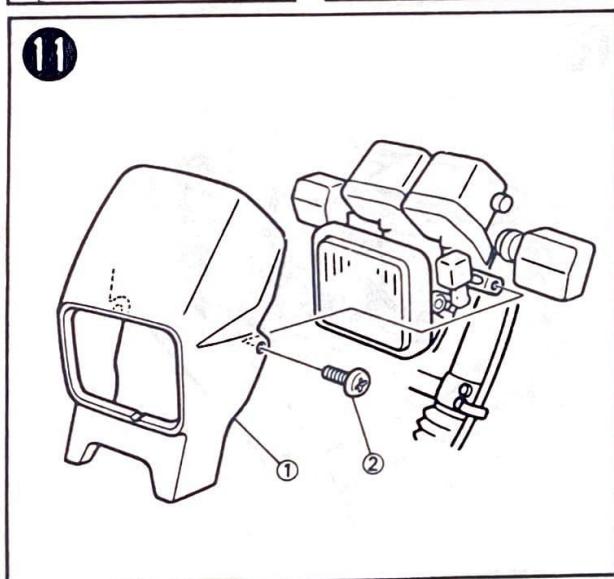

1		1	S		
2	98903-06010	2	C		

1		1	C		
2		1	*		
3		1	C		
4		1	*		

SETUP PROCEDURE
PROCEDURE DE MONTAJE

MONTAGEVORGANG
PROCEDIMIENTO DE INSTALACION

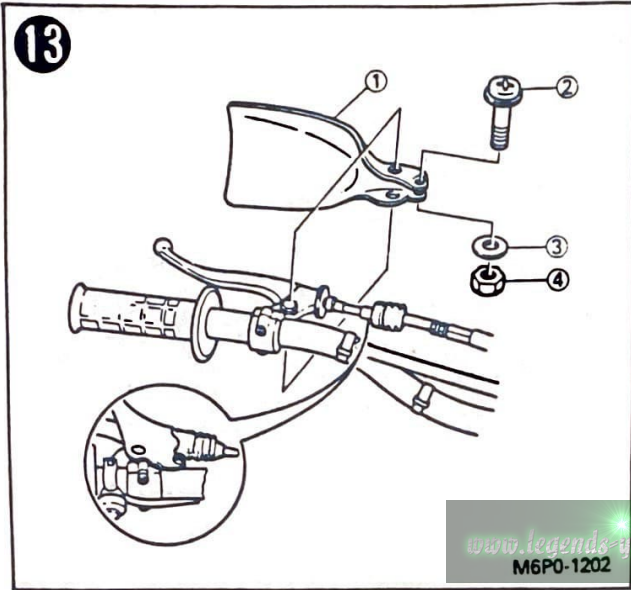

www.legends-yamaha-enduros.com
M6P0-1202

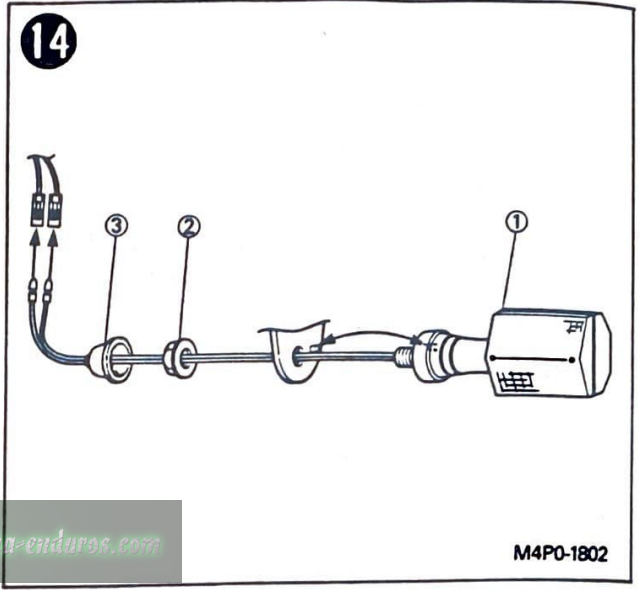

M4P0-1802

1		1	C
2		1	*
3		1	*
4		1	*

1		2	C
2	95302-12700	2	C
3		2	C

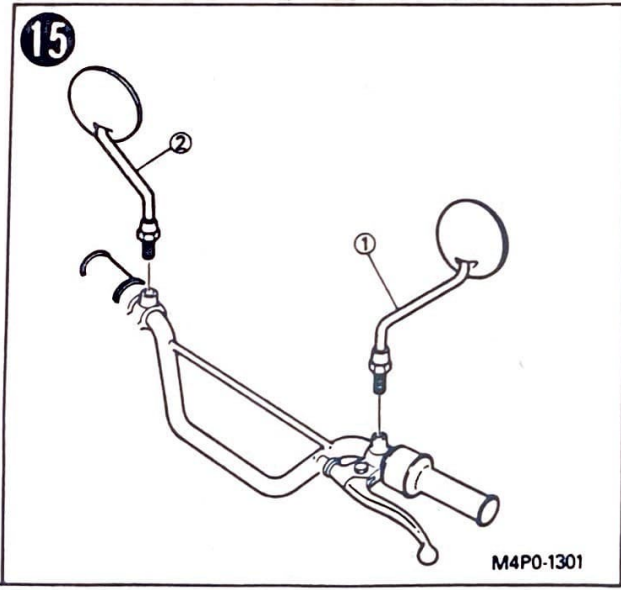

M4P0-1301

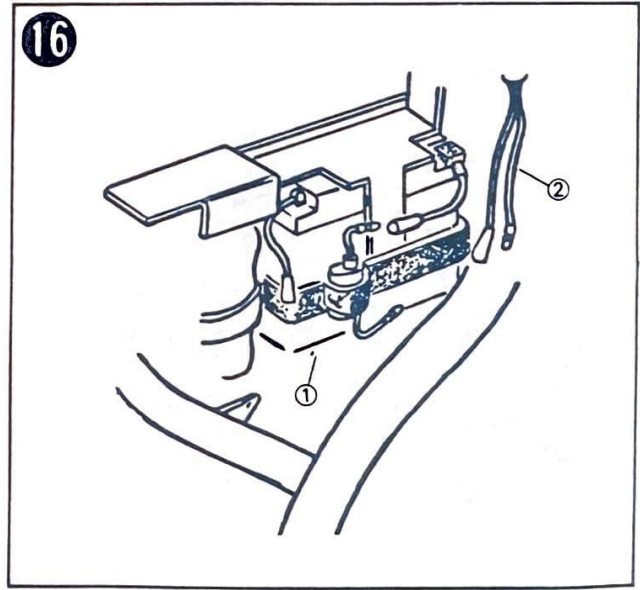

1		1	C
2		1	C

1		1	*
2		1	*

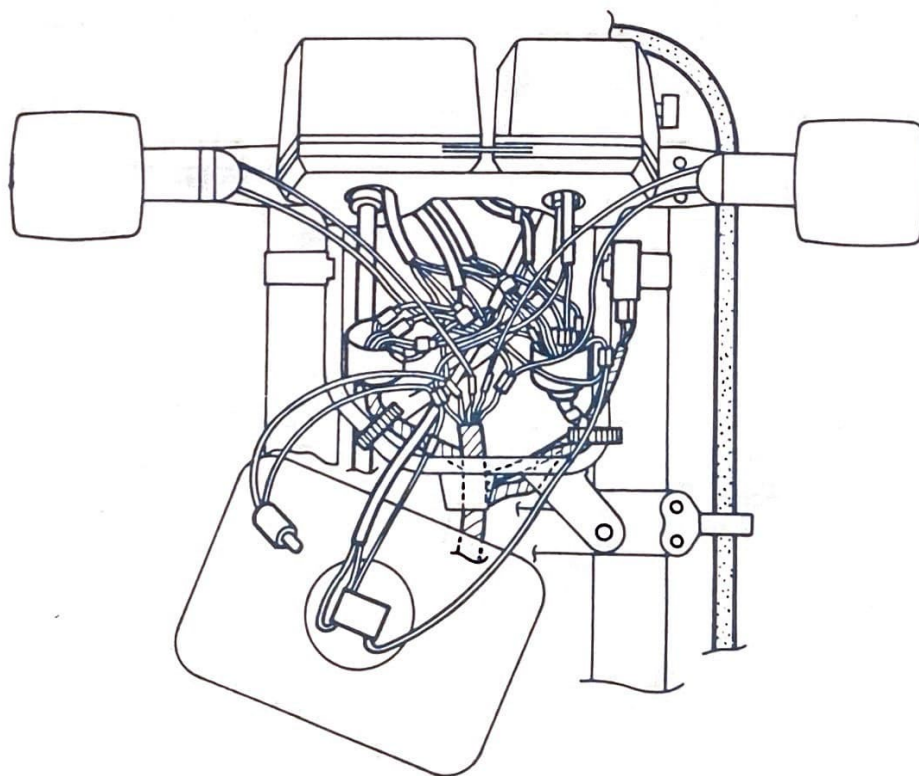
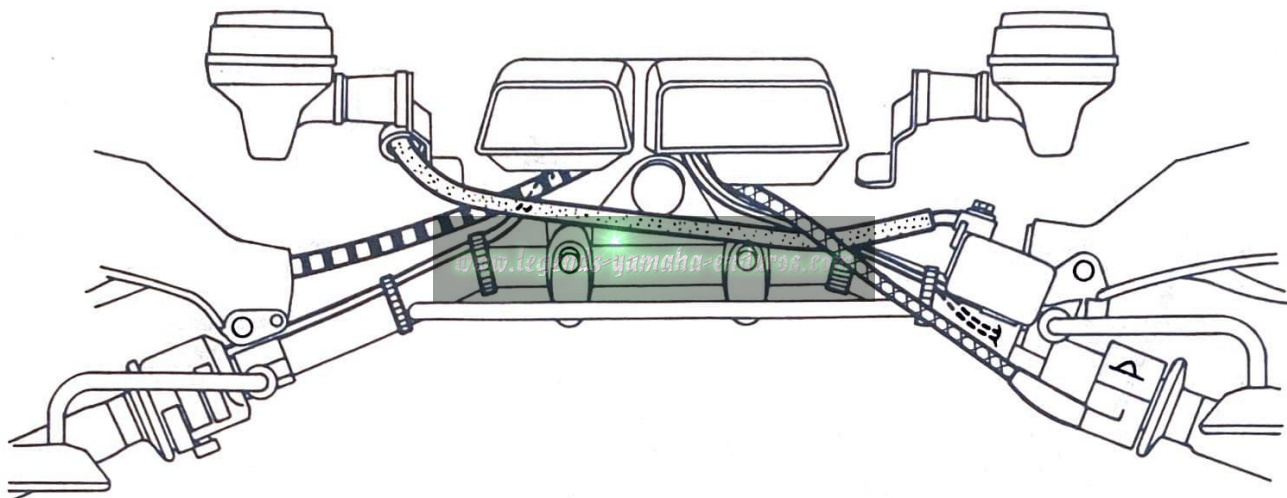

CABLE ROUTING
CHEMINEMENT DES CABLES

KABELFÜHRUNGSÜBERSICHT
INSTALACION DE LOS CABLES

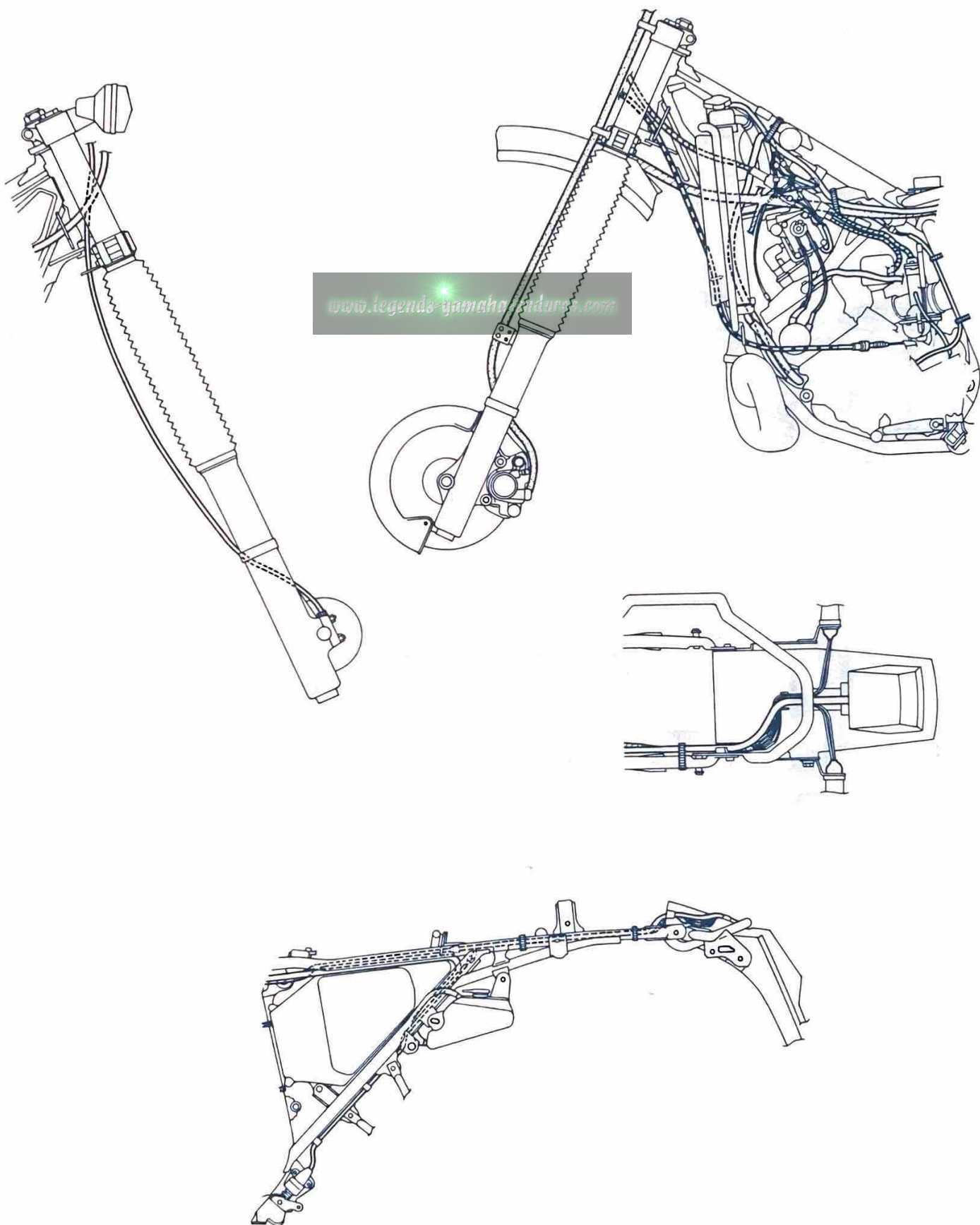

ADJUSTMENTS AND PREDELIVERY SERVICE
REGLAJES ET CONTROLES AVANT LIVRAISON

EINSTELLUNG UND WARTUNG VOR DER AUSLIEFERUNG
SERVICIO DE AJUSTE Y PREENTREGA

 <p>Drain screw Vis de vidange Abläßschraube Tornillo de drenaje</p>	<p>Regular gasoline Essence normale Normalbenzin Regular</p>	 <p>12V4AH</p>
---	---	---

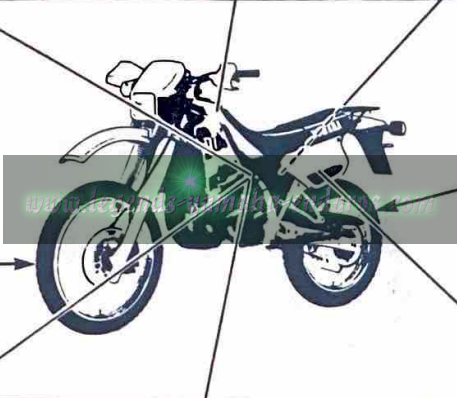

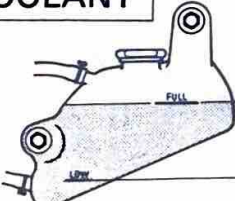
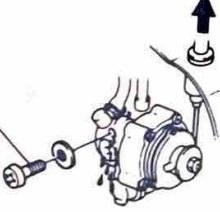
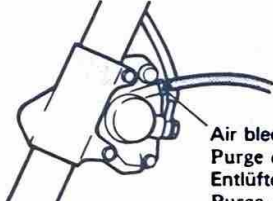

130 kPa
(1.3 kg/cm², 18 psi)

150 kPa
(1.5 kg/cm², 22 psi)

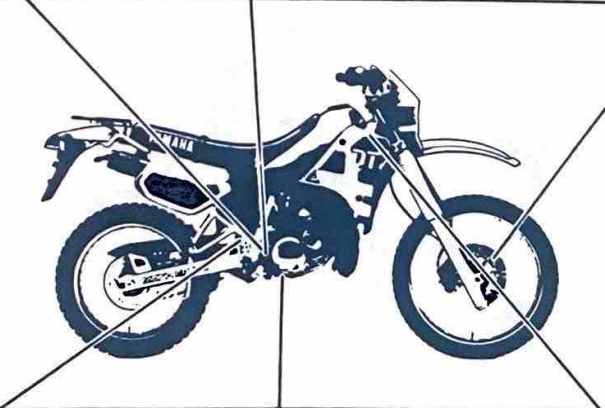
 <p>Throttle stop screw Vis de butée des gaz Gaszuganschlagschraube Tornillo de parada de obturación</p>	<p>Standard idle speed: 1.300 r/min Régime de ralenti nominal: 1.300 tr/min Leerlaufdrehzahl: 1.300 U/min Velocidad normal en vacío: 1.300 r/min</p>	<p>COOLANT</p>  <p>UPPER LOWER</p>
<p>Air bleeding Purge de l'air Entlüften Purga de aire</p> 	<p>SAE 20W40 SE motor oil Huile moteur SAE 20W40 SE SAE 20W40 SE Motoröl Aceite de motor SAE 20W40 SE</p>	 <p>Air bleeding Purge d'air Entlüften Purga de aire</p>

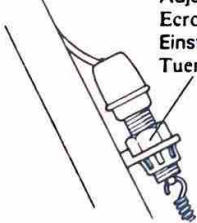

 <p>Adjusting nut Ecroi de réglage Einstellmutter Tuerca de regulación</p>	 <p>15</p>	<p>Yamaha oil 2T Huile Yamaha 2T Yamaha öl 2T Aceite de Yamaha 2T</p>
---	---	--

**ADJUSTMENTS AND PREDELIVERY
SERVICE
REGLAGES ET CONTROLES AVANT
LIVRAISON**

**EINSTELLUNG UND WARTUNG VOR
DER AUSLIEFERUNG
SERVICIO DE AJUSTE Y PREENTREGA**

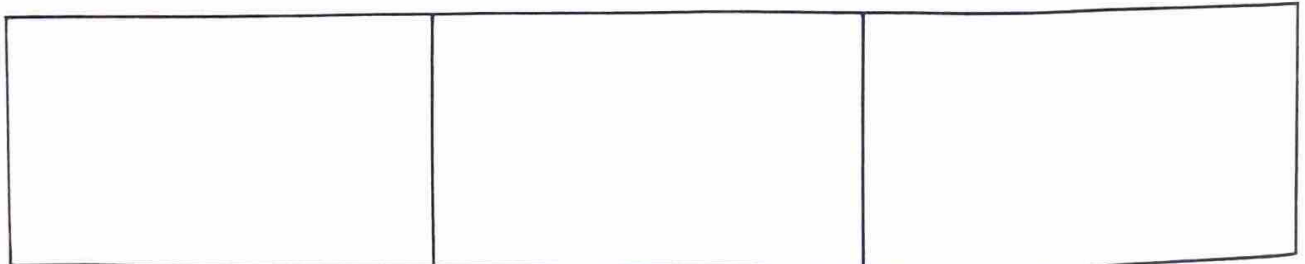
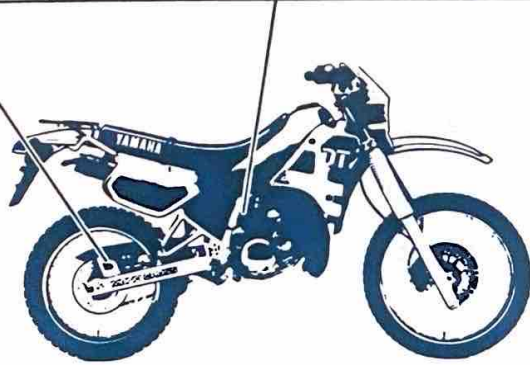
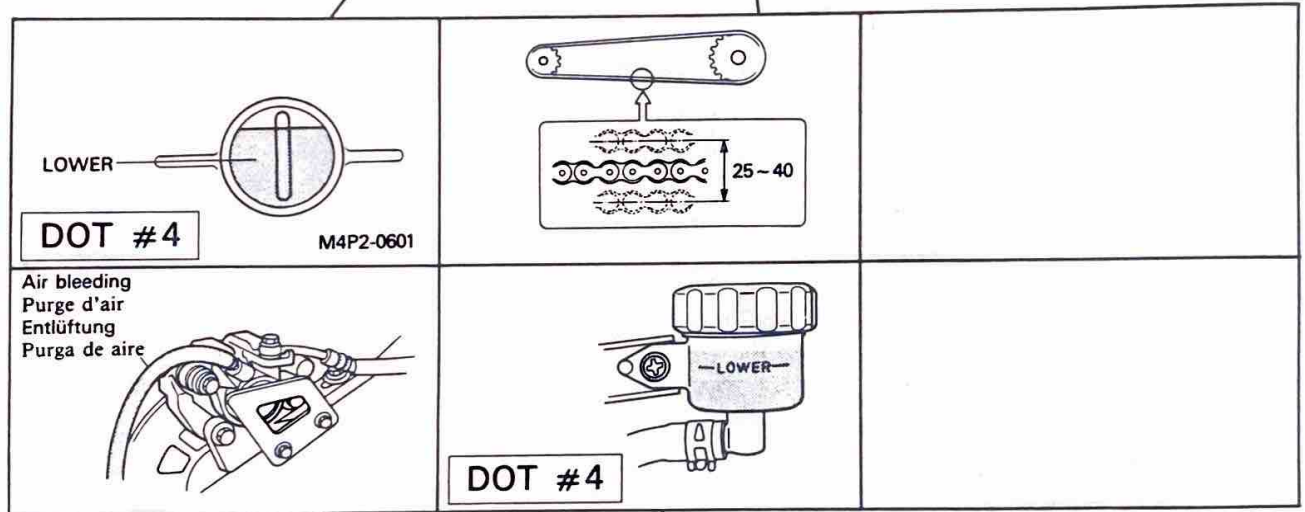
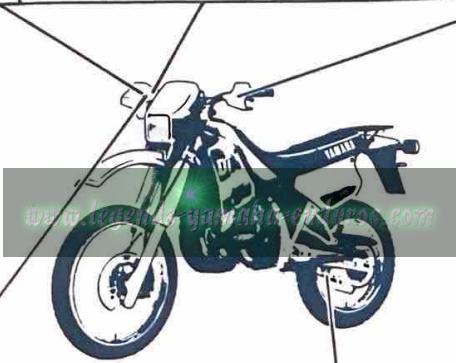
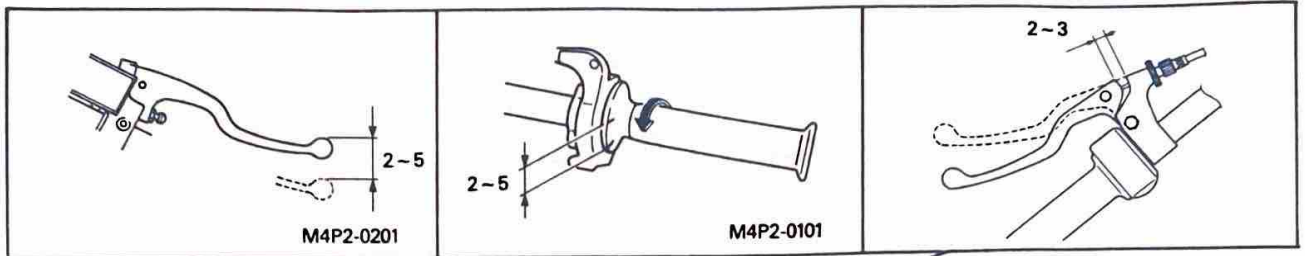

www.legends-yamaha-enduros.com