



YAMAHA MOTOR CO., LTD. AD & PR DIVISION
 2500 Shingai, Iwata-shi, Shizuoka-kan, Japan Tel: 05383 (2) 1111
 Telex: Iwata 4263-751 Yamaha J Cable: Yamaha Motor Iwata

INSIDE PAGES

Pages 2 to 5 are devoted to introducing the technical features of the '84 European motorcycle range, and pages 6 and 7 outline the '84 outboard range.

Break free! *A hot-going new Yamaha breed*



The 1984 European model line-up of motorcycles

'83 "Salon de Paris" Motorcycle Show

The 1984 European model line-up of motorcycles was introduced during the Salon de Paris Motorcycle Show in France held from Oct. 1 to Oct. 9. Designed and built for sheer excitement and true quality that every enthusiast had long craved for, the new line-up came as a big sensation, proving Yamaha's great potential in all the fields of motorcycling. It was truly a hot-going new Yamaha breed including the brand-new superbike FJ1100 and the real GP racer replica RD500LC which have set new high standards in both performance and quality, thus striking every visitor with an impression—"The Thrill Is Back".



Hakan Carlqvist and new YZ machines

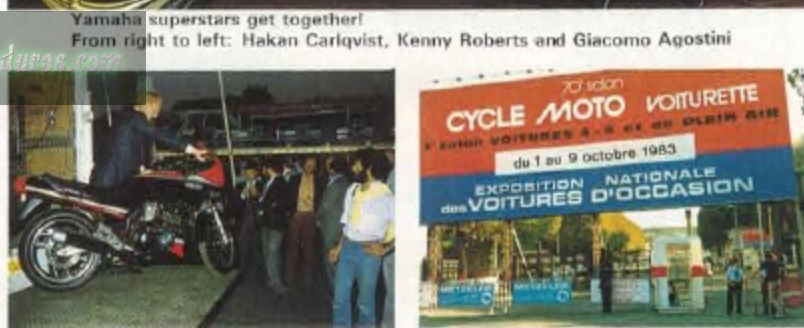

Sonauto Yamaha director J.C. Olivier and new XJ600



Entrance to the show

The 1984 Outboard Line-up

Chicago (IMTEC) Show

The 1984 Yamaha outboard line-up which made its debut during Yamaha dealer conferences and press previews held in the United States, Canada, Europe, Australia, New Zealand and South Africa received enthusiastic responses from everyone. The new line-up ranging from the 2hp Single to the 220hp V-6 Special has been developed to fit diversified customer needs, especially with widened pleasure-boat use in mind. In addition, the new line-up created a tremendous sensation when it was introduced to the buying public for the first time in the United States during the Chicago (IMTEC) Show held from Sept. 22 to Sept. 25.



The Strengthened Boat Line-up for '84

Yamaha Marina Hamana-ko

14 quality new models have added to the Yamaha pleasure boat line-up for '84, to meet the recent surge of boating enthusiasm in Japan. These new models were introduced to Yamaha dealers, press personnel and the buying public at Yamaha Marina Hamana-ko from Sept. 8 to Sept. 10.



Leading the way into the motorcycle world '84

Behind all the valid, sensible reasons for buying a motorcycle there's still one fierce, primal urge and, in 1984, Yamaha are going straight for it. We're out to tap the rich vein of sheer excitement at the very core of the motorcycle experience! Motorcycling excitement can come in many ways. From attacking the back roads at speed on a supersports bike less than one step removed from the racetrack. Or by flying in luxury down the freeway fast lanes. By battling off-road with the challenge of nature itself. Or even sneaking smoothly through city traffic while your fellow commuters curse in stationary frustration! Whatever it is about motorcycling that gets your adrenalin pumping, Yamaha has a bike that'll throw the switch. For this is the year that we've pledged to multiply the excitement factor. All across the Yamaha range, the thrill is back!



FJ1100

New potential in the superbike class

It's been some years since we built a big class superbike at Yamaha. Not because we weren't capable but because we preferred to emphasise the comparative values of a good power to weight ratio. Now we've joined the outright horsepower race and, in true Yamaha style, have shot straight to the front with the most awesome superbike so far. The Yamaha FJ1100, a chain drive, in-

line four with double overhead camshaft 16 valve cylinder head. Valves are directly driven from the camshaft with no cam followers, thus reducing valve train power losses. It's a machine, however, that still holds true to the Yamaha ideals of efficient power to weight combinations. Not only is the FJ1100 more powerful than the rest, it's also lighter, narrower and generally more compact! Yamaha's new superbike is a machine that could have come straight from the Bol d'Or starting grid. Styling and aerodynamics are pure endurance racer with high-penetration nose fairing, streamlined front fender shrouding the front fork legs and an engine undercowl with integral spoiler. The racing specification chassis has a main frame of box section,

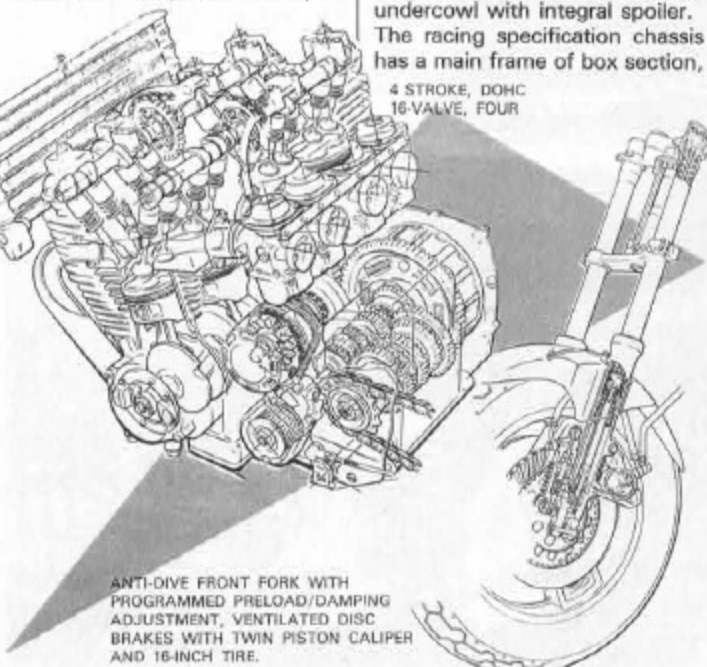

ANTI-DIVE FRONT FORK WITH PROGRAMMED PRELOAD/DAMPING ADJUSTMENT, VENTILATED DISC BRAKES WITH TWIN PISTON CALIPER AND 16-INCH TIRE.

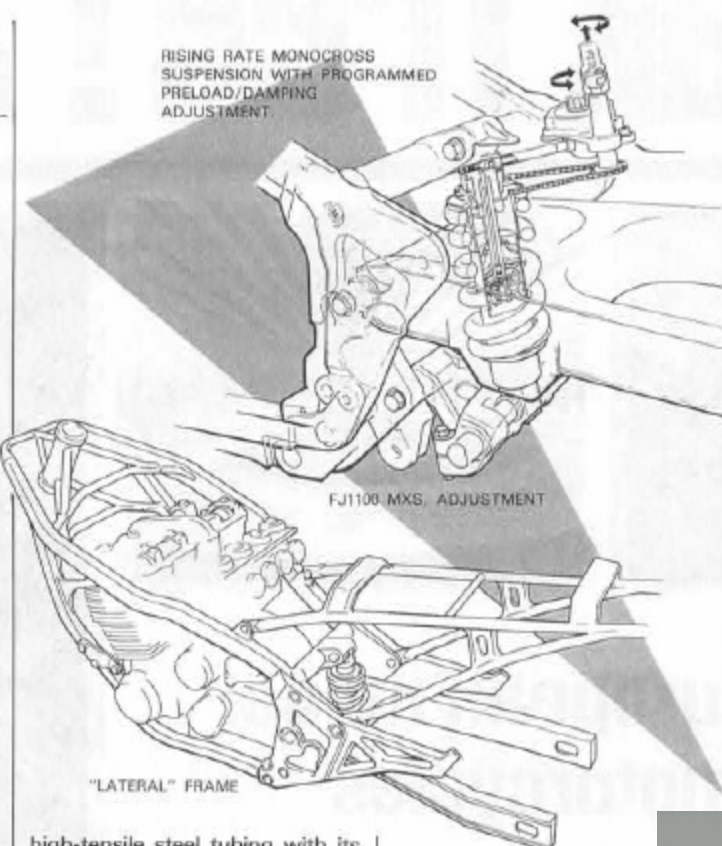

RIISING RATE MONOCROSS SUSPENSION WITH PROGRAMMED PRELOAD/DAMPING ADJUSTMENT

FJ1100 MXS. ADJUSTMENT

"LATERAL" FRAME

high-tensile steel tubing with its top rails joining ahead of the front forks. This gives maximum steering head rigidity and allows the mounting of the fairing and instrument console direct to the forward frame members so that their weight does not detract from the high speed, straight-line stability of the front suspension. A by-product of this 'lateral' frame design is superb accessibility to the engine. The cylinder head is exposed between the top frame tubes while the bottom chassis members are both detachable to facilitate work on the engine's lower end.

High-speed cruising potential

Rising rate Monocross suspension is employed and offers five-way adjustment of both damping and spring pre-load on the single shock absorber. All possible combinations can be dialled in from the outside of the machine via a chain-driven remote control unit. Front suspension is also adjustable, via three pre-set options, again on both damping and spring pre-load. The telescopic forks have 41mm stanchions and a large alloy brace to resist torsional stresses, with anti-dive hydraulics keeping the FJ1100 straight and level under heavy braking. The triple disc brakes are centre-ventilated for quick heat dissipation and operated by new, opposed-piston calipers containing semi-metallic, 'all weather' friction pads. Ultra-wide section 16-inch wheels are used front and rear to gain cornering potential in line with the engine's power output. The high-speed cruising potential of the FJ1100 also has an obvious appeal to long distance touring enthusiasts, which is why we have designed the bike with plenty of space for luggage equipment. The

1983 World Championship series! Even the specification details of the sensational new Yamaha sound more suited to the racetrack than the road but this is not actually the case. The RD500LC is a superbly tractable street machine, using the lessons learned on the racetrack to bring bonuses in terms of both power and safety.

The power bonus comes from the compact, lightweight, 50° V4 two-stroke engine. The most powerful motor ever produced for the 500cc class, performing on a par with rivals twice its size. It features reed valve induction for smoothly-controlled intake flow while the computer-controlled Yamaha Power Valve System (Y.P.V.S.) matches exhaust port timing to engine speed for the maximum-possible spread of torque. Starting with the lower end of the engine, we find that it is in effect two racing-type, twin-cylinder power units geared together. Each of the twin-cylinder blocks has its own crankshaft and these are, in turn, geared to a central mainshaft which takes the power to the transmission. The integral bal-

petrol tank shape will easily accommodate a tank top bag while the tail cowling spoiler has hook-up points for tie-down straps. We may have waited awhile before we decided to build the ultimate superbike but, with the advent of the Yamaha FJ1100, no-one dare question our capabilities any longer!

RD500LC

A Grand Prix racer replica for the road

Here it is at last! The Yamaha RD500LC—the bike that the daydreamers and rumourmongers have been hinting at ever since Kenny Roberts got a grip on the 500cc World Championship and our liquid-cooled RD models established themselves as the most popular sports machines ever made. The Yamaha RD500LC—a true replica of the factory racing machine with which Kenny Roberts won six Grand Prix events in the



RD500LC

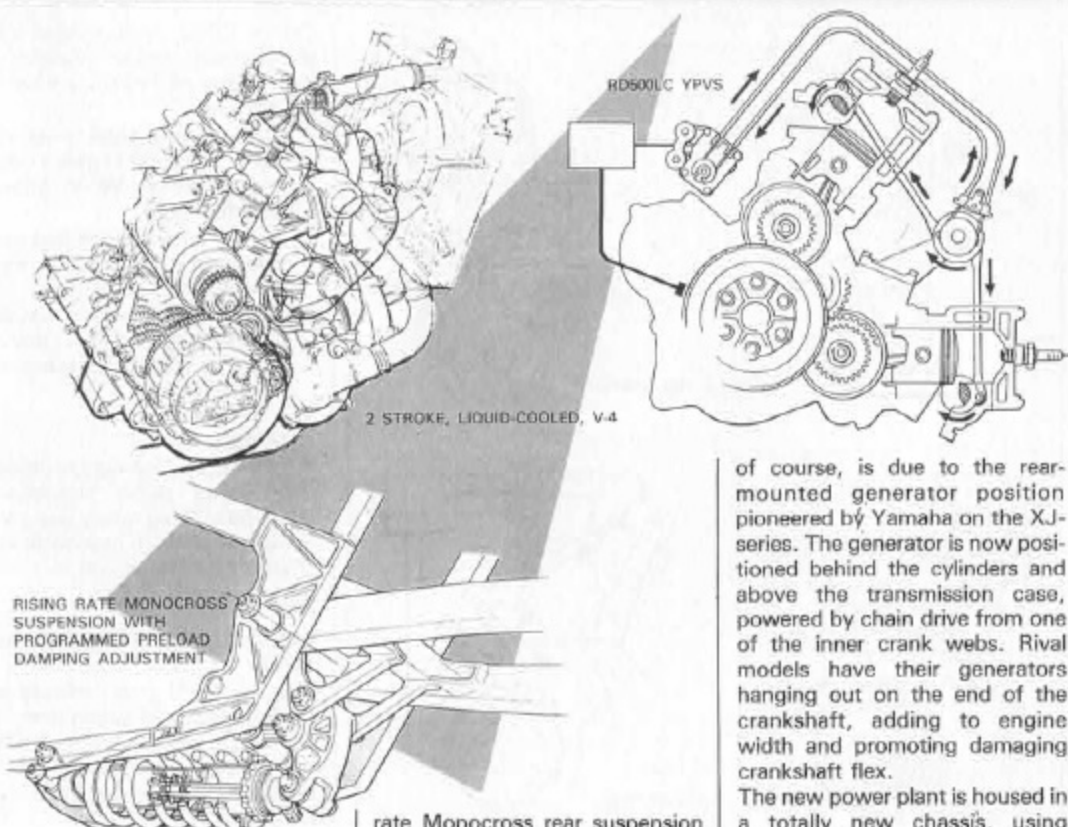

2 STROKE, LIQUID-COOLED, V-4

RIISING RATE MONOCROSS SUSPENSION WITH PROGRAMMED PRELOAD/DAMPING ADJUSTMENT

ever, can not be interchanged. Cylinder heads are one-piece units for each twin cylinder block and are not interchangeable.

An F-1 dominator!

The box-section main frame tubes are widely-spaced to lower the fuel tank position and steering head height, therefore reducing overall frontal area. This has the added advantage of easy accessibility to the upper part of the engine. Front wheel of the RD500LC follows current racing practice and is of 16-inch diameter, fitted with low-profile (120/80) tyre. Rear wheel is of 18 inch diameter with wide-section 130/80 rubber. Both tyres are V-rated for ultra high-speed use. Wheels are of new triple-spoke design, cast in light but superstrong, high-density alloy. The safety bonus comes from the precise, predictable handling of the chassis. This employs rising



RD500LC AIR FILTER CARB FLOW

ancer gear, which smooths out vibration to permit sustained high rpm, is rubber-bushed to reduce backlash. The engine has a diagonally-opposed firing sequence to maintain equal loading on the primary transmission drive gear and its crankcase separates into three pieces. Moving to the upper part of the engine, there are four separate cylinder blocks with special anti-friction coating on the cylinder walls. The upper pair of cylinders are interchangeable from left to right, as are the lower pair. Upper and lower cylinders, how-



XJ600

Big power boost and new chassis

This is the year in which Yamaha have vowed to emphasise their sporting capabilities by heading the performance stakes in as many classes as possible. Few people are likely to contest the claim of the new Yamaha XJ600 in the 550/600cc supersports category. Powering the new XJ600 is a high performing, 598cc version of the

compact in-line four that has proved so successful as the XJ550. It is not, however, merely a bored-out version of the existing motor. Though some of the castings are the same, most of the XJ600 engine shows evidence of re-design or new manufacturing ideas.

A real supersports middleweight

Like all the other engines in the Yamaha XJ range, the XJ600 is generally lighter, narrower and more compact than its rivals. This,

of course, is due to the rear-mounted generator position pioneered by Yamaha on the XJ-series. The generator is now positioned behind the cylinders and above the transmission case, powered by chain drive from one of the inner crank webs. Rival models have their generators hanging out on the end of the crankshaft, adding to engine width and promoting damaging crankshaft flex. The new power plant is housed in a totally new chassis, using Yamaha's famous rising rate Monocross suspension for the first time in the XJ four-stroke sports range.

As a result, the Yamaha XJ600 is a compact, nimble-handling motorcycle with a high performance engine that marks it as a real supersports middleweight. One which Yamaha are confident will be right amongst the market leaders in an increasingly important area of sales.

XJ750

A sporting seven-fifty

Yamaha's XJ models (ranging from 400 to 900cc) have become the primary choice for many riders shopping in the middleweight marketplace. They offer excellent power-to-weight ratios, compact dimensions, fuel efficiency and nimble handling—all the virtues that a good middleweight should have.

This year Yamaha introduce a 750cc version that, for the first time, has dual-role potential. Housed in the sporting XJ900 rolling chassis is a new 750cc power unit to produce a bike that is equally effective as either sports machine or fast tourer.

A number of new improvements

The new engine displaces 749cc from a 65 x 56.5mm bore and stroke (stroke is 0.4mm longer than its 1982 predecessor). Significant changes in the twin-cam cylinder head include high lift



XJ750

cams, bigger (by 1mm) inlet and exhaust valves with ports opened up to match, big-bore 33mm carburetors and a large capacity air cleaner from the XJ900. Compression ratio rises from 9.2:1 to 9.8:1 while the free-flow exhaust system is also derived from the XJ900. Finally, the drive shaft from that bigger model is utilised to cope with the over-10% power boost that results from all of these changes.

In fact, there's a lot of our very successful XJ900 incorporated in the new XJ750. The chassis retains the variable-adjustment rear shocks and ventilated brake discs but uses large diameter telescopic forks without the anti-dive mechanism and air damping of the XJ900 components. Most visible item that the two bikes share is the new-for-1984 head fairing, mounted direct to the frame rather than on the front forks. This eliminates the inertia of the fairing and instrument console, and increases rider protection. In essence, the Yamaha XJ750 shares all the good points of its bigger brother but sacrifices just one or two of the high-tech

touches in the interest of preserving the solid middleweight values of good performance at a sensible price.

XJ900

Improved aerodynamics

The line leader in our highly-popular XJ-series, the XJ900, looks even more exciting for 1984 with the addition of a new head fairing and engine undercowl. The new fairing has larger dimensions for better rider coverage with effective air penetration and is frame-mounted so that its weight does not affect steering at speed. The lower part of the fairing is duct-shaped to direct air over the cylinder head area, so the air scoops mounted beneath the fuel tank on last year's model are now discarded. Otherwise, the Yamaha XJ900—which was one of most successful introductions in 1983—remains basically unchanged for the coming year.



XVZ12TD

XVZ12TD (XVZ12T)

Last word in touring luxury

For the first time in the history of the company, Yamaha have produced a motorcycle purely and simply for the long distance touring rider. The Yamaha XVZ12T/12TD is a 'full dress' touring bike in the American idiom and it sets new standards of luxury and mechanical-sophistication for the two-wheeled world.

The Yamaha XVZ12TD was originally designed for the endless freeways of the USA. But what better bike is there for a fully-loaded cruise across the motorways of Europe? The first Yamaha offered in

Europe exclusively for the long distance touring rider.

The XVZ12TD is centred around the biggest capacity Yamaha power plant ever built. A 1200cc vee-four with liquid-cooling, hydraulic clutch and shaft drive for quiet operation with total reliability. Thanks to its double overhead camshaft, 16 valve cylinder head design, the XVZ12TD has all the power you'll ever need...and plenty still in reserve. Yamaha's Induction Control System (YICS) delivers fuel efficiency with the widest possible spread of torque. And on a 1200cc vee-four, that spread is wide indeed! The XVZ12TD does have a five speed gearbox but once you're up to cruising speeds you can drive it on the throttle just as if it had automatic transmission! Smooth speed is what the biggest Yamaha is all about, which is why there's a crankshaft balancer to eliminate the vibration that's a major source of discomfort on rival tourers. Rider discomfort just cannot be tolerated on a long distance machine. So the XVZ12TD has a full fairing integrated into its compact bodywork, an orthopaedically-designed seat with separate sections for rider and passenger and adjustable handlebars and footrests that allow an individually-tailored riding position. Large-capacity luggage equipment is part of the basic specification and added luxury comes in the form of a stereo cassette player and radio with a sensor that automatically adjusts the volume according to the surrounding noise levels!

1984 Yamaha Motorcycle Range (Europe)

One of the safest, most efficient machines

Technically, the XVZ12TD is loaded with features that make it one of the safest, most efficient, machines on the road. The Unified Brake System links the left front and rear disc brakes so that they are both operated, in perfect balance, from the foot pedal. The right front disc is operated by hand lever. The Computer Levelling Air Suspension System (CLASS) machines on the road. The Unified and rear suspension spring tensions to suit your own weight and load requirements at the push of

a microcomputer control button. More computer technology monitors vital machine functions and conveys any problem to the rider via dashboard warning lights. The heavy duty front forks are braced against torsional flexing and incorporate an anti-dive system that prevents the hefty machine from dipping its nose under braking. The use of Monocross rear suspension, plus the under-seat location of the 20-litre fuel tank, combines with the wide-profile, 16-inch rear wheel to drop the centre of gravity as low as possible to achieve a safe and stable ride.

No motorcycle is better-equipped for long distance touring than the Yamaha XVZ12TD. So, if you're the kind of rider who thinks in terms of crossing continents rather than mere countries, then it's your kind of bike!

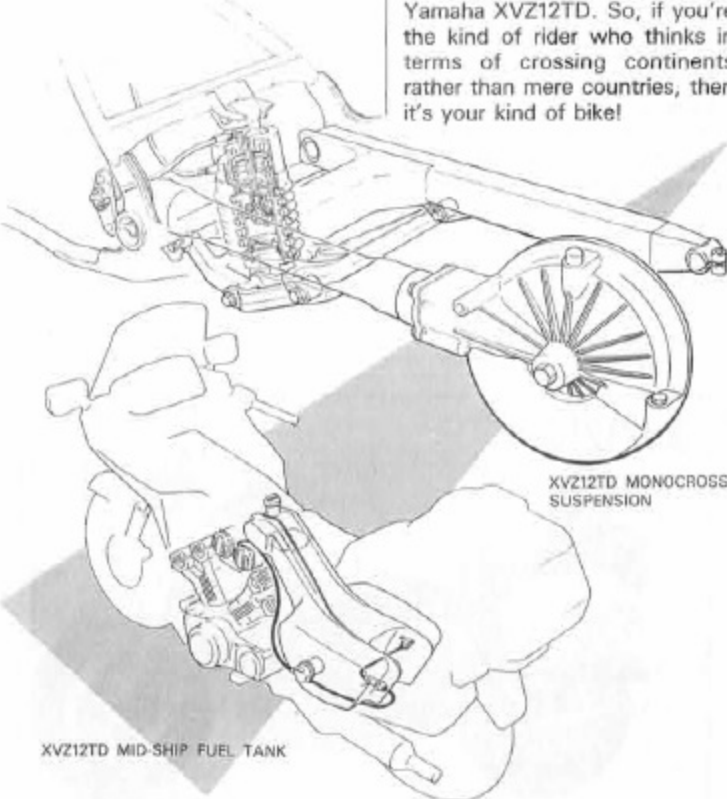

XVZ12TD MONOCROSS SUSPENSION

XVZ12TD MID-SHIP FUEL TANK

DT125LC

Maintaining Yamaha's lead in an exciting class

In recent years there have been some dramatic changes in the 125cc class. Once just another fairly-insignificant lightweight category, it is now a battlefield of technological advances and marketing rivalry. Without any false modesty, we're proud to say that Yamaha started the 125cc renaissance by having the courage and foresight to use our most modern, race-developed technical innovations in what was previously a motorcycling backwater. We began to build 125cc contenders that were real motorcycles. Full-sized bikes with small-capacity, high performance engines rather than dressed-up

lightweights that were 'all show and no go'. What we built were bikes like the Yamaha DT125LC—one of the models which blew the class wide apart as soon as it appeared on the scene. This motocross-inspired 'supertrail' bike is the leader in its class and has been a runaway success for Yamaha. But we're not getting complacent! Our DT125LC development is a continuing programme of improvement on a bike that's already the best! The 1984 version of the Yamaha DT125LC hammers that point home in the most emphatic possible fashion. Its specification is closer than ever to the Grand Prix motocross racers from which the bike is derived!

More powerful but even more manageable

The liquid-cooled engine now utilises both the Yamaha Energy

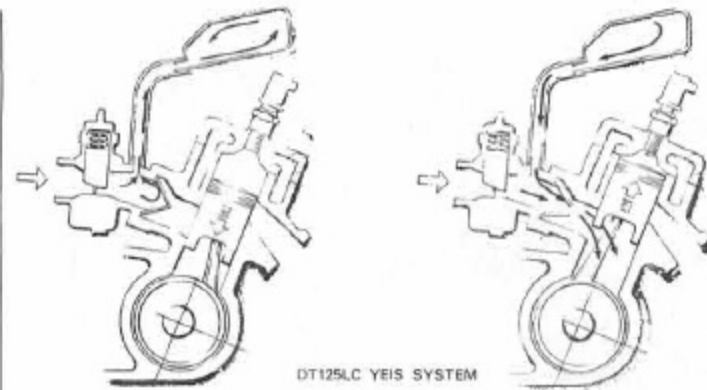

DT125LC YFIS SYSTEM

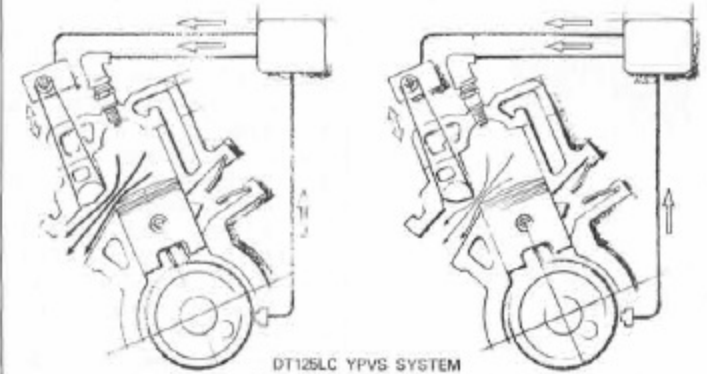

DT125LC YPVS SYSTEM

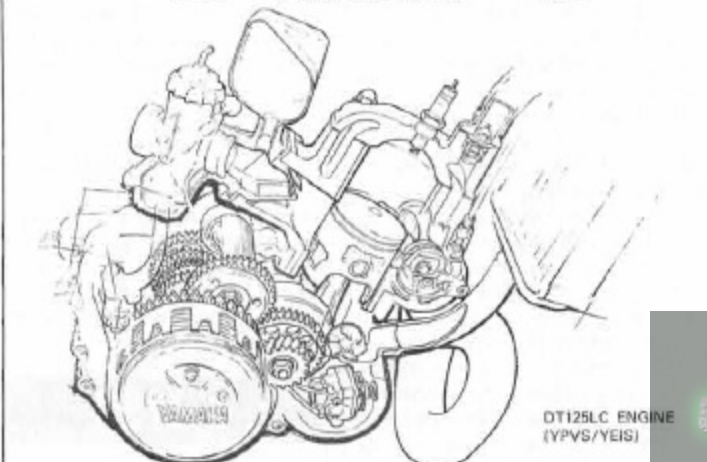

DT125LC ENGINE (YPVS/YFIS)

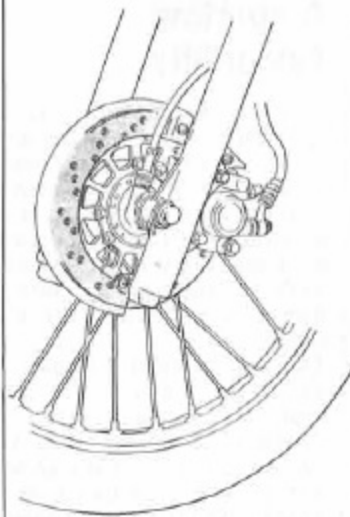

DT125LC DISC BRAKE/PLASTIC SHIELD

Induction System and Yamaha Power Valve System for the most effective possible combination of outright power and big-pulling torque. The DT125LC has further increased its power advantage over anything else in its class and now is even more manageable. For the new power unit, there's a brand new chassis. Again a near-replica of our Grand Prix racers with rising rate Monocross suspension that allows 210mm of wheel movement. Leading axle front forks have rugged 36mm stanchions plus 240mm travel and carry the latest Yamaha off-road development, our all-weather front disc brake. Proved on the XT600 Ténéré, we have now brought disc brakes into the lightweight enduro classes. The specification is completed by frame mounted passenger footrests and a strong luggage carrier

behind the seat. Styling of the 1984 DT125LC has been updated again, keeping pace with the aggressive look of today's factory motocross racers. At first glance, the Yamaha DT125LC seems to be an out and out, high performance motorcycle. Closer inspection of engine and chassis components emphasises that fact beyond any possible doubt!

The '84 TZ250 was developed with the following design concepts to offer higher performance than its predecessor.

1. High performance potential that is sufficient to gain a good position in the World Championship races.
2. Light, strong chassis that provides good handling at high speeds.
3. Engine characteristics that are controllable enough for novice riders as well as for seasoned riders.

CHASSIS

A lightweight, high-rigidity chassis that allows stable high-speed riding by utilising newly designed components which have sufficient strength for lateral and torsional force.

ELECTRICALLY-CONTROLLED YPVS

The new YPVS gives more precise control of exhaust timing than the previous mechanically-controlled unit, allowing engine to deliver higher horsepower over wider rpm ranges.

IMPROVED COOLING EFFICIENCY

To cope with increased engine power and the consequent heat, the '84 TZ250 uses a newly developed, larger-capacity radiator.

BRAKES

To give strong, yet stable braking for faster lap time, the '84 TZ250 features improved brake system. The front brake has a new, lighter master cylinder. The rear brake uses a thinner, lighter disc rotor, new friction pads and newly designed master cylinder.

ENGINE

The TZ250 power unit features optimal combustion chamber design with high compression ratio to give efficient fuel burning. The specifically developed pistons with 0.8mm-thick rings offer low frictional losses and high top-end power. The large-capacity expansion chambers and carefully designed intake manifolds provide smooth, efficient cylinder filling, while the 38mm-diameter carburetors ensure quick throttle response.

LIGHT WEIGHT

The rear shock absorber uses a superlight, high-tensile steel coil spring. The expansion-chamber exhaust pipes have light, efficient aluminium silencers. The clutch cover and oil pump cover are made of cast magnesium. The front brake uses aluminium caliper. The fairing is composed of thin, lightweight FRP skins. The aluminium-alloy brake pedal is specially coated to give higher strength.

TZ250

The result of GP victories

Since its introduction, Yamaha TZ250 has been one of the most popular and competitive production road racers. In the 1983 season Carlos Lavado, a Venezuelan Yamaha rider, won the 250cc class of the World Road Racing Championships on his TZ250. This also brought Yamaha its 11th manufacturer's Championship in the class.

TZ250

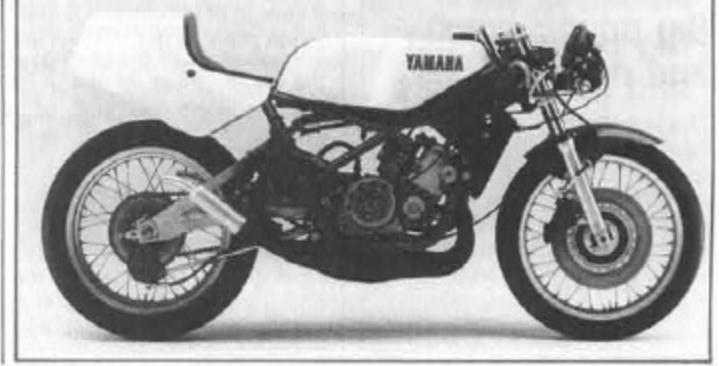

TY250

A real competitive machine

The 1984 TY250 is unique in being the only production trials motorcycle to use a single-shock Monocross suspension system. Yamaha's decision to use this system is hardly surprising as the company pioneered its use on the street and in all other forms of competition. Its effectiveness as a trials suspension has been immediately proved by the Isle of Man win and top placings in other British events on the test program.

Technical close-up

The new, single-cylinder two-stroke is built to be as light and compact as possible with a narrow crankcase width that is essential to any successful trials bike. It has a 'square' bore to stroke ratio of 68x68mm and the cylinder head uses a new dual stage squish area. In section, the squish band resembles a bell, with a flat outer rim tapered sharply up to the central spark plug. It is designed specifically for low-down power and even-running a minimal engine speeds. Torque is further improved by the heavy, full-circle flywheels used on the Yamaha YZ490 motocross racers. Crank web balance holes have been plugged to add even more to flywheel weight and to increase the primary compression ratio...another aid to low-end power and smoothness. The six-speed gearbox has its first four ratios closely-spaced so that the rider can make gearchanges actually in the trials sections if necessary.

The chassis of the 1984 TY250 is a classic 'diamond frame' with the engine forming the lower part of the parallelogram and acting as a stressed member. Below the motor is a flat alloy grid plate that is, in turn, shrouded by a contoured 5mm aluminium sump guard. In addition to 325mm or ground clearance, therefore, the TY250 crankcases are doubly protected against rock-inflicted damage! Yamaha's monocross suspension is used for the first time on a trials machine. It features a single De Carbon-type shock absorber with gas/oil damping and a six-way adjustable coil spring. The shock unit is connected to the tapered box section swinging arm by forged aluminium linkage arms which are specially-cranked to exert more leverage as the suspension nears the end of its compression. Thus damping is increased in a rising rate to spring compression, giving a light ride on smooth terrain and more and more resistance as the bumps get bigger. An added benefit of this system to the trials rider is the fact that the suspension has added momentum on its rebound stroke, thus actively helping the bike to climb over rocks or roots!



YT60

Safe, stable and so much fun

As the popular PW50 is to dirt bikes, so the YT60 relates to the bigger Yamaha Tri-Moto three-wheelers. It's a scaled-down but fully-equipped Tri-Moto with many of its fittings aimed specifically at rider safety. Children and their parents will appreciate the stability of three

wheels for low speed riding. An important confidence builder to any youngster just learning to ride a powered vehicle. The YT60 is powered by what is essentially a 59cc version of Yamaha's QT50 moped engine, complete with its maintenance-free shaft drive. The shaft is totally-enclosed so that there is no possibility of injury...always a hazard with chain drive, which is why Yamaha have chosen a shaft on all machines designed for very young children. The little Yamaha 'trike' rides on big, low-pressure balloon tyres,

Outstanding safety features

Footrests are integral with the widespread, flexible rear fenders and are positioned so that it is impossible for the rider to trap his leg in the rear wheels. On the grab bar at the rear, behind the deep-cushioned, protective seat, there is a unique engine stop switch. A long cord is linked to a pull-out connector in this switch so that the parent can actually have his young 'learner rider' on the end of a lead, just like walking a dog! If the child begins to go too fast for the parent's peace of mind (whether inadvertently or not!), a quick tug will disconnect the switch and stop the engine. The parent is in control until he or she is confident that the child has mastered riding techniques in safety!

There are other built-in safety factors to prevent a child going too quickly, too soon. A power reduction plate cuts down the diameter of the exhaust port but can be removed when the child is actually capable of handling additional speed and acceleration.

YZ80/125 250/490

Production motocrossers developed by world champions

Since Heikki Mikkola put together successive wins for Yamaha in the 500cc class for both 1977 and 1978, there have been the 250cc class Championships of Neil Hudson and Danny LaPorte in 1981 and 1982 plus Hakan Carlqvist's well-deserved 500cc title that climaxed the 1983 season. All of these World Championship wins—not to mention our first title, courtesy of Hakan Andersson in the 250cc class ten years ago—have had a distinct effect on the quality of production motocross racers built by Yamaha.

Yamaha YZ80

On the 1984 version of the YZ80, the improvements are made in lessening the weight, extending the suspension capabilities and spreading the horsepower more across the rpm range. Weight has been out by two kilograms over the 1983 version by various detail modifications. None of them are drastic changes on their own account but collectively they reduce the weight of the YZ80 from 62 to 60kg. Engine performance has been slightly increased for 1984 and, perhaps even more important, this power has been spread across the lower end of the rpm scale to make the bike more manageable in all conditions. Getting the power efficiently to the ground is the job of the Monocross suspension, which has been increased in travel this year, from 245 to 260mm. This is

achieved by a new shock absorber with a 90mm stroke. Front forks gain the same 15mm extra travel, wheel movement now being 255mm. Front and rear wheels of the YZ80 both use the new Yamaha rim-to-rim "Z" spokes, cranked for positive location where they pass through the hub but actually holding the rim in tension rather than simply connecting it to the hub flange. The wheels stay true longer, spoke tension needs less adjustment and they have a stronger resistance to deflection.

Yamaha YZ125

Engine power has been increased by new porting in the cylinder body, on exhaust side. Two sub-ports have been cut in the cylinder barrel, one on each side of the main exhaust tract. These speed up the extraction of exhaust gases, feeding them through matching sub-ports in the body of the Yamaha Power Valve System. These YPVS sub-ports are graduated to the same degree as the main valve cutaway, so that exhaust port timing is varied on both them and the main tract. Swinging arm length has gone up by 38mm and the relay arms for the Monocross rising rate suspension altered to suit the other chassis changes. The rear shock absorber has been shortened by 47mm to 440mm overall length but its stroke is only reduced from 109 to 103mm.

The rear shock is also reduced 6mm in diameter (to 40mm). This allows a more compact chassis layout as well as reducing overall weight. The shock absorber has a smaller remote reservoir which makes for easier compression damping changes via an adjuster actually on the reservoir. On the equipment side, the fuel tank capacity goes up from 7 to 7.5 litres, there's a new, longer rear fender, re-designed side covers and a radiator cover specifically-shaped to keep it out of the way of the rider's knees and lower legs. The radiator itself is now protected by a tubular guard.

Yamaha YZ250

For 1984, the YZ250 promises to be even more competitive, with significant improvements to both engine and suspension components. It gets the same porting changes as the YZ125, with two exhaust sub-ports that link with the YPVS system to speed up the exhaust process. A large capacity air filter is easily accessible via the machine's side covers while the exhaust pipe is now routed down the right hand side and its noise level reduced from 110dba to 108dba without any loss of power. The silencer is made of lightweight aluminium.

The water pump axle is strengthened for total cooling reliability. New closer compression ratios enable the rider to better use the added horsepower of the 1984 machine.

A new, compact shock absorber is fitted, being 38mm shorter than the 500mm 1983 component. The front forks also now have adjustable compression damping (like on the YZ125) and the front wheel utilises Yamaha's new rim-to-rim "Z" spokes.

On the rear wheel, these are used on one side only, so as not to interfere with the sprocket mounting.

There's a new 8.5 litre fuel tank, a redesigned radiator cover plus a tubular guard to protect it in a crash and an even-more accurate electronic ignition system, new for 1984.

Again, the Yamaha development department's attention to detail will make the YZ250 an even stronger contender for next season. Even more competitive than a bike already capable of winning a Grand Prix in stock production form!

Yamaha YZ490

There are changes in both engine and chassis specifications that will make the 1984 Yamaha YZ490 a potent weapon for the private rider in the highly-competitive 500cc class.

Inlet and exhaust port timings have been changed for more performance and carburettor size goes up from 38 to 40mm.

The reed valve Torque Induction now uses eight reeds instead of six and breathes through a new, double-element filter. This filter can be removed through the side panel for easy cleaning. Cylinder head fin shape has been changed and an air-scoop installed on left-hand side of the engine for better cooling. There's an extra hold-down bolt (seven instead of six) to gain a better seal between head and barrel.

The chassis gives increased ground clearance and uses a more compact shock absorber for the Monocross suspension for better weight centralization and a lower centre of gravity. Though the shock is 38mm shorter, at 462mm, its stroke has been increased from 112 to 116mm.

Both front forks and rear suspension have adjustable compression damping, the rear adjustment being made directly at the remote fluid reservoir (The rear shock is also adjustable in rebound damping). Wheelbase of the powerful YZ490 has been shortened by 25mm for 1984, to make it more controllable on tighter track sections and braking performance is improved by a larger rear brake (now up to 150mm diameter from 130mm).

YZ490



1983 WORLD CHAMPION

**HAKAN
CARLOVIST**
WITH
YAMAHA YZM500

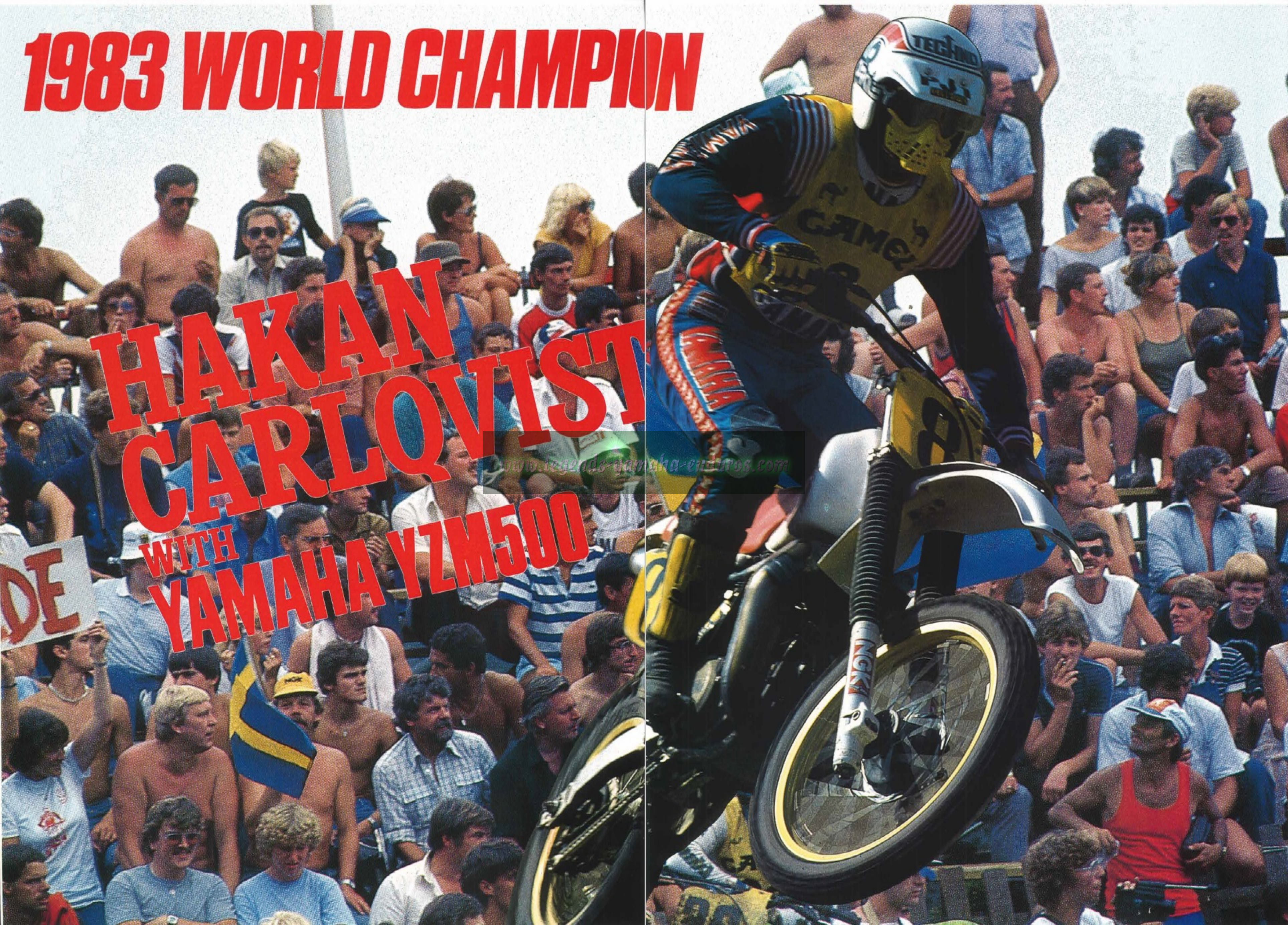

1984 Yamaha Outboard Range

Yamaha News New Model Line-up

MEETING MORE DIVERSIFIED CUSTOMER NEEDS

* Each model is prepared in two different graphic designs.
 * V-6 and V-4 series models which are introduced here are ones for the markets of North America and Australia.
 * 3-cylinder and smaller models are ones for Europe and other overseas markets.



1 cyl.

Close

2

• Engine Type: 2-st. Single Cylinder
 • Displacement: 43cc(2.62ci) • Bore & Stroke: 39x36mm (1.54x1.42in)
 • Horsepower: 2hp @5500rpm
 • RPM Range: 4000-5000rpm • Ignition System: Magneto • Starting System: Manual

5

• Engine Type: 2-st. Single Cylinder
 • Displacement: 103cc(6.29ci) • Bore & Stroke: 54x45mm (2.13x1.77in)
 • Horsepower: 5hp @5500rpm • RPM Range: 4500-5500rpm • Ignition System: CDI • Starting System: Manual

15

• Engine Type: 2-st. Twin Cylinders • Displacement: 246cc(15.0ci) • Bore & Stroke: 56x50mm (2.21x1.97in) • Horsepower: 15hp @5500rpm • RPM Range: 4500-5000rpm • Ignition System: CDI • Starting System: Manual (Electric)

4

• Engine Type: 2-st. Single cylinder
 • Displacement: 83cc(5.07ci) • Bore & Stroke: 50x42mm (1.97x1.65in) • Horsepower: 4hp @5500rpm • RPM Range: 4500-5500rpm • Ignition System: CDI • Starting System: Manual

20

• Engine Type: 2-st. Twin Cylinders • Displacement: 430cc • Bore & Stroke: 67x61mm (2.64x2.40in) • Horsepower: 20hp @5500rpm • RPM Range: 4500-5500rpm • Ignition System: CDI • Starting System: Manual (Electric)

25

• Engine Type: 2-st. Twin cylinders • Displacement: 430cc(26.2ci) • Bore & Stroke: 67x61mm (2.64x2.40in) • Horsepower: 25hp @5500rpm • RPM Range: 4500-5500rpm • Ignition System: CDI • Starting System: Manual (Electric)

6

• Engine Type: 2-st. Twin Cylinders • Displacement: 165cc(10.1ci) • Bore & Stroke: 50x42mm (1.97x1.65in) • Horsepower: 6hp @5500rpm • RPM Range: 4000-5000rpm • Ignition System: CDI • Starting System: Manual (Electric and Manual)

15

• Engine Type: 2-st. Twin Cylinders • Displacement: 246cc(15.0ci) • Bore & Stroke: 56x50mm (2.21x1.97in) • Horsepower: 15hp @5500rpm • RPM Range: 4500-5000rpm • Ignition System: CDI • Starting System: Manual (Electric)

25

• Engine Type: 2-st. Twin cylinders • Displacement: 430cc(26.2ci) • Bore & Stroke: 67x61mm (2.64x2.40in) • Horsepower: 25hp @5500rpm • RPM Range: 4500-5500rpm • Ignition System: CDI • Starting System: Manual (Electric)

8

• Engine Type: 2-st. Twin Cylinders • Displacement: 165cc(10.1ci) • Bore & Stroke: 50x42mm (1.97x1.65in) • Horsepower: 8hp @5500rpm • RPM Range: 4500-5500rpm • Ignition System: CDI • Starting System: Manual (Electric and Manual)

20

• Engine Type: 2-st. Twin Cylinders • Displacement: 430cc • Bore & Stroke: 67x61mm (2.64x2.40in) • Horsepower: 20hp @5500rpm • RPM Range: 4500-5500rpm • Ignition System: CDI • Starting System: Manual (Electric)

30

• Engine Type: 2-st. Twin Cylinders • Displacement: 496cc(30.27ci) • Bore & Stroke: 72x61mm (2.83x2.40in) • Horsepower: 30hp @5500rpm • RPM Range: 4500-5500rpm • Ignition System: CDI • Starting System: Manual (Electric)

9.9

• Engine Type: 2-st. Twin Cylinders • Displacement: 246cc(15.0ci) • Bore & Stroke: 56x50mm (2.21x1.97in) • Horsepower: 9.9hp @5500rpm • RPM Range: 4500-5500rpm • Ignition System: CDI • Starting System: Manual (Electric)

115

• Engine Type: 2-st. 90°V-4 • Displacement: 1730cc(105.6ci) • Bore & Stroke: 90x68mm(3.54x2.68in) • Horsepower: 115hp @5500rpm • RPM Range: 4500-5500rpm • Ignition System: CDI • Starting System: Electric

140

• Engine Type: 2-st. 90°V-4 • Displacement: 1105.6ci • Bore & Stroke: 90x68mm(3.54x2.68in) • Horsepower: 140hp @5500rpm • RPM Range: 4500-5500rpm • Ignition System: CDI • Starting System: Electric

3 cyl.

40

• Engine Type: 2-st. In-line Three Cylinders • Displacement: 698cc (42.6ci) • Bore & Stroke: 67x66mm(2.64x2.60in) • Horsepower: 40hp @5500rpm • RPM Range: 4500-5500rpm • Ignition System: CDI • Starting System: Manual (Electric)

V4 cyl.

150

• Engine Type: 2-st. 90°V-6 • Displacement: 2596cc(158.4ci) • Bore & Stroke: 90x68mm(3.54x2.68in) • Horsepower: 150hp @5500rpm • RPM Range: 4500-5500rpm • Ignition System: CDI • Starting System: Electric

V6 cyl.

175

• Engine Type: 2-st. 90°V-6 • Displacement: 2596cc(158.4ci) • Bore & Stroke: 90x68mm(3.54x2.68in) • Horsepower: 175hp @5500rpm • RPM Range: 4500-5500rpm • Ignition System: CDI • Starting System: Electric

50

• Engine Type: 2-st. In-line Three Cylinders • Displacement: 698cc (42.6ci) • Bore & Stroke: 67x66mm(2.64x2.60in) • Horsepower: 50hp @5500rpm • RPM Range: 4500-5500rpm • Ignition System: CDI • Starting System: Electric

175

• Engine Type: 2-st. 90°V-6 • Displacement: 2596cc(158.4ci) • Bore & Stroke: 90x68mm(3.54x2.68in) • Horsepower: 175hp @5500rpm • RPM Range: 4500-5500rpm • Ignition System: CDI • Starting System: Electric

200

• Engine Type: 2-st. 90°V-6 • Displacement: 2596cc(158.4ci) • Bore & Stroke: 90x68mm(3.54x2.68in) • Horsepower: 200hp @5500rpm • RPM Range: 4500-5500rpm • Ignition System: CDI • Starting System: Electric

60

• Engine Type: 2-st. In-line Three Cylinders • Displacement: 849cc (51.8ci) • Bore & Stroke: 72x69.5mm (2.83x2.74in) • Horsepower: 60hp @5500rpm • RPM Range: 4500-5500rpm • Ignition System: CDI • Starting System: Electric

220

• Engine Type: 2-st. 90°V-6 • Displacement: 2596cc(158.4ci) • Bore & Stroke: 90x68mm(3.54x2.68in) • Horsepower: 220hp @5500rpm • RPM Range: 4500-5500rpm • Ignition System: Micro Computer Ignition • Starting System: Electric

200

• Engine Type: 2-st. 90°V-6 • Displacement: 2596cc(158.4ci) • Bore & Stroke: 90x68mm(3.54x2.68in) • Horsepower: 200hp @5500rpm • RPM Range: 4500-5500rpm • Ignition System: CDI • Starting System: Electric

70

• Engine Type: 2-st. In-line Three Cylinders • Displacement: 849cc (51.8ci) • Bore & Stroke: 72x69.5mm (2.83x2.74in) • Horsepower: 70hp @5500rpm • RPM Range: 4500-5500rpm • Ignition System: CDI • Starting System: Electric

KEROSENE 40

• Engine Type: 2-st. Twin Cylinders • Displacement: 698cc • Bore & Stroke: 78x70mm • Horsepower: 40hp @5500rpm • RPM Range: 4500-5500rpm • Ignition System: CDI • Starting System: Manual

ENDURO 75

• Engine Type: 2-st. In-line Three Cylinders • Displacement: 1140cc (69.6ci) • Bore & Stroke: 82x72mm(3.23x2.83in) • Horsepower: 75hp @5500rpm • RPM Range: 4500-5500rpm • Ignition System: CDI • Starting System: Manual





THE THRILL IS BACK!

YZ

YZ80

- Type: Liquid-cooled, 2-stroke, torque induction, single cylinder
- Displacement: 79 cc • Ignition system: C.D.I.
- Transmission: Constant mesh 6-speed • Fuel tank capacity: 5.0 lit.
- Tire (front, rear): 80/90-17, 110/80-14

YZ125

- Type: Liquid-cooled, 2-stroke, torque induction, single cylinder
- Displacement: 123 cc • Ignition system: C.D.I.
- Transmission: Constant mesh 6-speed • Fuel tank capacity: 7.5 lit.
- Tire (front/rear): 3.00-21/4.00-18

YZ250

- Type: Liquid-cooled, 2-stroke, torque induction, single cylinder
- Displacement: 246 cc • Ignition system: C.D.I.
- Transmission: Constant mesh 5-speed
- Fuel tank capacity: 8.5 lit.
- Tire (front/rear): 3.00-21/5.10-18

YZ490

- Type: 2-stroke, torque induction, single cylinder
- Displacement: 487 cc • Ignition system: C.D.I.
- Transmission: Constant mesh 4-speed • Fuel tank capacity: 10.5 lit.
- Tire (front/rear): 3.00-21/5.10-18

DT

DT125C

- Type: Liquid-cooled, 2-stroke, torque induction, single cylinder
- Displacement: 123 cc • Ignition system: C.D.I.
- Transmission: Constant mesh 6-speed • Fuel tank capacity: 10 lit.
- Brake (front/rear): Disc/Drum • Tire (front/rear): 2.75-21/4.10-18

TY

TY250

- Type: 2-stroke, torque induction, single cylinder
- Displacement: 246 cc • Ignition system: C.D.I.
- Transmission: Constant mesh 6-speed • Fuel tank capacity: 3.5 lit.
- Brake (front/rear): Drum/Drum • Tire (front/rear): 2.75-21-4 PR/4.00-18

RD

RD500LC

- Type: Liquid-cooled, 2-stroke, V-4 cylinder
- Displacement: 462 cc • Ignition system: C.D.I.
- Transmission: Constant mesh 6-speed • Fuel tank capacity: 23 lit.
- Brake (front/rear): Dual disc/Disc
- Tire (front, rear): 120/80 V 16, 130/80 V 18

TZ

TZ250

- Type: Liquid-cooled, 2-stroke, piston-valve, twin cylinder
- Displacement: 249 cc • Ignition system: C.D.I.
- Transmission: Constant mesh 6-speed • Fuel tank capacity: 23.5 lit.
- Brake (front/rear): Disc/Disc • Tire (front, rear): 3.00/3.75-18, 3.75/5.00-18

FJ

FJ1100

- Type: 4-stroke, DOHC, 16-valve, V-4 cylinder
- Displacement: 1,097 cc • Ignition system: T.C.I.
- Transmission: Constant mesh 5-speed • Fuel tank capacity: 24.5 lit.
- Brake (front/rear): Dual disc/Disc
- Tire (front, rear): 120/80 V 16, 150/80 V 16

XVZ

XVZ12T/TD

- Type: Liquid-cooled, 4-stroke, DOHC, 16-valve, V-4 cylinder
- Displacement: 1,198 cc • Ignition system: T.C.I.
- Transmission: Constant mesh 5-speed
- Fuel tank capacity: 20 lit.
- Brake (front/rear): Dual disc/Disc
- Tire (front, rear): 120/90-18-65 H, 140/90-16-71 H

YT

YT60

- Type: 2-stroke, reed valve, single cylinder
- Displacement: 59 cc • Ignition system: C.D.I.
- Transmission: Single speed automatic
- Fuel tank capacity: 4.0 lit. • Tire (front/rear): 15x7/15x7

XJ

XJ600

- Type: 4-stroke, DOHC, 4-cylinder
- Displacement: 598 cc • Ignition system: T.C.I.
- Transmission: Constant mesh 6-speed • Fuel tank capacity: 19 lit.
- Brake (front/rear): Dual disc/Disc
- Tire (front, rear): 90/90 H 18, 110/90 H 18

XJ750/(900)

- Type: 4-stroke, DOHC, 4-cylinder
- Displacement: 749 cc (863 cc) • Ignition system: T.C.I.
- Transmission: Constant mesh 5-speed • Fuel tank capacity: 22 lit.
- Brake (front/rear): Dual disc/Disc • Tire (front, rear): 100/90 V 18, 120/90 V 18

1984 YAMAHA NEW BOAT LINE-UP

RESPONDING TO A SURGE OF DEMAND FOR QUALITY PLEASURE BOATS...

Along with the strengthened ranges of motorcycles and outboards, the Yamaha new boat line-up also comes with a lot of significant improvements and exciting features, responding to a surge of demand for quality pleasure boats. The new boat line-up for the Japanese market which was recently unveiled at Yamaha Marina Hamana-ko consists of 14 models (7 new, 4 redesigned, 2 minor modified and 1 varied models), each of which has been designed and built in full quest of higher cruising performance, better steering characteristics and excellent livability.

STRIPE SERIES

STR-21RX⁰ b-1/b

new model



Yamaha's first bow rider-equipped multi-purpose family runabout

- LOA: 6.65 m • Beam: 2.41 m • Draft: 1.11 m
- Hull weight: 820 kg(OB), 850 kg(IO)
- Recommended horsepower: 175 PS(OB), 188 PS(IO)
- Maximum horsepower: 200 PS(OB), 188 PS(IO)
- No. of crew: 8

ROW BOAT

ROW-13

new model



Increased stability against the wind
Improved layout for pleasure fishing

- LOA: 3.90 m • Beam: 1.16 m • Draft: 0.46 m
- Hull weight: 63.6 kg • No. of crew: 3

PACIFIC CRUISER-26

new model



An ample cockpit for pleasure fishing

- LOA: 7.95 m • Beam: 2.92 m • Draft: 1.53 m
- Hull weight: 2,000 kg • Recommended horsepower: 188 x 2(PS) • No. of crew: 11

DINGHIES

YAMAHA-11 Mini Hopper II

redesigned model



Increased performance, improved rigging and renewed styling

- LOA: 3.43 m • Waterline length: 3.16 m • Beam: 1.32 m
- Draft (C.B-up/C.B-down): 0.10 m/0.75 m • Hull weight: 45 kg
- Sail area: 5.7 m²

YAMAHA-18

new model



A multi-purpose family type

- LOA: 5.50 m • Waterline length: 5.23 m • Beam: 1.87 m • Draft (C.B-up/C.B-down): 0.15 m/1.15 m
- Hull weight: 195 kg
- Sail area: 14.7 m² • No. of crew: 5

YAMAHA-13 cicala II

redesigned model



A grade-up sloop type

- LOA: 4.09 m • Waterline length: 3.89 m • Beam: 1.73 m
- Draft (C.B-up/C.B-down): 0.15 m/1.03 m
- Hull weight: 93 kg • Sail area: 11.50 m²

SPORTSFISHING BOATS

FISH-22 II yd II

minor modified model



Coming with a new turbo diesel

- LOA: 6.64 m • Beam: 2.18 m • Draft: 0.98 m
- Hull weight: 615 kg • Recommended horsepower: 75 PS
- No. of crew: 7

FISH-24 II yd

new model



A turbo diesel-powered high performance boat

- LOA: 7.34 m • Beam: 2.42 m • Draft: 1.12 m
- Hull weight: 990 kg • Recommended horsepower: 107 PS
- No. of crew: 10

FISH-26⁰ g

new model



V-type hull with outstanding seaworthiness and stability
Sufficient speed and high fuel efficiency with a 150 PS outboard

- LOA: 7.80 m • Beam: 2.55 m • Draft: 1.19 m
- Hull weight: 1,170 kg • Recommended horsepower: 150 PS
- Maximum horsepower: 175 • No. of crew: 12

FISHING CRUISERS

FC-27 IV

redesigned model



V-type hull with increased seaworthiness and stability; inboard direct drive system

- LOA: 7.95 m • Beam: 2.65 m • Draft: 1.35 m
- Hull weight: 1,450 kg • Recommended horsepower: 158 PS
- No. of crew: 8

FC-33 III

minor modified model

Increased lateral stability
High performance, fuel-saving Yamaha MD-45K diesel engine

- LOA: 9.90 m • Beam: 2.82 m • Draft: 1.59 m
- Hull weight: 2,170 kg • Total tonnage: 7.05 tons
- Recommended horsepower: 214 tons
- No. of crew: 10

U SERIES

U-23 BFDX

redesigned model



Top model of the U line for added boating pleasure

- LOA: 6.86 m • Beam: 1.96 m • Draft: 0.98 m
- Hull weight: 490 kg • Recommended horsepower: 55 PS
- Maximum horsepower: 70 PS • No. of crew: 7

SAILING CRUISERS

Top class quarter-ton boat

- LOA: 7.98 m • Waterline length: 6.40 m • Beam: 2.80 m • Draft: 1.55 m • Hull weight: 2,045 kg
- Ballast weight: 650 kg
- Sail area: 27.00 m² • Auxiliary engine 7.5 PS

YAMAHA-26 EX

variation



A high performance cruiser which is far above club racer standards

- LOA: 8.97 m • Waterline length: 7.36 m • Beam: 3.18 m • Draft: 1.75 m • Hull weight: 3,650 kg
- Ballast weight: 1,300 kg
- Sail area: 41.30 m² • Auxiliary engine 15 PS

YAMAHA-30 c II

new model

