

# YAMAHA

# WR250ZD

# ASSEMBLY MANUAL



[www.legends-yamaha-ent.com](http://www.legends-yamaha-ent.com)

# SYMBOLS USED IN ASSEMBLY MANUAL

In order to simplify descriptions in assembly manuals, the following symbols are used:

 : Coat with lithium soap base grease.

 : Tighten to 10 Nm.  
(10 Nm = 1.0 m•kg = 7.2 ft•lb)

 : Front ward of the vehicle.

 : Provide a clearance.

 : Install so that the arrow mark faces upward.

 : Apply a motor oil.

 : Made of rubber or plastics.

A	B	C	D	E

A: Ref No. (indicating the order or operations.)

B: Part name

C: Quantity of parts per vehicle.

D: Place where parts are held.

V: Stored in vinyl bag.

C: Stored in carton box.

S: Fixed inside the crate and/or contained in the styrofoam tray (upper or lower).

\*: Temporarily installed or secured.

E: Size: or material of parts.

d/D: Diameter of part.

ℓ : Length of part.



ex. 5 (0.2) = 5 mm (0.2 in)

[www.legends-yamaha-enduros.com](http://www.legends-yamaha-enduros.com)

**WR250ZD**  
**ASSEMBLY MANUAL**  
©1991 by Yamaha Motor  
Corporation U.S.A.  
1st Edition, July 1991

All rights reserved. Any reprinting or  
unauthorized use without the written  
permission of Yamaha Motor  
Corporation U.S.A.  
is expressly prohibited.

Printed in U.S.A.  
LIT-11666-07-92

# FOREWORD

This Assembly Manual contains the information required to reassembly of the Yamaha machines correctly prior to delivery to the customer. Since some external parts of the machine have been removed at the Yamaha factory for convenience of packing, assembly by the Yamaha dealer is required. It should be noted that the reassembled machine should be thoroughly cleaned, inspected, and adjusted prior to delivery to the purchaser.

## NOTICE

The service specifications given in this assembly manual are based on the model as manufactured. Modifications and significant changes in specifications and/or procedures will be forwarded to Authorized Yamaha Dealers. The procedures below are described in the order that the procedures are carried out correctly and completely. Failure to do so can result in poor performance and possible harm to the machine and/or rider.

Particularly important information is distinguished in this manual by the following notations:



The Safety Alert Symbol means ATTENTION! BECOME ALERT! YOUR SAFETY IS INVOLVED!

### **WARNING**

Failure to follow **WARNING** instructions could result in severe injury or death to the machine operator, a bystander, or a person inspecting or repairing the machine.

### **CAUTION:**

A CAUTION indicates special precautions that must be taken to avoid damage to the machine.

### **NOTE:**

A NOTE provides key information to make procedures easier or clearer.

# SETUP PROCEDURES

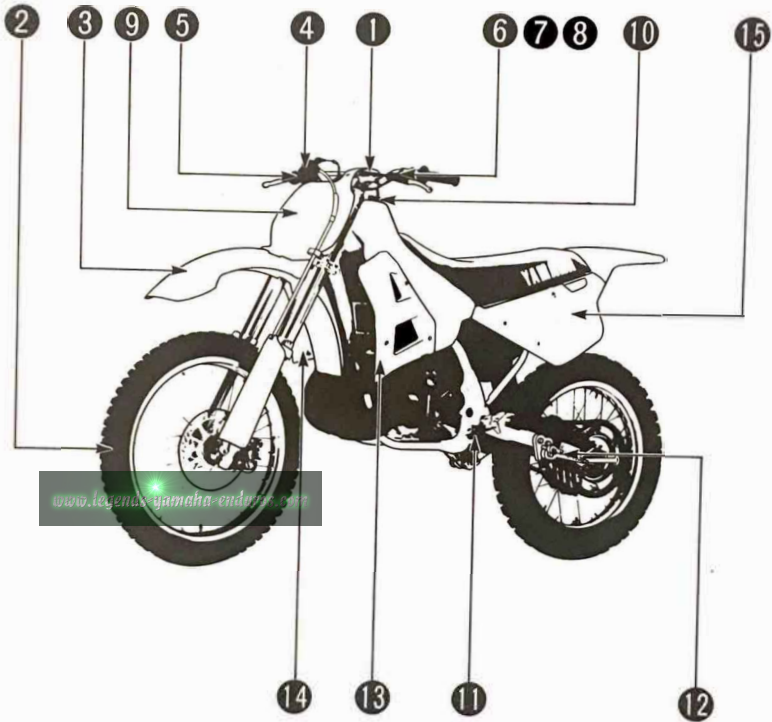

## 1. Handlebar

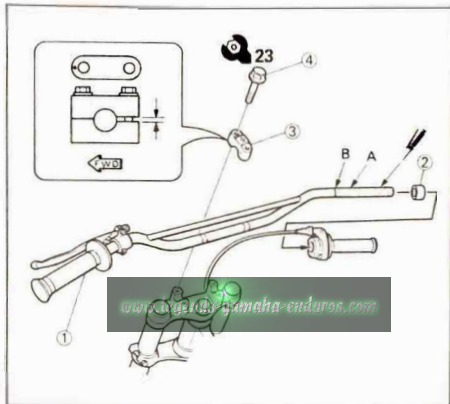

1	Handlebar	1	S	
2	Collar	1	V	
3	Handlebar upper holder	2	V	
4	Flange bolt	4	V	$d = 8$ (0.32), $l = 35$ (1.38);

- A: Clean the right handlebar end. Apply the light coat grease.
- B: Before inserting the handlebar into the throttle grip, make sure the collar is installed.

### ▲WARNING

Proper cable and lead routing is essential to assure safe machine operation. REFER TO "CABLE ROUTING".

### NOTE:

The throttle cables should not be twisted, and make certain the throttle grip rotates on the handlebar freely, without binding.

## 2. Front wheel

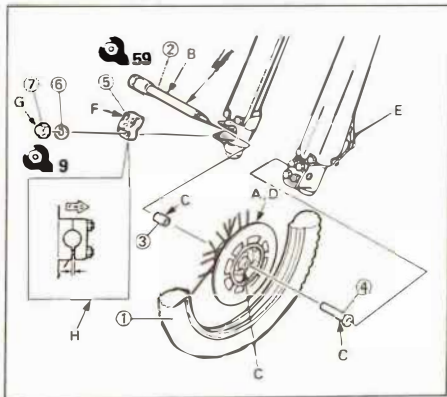

1	Front wheel	1	S	
2	Front wheel axle	1	✳	$d = 15$ (0.59), $l = 187$ (7.3)
3	Collar 1	1	V	$d = 15$ (0.59)
4	Collar 2	1	V	$d = 15$ (0.59)
5	Front wheel axle holder	1	✳	$d = 6$ (0.24)
6	Spring washer	4	✳	$d = 6$ (0.24)
7	Cap nut	4	✳	$d = 6$ (0.24)

- A: Clean the brake disc.
- B: Clean the front wheel axle.
- C: Clean the collar.
- D: **▲WARNING**  
Take care not to put grease on the brake disc or inner surface of the brake pads. If you do so, clean using a rag dampened with a solvent. Foreign material on braking surface can cause impaired braking action.
- E: Do not depress the brake lever when the wheel is off the machine as the brake pads will be forced to shut.
- F: Make sure the arrow mark with the axle holder is pointed upward.
- G: Tighten the pinch nuts temporarily before tightening the axle.
- H: Secure the wheel axle with the axle holder.
- CAUTION:**  
First tighten the nuts on the upper side of the axle holder, and then tighten the nuts on the lower side.

### 3. Front fender

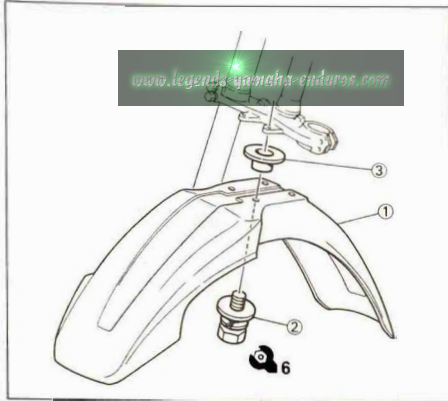

1	Front fender	1	S	
2	Hexagon bolt with spring washer and plain washer	4	V	d = 6 (0.24), $t = 20$ (0.78)
3	Collar	4	V	d = 6 (0.24)

### 4. Throttle grip

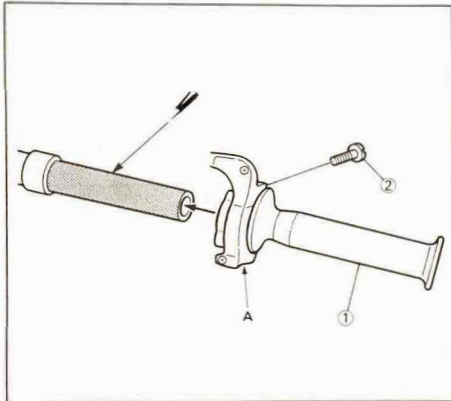

1	Throttle grip	1	*	
2	Panhead screw	2	*	d = 5 (0.20)

A: Slip the throttle grip over the right handlebar to the limit and slide it back about 2 mm (0.08 in).

#### **⚠WARNING**

**CHECK THE THROTTLE GRIP FOR SMOOTH ACTION!**

### 5. Front brake master cylinder

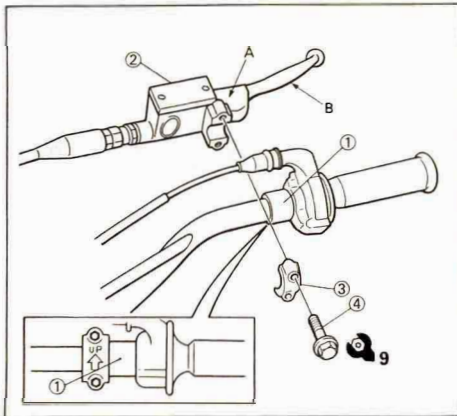

1	Collar	1	*	
2	Front brake master cylinder	1	*	
3	Master cylinder bracket	1	V	
4	Flange bolt	2	V	d = 6 (0.24), $t = 25$ (0.98)

A: Lubricate the pivoting part of the brake lever.

Recommended lubricants:  
Yamaha cable lube

B: Check the brake lever for smooth action.

#### **⚠WARNING**

Proper hose routing is essential to assure safe machine operation. REFER TO "CABLE ROUTING."

## 6. Clutch cable/Boots

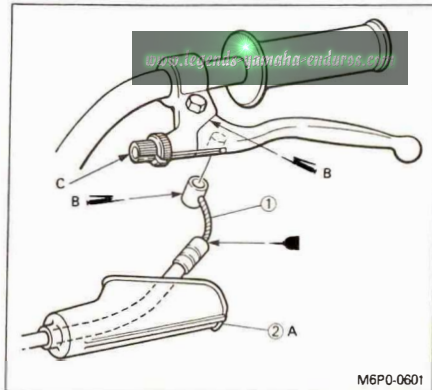

1	Clutch cable	1	*	
2	Boot	1	*	

- A: Install the boot to the clutch cable.  
 B: Lubricate the pivoting part of the clutch lever.

Recommended lubricants:  
 Yamaha Cable Lube or motor oil

- C: To install the clutch cable, be sure to proceed as follows:  
 a. Fully loosen the locknut on the lever holder, and screw in the adjuster on the lever holder until tight. Next, align the slit in the adjuster and locknut with the slit in the lever holder.  
 b. Insert the cable end into the lever hole, and hook the outer cable end onto the locknut, then squeeze the lever. Next, while pulling the outer cable in the direction opposite to the lever, release the lever quickly while releasing it seat the outer cable into the adjuster.

**NOTE:**  
 Check the clutch lever for smooth action. REFER TO "ADJUSTMENT AND PREDELIVERY SERVICE."

**WARNING**  
 Proper cable routing is essential to assure safe machine operation. REFER TO "CABLE ROUTING."

## 7. Engine stop button

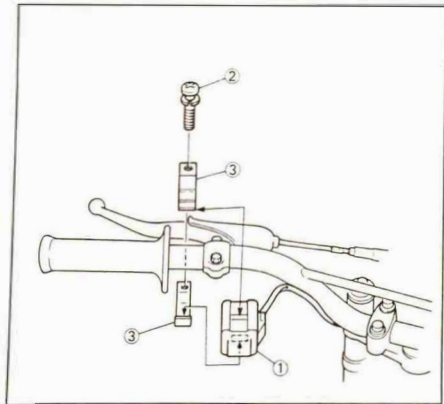

1	Engine stop button	1	*	
2	Panhead screw with spring washer	1	V	$d = 3 (0.12), \ell = 14 (0.55)$
3	Engine stop button holder (Upper and lower)	2	V	

## 8. Handlebar band

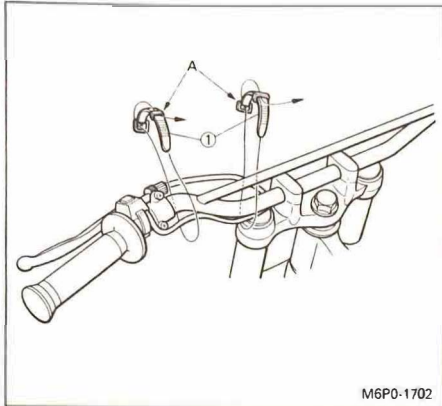

1	Handlebar band	2	V	
---	----------------	---	---	--

A: Clamp the engine stop switch lead.

## 9. Number plate

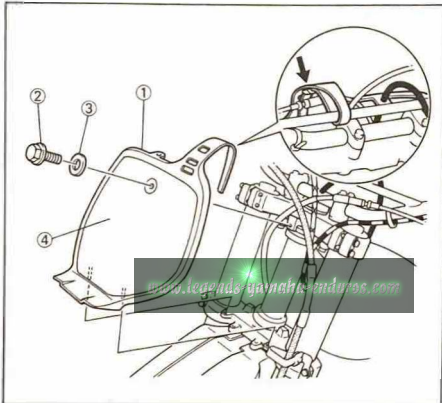

1	Number plate	1	S	
2	Hexagon head bolt	1	V	d = 6 (0.24), ℓ = 12 (0.47)
3	Plain washer	1	V	d = 6 (0.24)
4	Graphic	1	C	

## 10. Fuel tank breather hose

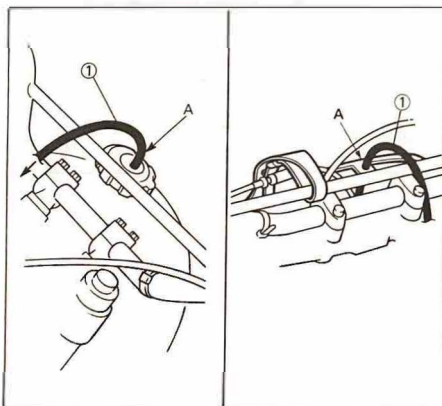

1	Fuel tank breather hose	1	S	Rubber
---	-------------------------	---	---	--------

A: Connect one end of the breather hose to the fuel tank filler cap, and insert the other end into the hose guide hole of number plate.

**NOTE:**  
Refer to "CABLE ROUTING".



### 11. Footrest

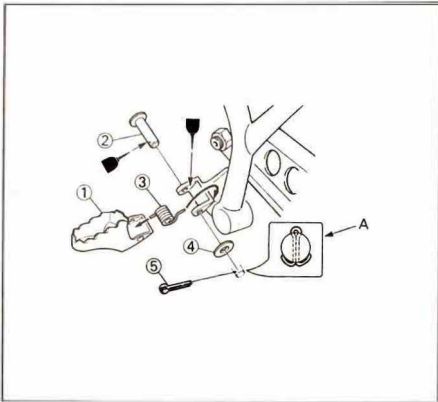

1	Footrest	1	V	
2	Clevis pin	1	V	d = 10 (0.39)
3	Return spring	1	V	
4	Plain washer	1	V	d = 10 (0.39), D = 16 (0.62)
5	Cotter pin	1	V	

A: Bend the end of cotter pin.

### 12. Sidestand

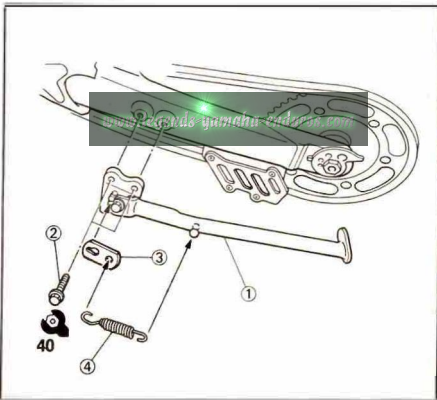

1	Sidestand	1	S	
2	Bolt with LOCTITE	2	V	D = 10 (0.39)
3	Sidestand bracket	1	C	
4	Spring	1	C	

### 13. Radiator cover (left)

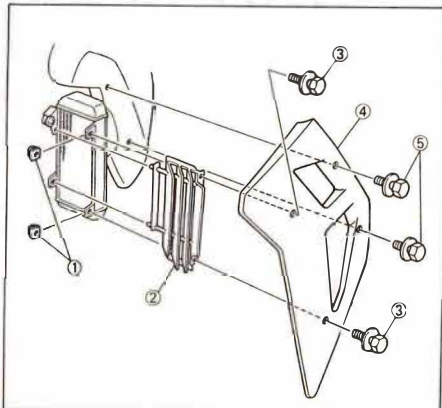

1	Spring nut	2	*	d = 6 (0.24)
2	Plate	1	C	
3	Hexagon bolt with plain washer	2	V	d = 5 (0.24), $\ell = 16$ (0.63)
4	Radiator cover (Left)	1	S	
5	Hexagon bolt with plain washer	2	V	d = 6 (0.20), $\ell = 14$ (0.55)

#### 14. Radiator cover (Right)

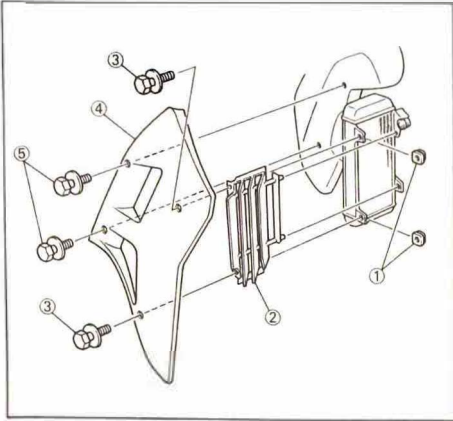

1	Spring nut	2	V	d = 5 (0.20)
2	Plate	1	C	
3	Hexagon bolt with plain washer	2	V	d = 5 (0.20), ℓ = 16 (0.63)
4	Radiator cover (Right)	1	S	
5	Hexagon bolt with plain washer	2	V	d = 6 (0.24), ℓ = 14 (0.55)

#### 15. Side cover (Right)

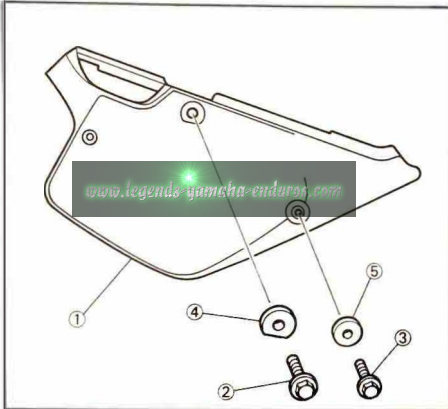

1	Side cover	1	C	
2	Flange bolt	1	V	d = 8 (0.32), ℓ = 16 (0.63)
3	Flange bolt	1	V	d = 6 (0.24), ℓ = 12 (0.47)
4	Collar	1	V	d = 8 (0.32)
5	Collar	1	V	d = 6 (0.24)

## CABLE ROUTING

### CAUTION:

Proper cable and lead routing is essential to insure safe machine operation.

- ① Throttle cable
- ② Brake hose
- ③ Fuel tank breather hose
- ④ Clutch cable
- ⑤ "ENGINE STOP" button lead
- ⑥ Cable guide
- ⑦ Band
- ⑧ "ENGINE STOP" button
- ⑨ Lever holder
- ⑩ Protector
- ⑪ Breather hose guide hole

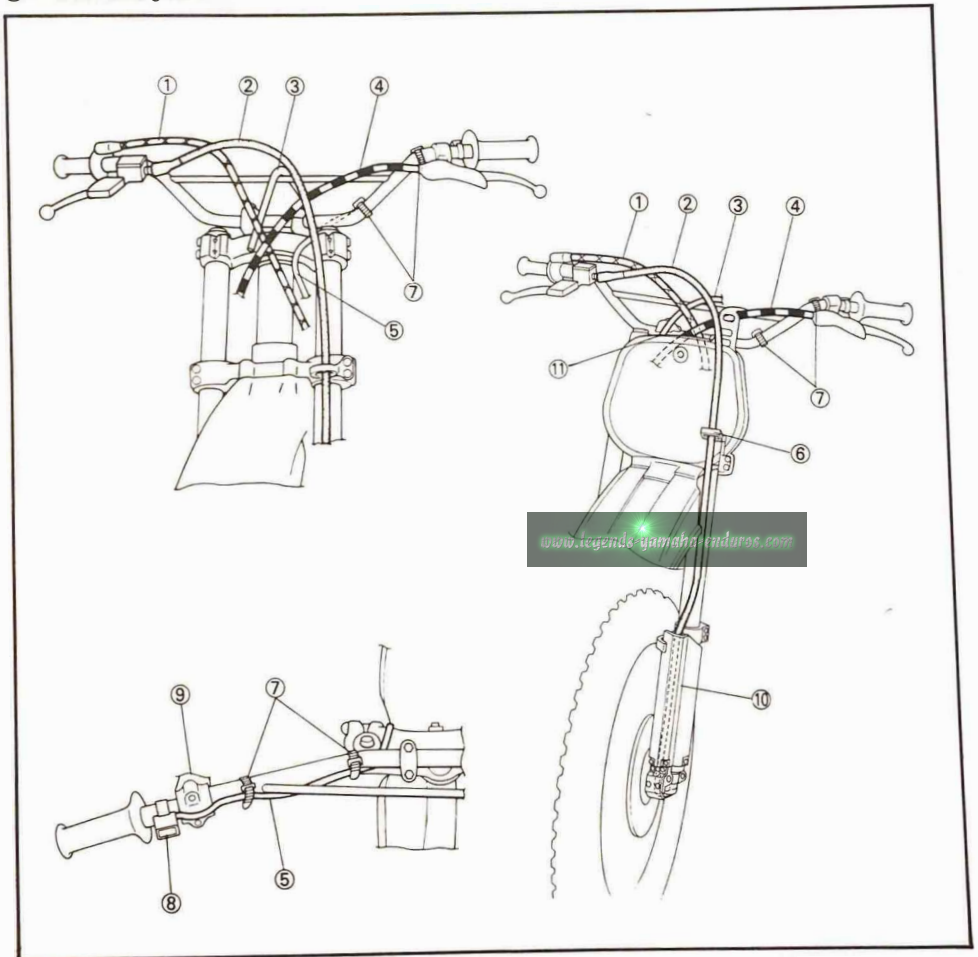

# ADJUSTMENTS AND PREDELIVERY SERVICE

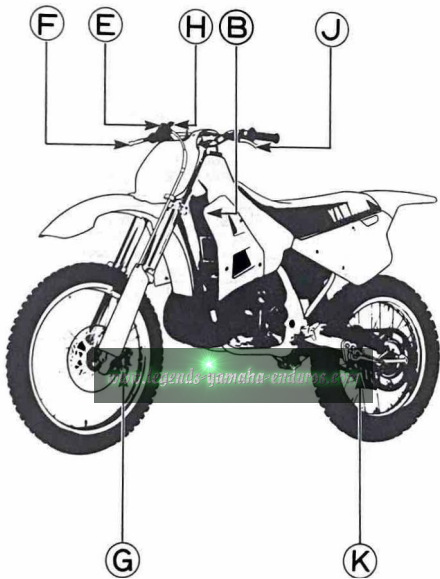
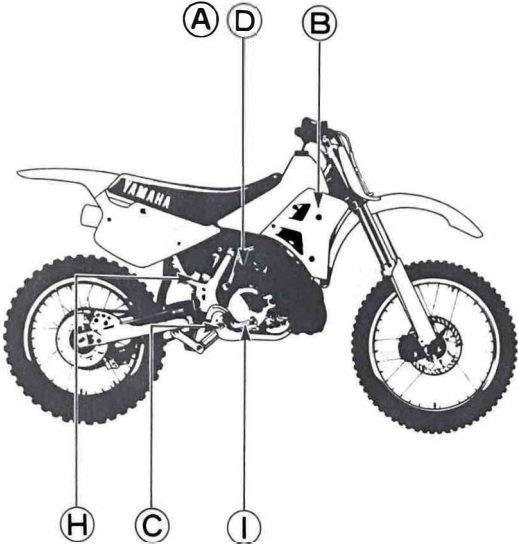

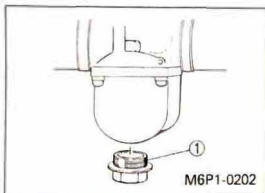

1. Drain plug

### A. Fuel draining

1. Turn the fuel cock to "OFF".
2. Put a rag under the carburetor so fuel does not contact the crankcase.
3. Loosen the drain plug and drain the standing fuel.

### ▲WARNING

#### FUEL IS HIGHLY FLAMMABLE:

- Always turn off the engine when draining.
- Take care not to spill any fuel on the engine or exhaust pipe(s)/muffler(s) when draining.
- Never drain fuel while smoking or in the vicinity of an open flame.

4. Retighten the drain plug securely.

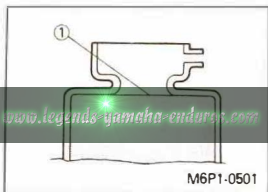

1. Coolant level

### B. Coolant level

1. Check
  - a. Place the machine on a level place.
  - b. Remove the radiator cap and check the coolant level in the radiator tank when the engine is cold.

2. Adjust  
To increase coolant level, add the water to proper level.

Recommended water:  
Tap water (Soft water)

### CAUTION:

Hard water or salt water is harmful to the engine parts. You may use boiled water or distilled water, if soft water is unavailable.

### ▲WARNING

Do not remove the radiator cap when the engine is hot.

### NOTE:

Be sure the machine is positioned straight up when checking the coolant level; a slight tilt toward the side can produce false readings.

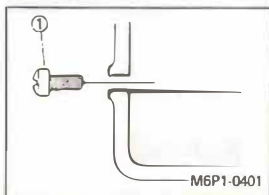

1. Checking bolt

### C. Transmission oil level

#### NOTE:

To check the oil level, the machine must stand VERTICALLY with its both wheels on the ground. A slight tilt toward the side can produce false readings.

1. Check
  - a. Place the machine on a level place.
  - b. Warm up the engine for a few minutes.
  - c. Stop the engine.
  - d. Remove the checking bolt.

2. Adjust  
To increase oil level, add the oil to proper level.

Recommended oil:  
Yamalube 4 (10W-30) or SAE 10W30 type SE motor oil  
Oil capacity (Periodic change):  
0.75 L (0.66 Imp qt, 0.79 US qt)

### CAUTION:

Do not add any chemical additives to the oil. The transmission oil also lubricates the clutch, and additives could cause the clutch to slip.

#### NOTE:

Wait a few minutes until the oil level settles before checking.

- e. The oil level is satisfactory if it is up to the hole bottom brim.

#### NOTE:

Be sure the machine is positioned straight up when checking the oil level.

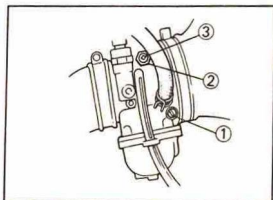

1. Pilot air screw
2. Locknut
3. Throttle stop screw

### D. Idle Speed

1. Check
  - a. Start the engine and warm it up for a few minutes.
  - b. Check the engine idle speed.

Engine idle speed: As desired

2. Adjust
  - a. Screw in the pilot air screw ① until it is lightly seated.
  - b. Back out by specified number of turns.

Pilot air screw:  
1-3/4 turns out

- c. Loosen the locknut ② on the throttle stop screw ③ and turn the screw until the idle is at the desired rpm.
- d. Turn the pilot screw ① in or out in 1/8 turn increments to achieve the highest rpm with just the pilot screw.
- e. Once again, turn the throttle stop screw ③ to attain the desired idle rpm, and tighten the locknut ②.

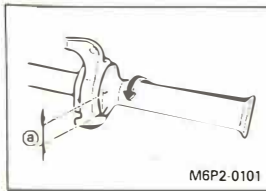

a. Free play

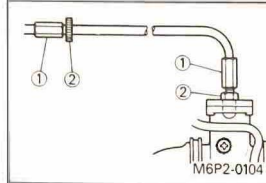

1. Adjuster  
2. Locknut

### E. Throttle grip free play

1. Check

Free play:  
3 – 5 mm (0.12 – 0.20 in)

2. Adjust
  - a. Loosen the locknut.
  - b. Turn the adjuster in or out until the adjustment is suitable.
  - c. Tighten the locknut.

#### NOTE:

- Before adjusting the throttle cable free play, the engine idling speed should be adjusted.
- After adjustment, start the engine and check throttle operation. Turn the handlebars from lock to lock and note if the engine speeds up; if it does, the cable adjustment is too tight and must be readjusted.

#### CAUTION:

After adjusting, turn the handlebar to right and left and make sure the engine idling does not run faster.

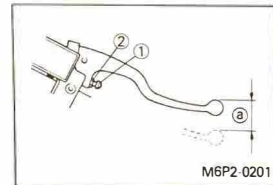

1. Adjuster  
2. Locknut  
a. Free play

### F. Front brake lever free play

1. Check

Free play:  
10 – 20 mm (0.40 – 0.80 in)

2. Adjust
  - a. Loosen the locknut.
  - b. Turn the adjuster in or out until the adjustment is suitable.
  - c. Tighten the locknut.

#### NOTE:

Make sure the brake is working properly.

#### WARNING

A soft or spongy feeling in the brake lever can indicate the presence of air in the brake system. This air must be removed by bleeding the brake system before the machine is operated. Air in the system will result in greatly diminished braking capability and can result in loss of control and an accident. Inspect and bleed the system if necessary.

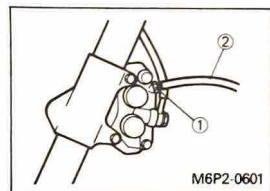

1. Bleed screw  
2. Transparent hose

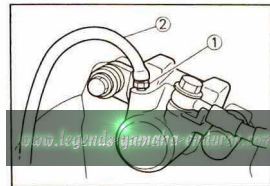

1. Bleed screw  
2. Transparent hose

### G. Bleeding the brake system

#### WARNING

Bleed the brake system if:

- The system has been disassembled.
- A brake hose has been loosened or removed.
- The brake fluid is very low.
- The brake operation is faulty.

A loss of braking performance may occur if the brake system is not properly bled.

#### Air bleeding steps:

- a. Add proper brake fluid to the reservoir.
- b. Install master cylinder cap.  
Be careful not to spill any fluid or allow the reservoir to overflow.
- c. Connect the clear transparent hose (4.5 mm, 0.18 in inside dia.) tightly to the caliper bleed screw ①.
- d. Place the other end of the hose into a container.
- e. Slowly apply the brake lever or pedal several times.
- f. Pull the lever in or push down on the pedal. Hold the lever or pedal in this position.

- g. Loosen the bleed screw and allow the lever or pedal to travel towards its limit.
- h. Tighten the bleed screw when the lever or pedal limit has been reached; then release the lever or pedal.
- i. Repeat steps (e) to (h) until all of the air bubbles have been removed from the systems.

#### NOTE:

If bleeding is difficult, it may be necessary to let the brake fluid system stabilize for a few hours. Repeat the bleeding procedure when the tiny bubbles in system have disappeared.

- j. Add brake fluid (DOT #4) until the reservoir is full.

#### WARNING

Check the operation of the brake after bleeding the brake systems.

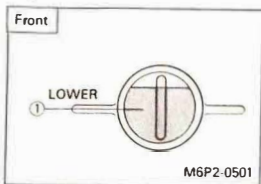

1 "LOWER" level

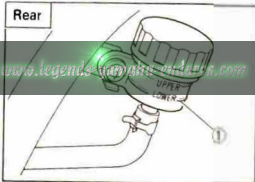

1. "LOWER" level

#### H. Brake fluid level

1. Check  
The brake fluid level is satisfactory if it is over the "LOWER" level.
2. Adjust  
To increase brake fluid level, add the brake fluid to proper level.

Recommended brake fluid:  
DOT #4

#### NOTE:

Check the operation of the brake after refilling with the brake fluid.

#### WARNING

- Use only designated quality brake fluid to avoid poor brake performance.
- Refill with same type and brand of brake fluid; mixing fluids could result in poor brake performance.
- Be sure that water or other contaminants do not enter master cylinder when refilling.
- Clean up spilled fluid immediately to avoid erosion of painted surfaces or plastic parts.

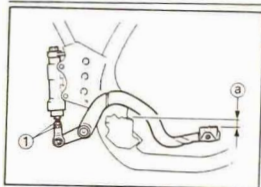

a. Pedal position

#### I. Rear brake pedal position

1. Check

Brake pedal position:  
Zero mm (Zero in)

2. Adjust
  - a. Loosen the adjusting nuts.
  - b. Turn the adjusting nuts until the pedal height is within specified height.
  - c. Tighten the adjusting nuts.

#### WARNING

- Adjust the pedal height between the Maximum and the Minimum as shown. (In this adjustment the bolt end should protrude out of the lower adjusting nut but not be less than 2 mm (0.08 in) away from the brake pedal).
- After the pedal height adjustment, make sure that the rear brake does not drag.

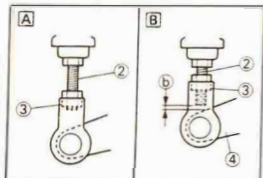

- |  |  |
|--|--|
| <p><b>A</b> Maximum<br/><b>B</b> Minimum</p> | <p>3. Lower adjusting nut<br/>4. Brake pedal<br/>b. 2 mm (0.08 in)</p> |
|--|--|
1. Adjusting nuts
  2. Bolt

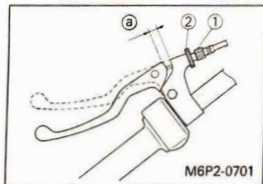

1. Adjuster
2. Locknut
- a. Free play

#### J. Clutch lever free play

1. Check

Free play:  
2-3 mm (0.08-0.12 in)

2. Adjust
  - a. Loosen the locknut.
  - b. Turn the adjuster in or out until the adjustment is suitable.
  - c. Tighten the locknut.

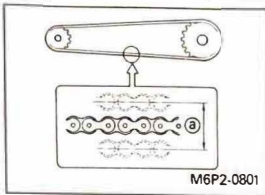

M6P2-0801

a Chain slack

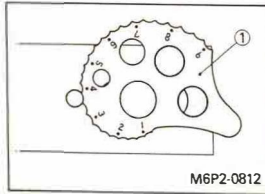

M6P2-0812

1. Chain puller

## K. Drive chain slack

### 1. Check

#### NOTE:

Before checking and/or adjusting, rotate the rear wheel through several revolutions and check the slack several times to find the tightest point. Check and/or adjust chain slack with rear wheel in this "tight chain" position.

- a. Elevate the rear wheel by placing the suitable stand under the engine.
- b. Check the chain slack.

Chain slack (⊖):  
30–35 mm (1.2–1.4 in)

### 2. Adjust

#### CAUTION:

Too small chain slack will overload the engine and other vital parts; keep the slack within the specified limits.

- a. Loosen the rear wheel axle nut.
- b. Turn the both chain puller (Left and right) clockwise or counterclockwise until the specified slack is obtained.

#### NOTE:

Turn each chain puller exactly the same amount to maintain correct axle alignment.

(There are marks on each chain puller; use them to check for proper alignment).

- c. Tighten the axle nut to specification, while pushing up or down the chain to be tight.

Tightening torque:  
115 Nm (11.5 m•kg, 85 ft•lb)



## APPENDICES

### SERVICE DATA

Idling engine speed:	As desired	
Spark plug: Type Gap	B8EG 0.5–0.6 mm (0.020–0.024 in)	
Fuel: Recommended fuel Fuel tank capacity	Premium unleaded fuel with a research octane number of 95 or higher. 13.0 L (2.86 Imp gal, 3.43 US gal)	
Engine oil: Recommended oil, Mixing ratio	<ul style="list-style-type: none"> <li>◦Yamalube Racing 2-cycle oil (24:1)</li> <li>◦Castrol R30 (20:1)</li> <li>◦A747 (20:1)</li> </ul>	
Tire pressure (Cold tire pressure):	Front	Rear
	100 kPa (1.0 kg/cm <sup>2</sup> , 15 psi)	100 kPa (1.0 kg/cm <sup>2</sup> , 15 psi)

[www.legends-yamaha-enduros.com](http://www.legends-yamaha-enduros.com)

Parts to be tightened	Thread size	Tightening torque		
		Nm	m•kg	ft•lb
Handle crown and outer tube	M 8×1.25	23	2.3	17
Under bracket and outer tube	M 8×1.25	20	2.0	14
Handle crown and steering shaft	M36×1.0	115	11.5	85
Handlebar holder (Upper)	M 8×1.25	23	2.3	17
Handlebar holder (Lower)	M10×1.25	40	4.0	29
Steering ring nut (Lower)*1, 2	M28×1.5	4	0.4	2.9
Refer to NOTE				
Front fork and cap bolt	M46×1.0	30	3.0	22
Front fork and base valve	M22×1.0	55	5.5	40
Cap bolt and damper rod (Front fork)	M10×1.0	15	1.5	11
Front fork and hose cover	M 6×1.0	7	0.7	5.1
Front fork and protector	M 6×1.0	7	0.7	5.1
Front brake master cylinder and bracket	M 6×1.0	9	0.9	6.5
Front brake master cylinder cap	M 4×0.7	2	0.2	1.4
Front brake master cylinder and joint bolt	M10×1.25	26	2.6	19
Brake hose (Front and rear) and joint bolt	M10×1.25	14	1.4	10
Front brake hose union bolt (Caliper)	M10×1.25	26	2.6	19
Front brake caliper and axle bracket	M 8×1.25	23	2.3	17
Brake caliper (Front and rear) and pad pin	M10×1.25	18	1.8	13
Brake caliper (Front and rear) and bleed screw	M 8×1.25	6	0.6	4.3
Front wheel axle	M14×1.5	59	5.9	43
Front wheel axle holder	M 6×1.0	9	0.9	6.5
Brake disk (Front and rear) and wheel hub	M 6×1.0	12	1.2	8.7
Rear brake pedal mounting	M 8×1.25	19	1.9	13
Rear brake master cylinder and frame	M 6×1.0	10	1.0	7.2
Rear brake reservoir tank and frame	M 6×1.0	4	0.4	2.9
Rear brake caliper and caliper bracket	M 8×1.25	23	2.3	17
Rear brake caliper and joint bolt	M10×1.25	26	2.6	19
Rear brake hose union bolt (Master cylinder)	M10×1.25	26	2.6	19
Rear wheel axle and nut	M18×1.5	115	11.5	85
Rear wheel sprocket and wheel hub	M 8×1.25	30	3.0	22
Engine mounting:				
Engine and frame (Front)	M 8×1.25	32	3.2	23
Engine and frame (Lower)	M10×1.25	64	6.4	46
Engine bracket (Upper) and frame	M 8×1.25	32	3.2	23
Engine bracket (Upper) and engine	M10×1.25	32	3.2	23

**NOTE:**

- \*1. First, tighten the ring nut approximately 38 Nm (3.8 m•kg, 27 ft•lb) by using the torque wrench, then loosen the ring nut one turn.
- \*2. Retighten the ring nut 4 Nm (0.4 m•kg, 2.9 ft•lb).

Parts to be tightened	Thread size	Tightening torque		
		Nm	m•kg	ft•lb
Pivot shaft and nut	M16×1.5	85	8.5	61
Relay arm and frame	M10×1.25	59	5.9	43
Relay arm and connecting rod	M14×1.5	59	5.9	43
Connecting rod and swingarm	M14×1.5	59	5.9	43
Rear shock absorber and frame	M10×1.25	56	5.6	40
Rear shock absorber and relay arm	M10×1.25	32	3.2	23
Back stay	M 8×1.25	19	1.9	13
Drive chain tensioner mounting	M 8×1.25	19	1.9	13
Seal guard and swingarm	M 6×1.0	5	0.5	3.6
Support chain and protector chain	M 6×1.0	3	0.3	2.2
Protector and swingarm	M 6×1.0	12	1.2	8.7
Fuel tank mounting	M 6×1.0	10	1.0	7.2
Radiator mounting	M 6×1.0	5	0.5	3.6
Radiator and side cover 3, 4	M 5×0.8	4	0.4	2.9
Side cover 3, 4 and fuel tank	M 6×1.0	3	0.3	2.2
Front fender and under bracket	M 6×1.0	6	0.6	4.3
Rear fender mounting	M 6×1.0	7	0.7	5.1
Flap guard mounting	M 6×1.0	5	0.5	3.6
Side cover 1, 2 mounting	M 6×1.0	3	0.3	2.2
Seat mounting	M 8×1.25	16	1.6	11

#### STANDARD EQUIPMENT

No.	Parts name	Q'ty
1	Main jet (#320)	1
2	Main jet (#350)	1
3	Owner's manual	1
4	Owner's tool kit	1

#### OWNER'S TOOL KIT

No.	Part name	Q'ty
1	Spoke wrench	1

[www.legends-yamaha-enduros.com](http://www.legends-yamaha-enduros.com)

[www.legends-yamaha-enduros.com](http://www.legends-yamaha-enduros.com)

**YAMAHA MOTOR CO.,LTD.**

PRINTED IN U.S.A.