



YAMAHA

PARTS CATALOGUE

WR250ZB (3RB3)

WR250Z'91 (3RB3)

ALL

213RB-100E1

www.legends-yamaha-enduros.com

A2



www.legendaryyamahaenduros.com

A3

FOREWORD

This Parts Catalogue is related to the parts in use for the Yamaha WR250ZB/WR250Z'91 (3RB3). When you are ordering replacement parts for the WR250ZB/WR250Z'91 (3RB3), refer to this Parts Catalogue and quote both part numbers and part names correctly.

1. Modifications or additions which have been made after issue of the Parts Catalogue will be announced in the Yamaha Parts News.
It is advisable that according to the Yamaha Parts News you make necessary corrections to the Parts Catalogue on hand to keep it up-to-date.

2. Abbreviations

The following abbreviations are used in this Parts Catalogue.

- U.R. Use size (thickness) and/or number as required.
- U.N. Use as many as you need.
- A.P. Alternate Parts
- L.M. Local Made
- F# Frame No. (Applicable machine No.)

3. The parts marked with (*) in the parts number column of this Catalogue are not supplied with by Yamaha, those have to be found locally.
4. Parts, which are to be supplied in the form of assemblies, are listed with an indention of one letter's space, and a dot (.) is put against the name of each part.

EXAMPLE CARBURETOR ASS'Y
 . JET, pilot
 . NOZZLE, main

5. Indication of No. of constituent parts for assembly

The numeral appearing to the right of each constituent part under the description indicates the quantity of such parts for each individual assembly unit.

EXAMPLE

Part No.	Description	Q'ty	Remarks
2F5-83310-60	FRONT FLASHER LIGHT ASS'Y	2	
115-83311-60	. BULB (6V-18W)	1	
1M1-83309-60	. REFLECTOR	1	

6. Initial Serial No. and Color Code

(A) Frame Serial No.	3RB-012101 and following
(B) Engine Serial No.	3RB-012101 and following

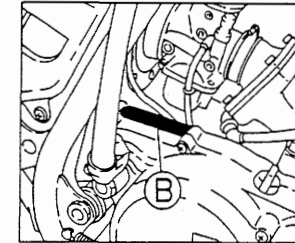
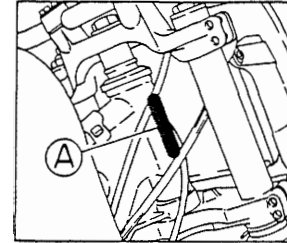

Color Code	Color Name	Abbreviate
0206	PURPLISH WHITE SOLID 1	PWS 1

7. Applicable colors of graphics are represented in the "Remarks" column by the letter(s) appropriately picked out of the full word(s) showing such colors.

EXAMPLE

Part No.	Description	Q'ty	Remarks
2N4-24110-00-X5	FUEL TANK COMP.	1	MAXIM RED
3J1-24240-10	. GRAPHIC, fuel tank set	1	for MXR

www.legends-yamaha-enduros.com

CONTENTS

ENGINE

Cylinder Head	B2 ~ B3
Governor	B4
Crankshaft. Piston	B5
Water Pump	B6
Radiator. Hose	B7
Intake	B8
Carburetor	B9 ~ B10
Exhaust	B11
Crankcase	B12
Crankcase Cover 1	B13
Starter	B14
Clutch	B15
Transmission	C2 ~ C3
Shift Cam. Fork	C4
Shifter	C5

CHASSIS

Frame	C6 ~ C7
Fender	C8
Side Cover	C9 ~ C10
Rear Arm	C11 ~ C12
Rear Suspension	C13
Steering	C14
Front Fork	C15 ~ D3
Fuel Tank	D4
Seat	D5
Front Wheel	D6
Front Brake Caliper	D7
Rear Wheel	D8 ~ D9

Rear Brake Caliper	D10
Steering Handle. Cable	D11
Front Master Cylinder	D12
Stand. Footrest	D13
Rear Master Cylinder	D14
Generator	D15
Handle Switch. Lever	E2
Electrical 1	E3

ALTERNATE PARTS

Alternate (Chassis)	E4
---------------------------	----

REPAIR KIT

Repair Kit	E5
------------------	----

INDEX

Numerical Index	M1 ~ M3
-----------------------	---------

FIG. 1 CYLINDER HEAD

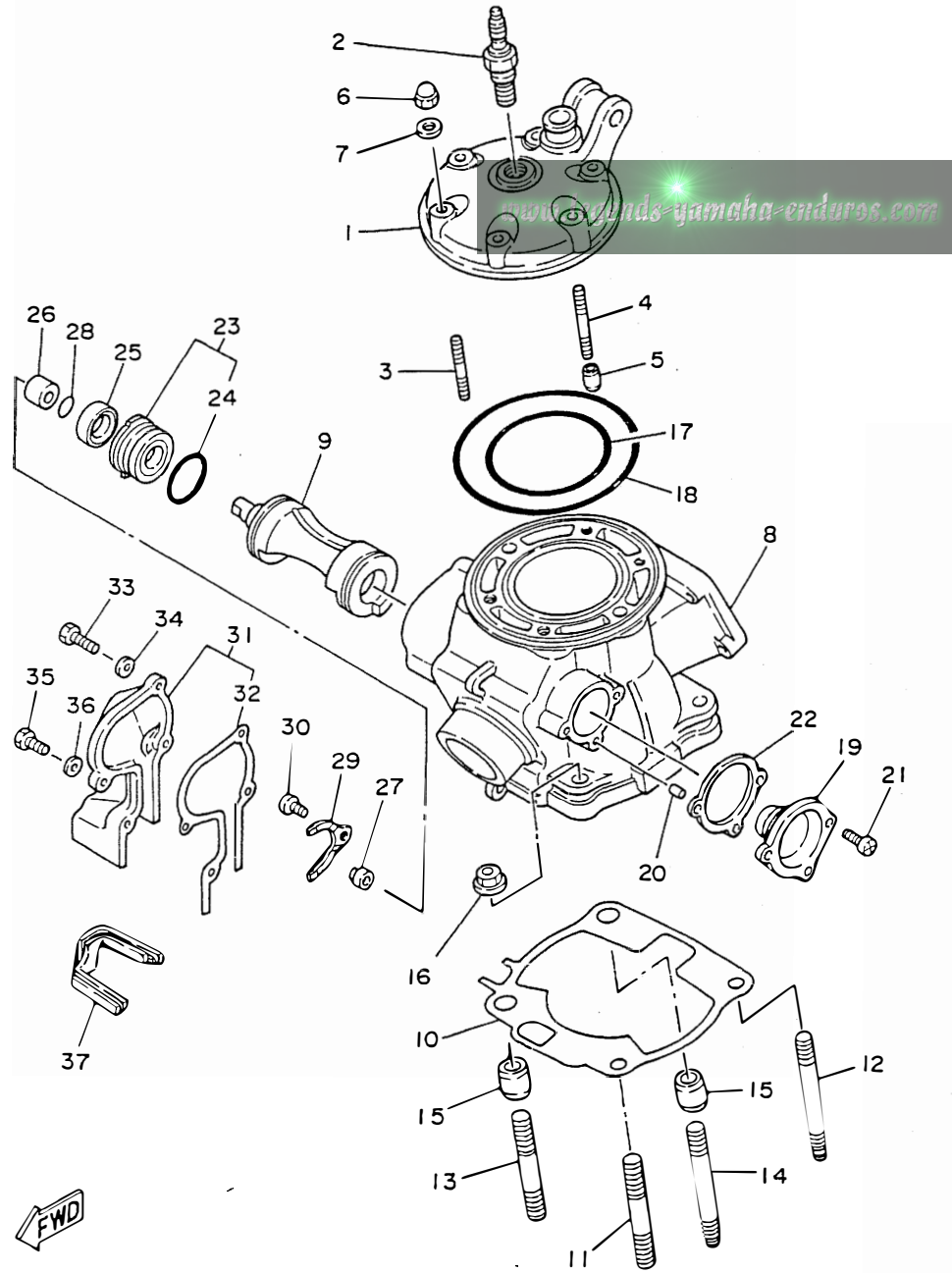

REF. NO.	PART NO.	DESCRIPTION	Q'TY	REMARKS
1	3XK-11111-00	HEAD, cylinder 1	1	
2	94702-00323	PLUG, spark (NGK B8EG)	1	UR
	94702-00326	PLUG, spark (NGK BR8EG)	1	UR FOR CANADA
3	90116-08394	BOLT, stud	4	
4	90116-08392	BOLT, stud	2	
5	99510-10114	PIN, dowel	2	
6	90176-08026	NUT, crown	6	
7	90201-08087	WASHER, plate	6	
8	3XK-11311-00	CYLINDER 1	1	
9	3XK-1131A-00	VALVE 1	1	
10	2VM-11351-10	GASKET, cylinder	1	
11	90116-10314	BOLT, stud	1	
12	90116-10547	BOLT, stud	1	
13	90116-10314	BOLT, stud	1	
14	90116-10547	BOLT, stud	1	
15	99530-14016	PIN, dowel	2	
16	95701-10500	NUT, flange	4	
17	93210-77363	O-RING	1	
18	93211-11770	O-RING	1	
19	3JE-W1132-00	HOLDER 1	1	
20	93604-08071	PIN, dowel	1	
21	98501-05012	SCREW, pan head	2	
22	3JE-1131N-10	GASKET, holder	1	
23	5X4-Y113F-00	HOLDER 2 ASSY	1	
24	93210-270A8	O-RING	1	
25	93104-16074	OIL SEAL	1	
26	90387-102W0	COLLAR	1	
27	3JE-11937-00	BOSS, lever	1	

3SP1100-0010



B2

FIG. 1 CYLINDER HEAD

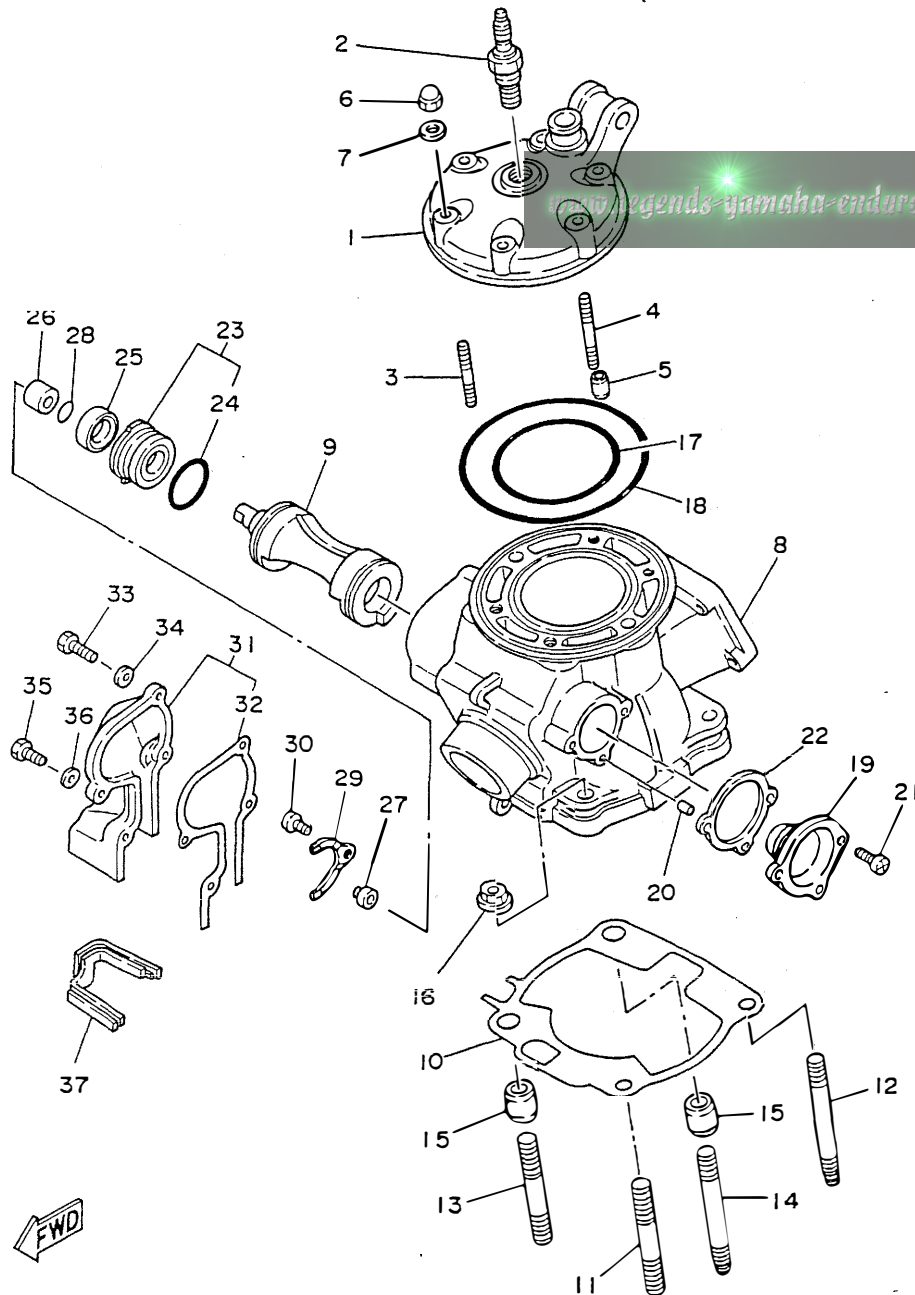

REF. NO.	PART NO.	DESCRIPTION	Q'TY	REMARKS
28	93210-09192	O-RING	1	
29	1LX-11915-00	PLATE, thrust 1	1	
30	98506-05008	SCREW, pan head	1	
31	3SP-11992-10	HOUSING 2	1	
32	3SP-11993-10	.GASKET	1	
33	97021-05020	BOLT	2	
34	92901-05600	WASHER, plate	2	
35	97001-05016	BOLT	2	
36	92901-05600	WASHER, plate	2	
37	2VM-11995-00	SEAL, housing	1	

3SP1100-0010



B3

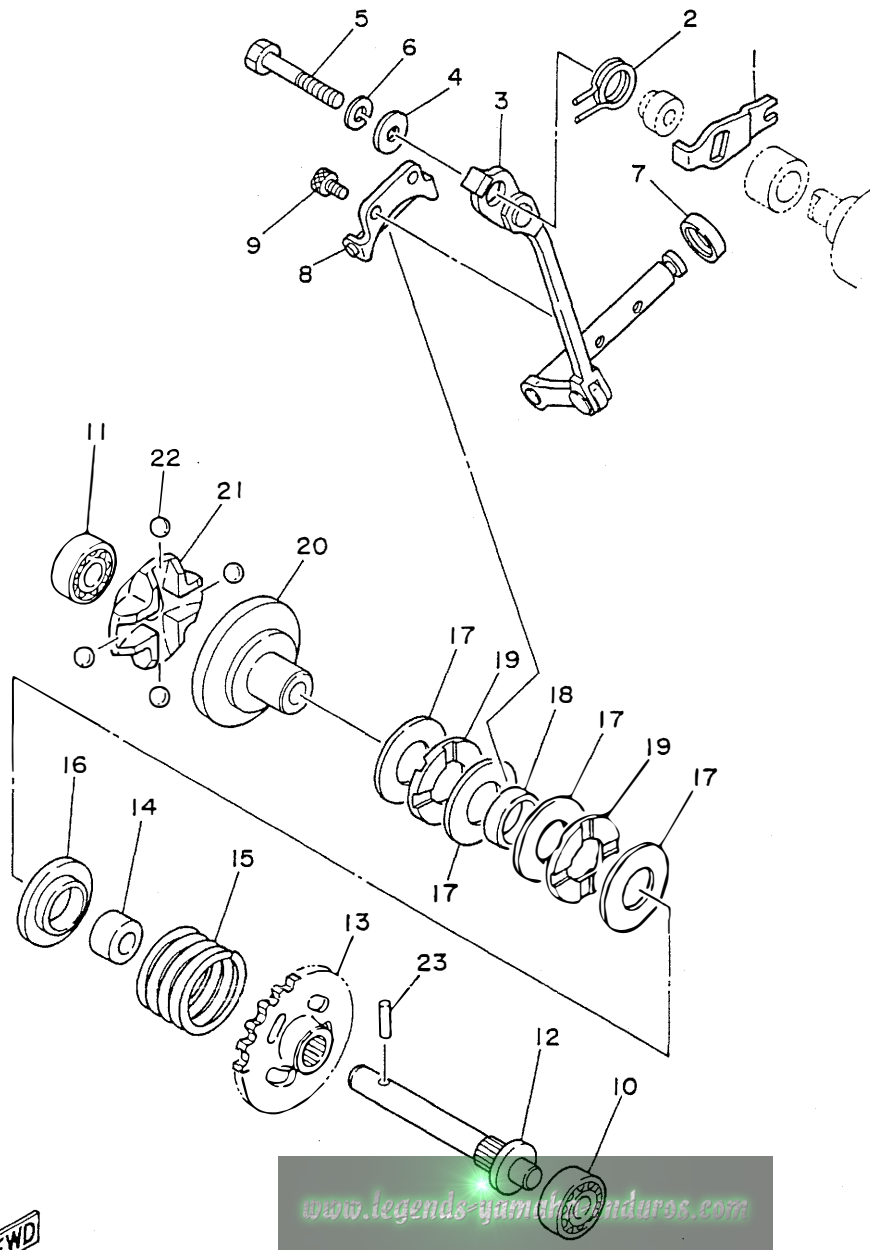

FIG. 2 GOVERNOR

REF. NO.	PART NO.	DESCRIPTION	Q'TY	REMARKS
1	3JE-11931-00	LEVER	1	
2	90508-14783	SPRING, torsion	1	
3	3SP-11990-00	PUSH ROD ASSY	1	
4	90201-057H5	WASHER, plate	1	
5	97021-05030	BOLT	1	
6	92990-05100	WASHER, spring	1	
7	93104-08040	OIL SEAL	1	
8	3JE-11922-00	FORK, governor	1	
9	91316-04006	BOLT	2	
10	93300-60814	BEARING (608M4ML01)	1	NMB
11	93300-60814	BEARING (608M4ML01)	1	NMB
12	5X4-11921-02	SHAFT, governor	1	
13	24X-11953-01	GEAR, governor	1	
14	90560-08213	SPACER	1	
15	90501-240F4	SPRING, compression	1	
16	5X4-11952-00	PLATE	1	
17	90201-154E9	WASHER, plate	4	
18	90387-152F2	COLLAR	1	
19	90380-15104	BUSH, solid	2	
20	5X5-11912-01	RETAINER, weight	1	
21	5X5-11911-01	RETAINER	1	
22	93521-64032	BALL	4	
23	93603-14179	PIN, dowel	1	



3JE1010-9020

B4

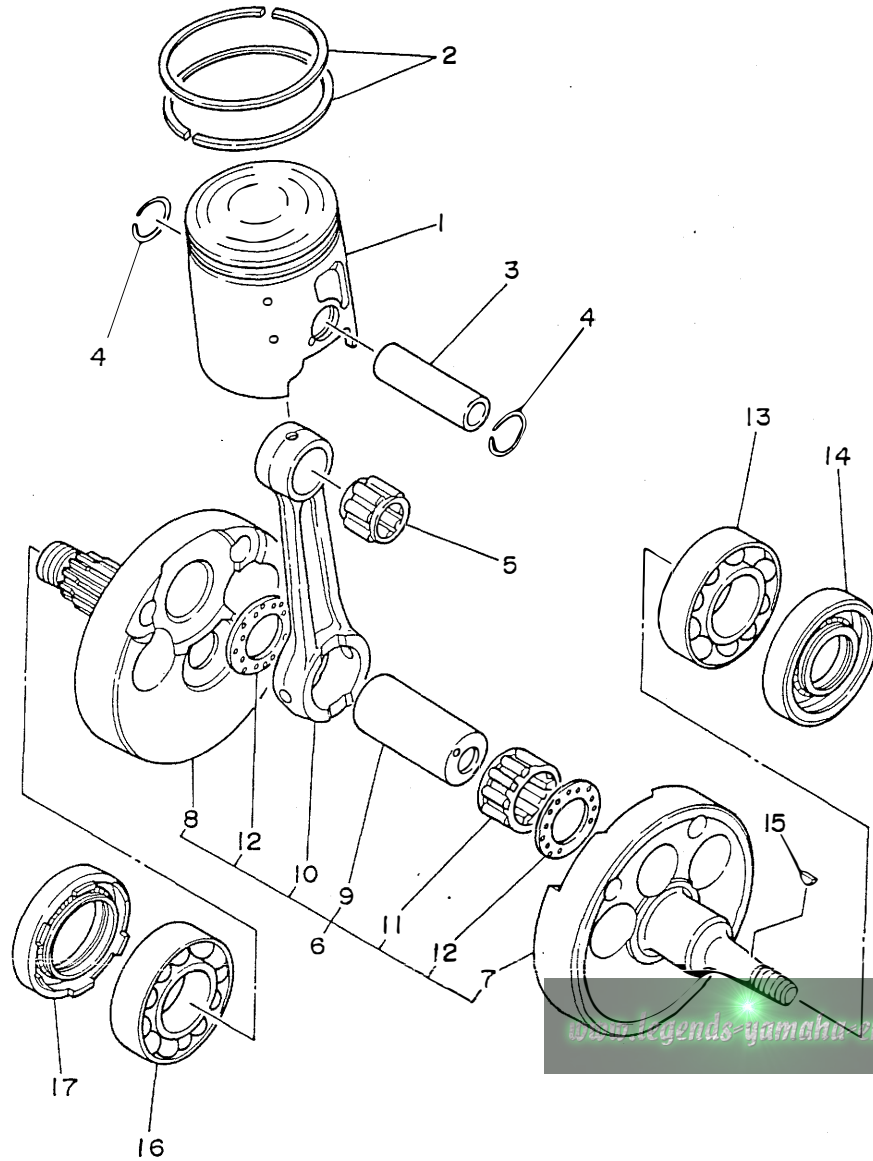

FIG. 3 CRANKSHAFT. PISTON

REF. NO.	PART NO.	DESCRIPTION	Q'TY	REMARKS
1	3XK-11631-00-A0	PISTON (STD)	1	UR RED
	3XK-11631-00-B0	PISTON (STD)	1	UR ORANGE
	3XK-11631-00-C0	PISTON (STD)	1	UR GREEN
	3XK-11631-00-D0	PISTON (STD)	1	UR PURPLE
2	3XK-11601-00	PISTON RING SET (STD)	1	
3	2VM-11633-00	PIN, piston	1	
4	93450-19052	CIRCLIP	2	
5	93310-418E9	BEARING, cylindrical	1	
6	3XK-11400-00	CRANKSHAFT ASSY	1	
7	3XK-11412-00	.CRANK 1	1	
8	3XK-11422-00	.CRANK 2	1	
9	3JE-11681-00	.PIN, crank 1	1	
10	5X5-11651-02	.ROD, connecting	1	
11	93310-425T1	.BEARING, cylindrical	1	
12	90209-25085	.WASHER	2	
13	93306-37802	BEARING	1	
14	93102-22363	OIL SEAL	1	
15	90280-03045	KEY, woodruff	1	
16	93306-37802	BEARING	1	
17	93103-40091	OIL SEAL	1	



3SP1100-0030

B5

FIG. 4 WATER PUMP

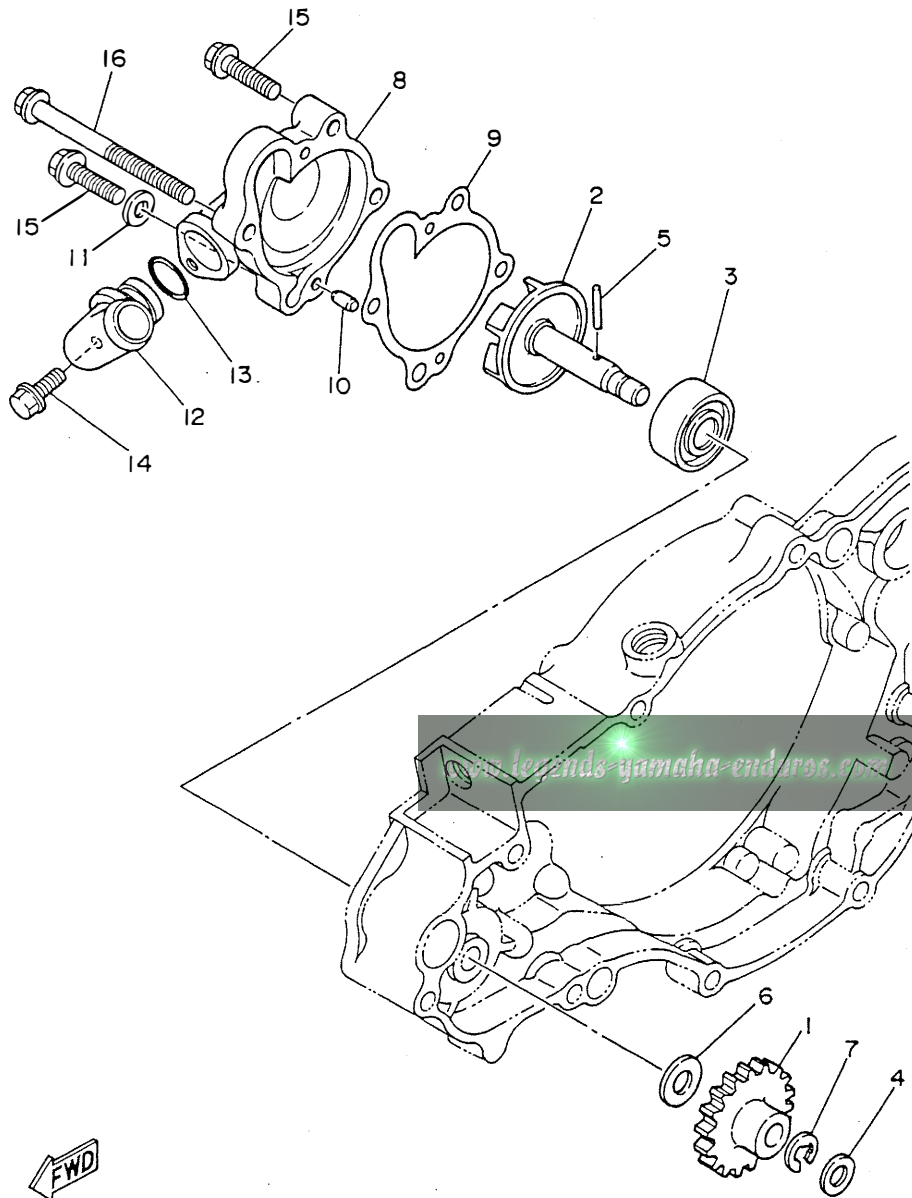

REF. NO.	PART NO.	DESCRIPTION	Q'TY	REMARKS
1	2VM-12459-00	GEAR, impeller shaft	1	
2	2VM-12450-00	IMPELLER SHAFT ASSY	1	
3	93103-10147	OIL SEAL	1	
4	90201-08759	WASHER, plate	1	
5	93603-22028	PIN, dowel	1	
6	90201-08784	WASHER, plate	1	
7	99009-06600	CIRCLIP	1	
8	3SP-12422-00	COVER, housing	1	
9	2VM-12428-10	GASKET, housing cover 2	1	
10	93604-10011	PIN, dowel	2	
11	90430-06166	GASKET	1	
12	10V-12469-01	JOINT 1	1	
13	93210-16275	O-RING	1	
14	95023-06025	BOLT	1	
15	95023-06025	BOLT	3	
16	95021-06080	BOLT, flange	1	



3SP1100-0040

B6

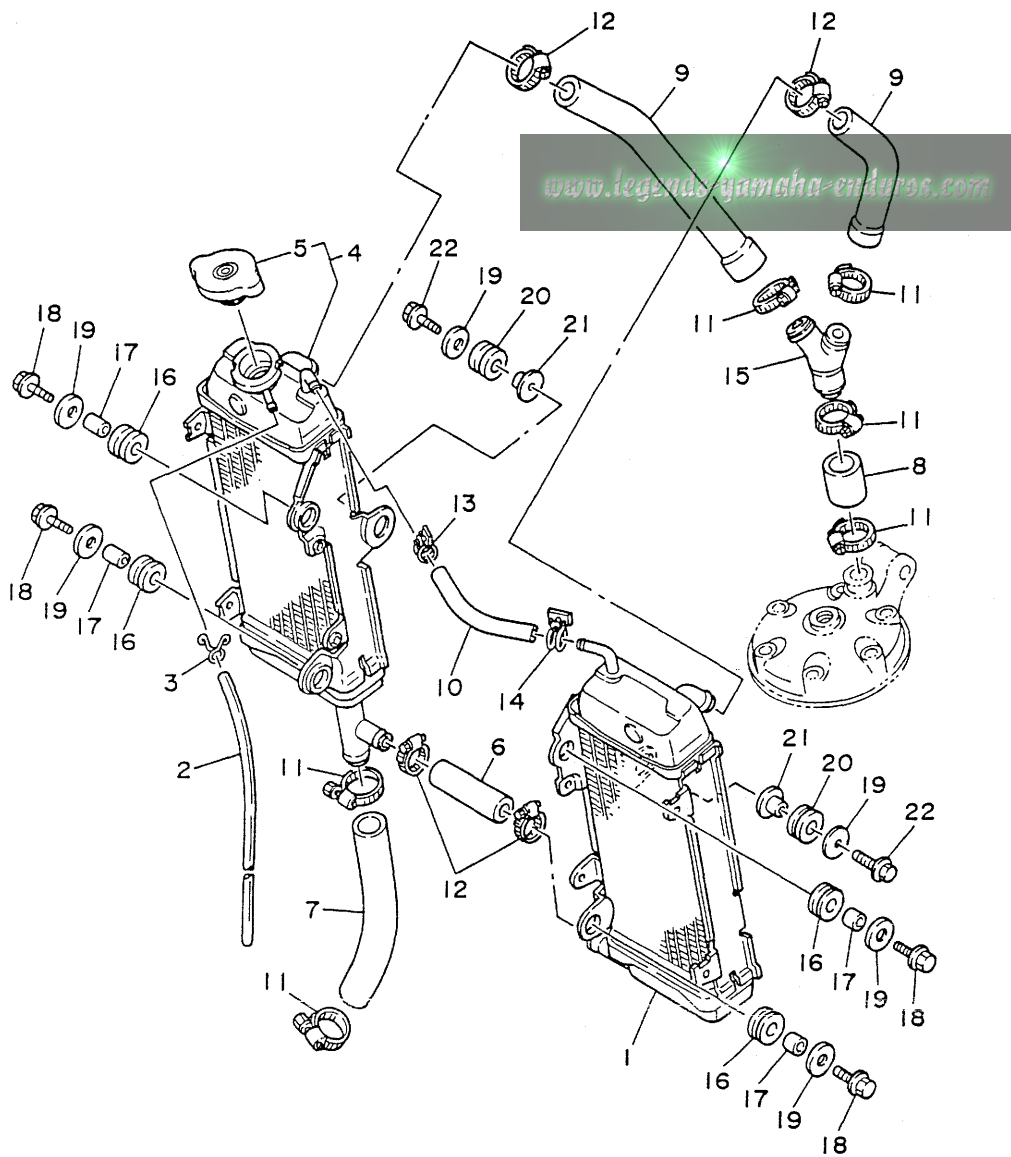

FIG. 5 RADIATOR. HOSE

REF. NO.	PART NO.	DESCRIPTION	Q'TY	REMARKS
1	3SP-12460-00	RADIATOR ASSY	1	
2	90446-09013	HOSE	1	
3	90467-09006	CLIP	1	
4	3SP-1240A-00	RADIATOR ASSY 2	1	
5	22W-12462-00	.CAP, radiator	1	
6	3SP-12482-00	PIPE 2	1	
7	3SP-12483-00	PIPE 3	1	
8	3SP-12485-00	PIPE 5	1	
9	3SP-12476-00	PIPE 6	2	
10	3SP-1248A-00	PIPE 8	1	
11	90450-28014	HOSE CLAMP ASSY	6	
12	90450-22017	HOSE CLAMP ASSY	4	
13	90450-15041	HOSE CLAMP ASSY	1	
14	90450-17036	HOSE CLAMP ASSY	1	
15	24X-12469-00	JOINT 1	1	
16	90480-15528	GROMMET	4	
17	90387-074W0	COLLAR	4	
18	95023-06025	BOLT	4	
19	90201-06570	WASHER, plate	6	
20	90480-18276	GROMMET	2	
21	90387-064W1	COLLAR	2	
22	95023-06020	BOLT	2	



3XK1100-1050

B7

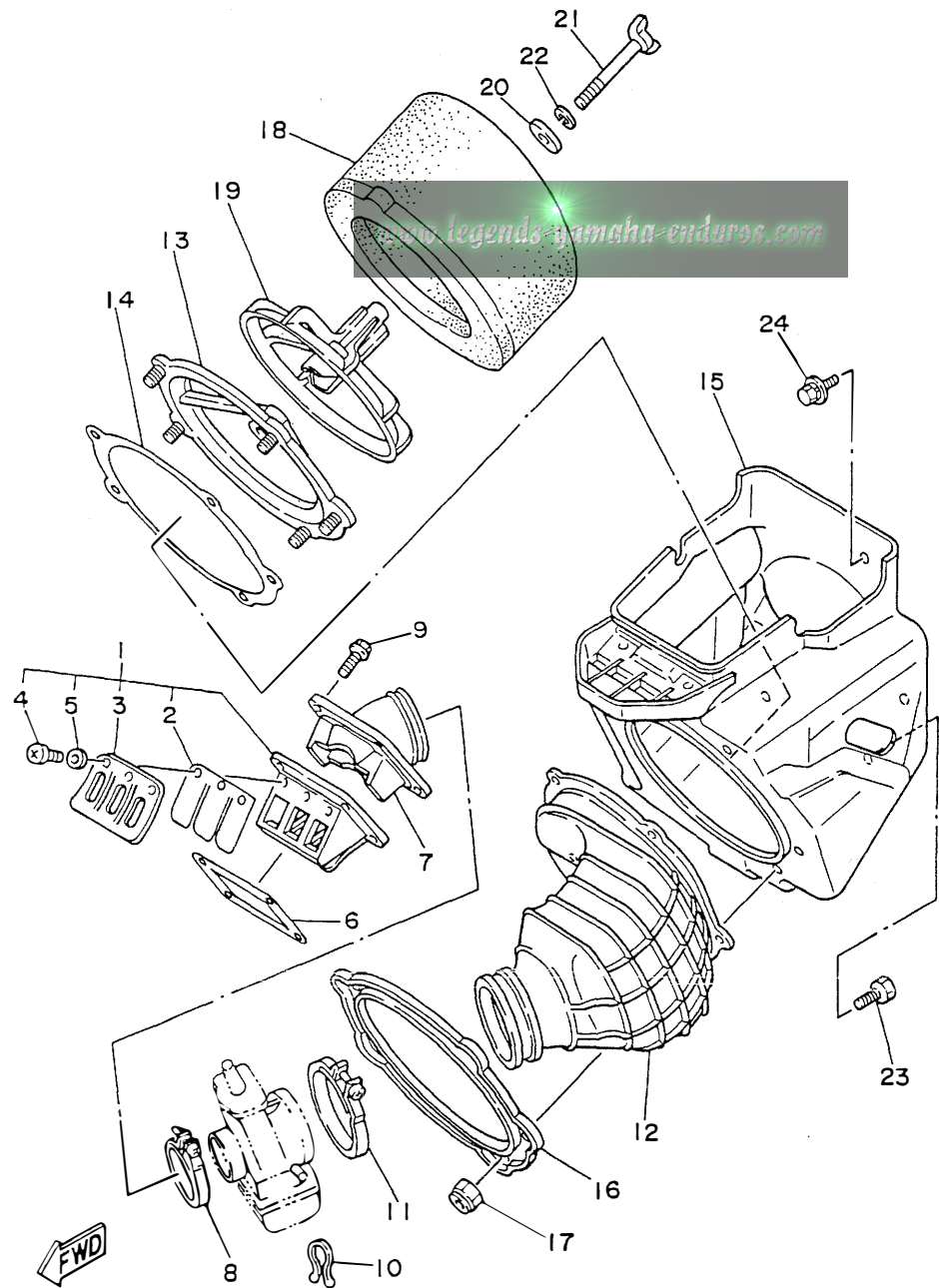

3XK1100-1060

FIG. 6 INTAKE

REF. NO.	PART NO.	DESCRIPTION	Q'TY	REMARKS
1	3SP-13610-00	REED VALVE ASSY	1	
2	3SP-13613-00	.REED, valve	2	
3	3SP-13616-00	.STOPPER, reed valve	2	
4	98580-03008	.SCREW, pan head	6	
5	92990-03100	.WASHER, spring	6	
6	2K7-13621-10	GASKET, valve seat	1	
7	3SP-13565-00	JOINT, carburetor	1	
8	90460-51109	CLAMP, hose	1	
9	95023-06020	BOLT	4	
10	90464-16039	CLAMP	1	
11	90460-68230	CLAMP, hose	1	
12	3XK-14453-00	JOINT, air cleaner 1	1	
13	3JD-14459-00	HOLDER, guide	1	
14	3JD-14462-00	SEAL	1	
15	3XJ-W1441-00	AIR CLEANER CASE COMP.	1	
16	3JD-14477-00	PLATE	1	
17	95601-05100	NUT, u	5	
18	3JD-14451-00	ELEMENT, air cleaner	1	
19	3JD-14458-00	GUIDE	1	
20	90209-06096	WASHER	1	
21	90122-06030	BOLT, wing	1	
22	92990-06100	WASHER, spring	1	
23	95023-06010	BOLT	1	
24	90119-06185	BOLT, with washer	2	

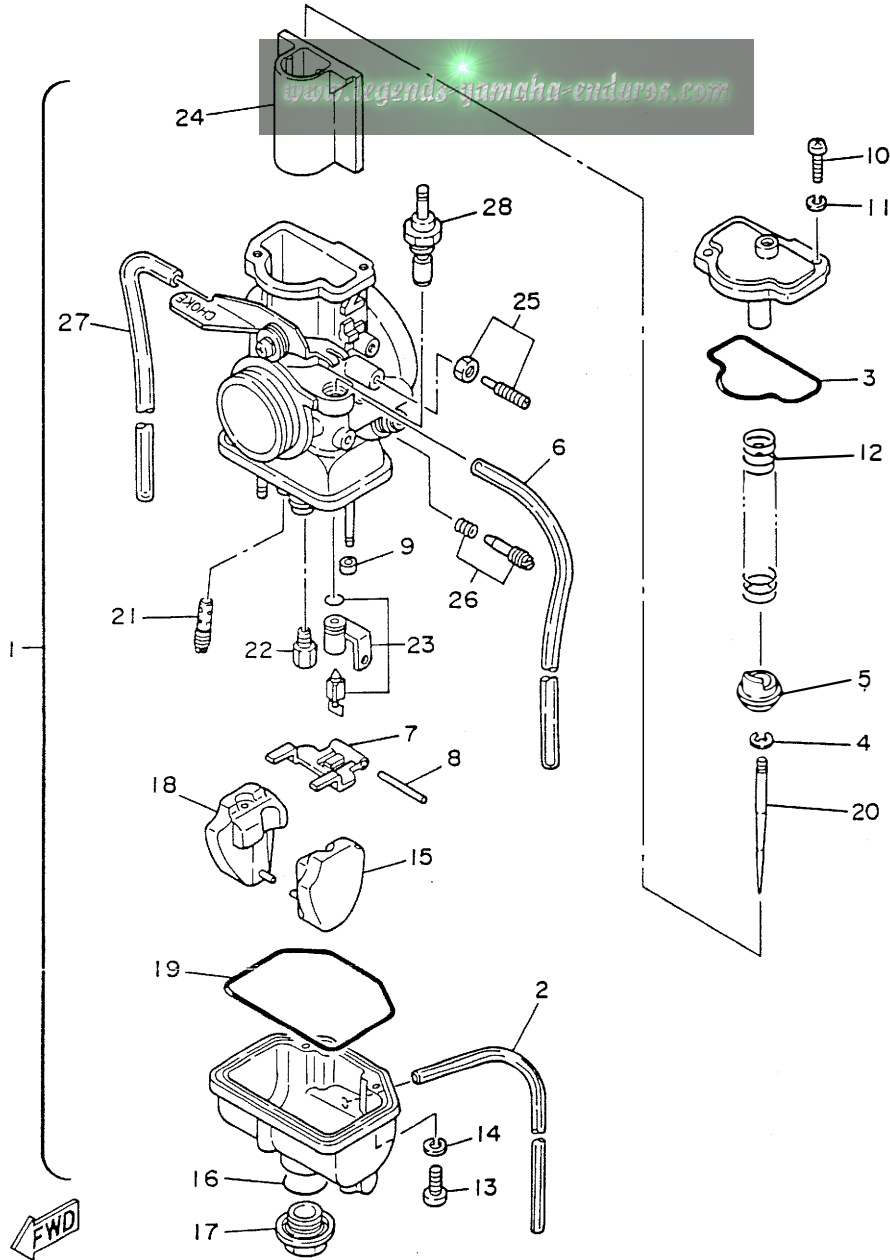

3SP1100-0070

FIG. 7 CARBURETOR

REF. NO.	PART NO.	DESCRIPTION	Q'TY	REMARKS
1	3RB-14101-00	CARBURETOR ASSY 1	1	
2	3X3-14197-00	.PIPE	1	
3	3JD-14147-00	.O-RING	1	
4	256-14919-00	.CLIP	1	
5	3JD-14194-00	.RING	1	
6	3SP-14149-00	.PIPE	1	
7	363-14187-00	.ARM, float	1	
8	353-14186-00	.PIN, float	1	
9	214-14118-00	.CAP	2	
10	98511-04012	.SCREW, pan head	2	
11	92902-04100	.WASHER, spring	2	
12	3JD-14131-00	.SPRING, throttle valve	1	
13	98580-03010	.SCREW, pan head	1	
14	92990-03100	.WASHER, spring	1	
15	3JD-14185-00	.FLOAT	1	
16	3JE-14561-00	.O-RING	1	
17	3XK-14115-00	.PLUG, screw	1	
18	3JE-14185-00	.FLOAT	1	
19	3JE-14147-00	.O-RING	1	
20	275-14116-A6	.NEEDLE (J8-6DJ8-59)	1	STD
	275-14116-E3	.NEEDLE (J8-6DJ8-58)	1	AP
	275-14116-A9	.NEEDLE (J8-6DJ8-60)	1	AP
	275-14116-A7	.NEEDLE (J8-6DJ8-61)	1	AP
	275-14116-E0	.NEEDLE (J8-6DJ8-62)	1	AP
21	3H1-14142-45	.JET, pilot (# 45)	1	STD
	3H1-14142-35	.JET, pilot (# 35)	1	AP
	3H1-14142-40	.JET, pilot (# 40)	1	AP
	3H1-14142-50	.JET, pilot (# 50)	1	AP

B9

FIG. 7 CARBURETOR

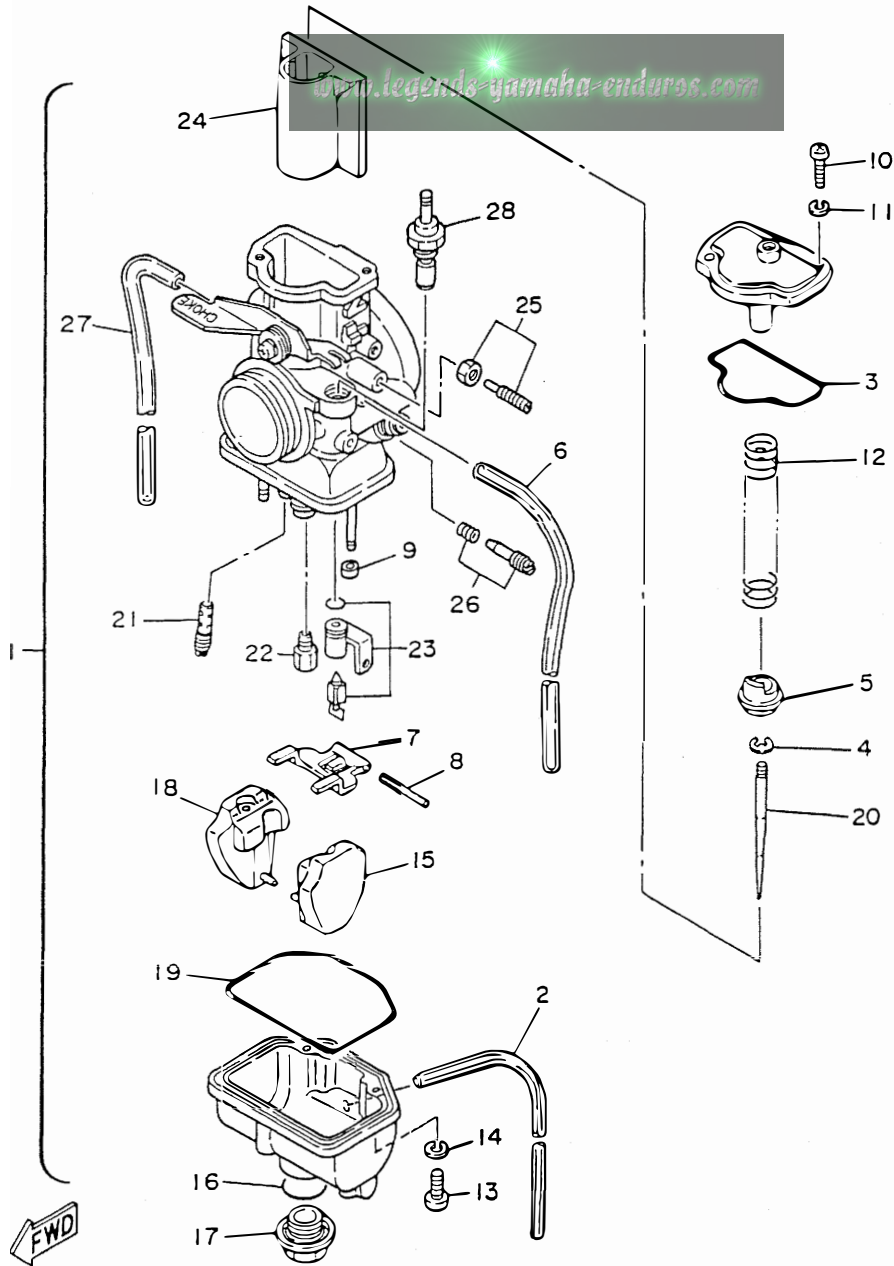

REF. NO.	PART NO.	DESCRIPTION	Q'TY	REMARKS
21	3H1-14142-55	.JET, pilot (# 55)	1	AP
22	137-14143-74	.JET, main (#370)	1	STD
	137-14143-70	.JET, main (#350)	1	AP
	137-14143-72	.JET, main (#360)	1	AP
	137-14143-76	.JET, main (#380)	1	AP
	137-14143-78	.MET, main (#390)	1	AP
23	3JD-14107-35	.NEEDLE VALVE SET	1	
24	3JD-14112-40	.VALVE, throttle (C.A 4.0)	1	STD
	3JD-14112-30	.VALVE, throttle (C.A 3.0)	1	AP
	3JD-14112-35	.VALVE, throttle (C.A 3.5)	1	AP
	3JD-14112-45	.VALVE, throttle (C.A 4.5)	1	AP
	3JD-14112-50	.VALVE, throttle (C.A 5.0)	1	AP
25	3JD-14103-00	.THROTTLE SCREW SET	1	
26	3JD-14104-00	.AIR SCREW SET	1	
27	3SP-14149-00	.PIPE	1	
28	3SP-1410A-00	.STARTER SET	1	

3SP1100-0070

B10

FIG. 8 EXHAUST

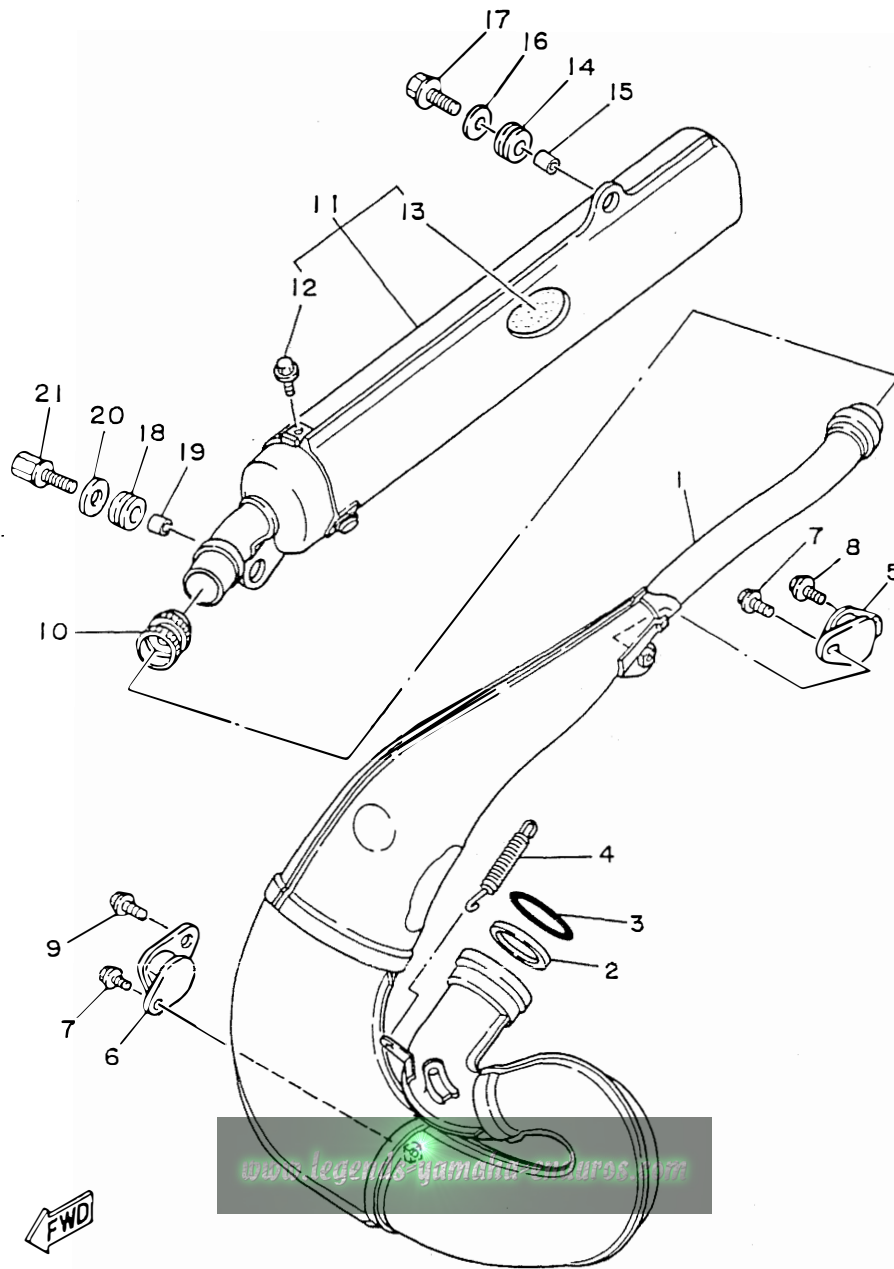

REF. NO.	PART NO.	DESCRIPTION	Q'TY	REMARKS
1	3XK-14610-00	EXHAUST PIPE ASSY 1	1	
2	3R4-14613-00	GASKET, exhaust pipe	1	
3	93210-56743	O-RING	1	
4	90507-20030	SPRING, tension	3	
5	565-14771-00	STAY, muffler 1	1	
6	483-14781-01	STAY, muffler 2	1	
7	95023-06012	BOLT	2	
8	95023-06010	BOLT	1	
9	95023-08012	BOLT	1	
10	3JE-14615-00	JOINT, exhaust 1	1	
11	3XK-14753-10	SILENCER, exhaust	1	
12	95023-06008	.BOLT	3	
13	3XK-1469A-10	.FIBER	1	
14	39X-14747-00	DAMPER, muffler	1	
15	90387-100Y1	COLLAR	1	
16	90201-08612	WASHER, plate	1	
17	95021-08030	BOLT, flange	1	
18	90480-16233	GROMMET	1	
19	90387-060A7	COLLAR	1	
20	90201-06407	WASHER, plate	1	
21	90109-064F4	BOLT	1	



3RB3100-1080

B11

FIG. 9 CRANKCASE

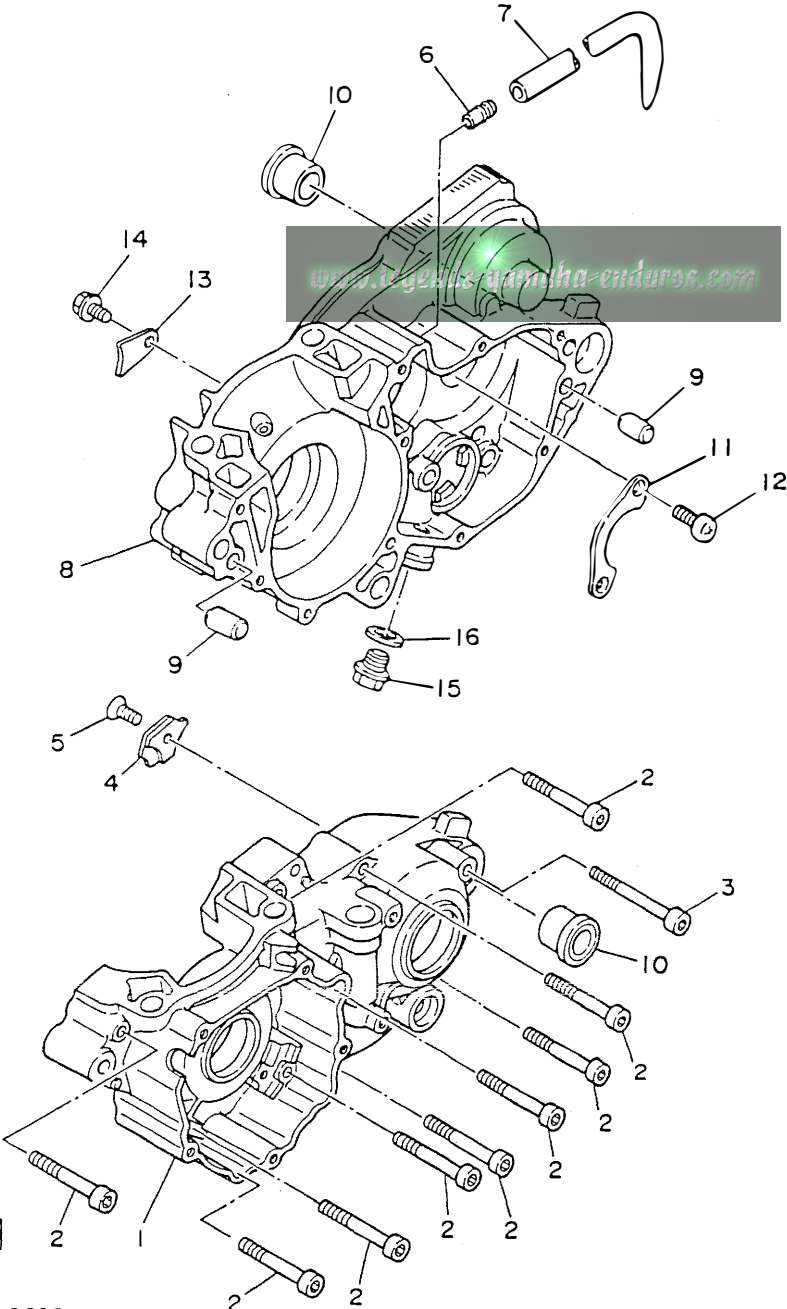

3SP1100-0090

REF. NO.	PART NO.	DESCRIPTION	Q'TY	REMARKS
1	2VM-15111-02	CRANKCASE 1	1	
2	91316-06050	BOLT	9	
3	91316-06070	BOLT	1	
4	3SP-15381-00	PLATE, bearing cover	1	
5	98701-06012	SCREW, flat head	1	
6	353-13115-01	CONNECTOR, suction pipe	1	
7	90445-086A8	HOSE	1	
8	2VM-15121-01	CRANKCASE 2	1	
9	99510-12016	PIN, dowel	2	
10	90387-160H4	COLLAR	2	
11	4L0-17471-00	PLATE, cover	1	
12	98501-06012	SCREW, pan head	2	
13	4V4-15118-00	HOLDER	1	
14	91002-06010	BOLT, flange	1	
15	90340-12097	PLUG, straight screw	1	
16	90430-12207	GASKET	1	

FIG. 10 CRANKCASE COVER 1

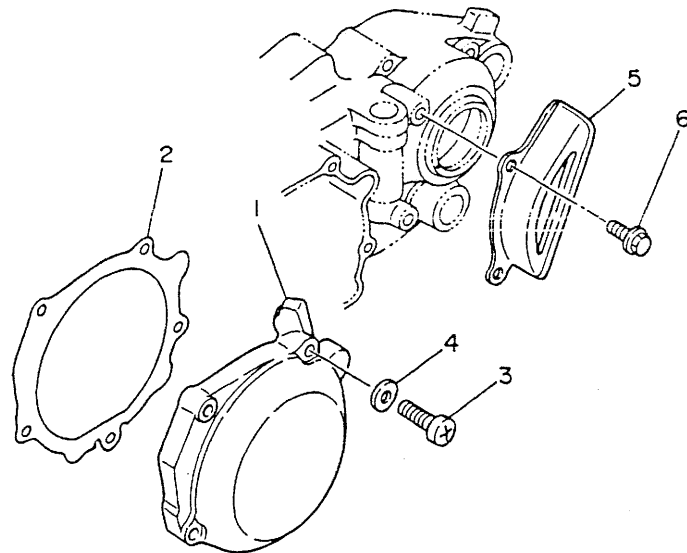
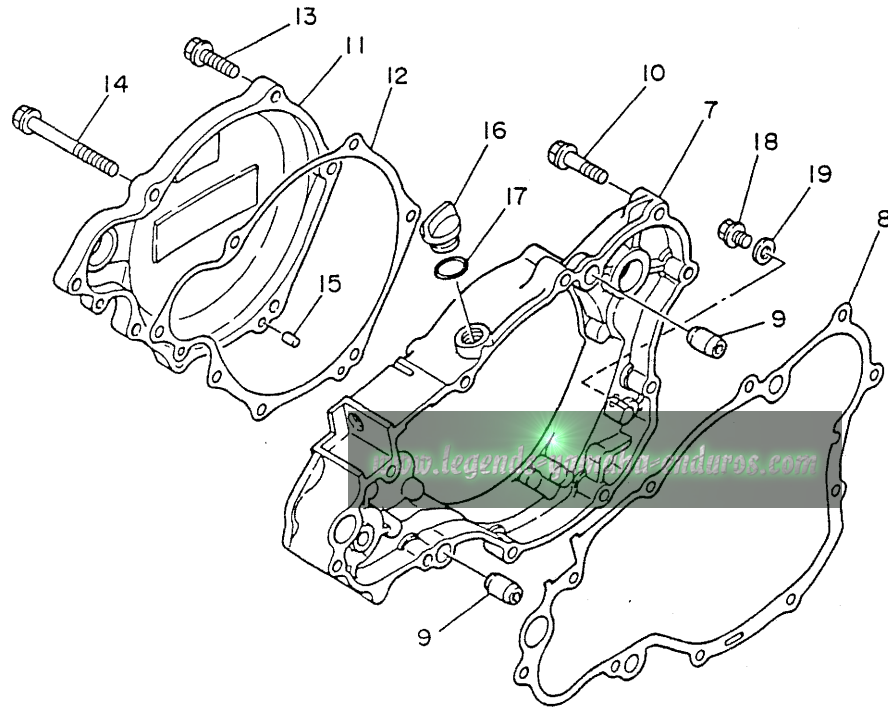

REF. NO.	PART NO.	DESCRIPTION	Q'TY	REMARKS
1	2VM-15411-00	COVER, crankcase 1	1	
2	2VM-15451-10	GASKET, crankcase cover 1	1	
3	98501-06030	SCREW, pan head	5	
4	92901-06600	WASHER, plate	5	
5	2VM-15421-00	COVER, crankcase 2	1	
6	95023-06012	BOLT	2	
7	3SP-Y1543-00	COVER, crankcase 3	1	
8	2VM-15462-10	GASKET, crankcase cover 3	1	
9	99510-12016	PIN, dowel	2	
10	95023-06030	BOLT	7	
11	3SP-15415-00	COVER, generator	1	
12	3SP-15463-10	GASKET, carburetor cover 2	1	
13	95023-06025	BOLT	5	
14	95021-06070	BOLT, flange	2	
15	93604-10011	PIN, dowel	2	
16	1G8-15362-00	PLUG, oil level	1	
17	93210-14104	O-RING	1	
18	95023-06008	BOLT	1	
19	90430-06016	GASKET	1	



3SP1100-0100

B13

FIG. 11 STARTER.

REF. NO.	PART NO.	DESCRIPTION	Q'TY	REMARKS
1	2VM-15661-00	AXLE, kick	1	
2	3R4-15641-00	GEAR, kick (26T)	1	
3	90468-26048	CLIP	1	
4	90201-20358	WASHER, plate	1	
5	90508-30743	SPRING, torsion	1	
6	2VM-15664-00	GUIDE, spring	1	
7	38V-15651-00	GEAR, kick idle (23T)	1	
8	90201-17545	WASHER, plate	2	
9	99009-17400	CIRCLIP	1	
10	93102-20309	OIL SEAL	1	
11	3SP-15620-00	KICK CRANK ASSY	1	
12	3SP-15621-00	.BOSS, kick crank	1	
13	93501-04011	.BALL	1	
14	90501-13720	.SPRING, compression	1	
15	93210-19216	.O-RING	1	
16	90157-06048	.SCREW, pan head	1	
17	95023-08020	BOLT	1	
18	90201-087A9	WASHER, plate	1	

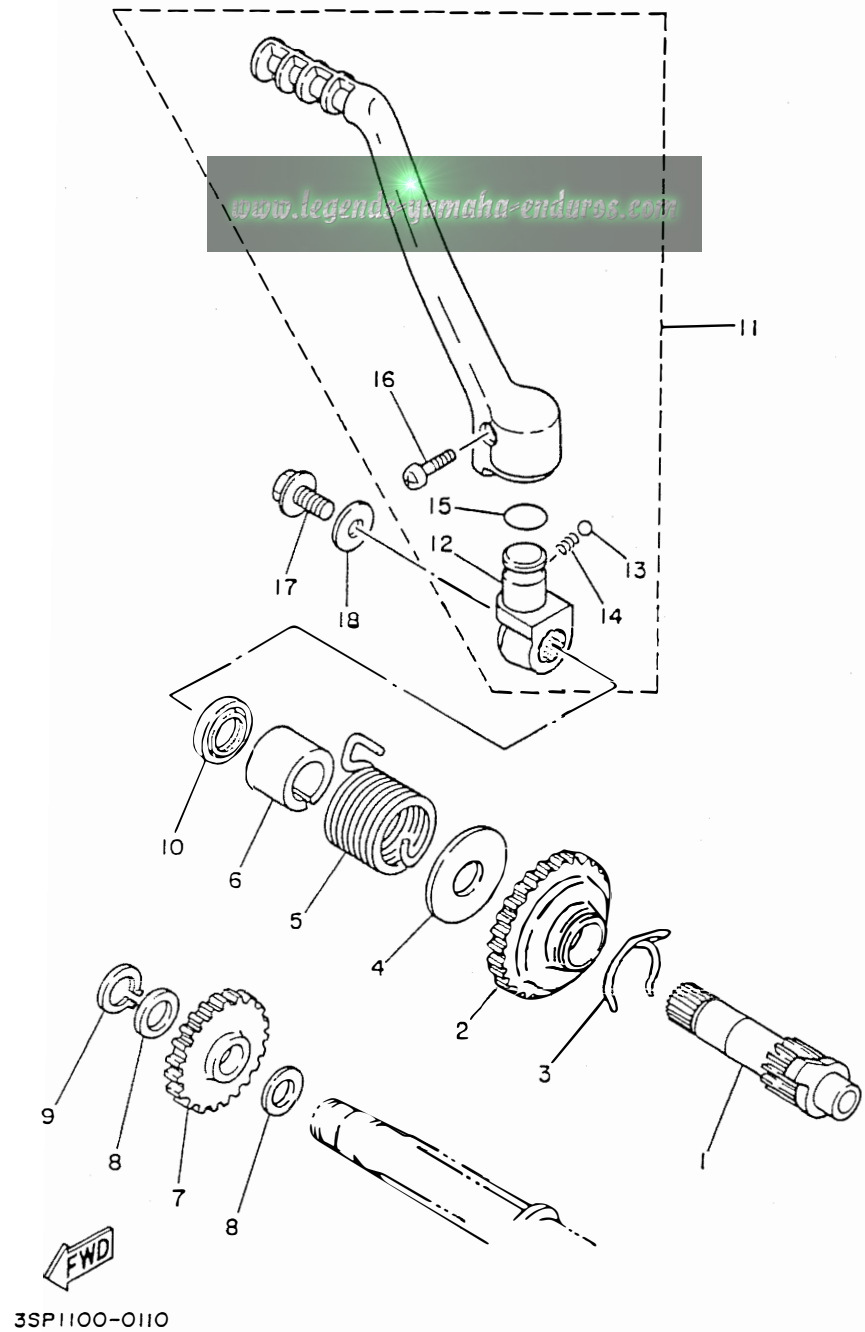

3SP1100-0110

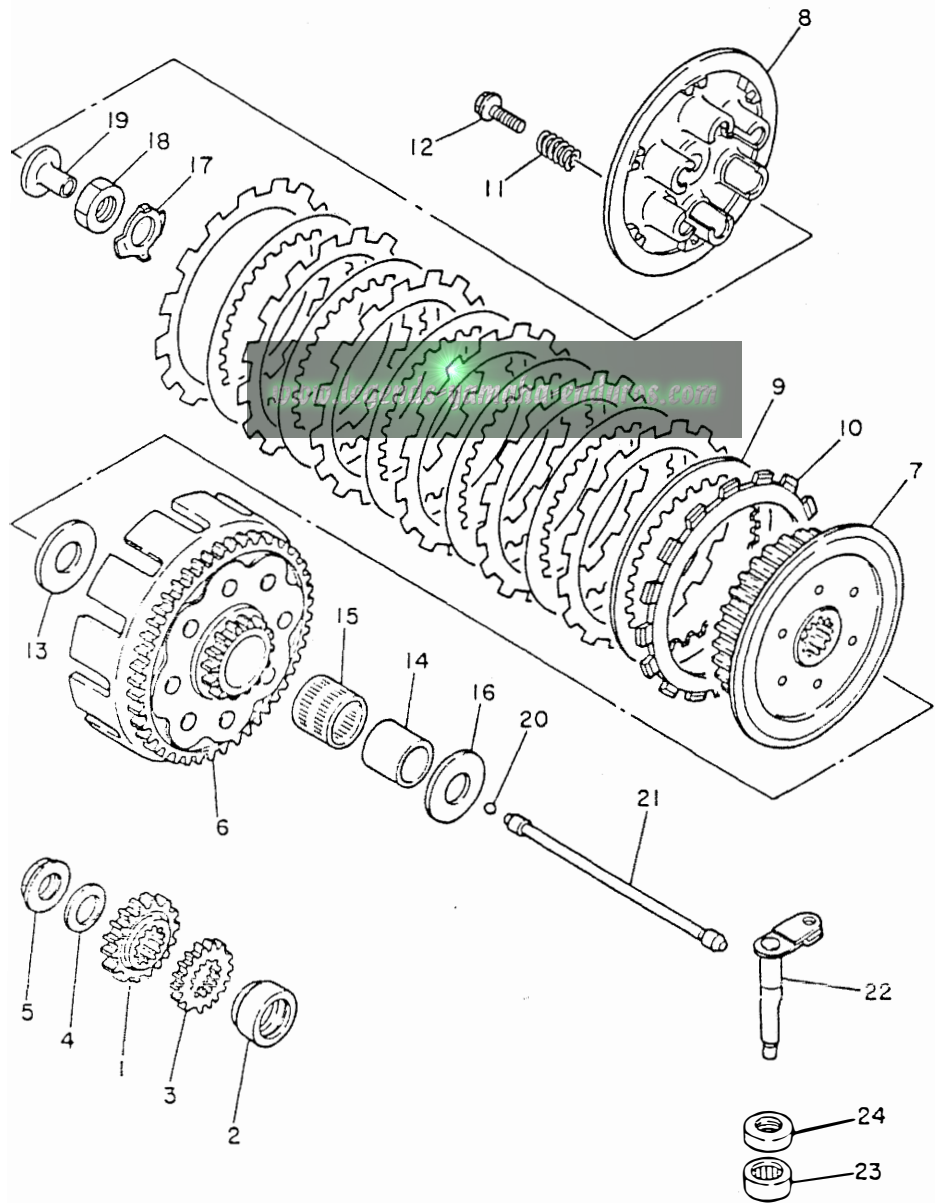

FIG. 12 CLUTCH

REF. NO.	PART NO.	DESCRIPTION	Q'TY	REMARKS
1	2VM-16111-00	GEAR, primary drive	1	
2	90387-252F6	COLLAR	1	
3	3XK-11956-00	GEAR, governor drive	1	
4	90208-18025	WASHER, conical spring	1	
5	90179-18172	NUT	1	
6	3SP-16150-00	PRIMARY DRIVEN GEAR COMP.	1	
7	2VM-16371-00	BOSS, clutch	1	
8	2VM-16351-00	PLATE, pressure 1	1	
9	3XK-16325-00	PLATE, clutch 2	6	
10	3XK-16321-00	PLATE, friction	7	
11	90501-23598	SPRING, compression	6	
12	90159-06016	SCREW, with washer	6	
13	2K7-16154-00	PLATE, thrust 1	1	
14	2VM-16181-00	SPACER 1	1	
15	93310-230T7	BEARING, cylindrical	1	
16	3SP-16154-00	PLATE, thrust 1	1	
17	90215-20231	WASHER, lock	1	
18	90170-20255	NUT	1	
19	2VM-16356-00	ROD, push 1	1	
20	93511-32027	BALL	1	
21	3SP-16357-00	ROD, push 2	1	
22	2VM-16381-00	PUSH LEVER COMP.	1	
23	93315-11206	BEARING, cylindrical	1	
24	93102-12224	OIL SEAL	1	



2VM100-8120

B15

FIG. 13 TRANSMISSION

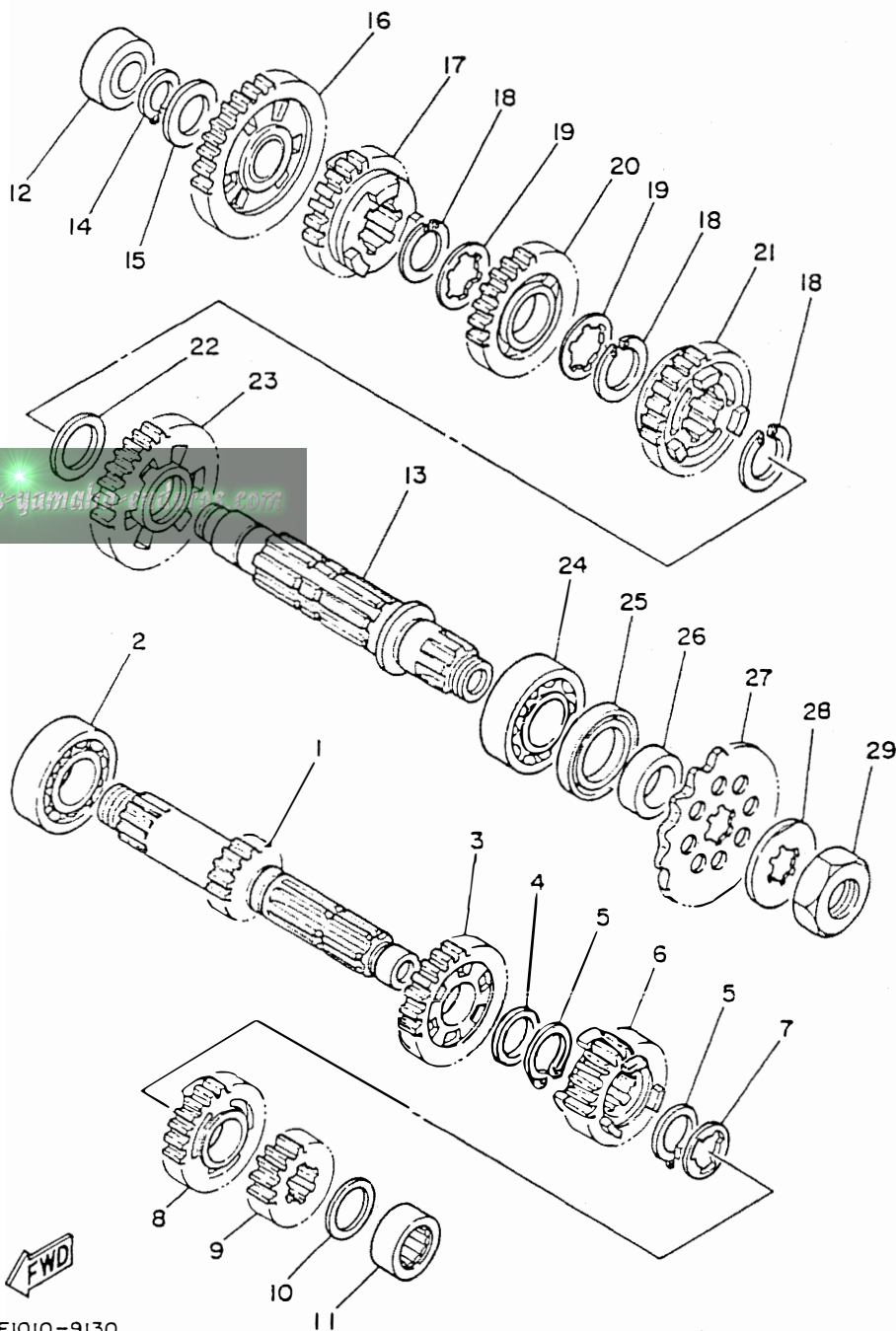

REF. NO.	PART NO.	DESCRIPTION	Q'TY	REMARKS
1	3RB-17411-00	AXLE, main (14T)	1	
2	93306-20540	BEARING	1	
3	3RB-17151-00	GEAR, 5th pinion (25T)	1	
4	90201-22555	WASHER, plate	1	
5	93410-22039	CIRCLIP	2	
6	3RB-17131-00	GEAR, 3rd pinion	1	
7	90209-18135	WASHER	1	
8	3RB-17141-10	GEAR, 4th pinion	1	
9	2VM-17121-00	GAER, 2nd pinion (17T)	1	
10	90209-17311	WASHER	1	
11	93311-41734	BEARING, cylindrical	1	
12	93311-62035	BEARING, cylindrical	1	
13	2VM-17421-00	AXLE, drive	1	
14	93410-20038	CIRCLIP	1	
15	90201-20278	WASHER, plate	1	
16	3RB-17211-00	GEAR, 1st wheel (32T)	1	
17	3RB-17251-00	GEAR, 5th wheel (21T)	1	
18	93440-25084	CIRCLIP	3	
19	90209-22082	WASHER	2	
20	3RB-17231-00	GEAR, 3rd wheel	1	
21	3RB-17241-10	GEAR, 4th wheel	1	
22	90201-253K0	WASHER, plate (T=1.0)	1	
23	2VM-17221-00	GEAR, 2nd wheel (29T)	1	
24	93306-20574	BEARING	1	
25	93102-32M07	OIL SEAL	1	
26	90387-25663	COLLAR	1	
27	93834-14049	SPROCKET,drive 14T (1W41746140)	1	STD
	93834-13029	SPROCKET,drive 13T (1W41746130)	1	AP

3JE1010-9130

FIG. 13 TRANSMISSION

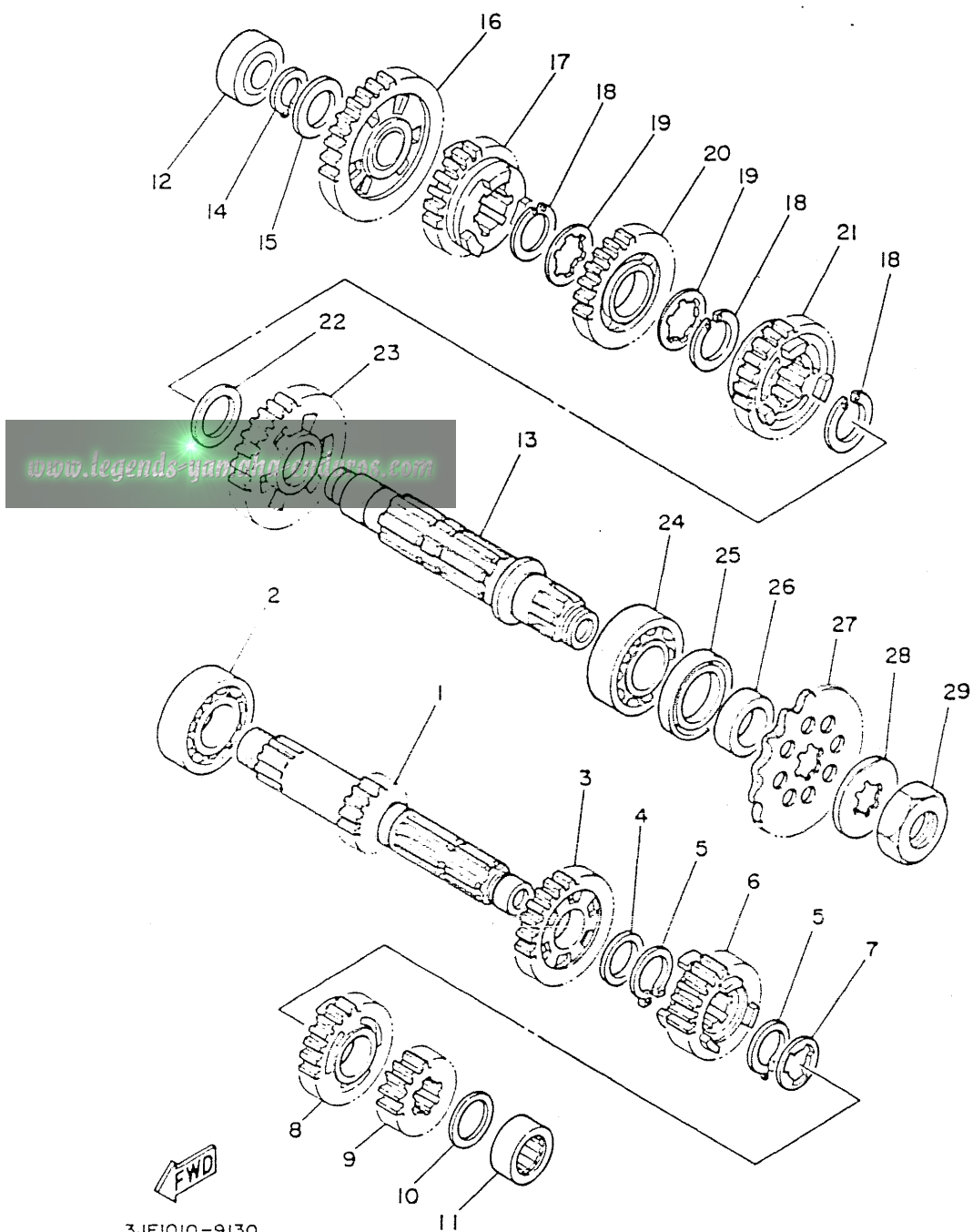

REF. NO.	PART NO.	DESCRIPTION	Q'TY	REMARKS
27	93834-15075	SPROCKET,drive 15T (1W41746150)	1	AP
28	90215-21239	WASHER, lock	1	
29	90179-20255	NUT	1	

3JE1010-9130

C3

FIG. 14 SHIFT CAM. FORK

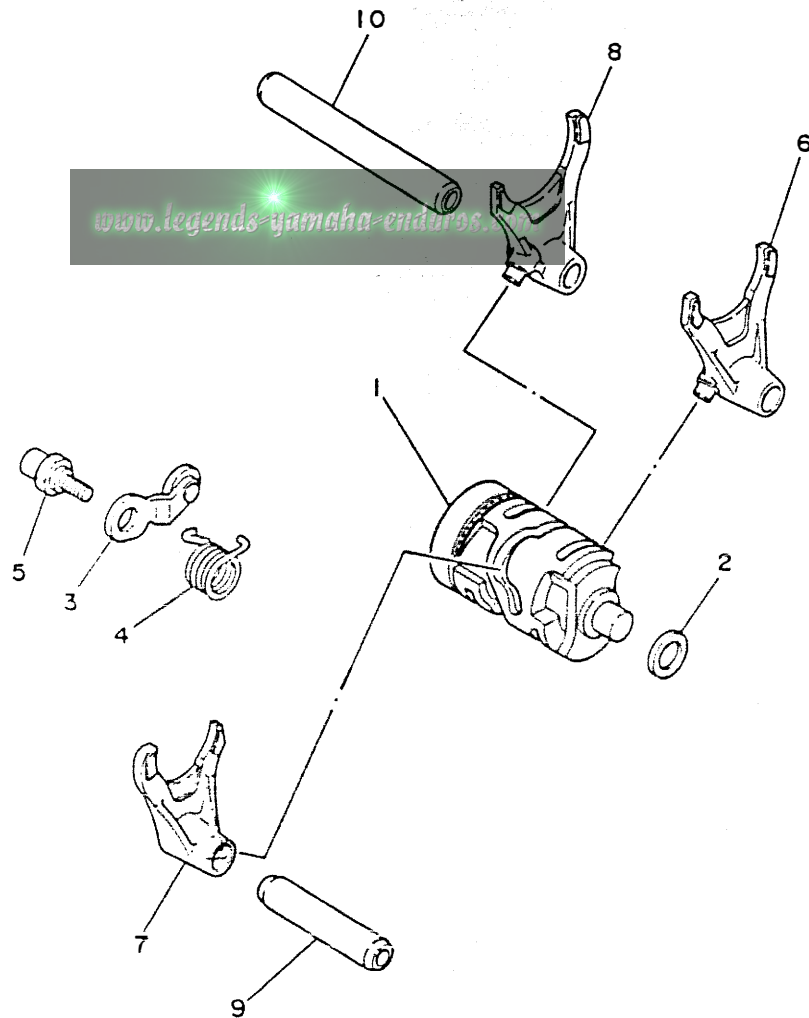

REF. NO.	PART NO.	DESCRIPTION	Q'TY	REMARKS
1	3XK-18540-00	SHIFT CAM ASSY	1	
2	90201-12166	WASHER, plate	1	
3	3XK-18140-00	STOPPER LEVER ASSY	1	
4	90508-26561	SPRING, torsion	1	
5	3XK-18177-00	BOLT, stopper	1	
6	2VM-18511-00	FORK, shift 1	1	
7	2VM-18512-00	FORK, shift 2	1	
8	2VM-18513-00	FORK, shift 3	1	
9	1LX-18531-00	BAR, shift fork guide 1	1	
10	34K-18535-00	BAR, shift fork guide 2	1	



3XK1100-1140

C4

FIG. 15 SHIFTER

REF. NO.	PART NO.	DESCRIPTION	Q'TY	REMARKS
1	3XK-18101-00	SHIFT SHAFT ASSY	1	
2	3XK-18122-00	LEVER, shift 2	1	
3	90560-12171	SPACER	1	
4	90508-29742	SPRING, torsion	1	
5	93608-33046	PIN, dowel	1	
6	2VM-18110-00	SHIFT PEDAL ASSY	1	
7	98021-06025	BOLT	1	
8	93102-12106	OIL SEAL SD 10-22-# 15	1	
9	3XJ-18173-00	PIN, shift	1	
10	3XJ-18178-00	ROLLER, shift lever	1	
11	3XJ-18182-00	PAW, shifter	1	
12	90501-05265	SPRING, compression	1	
13	3XJ-18184-00	PIN, pawl	1	
14	3XK-18172-00	GUIDE, shift	1	
15	90101-06664	BOLT	1	
16	3XJ-18185-00	SEGMENT	1	

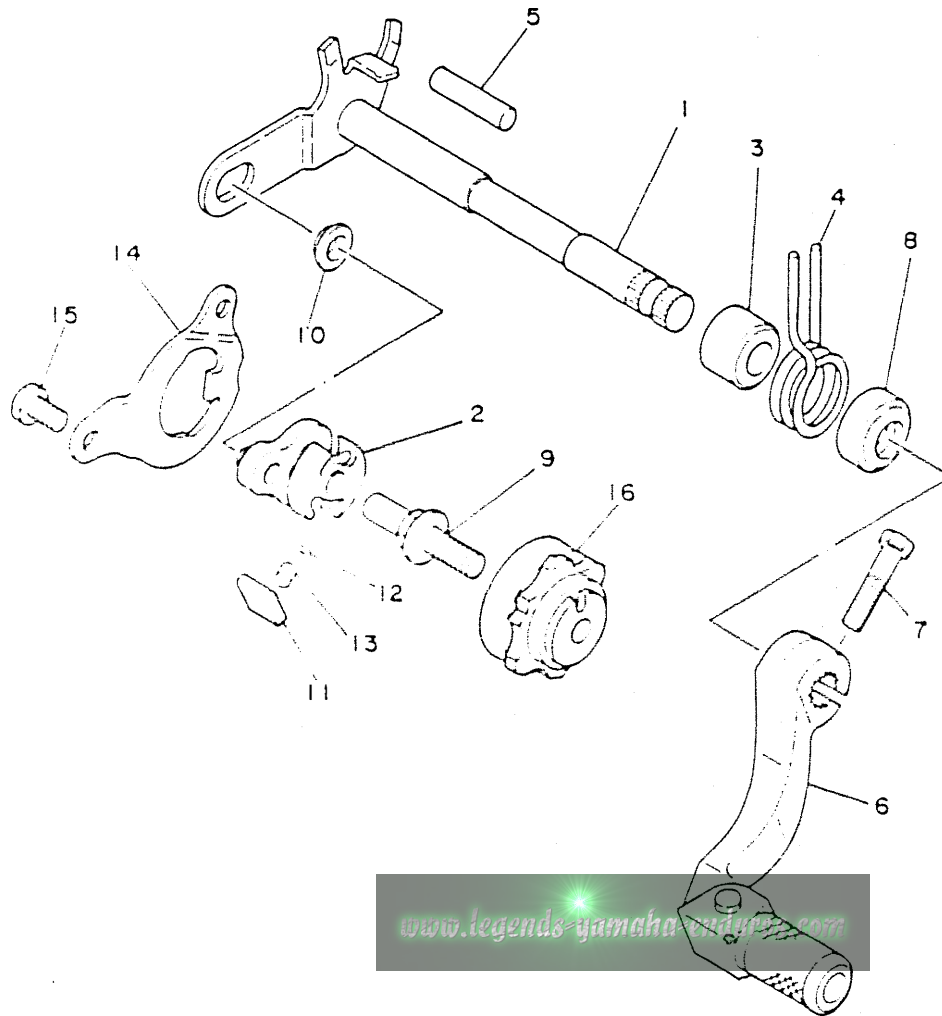

3XK1100-1150

C5

FIG. 16 FRAME

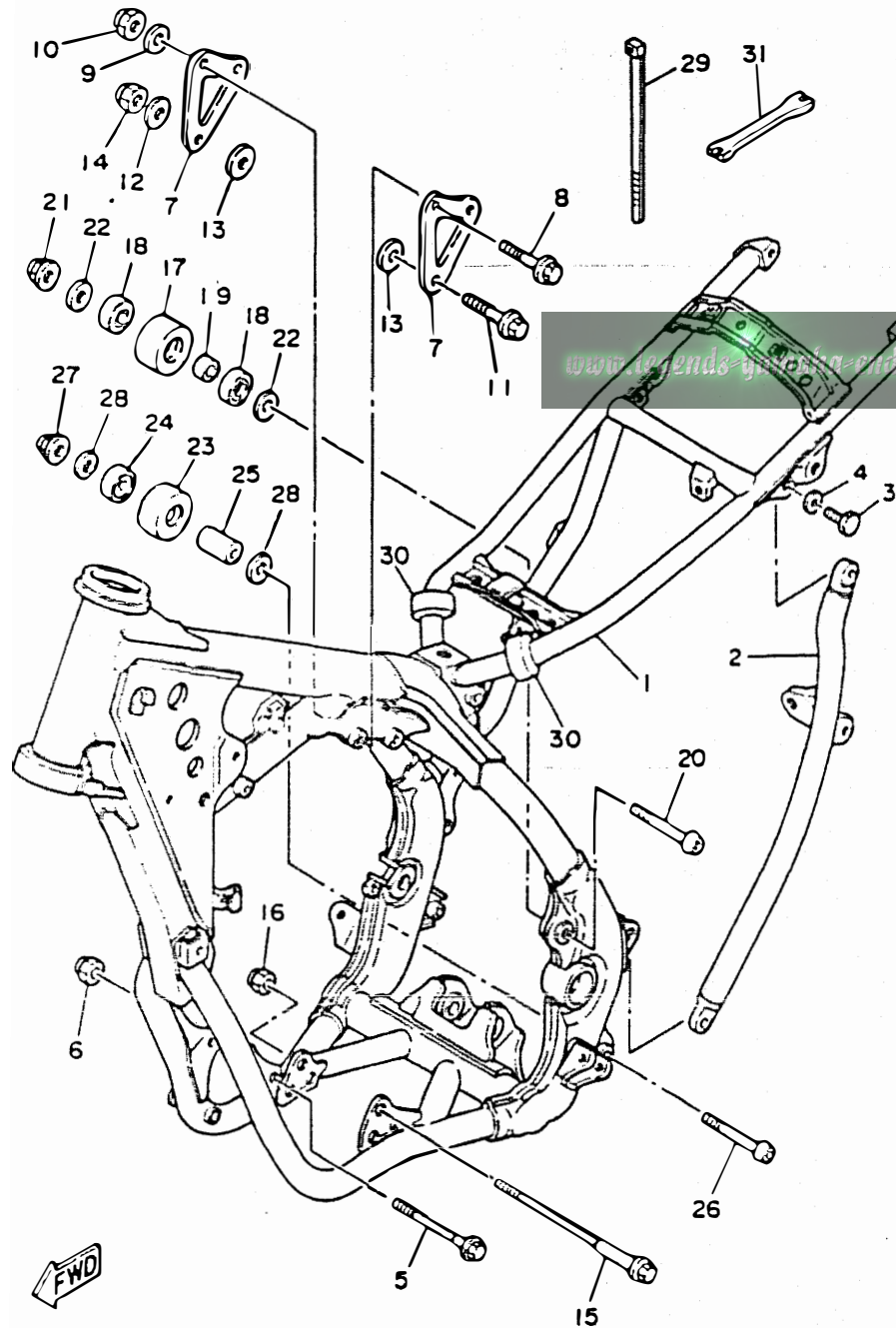

3XK1100-1160

REF. NO.	PART NO.	DESCRIPTION	Q'TY	REMARKS
1	3XK-21110-00-UJ	FRAME COMP.	1	RADICAL WHITE
2	3XK-21123-00-UJ	BACK, stay lh.	1	RADICAL WHITE
3	90101-08461	BOLT	2	
4	90201-080E2	WASHER, plate	2	
5	90105-08592	BOLT, washer based	1	
6	95611-08200	NUT, self-locking	1	
7	3SP-21425-00	BRACKET, rear upper 1	2	
8	91011-08055	BOLT, flange	2	
9	90202-08022	WASHER, plate	2	
10	95601-08200	NUT, self-locking	2	
11	91011-10055	BOLT, flange	1	
12	92990-10200	WASHER, plain	1	
13	90201-101J1	WASHER, plate	2	
14	95601-10200	NUT, self-locking	1	
15	91011-10120	BOLT, flange	1	
16	95611-10200	NUT, self-locking	1	
17	3JD-22178-00	TENSIONER	1	
18	93300-60816	BEARING	2	
19	90387-087K5	COLLAR	1	
20	92011-08070	SCREW	1	
21	95601-08200	NUT, self-locking	1	
22	90201-081A6	WASHER, plate	2	
23	3JD-22178-10	TENSIONER	1	
24	93300-60816	BEARING	1	
25	90387-086N4	COLLAR	1	
26	92011-08070	SCREW	1	
27	95601-08200	NUT, self-locking	1	
28	90201-081A6	WASHER, plate	2	

C6

FIG. 16 FRAME

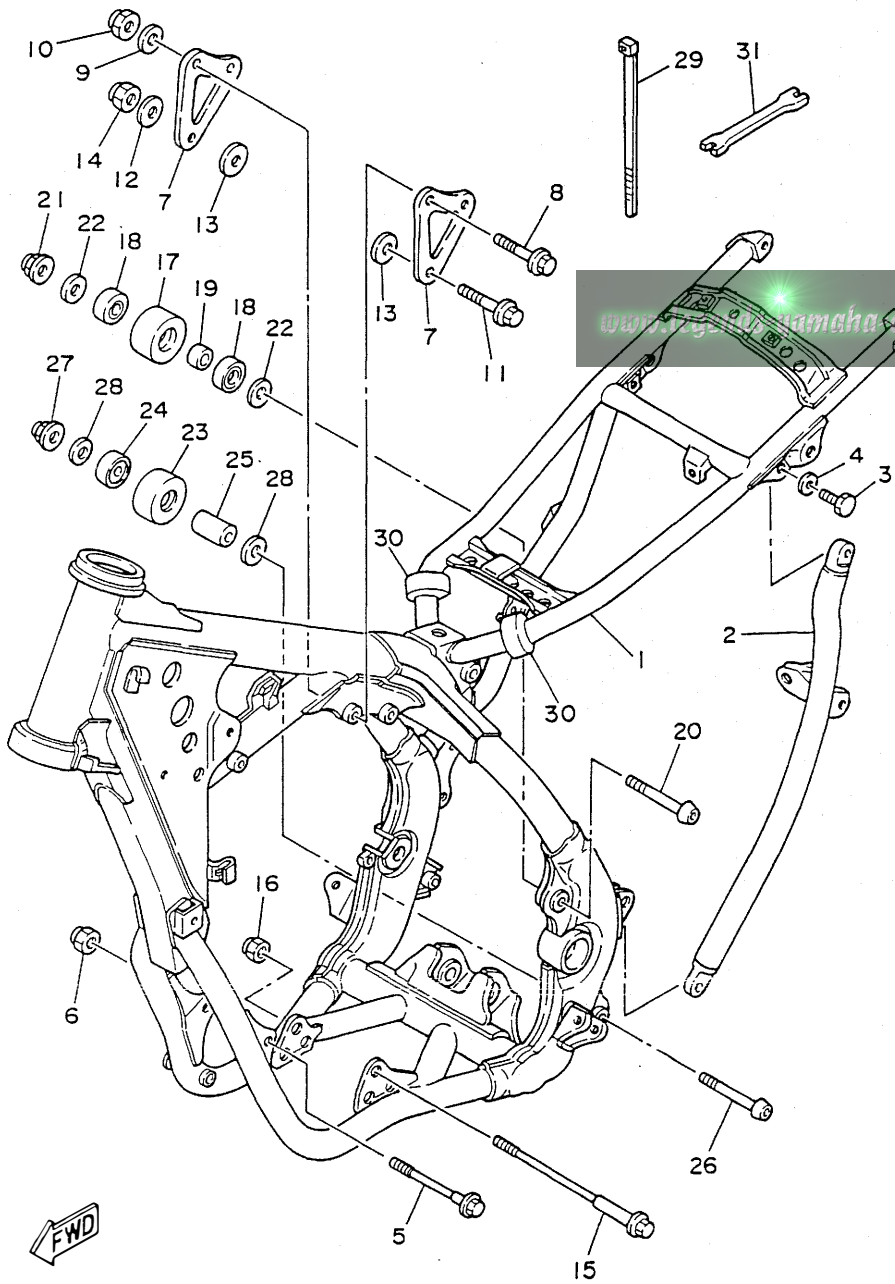

REF. NO.	PART NO.	DESCRIPTION	Q'TY	REMARKS
29	12R-82591-00	BAND	1	
30	3XJ-21717-00	DAMPER, side cover	2	
31	56A-28166-00	WRENCH, hexagon	1	



3XK1100-1160

FIG. 17 FENDER

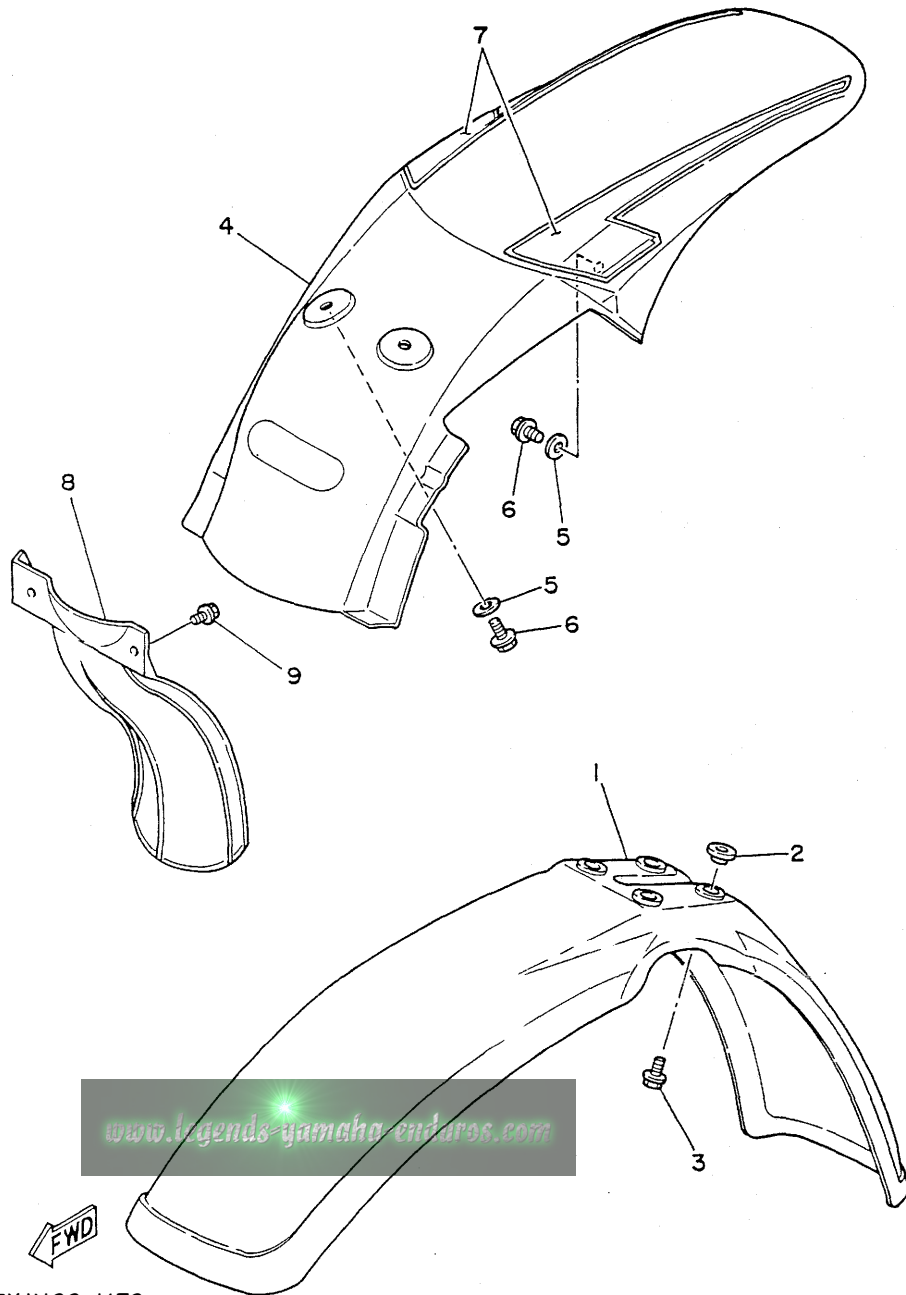

REF. NO.	PART NO.	DESCRIPTION	Q'TY	REMARKS
1	3XK-21511-00	FENDER, front	1	
2	3JD-21748-00	COLLAR	4	
3	90119-06063	BOLT, with washer	4	
4	3XJ-21611-00	FENDER, rear	1	
5	90201-06571	WASHER, plate	4	
6	90105-06553	BOLT, washer based	4	
7	3RB-2165A-01	GRAPHIC SET, rear fender	1	
8	39X-21642-00	GUARD, flap	1	
9	90119-06185	BOLT, with washer	2	

3XJ1100-1170

C8

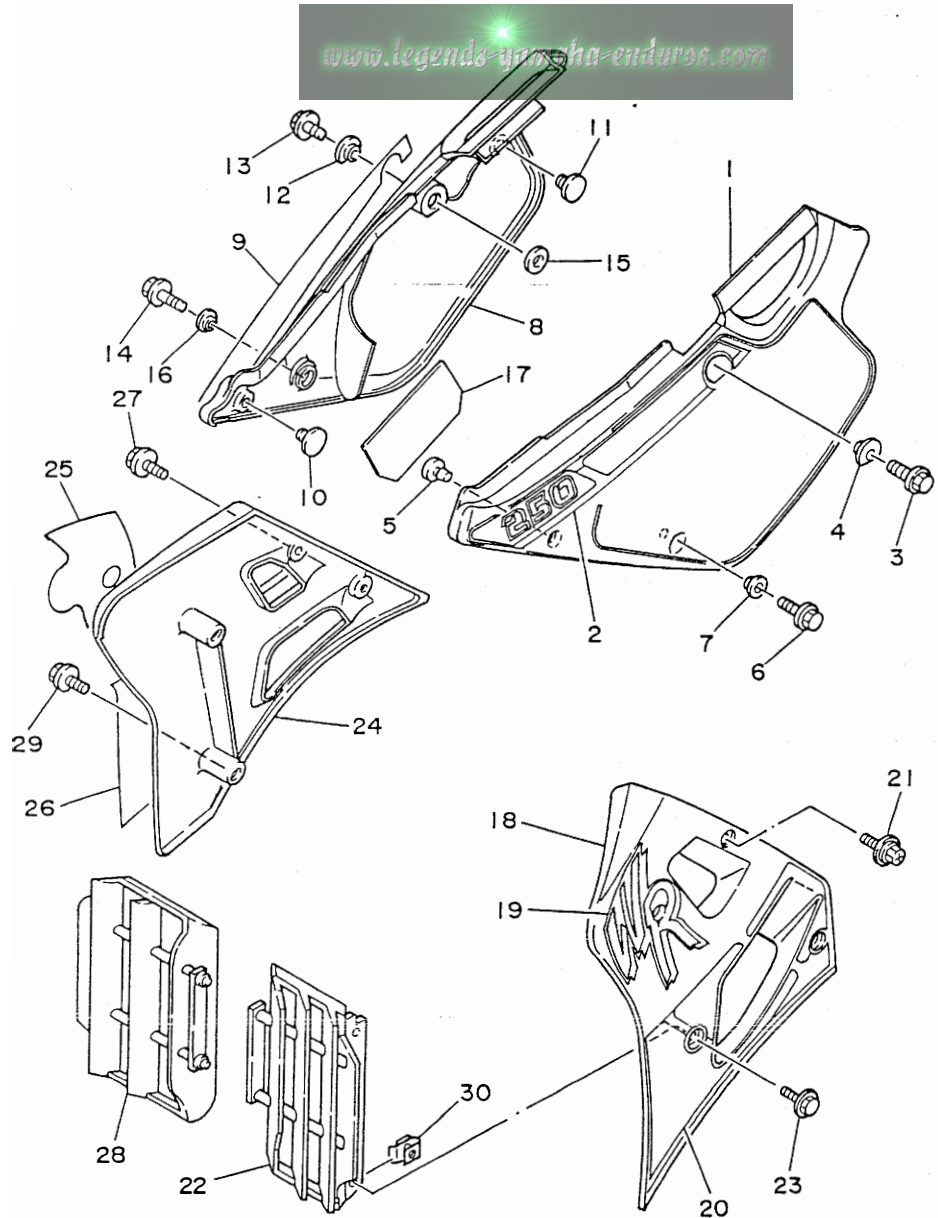

3RB3100-1180

FIG. 18 SIDE COVER

REF. NO.	PART NO.	DESCRIPTION	Q'TY	REMARKS
1	3XJ-21711-00	COVER, side 1	1	
2	3RB-2173L-20	GRAPHIC SET 1	1	
3	95023-08016	BOLT	1	
4	90387-084X5	COLLAR	1	
5	22W-24181-00	DAMPER, locating 1	1	
6	91021-06016	BOLT, flange	1	
7	90387-064X4	COLLAR	1	
8	3XJ-21721-00	COVER, side 2	1	
9	3RB-2174L-20	GRAPHIC SET 2	1	
10	22W-24181-00	DAMPER, locating 1	1	
11	3JD-24181-00	DAMPER, locating 1	1	
12	90387-084X5	COLLAR	1	
13	95023-08016	BOLT	1	
14	91021-06012	BOLT, flange	1	
15	92901-08200	WASHER, plain	1	
16	90387-064X4	COLLAR	1	
17	3XJ-2174A-00	INSULATOR, side cover	1	
18	3XK-21731-00	COVER, side 3	1	
19	3RB-24244-00	GRAPHIC, fuel tank 1	1	
20	3RB-24245-00	GRAPHIC, fuel tank 2	1	
21	90119-06192	BOLT, with washer	2	
22	3XJ-2172A-00	PANEL 1	1	
23	90119-05193	BOLT, with washer	2	
24	3XK-21741-00	COVER, side 4	1	
25	3RB-24248-00	GRAPHIC, fuel tank 5	1	
26	3RB-24250-00	GRAPHIC SET	1	
27	90119-06192	BOLT, with washer	2	
28	3XJ-2172A-00	PANEL 1	1	

FIG. 18 SIDE COVER

REF. NO.	PART NO.	DESCRIPTION	Q'TY	REMARKS
29	90119-05193	BOLT, with washer	2	
30	22W-21791-00	NUT	4	

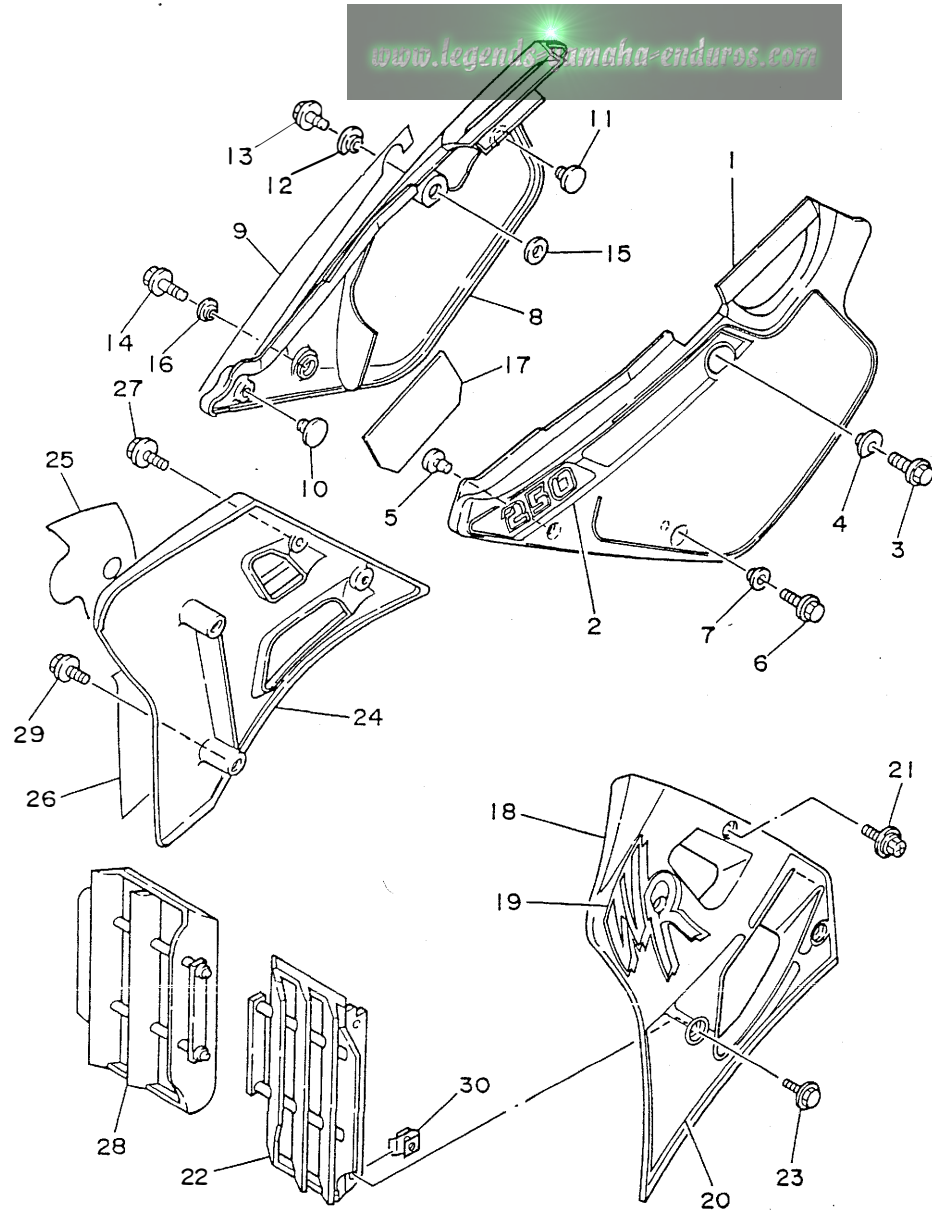

3RB3100-1180

C10

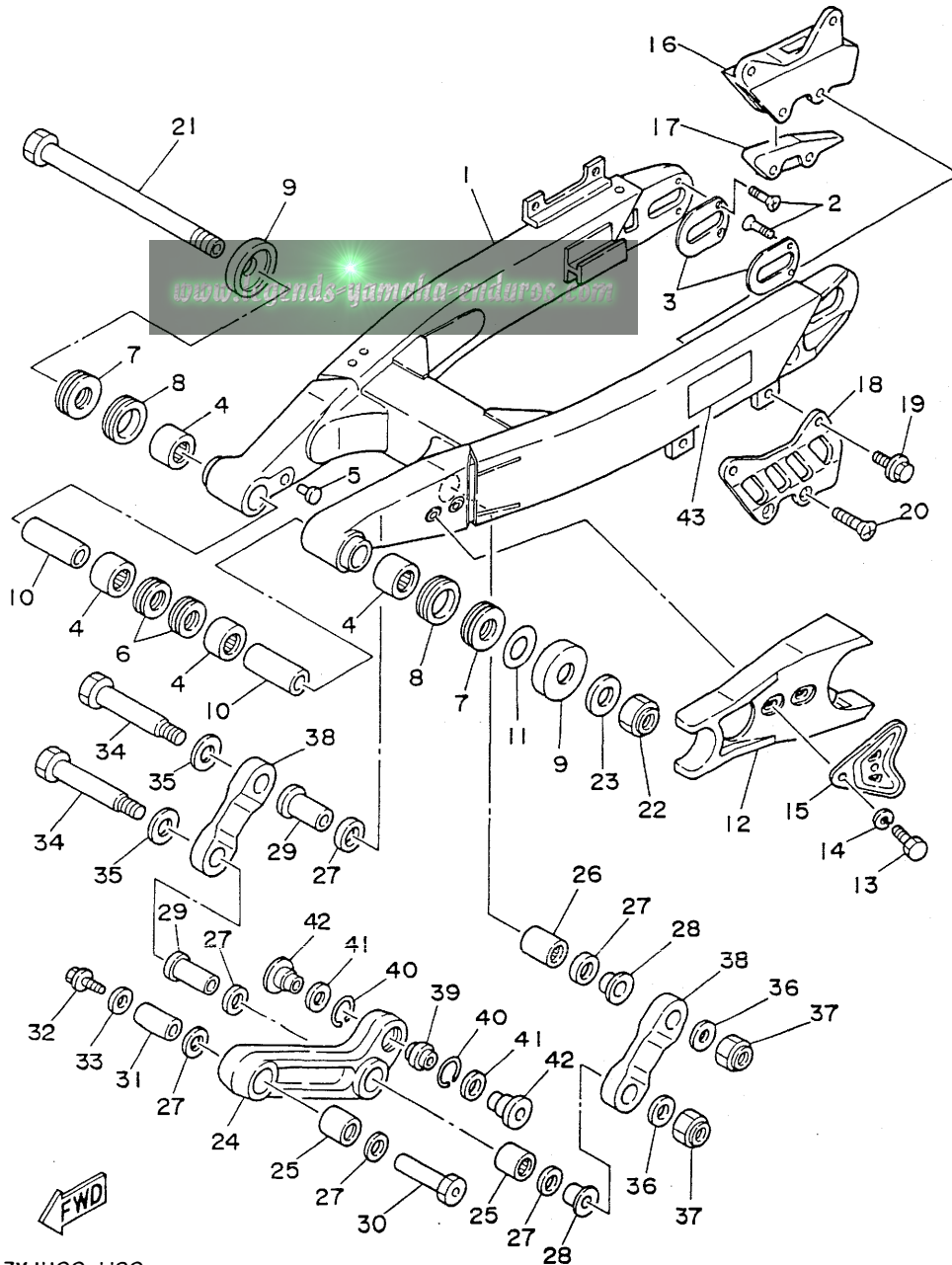

3XJ1100-1190

FIG. 19 REAR ARM

REF. NO.	PART NO.	DESCRIPTION	Q'TY	REMARKS
1	3XJ-22110-01	REAR ARM COMP.	1	
2	90151-04048	SCREW, countersunk	4	
3	3XJ-22355-00	PATCH A	2	
4	93317-22262	BEARING, cylindrical	4	UR
	93317-22263	BEARING, cylindrical	4	UR
5	90338-10150	PLUG	2	
6	93106-22019	OIL SEAL (DC 22-28-8)	2	
7	93342-22208	BEARING, thrust	2	
8	93108-35004	OIL SEAL (35-41-8)	2	
9	3R4-22129-00	COVER, thrust 2	2	
10	90380-16158	BUSH, solid	2	
11	156-22127-00	SHIM (0.3T)	1	UN
12	3JD-22151-00	SEAL, guard	1	
13	95023-06020	BOLT	2	
14	92990-06100	WASHER, spring	2	
15	3JD-22156-00	WASHER, plate	1	
16	3JD-22199-00	SUPPORT, chain	1	
17	3JD-22147-00	PROTECTOR, chain	1	
18	3JD-22128-00	COVER, thrust 1	1	
19	91001-06020	BOLT, flange	2	
20	98701-06035	SCREW, flat head	2	
21	1LX-22141-00	SHAFT, pivot	1	
22	90185-16127	NUT, self-locking	1	
23	90201-164H4	WASHER, plate	1	
24	3XJ-2217A-00	ARM, relay	1	
25	93315-22046	BEARING, cylindrical	2	
26	93315-22046	BEARING, cylindrical	1	
27	93109-20029	OIL SEAL	6	

C11

FIG. 19 REAR ARM

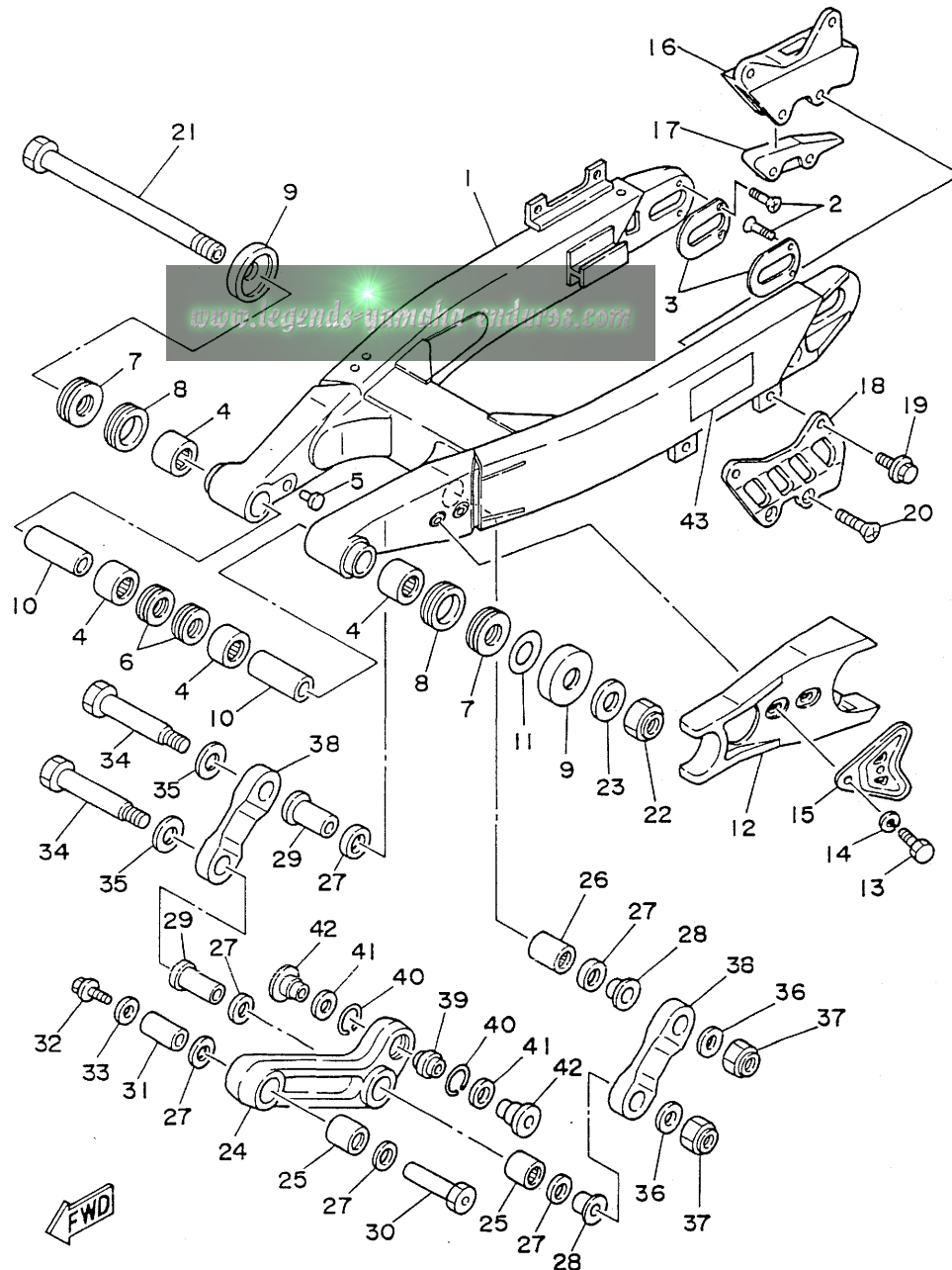

3XJ1100-1190

REF. NO.	PART NO.	DESCRIPTION	Q'TY	REMARKS
28	90387-164N2	COLLAR	2	
29	90387-164N3	COLLAR	2	
30	90179-10544	NUT	1	
31	90387-167R5	COLLAR	1	
32	91011-10016	BOLT, flange	1	
33	90201-106F2	WASHER, plate	1	
34	90109-142F4	BOLT	2	
35	90201-164H4	WASHER, plate	2	
36	90201-14740	WASHER, plate	2	
37	90185-14070	NUT, self-locking	2	
38	3XJ-2217F-00	ROD, connecting 1	2	
39	93399-99921	BEARING	1	
40	93440-30113	CIRCLIP	2	
41	3XJ-22475-00	SEAL, dust	2	
42	90387-103X9	COLLAR	2	
43	3XJ-2218A-00	EMBLEM, rear arm	2	

C12

FIG. 20 REAR SUSPENSION

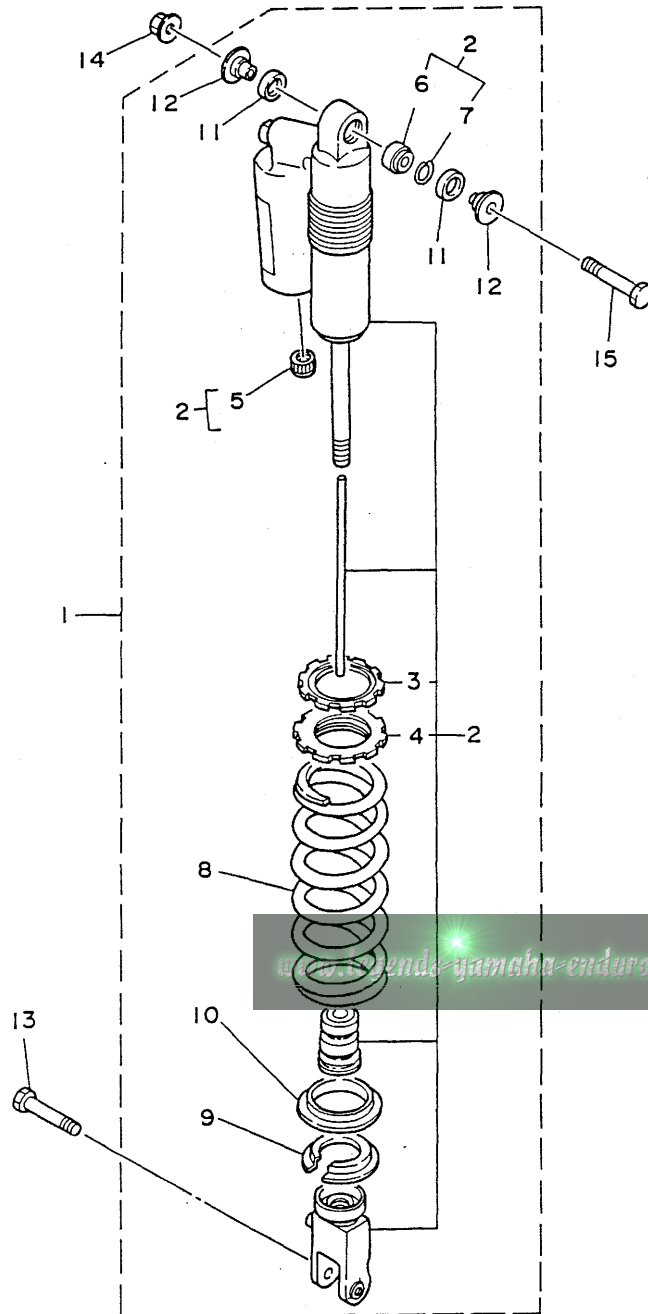

REF. NO.	PART NO.	DESCRIPTION	Q'TY	REMARKS
1	3RB-22210-00	SHOCK ABSORBER ASSY, rear	1	UR FOR U.S.A., OCEANIA
	3RB-22210-10	SHOCK ABSORBER ASSY, rear	1	UR FOR CANADA, EUROPE
2	3RB-22201-00	.DAMPER SUB ASSY	1	UR FOR U.S.A., OCEANIA
	3RB-22201-10	.DAMPER SUB ASSY	1	UR FOR CANADA, EUROPE
3	3SP-22234-00	..GUIDE, spring 3	1	
4	3SP-22213-00	..SEAT, spring upper	1	
5	24M-23184-00	..CAP, air valve	1	
6	3JD-22216-00	..BUSH, rear shock absorber	1	
7	43M-22274-00	..RING, stop	1	
8	3XK-22212-00	.SPRING (K=5.0)	1	
9	3JD-22214-00	.GUIDE, spring 1	1	
10	3JD-22224-00	.GUIDE, spring 2	1	
11	3JD-22475-00	.SEAL, dust	2	
12	3XJ-22253-00	.COLLAR, distance	2	
13	90105-10614	BOLT, washer based	1	
14	95611-10200	NUT, self-locking	1	
15	3SP-22241-00	BOLT 1	1	



3XJ1100-1200

C13

FIG. 21 STEERING

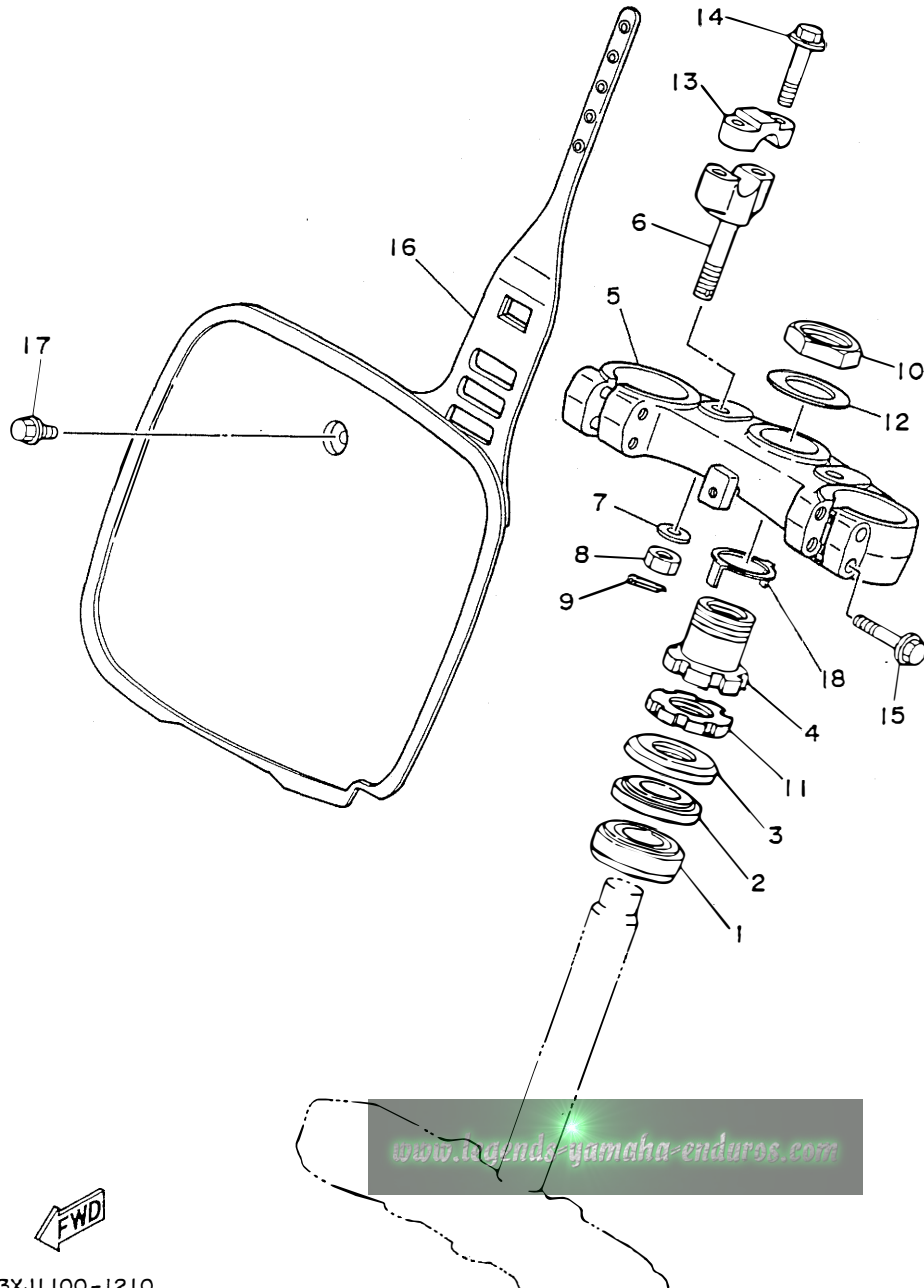

REF. NO.	PART NO.	DESCRIPTION	Q'TY	REMARKS
1	93332-00067	BEARING	1	
2	93332-00068	BEARING	1	
3	2HG-23416-00	COVER, ball race 2	1	
4	90179-28603	NUT	1	
5	3XJ-23435-00	CROWN, handle	1	
6	3SP-23442-00	HOLDER, handle lower	2	
7	92990-12200	WASHER, plain	2	
8	95611-12100	NUT, u	2	
9	91401-25020	PIN, cotter	2	
10	90170-36394	NUT	1	
11	90179-28602	NUT	1	
12	90201-365M5	WASHER, plate	1	
13	3SP-23441-00	HOLDER, handle upper	2	
14	95023-08035	BOLT	4	
15	95023-08050	BOLT	4	
16	3XJ-23485-01	PLATE, number	1	
17	90119-06185	BOLT, with washer	1	
18	3SP-23418-00	WASHER, special	1	

www.agenda-yamaha-enduros.com



3XJ1100-1210

C14

FIG. 22 FRONT FORK

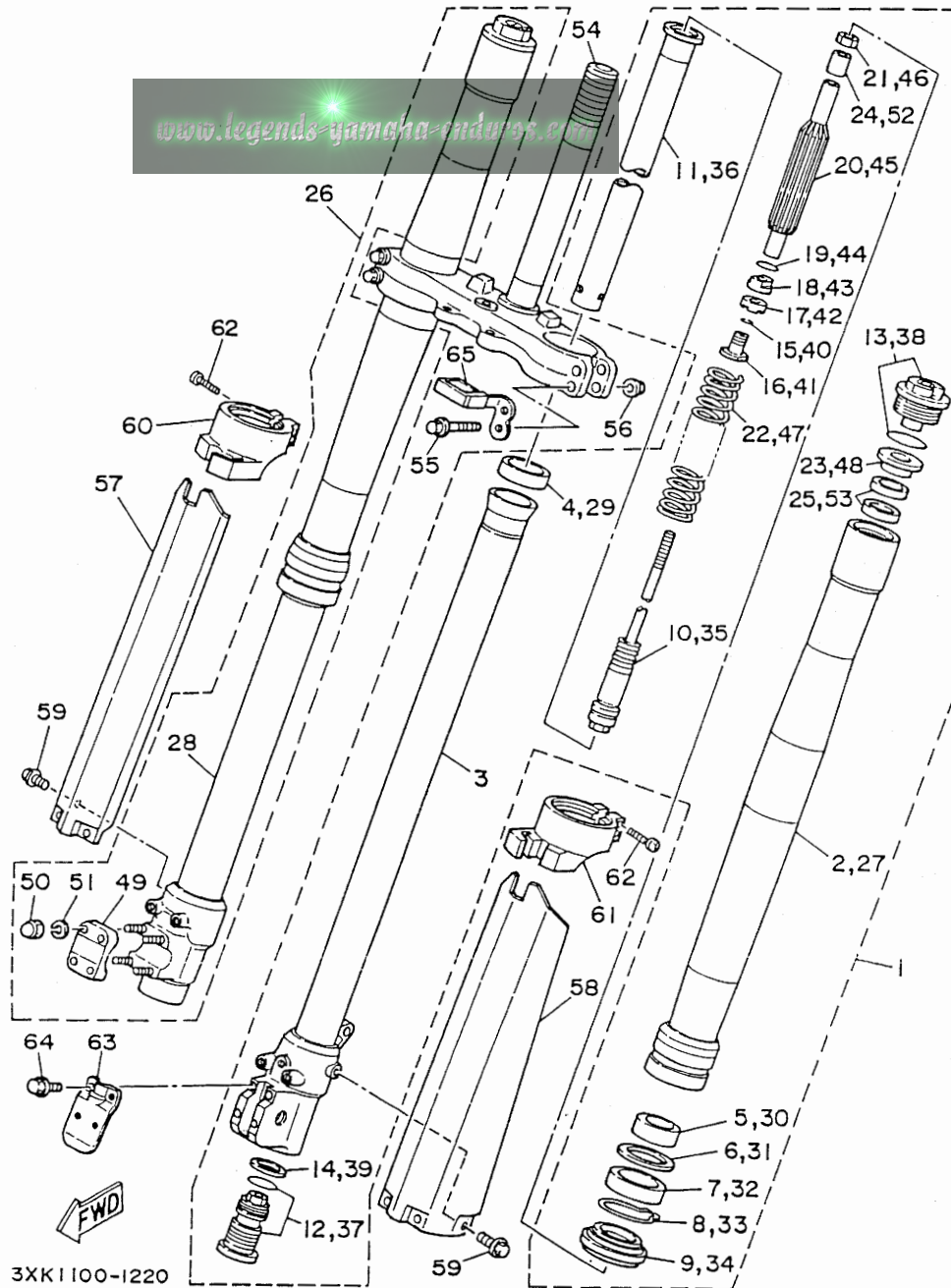

REF. NO.	PART NO.	DESCRIPTION	Q'TY	REMARKS
1	3RB-23102-10	FRONT FORK ASSY (L.H)	1	
2	3XJ-23136-L0	.TUBE, outer 2	1	
3	3XJ-23120-L0	.INNER TUBE COMP.2	1	
4	3XJ-23171-L0	.PISTON, front fork	1	
5	3XJ-23125-L0	.METAL, slide 1	1	
6	4V4-23146-L0	.WASHER, oil seal	1	
7	3XJ-23145-L0	.OIL SEAL	1	
8	4V4-23153-L0	.RING, snap	1	
9	3XJ-23144-L0	.SEAL, dust	1	
10	3XJ-2314A-M0	.PISTON ROD ASSY	1	
11	3XJ-23170-L0	.CYLINDER COMP., front fork	1	
12	3XJ-2316A-L0	.VALVE COMP.	1	
13	3XJ-23111-L0	.BOLT, cap	1	
14	2HH-23158-L0	.GASKET	1	
15	3XJ-23153-L0	.RING, snap	2	
16	3XJ-23113-L0	.COLLAR	1	
17	3XJ-23166-L0	.SPACER, oil lock	1	
18	3XJ-23778-L0	.NUT	1	
19	36Y-23147-10	.O-RING	1	
20	3XJ-23142-L0	.SEAT, spring upper	1	
21	3XJ-23357-L0	.NUT	1	
22	3XK-23141-L0	.SPRING, front fork (K=0.390)	1	
23	3XJ-23143-L0	.SEAT, spring lower	1	
24	3XJ-23363-L0	.COLLAR 1	1	
25	3XJ-23364-L0	.COLLAR 2	2	
26	3RB-23103-10	FRONT FORK ASSY (R.H)	1	
27	3XJ-23136-L0	.TUBE, outer 2	1	
28	3XJ-23110-L0	.INNER TUBE COMP.1	1	

FIG. 22 FRONT FORK

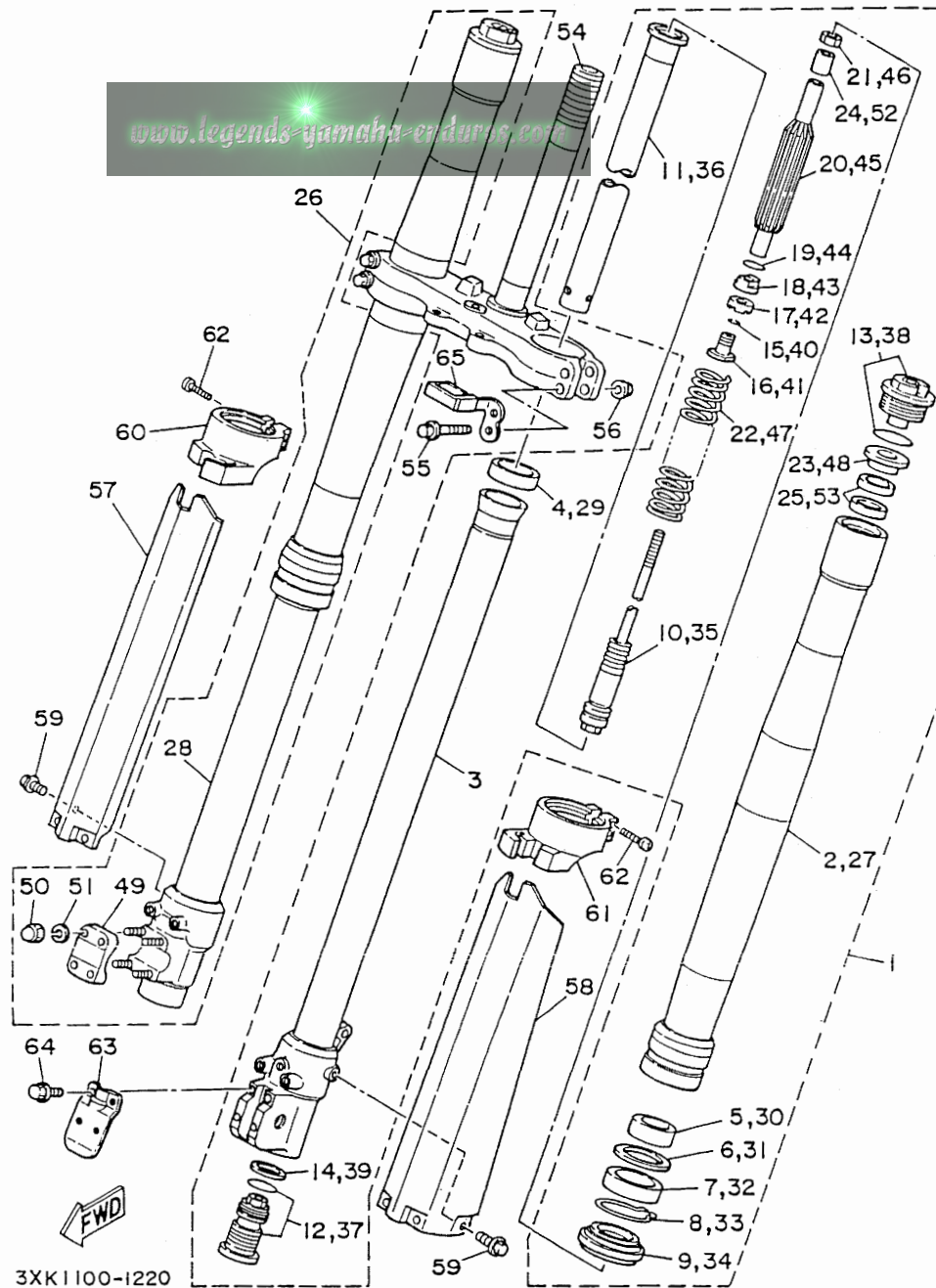

3XK1100-1220

REF. NO.	PART NO.	DESCRIPTION	Q'TY	REMARKS
29	3XJ-23171-LO	.PISTON, front fork	1	
30	3XJ-23125-LO	.METAL, slide 1	1	
31	4V4-23146-LO	.WASHER, oil seal	1	
32	3XJ-23145-LO	.OIL SEAL	1	
33	4V4-23153-LO	.RING, snap	1	
34	3XJ-23144-LO	.SEAL, dust	1	
35	3XJ-2314A-MO	.PISTON ROD ASSY	1	
36	3XJ-23170-LO	.CYLINDER COMP., front fork	1	
37	3XJ-2316A-LO	.VALVE COMP.	1	
38	3XJ-23111-LO	.BOLT, cap	1	
39	2HH-23158-LO	.GASKET	1	
40	3XJ-23153-LO	.RING, snap	2	
41	3XJ-23113-LO	.COLLAR	1	
42	3XJ-23166-LO	.SPACER, oil lock	1	
43	3XJ-23778-LO	.NUT	1	
44	36Y-23147-10	.O-RING	1	
45	3XJ-23142-LO	.SEAT, spring upper	1	
46	3XJ-23357-LO	.NUT	1	
47	3XK-23141-LO	.SPRING, front fork (K=0.390)	1	
48	3XJ-23143-LO	.SEAT, spring lower	1	
49	3XJ-23167-LO	.HOLDER, axle	1	
50	5Y3-23393-00	.NUT, special	4	
51	92990-06100	.WASHER, spring	4	
52	3XJ-23363-LO	.COLLAR 1	1	
53	3XJ-23364-LO	.COLLAR 2	2	
54	3XJ-23340-LO	UNDER BRACKET COMP.	1	
55	95021-08060	BOLT, flange	4	
56	95701-08500	NUT, flange	4	

D2

FIG. 22 FRONT FORK

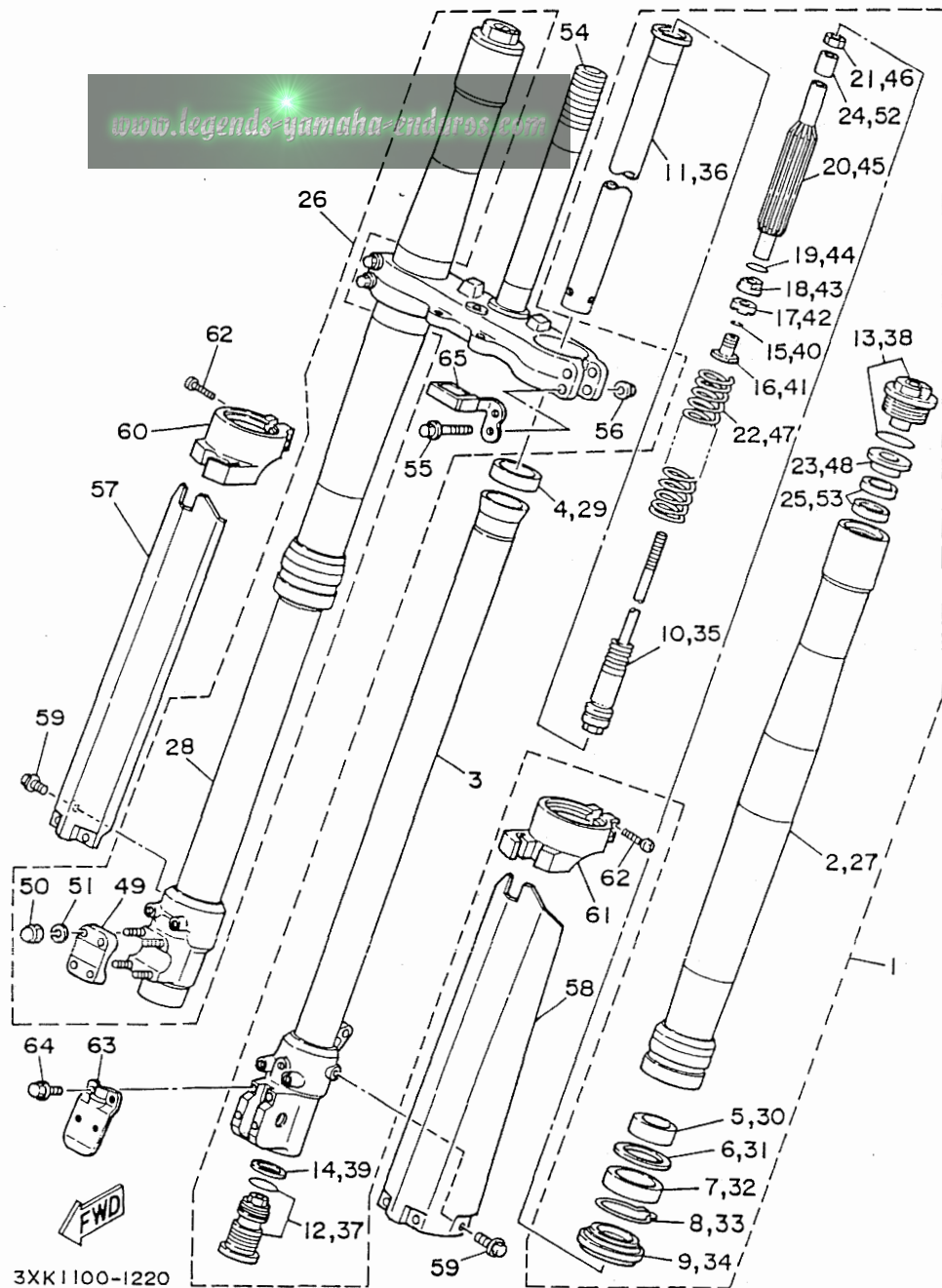

REF. NO.	PART NO.	DESCRIPTION	Q'TY	REMARKS
57	3XJ-2314J-LO	PROTECTOR COMP., 2	1	
58	3XJ-2314H-LO	PROTECTOR COMP., 1	1	
59	3SP-23356-LO	BOLT 2	6	
60	3SP-2314G-LO	PROTECTOR GUIDE COMP., 2	1	
61	3SP-2314F-LO	PROTECTOR GUIDE COMP., 1	1	
62	98501-04030	SCREW, pan head	4	
63	3SP-2314E-LO	COVER, hose	1	
64	3SP-23346-LO	BOLT 1	4	
65	3JD-23389-01	GUIDE, cable	1	

3XK1100-1220



D3

FIG. 23 FUEL TANK

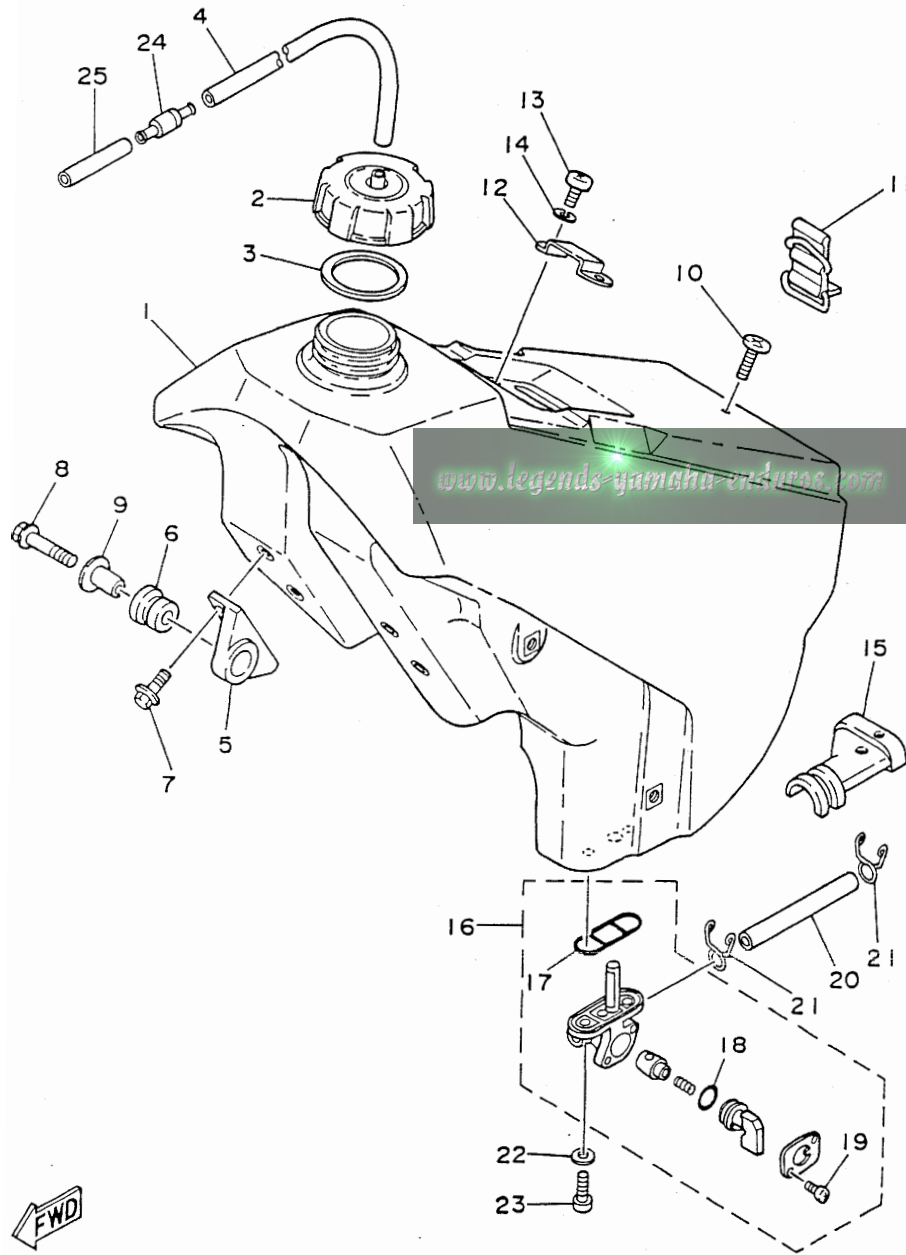

REF. NO.	PART NO.	DESCRIPTION	Q'TY	REMARKS
1	3XK-24110-00	FUEL TANK COMP.	1	
2	5X7-24611-01	BODY, cap	1	
3	5X7-24612-00	GASKET, cap	1	
4	90445-09100	HOSE	1	
5	24X-24144-00	HOLDER, damper	2	
6	90480-18354	GROMMET	2	
7	95023-06016	BOLT	4	
8	95023-06035	BOLT	2	
9	3JD-24186-00	WASHER, special	2	
10	98980-06020	SCREW, bind	1	
11	3SP-24173-00	BAND, tank fitting 1	1	
12	5X6-2412F-00	BRACKET, seat	1	
13	97003-06012	BOLT	2	
14	92990-06100	WASHER, spring	2	
15	1LX-24181-00	DAMPER, locating 1	1	
16	2VN-24500-00	FUEL COCK ASSY 1	1	
17	4X8-24512-00	.O-RING	1	
18	4X8-24534-00	.SEAL, cock	1	
19	98503-03008	.SCREW, pan head	2	
20	1RK-24311-00	PIPE, fuel 1	1	
21	90467-10008	CLIP	2	
22	90202-05193	WASHER, plate	2	
23	90149-06011	SCREW	2	
24	3XJ-24380-00	PIPE JOINT ASSY	1	
25	90445-09058	HOSE	1	



3SP1100-0230

D4

FIG. 24 SEAT

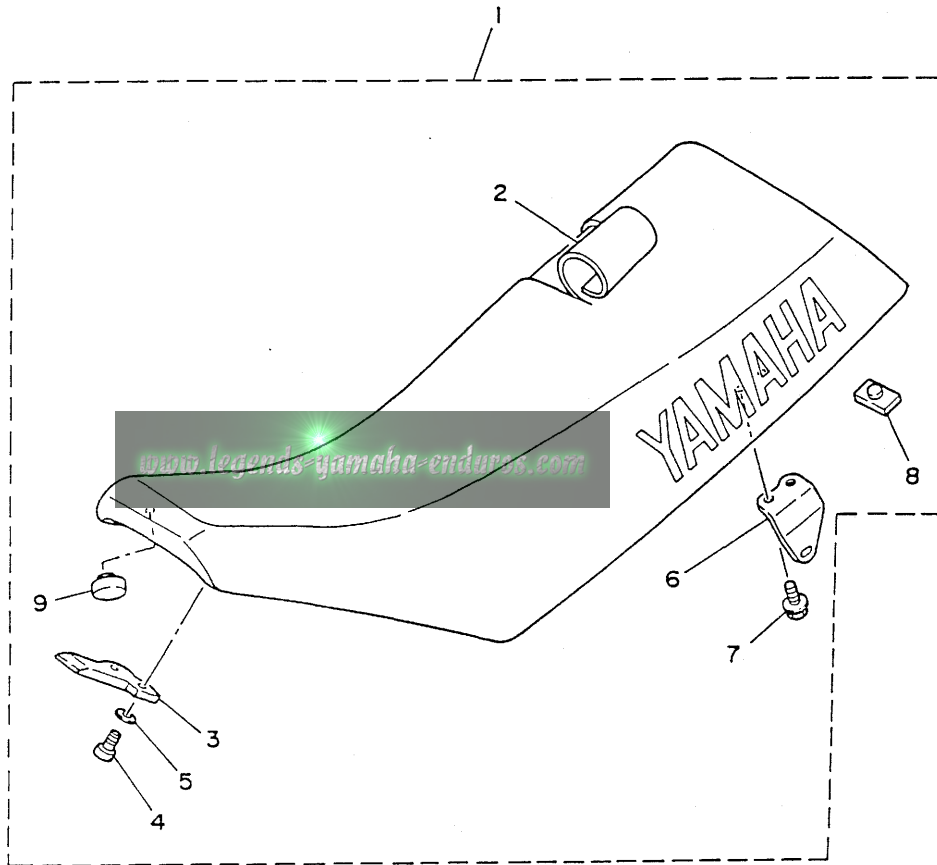

REF. NO.	PART NO.	DESCRIPTION	Q'TY	REMARKS
1	3RB-24770-20	SEMI-DOUBLE SEAT ASSY	1	
2	3RB-24731-20	.COVER, seat	1	
3	5X6-24748-10	.BRACKET, seat	1	
4	98501-06012	.SCREW, pan head	2	
5	92901-06600	.WASHER, plate	2	
6	1LX-24738-01	.BRACKET, seat	2	
7	95023-06012	.BOLT	4	
8	509-24724-00	.DAMPER, seat	1	
9	3L7-24724-00	.DAMPER, seat	2	



3XJ1100-1240

D5

FIG. 25 FRONT WHEEL

REF. NO.	PART NO.	DESCRIPTION	Q'TY	REMARKS
1	3SP-25111-00	HUB, front	1	
2	93306-20209	BEARING (B6202)	2	
3	90560-15352	SPACER	1	
4	93102-20281	OIL SEAL (SD 20-35-5)	2	
5	94416-21455	RIM (1.60-21)	1	
6	1LX-25104-00	SPOKE SET, front	1	
7	94108-217X8	TIRE (80/100-21-ED11)	1	BRIDGESTONE
8	94209-21277	TUBE (MCS 90/90-21 TR-4)	1	BRIDGESTONE
9	94330-21084	BAND, rim (3.00-21)	1	BRIDGESTONE
10	5X2-25394-00	SPACER, bead	1	
11	55U-25181-01	AXLE, wheel	1	
12	90387-152V1	COLLAR	1	
13	322-25118-00	COVER, hub dust	2	
14	90387-151V9	COLLAR	1	

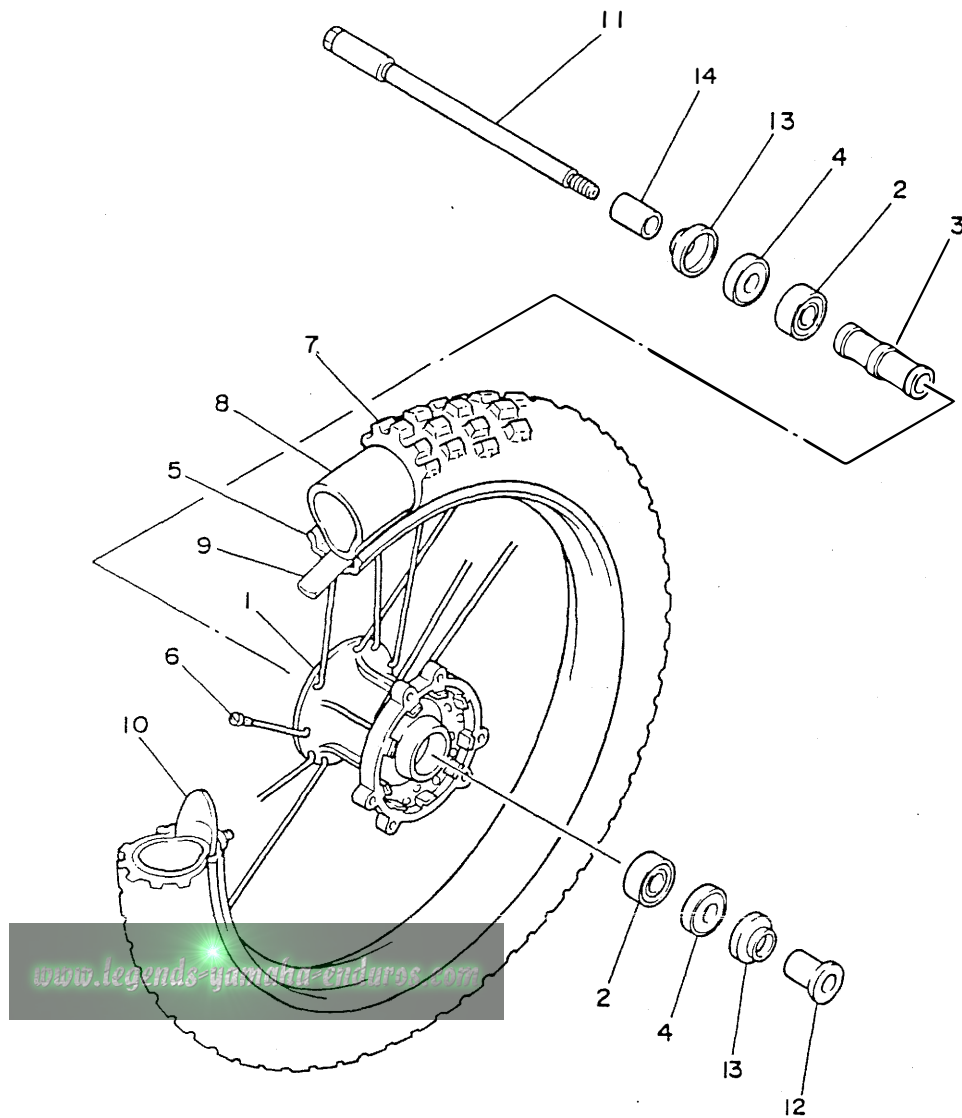

2HH100-7250

D6

FIG. 26 FRONT BRAKE CALIPER

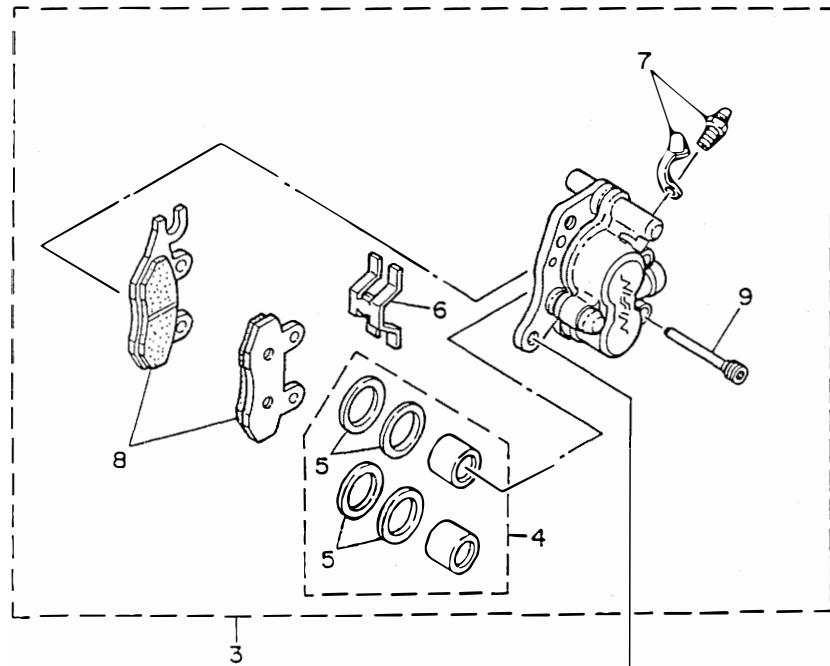

REF. NO.	PART NO.	DESCRIPTION	Q'TY	REMARKS
1	3SP-2582T-00	DISC, brake	1	
2	90149-06272	SCREW	6	
3	3SP-2580T-00	CALIPER ASSY (LEFT)	1	
4	3JD-W0057-00	.PISTON ASSY, caliper	1	
5	3JD-W0047-00	..CALIPER SEAL KIT	1	
6	3JD-25919-00	.SUPPORT, pad	1	
7	1UY-W0048-50	.BREED SCREW KIT	1	
8	3SP-W0045-00	.BRAKE PAD KIT	1	
9	3GD-25933-00	.PIN, pad	2	
10	97301-08040	BOLT	2	
11	92990-08100	WASHER, spring	2	
12	92901-08600	WASHER, plate	2	

www.legends4wheels.com



3SP1100-0260

D7

FIG. 27 REAR WHEEL

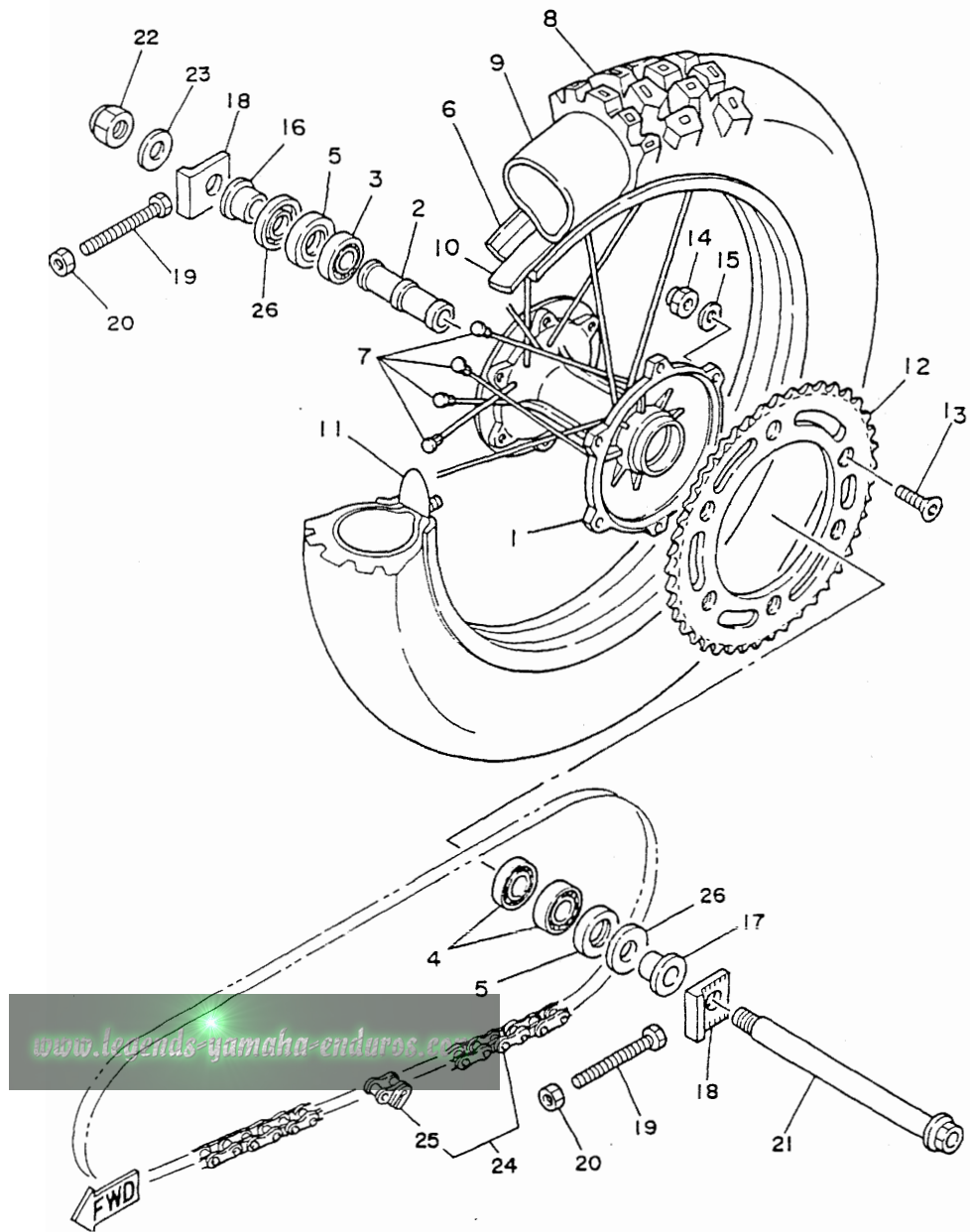

3XJ1100-1270

REF. NO.	PART NO.	DESCRIPTION	Q'TY	REMARKS
1	3SP-25311-00	HUB, rear	1	
2	3JD-25317-01	SPACER, bearing	1	
3	93306-00418	BEARING	1	
4	93306-00438	BEARING	2	
5	93106-28023	OIL SEAL	2	
6	94421-18456	RIM (2.15-18)	1	
7	2VN-25304-00	SPOKE SET, rear	1	
8	94111-187X9	TIRE (110/100-18-ED12)	1	BRIDGESTONE
9	94213-18232	TUBE (MC130/80-18)	1	BRIDGESTONE
10	94340-18086	BAND, rim (4.00-18)	1	BRIDGESTONE
11	39X-25394-00	SPACER, bead	2	
12	26A-25452-50	SPROCKET, driven (52T)	1	STD
	39W-25444-01	SPROCKET, driven (44T)	1	AP
	39W-25445-01	SPROCKET, driven (45T)	1	AP
	39W-25446-01	SPROCKET, driven (46T)	1	AP
	39W-25448-00	SPROCKET, driven (48T)	1	AP
	39W-25450-00	SPROCKET, driven (50T)	1	AP
	3JD-25451-01	SPROCKET, driven (51T)	1	AP
13	90109-08792	BOLT	6	
14	95611-08100	NUT, u	6	
15	90201-081A6	WASHER, plate	6	
16	90387-203V0	COLLAR	1	
17	90387-200Y5	COLLAR	1	
18	3SP-25388-00	PULLER, chain 1	2	
19	90101-08699	BOLT	2	
20	95701-08500	NUT, flange	2	
21	3JD-25381-01	AXLE, wheel	1	
22	90185-18104	NUT, self-locking	1	

FIG. 27 REAR WHEEL

REF. NO.	PART NO.	DESCRIPTION	Q'TY	REMARKS
23	92990-18600	WASHER	1	
24	94581-44116	CHAIN	1	
25	94681-44001	.JOINT, chain	1	
26	4V4-25367-00	COVER, hub dust	2	

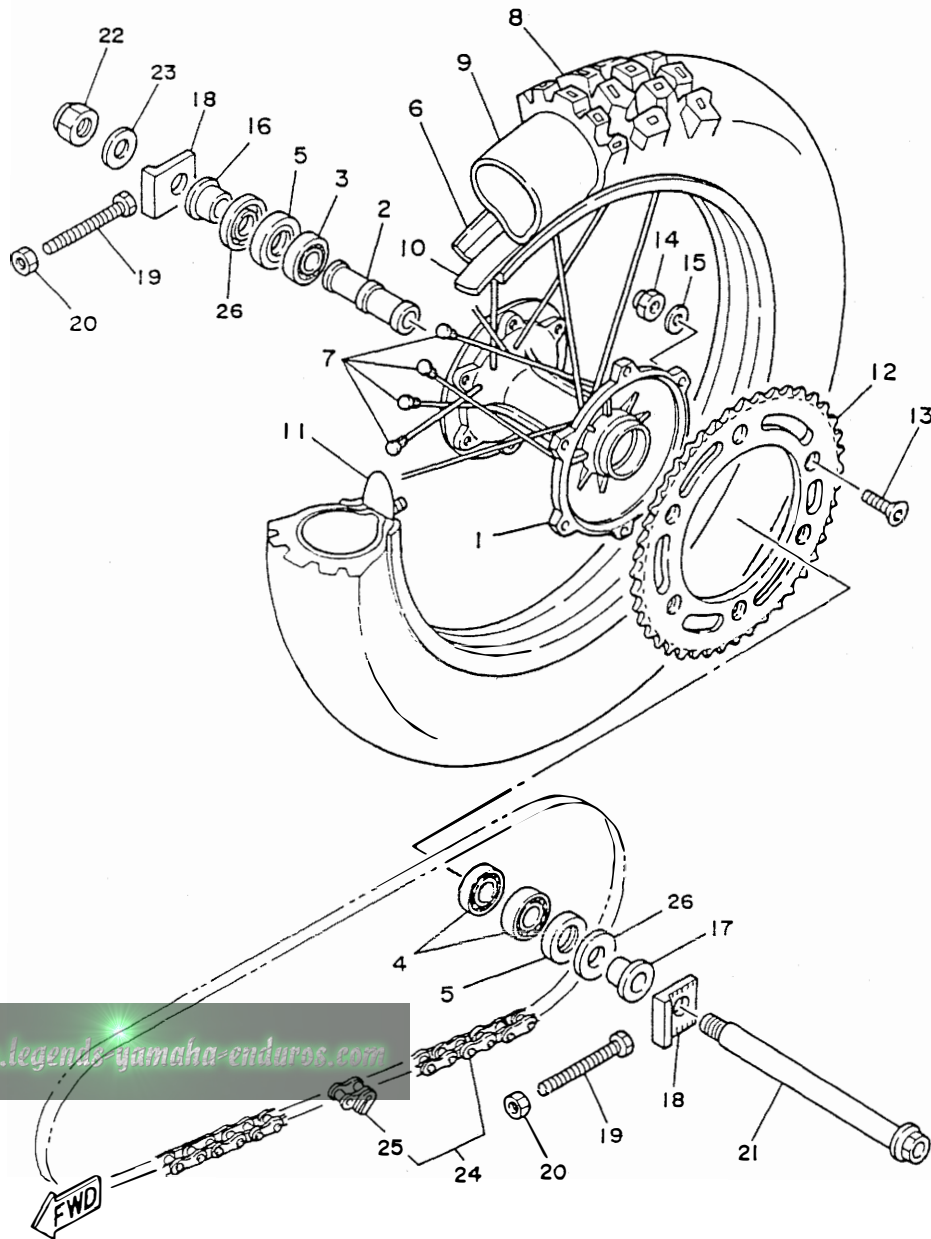

3XJ1100-1270

D9

FIG. 28 REAR BRAKE CALIPER

REF. NO.	PART NO.	DESCRIPTION	Q'TY	REMARKS
1	3XJ-2582W-00	DISC, rear brake 2	1	
2	90149-06272	SCREW	6	
3	3SP-2580W-00	CALIPER ASSY, rear 2	1	
4	3SP-W0057-50	.PISTON ASSY, caliper	1	
5	3JD-W0047-50	..CALIPER SEAL KIT	1	
6	3SP-25919-51	.SUPPORT, pad	1	
7	1UY-W0048-50	.BREED SCREW KIT	1	
8	3SP-W0046-00	.BRAKE PAD KIT, 2	1	
9	3GD-25827-00	..SHIM, caliper	1	
10	3SP-25924-51	.PIN, pad	2	
11	3XJ-25920-00	SUPT. BRKT. ASSY.	1	
12	91311-08025	BOLT	2	
13	3JD-27491-00	PROTECTOR	1	
14	92011-06012	SCREW	2	

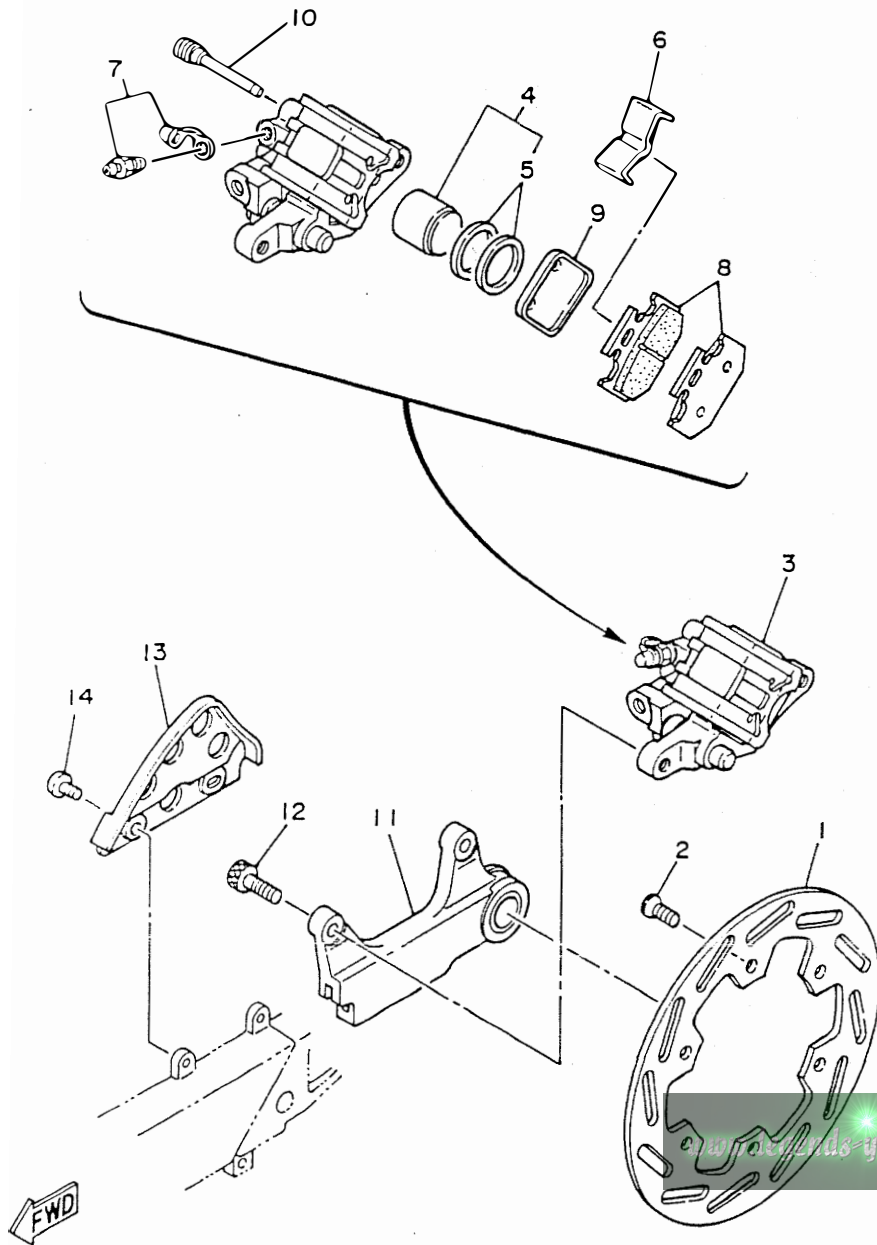

3SP1100-0280

FIG. 29 STEERING HANDLE. CABLE

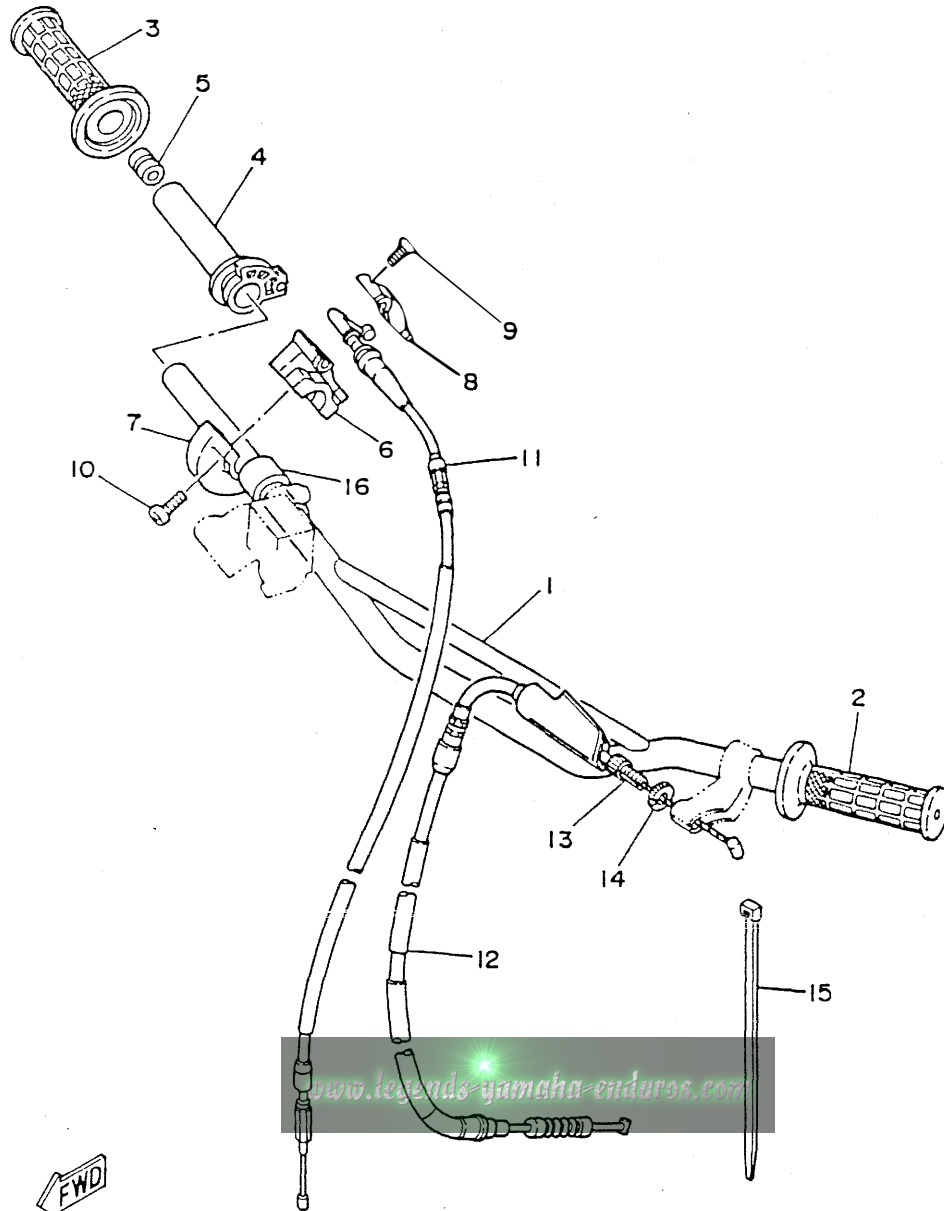

REF. NO.	PART NO.	DESCRIPTION	Q'TY	REMARKS
1	3XJ-26111-00	HANDLEBAR	1	
2	1LX-26241-01	GRIP (LEFT)	1	
3	1LX-26242-01	GRIP (RIGHT)	1	
4	23X-26243-00	TUBE, throttle guide	1	
5	688-82535-00	GROMMET	1	
6	23X-26281-00	CAP, grip upper	1	
7	431-26282-01-98	CAP, grip lower	1	LOW GLOSS BLACK
8	5X2-2628H-01	CAP, wire	1	
9	98706-04012	SCREW, flat head	2	
10	98506-05016	SCREW, pan head	2	
11	3JD-26311-00	CABLE, throttle 1	1	
12	3XK-26335-00	CABLE, clutch	1	
13	90123-08090	BOLT	1	
14	90179-08401	NUT	1	
15	90464-14117	CLAMP	1	
16	90560-22281	SPACER	1	



3JE1010-9290

D11

FIG. 30 FRONT MASTER CYLINDER

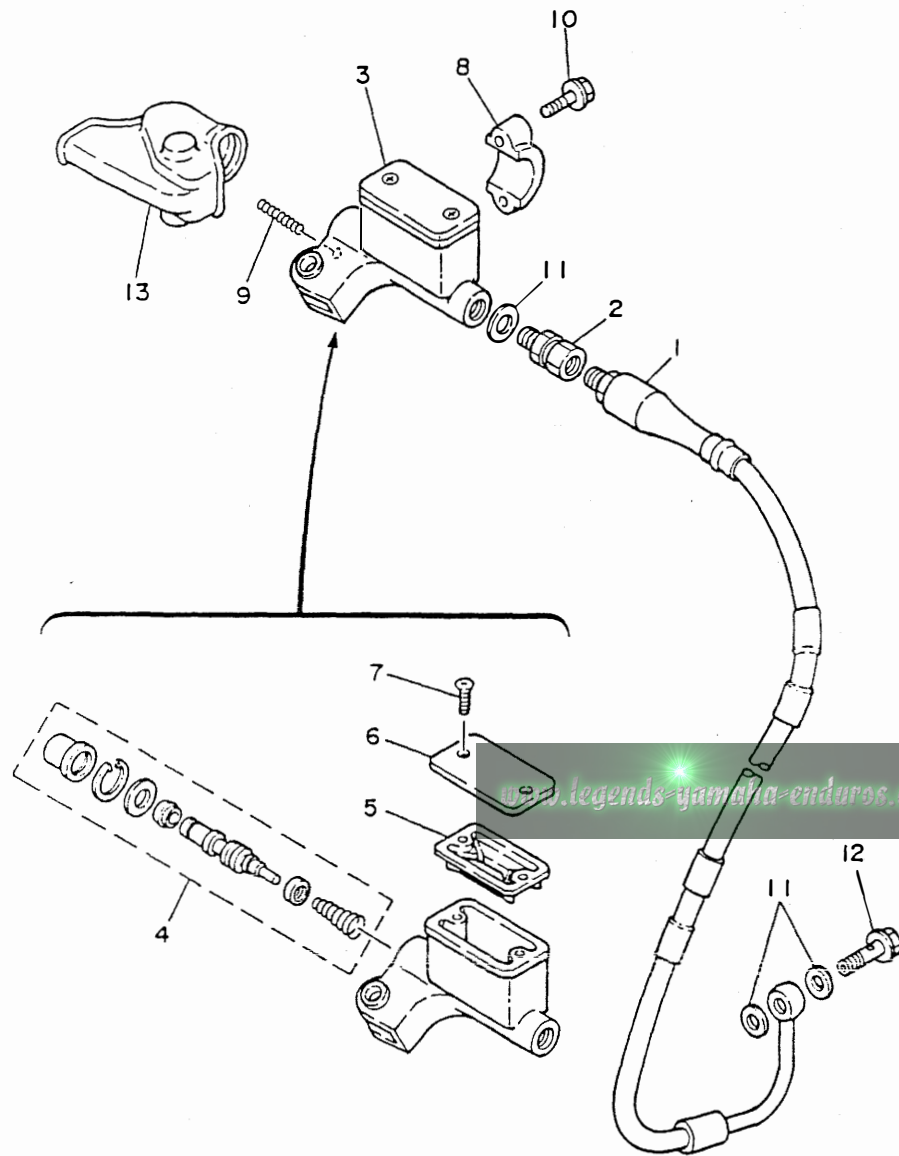

REF. NO.	PART NO.	DESCRIPTION	Q'TY	REMARKS
1	3SP-25872-00	HOSE, brake 1	1	
2	3LC-25885-00	JOINT	1	
3	3SP-25870-00	MASTER CYLINDER SUB ASSY	1	
4	3SP-W0041-00	.CYLINDER KIT, master	1	
5	56A-25854-00	.DIAPHRAGM, reservoir	1	
6	2VN-25852-00	.CAP, reservoir	1	
7	98706-04012	.SCREW, flat head	2	
8	56A-25867-00	BRACKET, master cylinder	1	
9	90501-061G2	SPRING, compression	1	
10	95026-06025	BOLT, flange	2	
11	90201-10118	WASHER, plate	3	
12	90401-10034	BOLT, union	1	
13	56A-26372-01	COVER, handle lever 1	1	



3SP1100-0300

D12

FIG. 31 STAND, FOOTREST

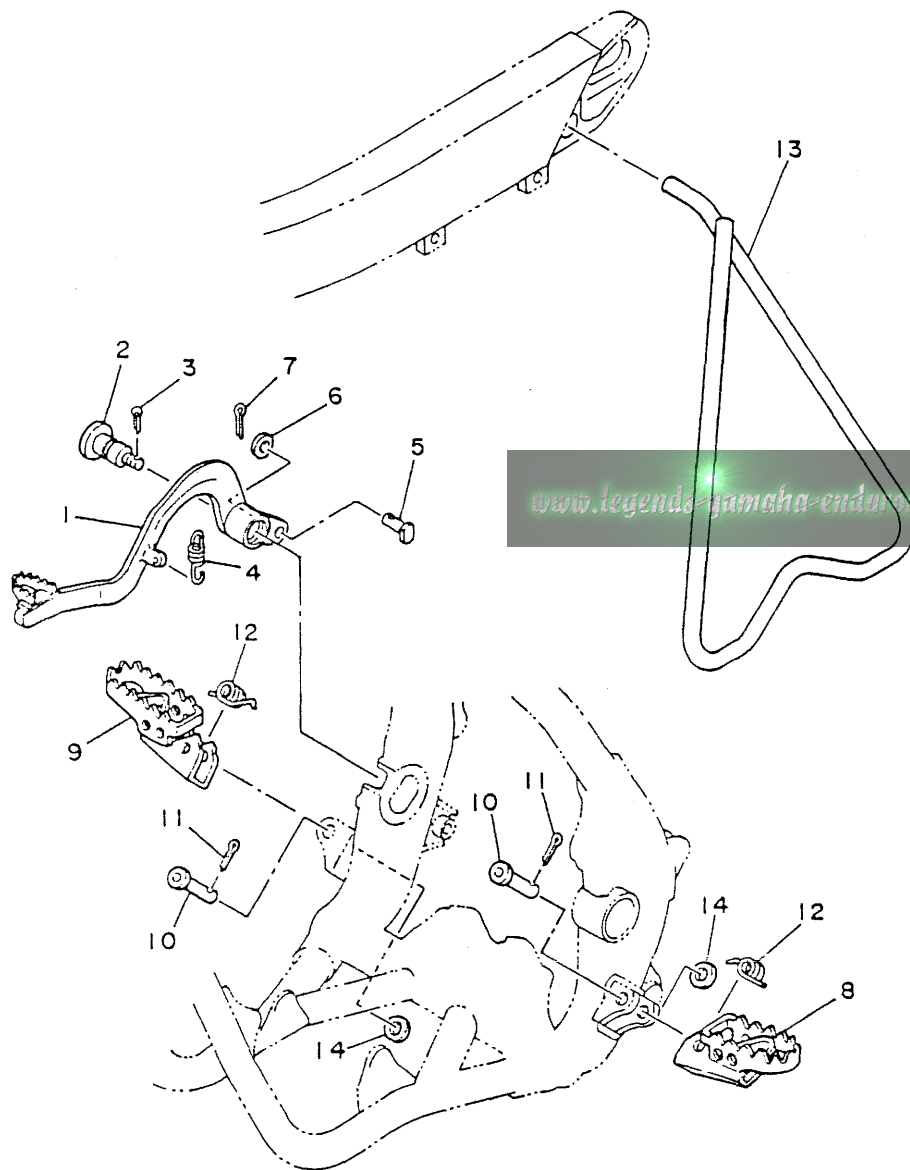

REF. NO.	PART NO.	DESCRIPTION	Q'TY	REMARKS
1	3SP-27200-00	PEDAL, brake	1	
2	3XJ-27217-00	BOLT	1	
3	91401-20015	PIN, cotter	1	
4	90506-14410	SPRING, tension	1	
5	90240-08120	PIN, clevis	1	
6	92901-08600	WASHER, plate	1	
7	91401-25020	PIN, cotter	1	
8	3SP-27411-00	FOOTREST 1	1	
9	3SP-27421-00	FOOTREST 2	1	
10	90240-10117	PIN, clevis	2	
11	91401-25020	PIN, cotter	2	
12	90508-28777	SPRING, torsion	2	
13	3SP-27311-00	STAND, side	1	
14	90201-10119	WASHER, plate	2	



3XK1100-1310

D13

FIG. 32 REAR MASTER CYLINDER

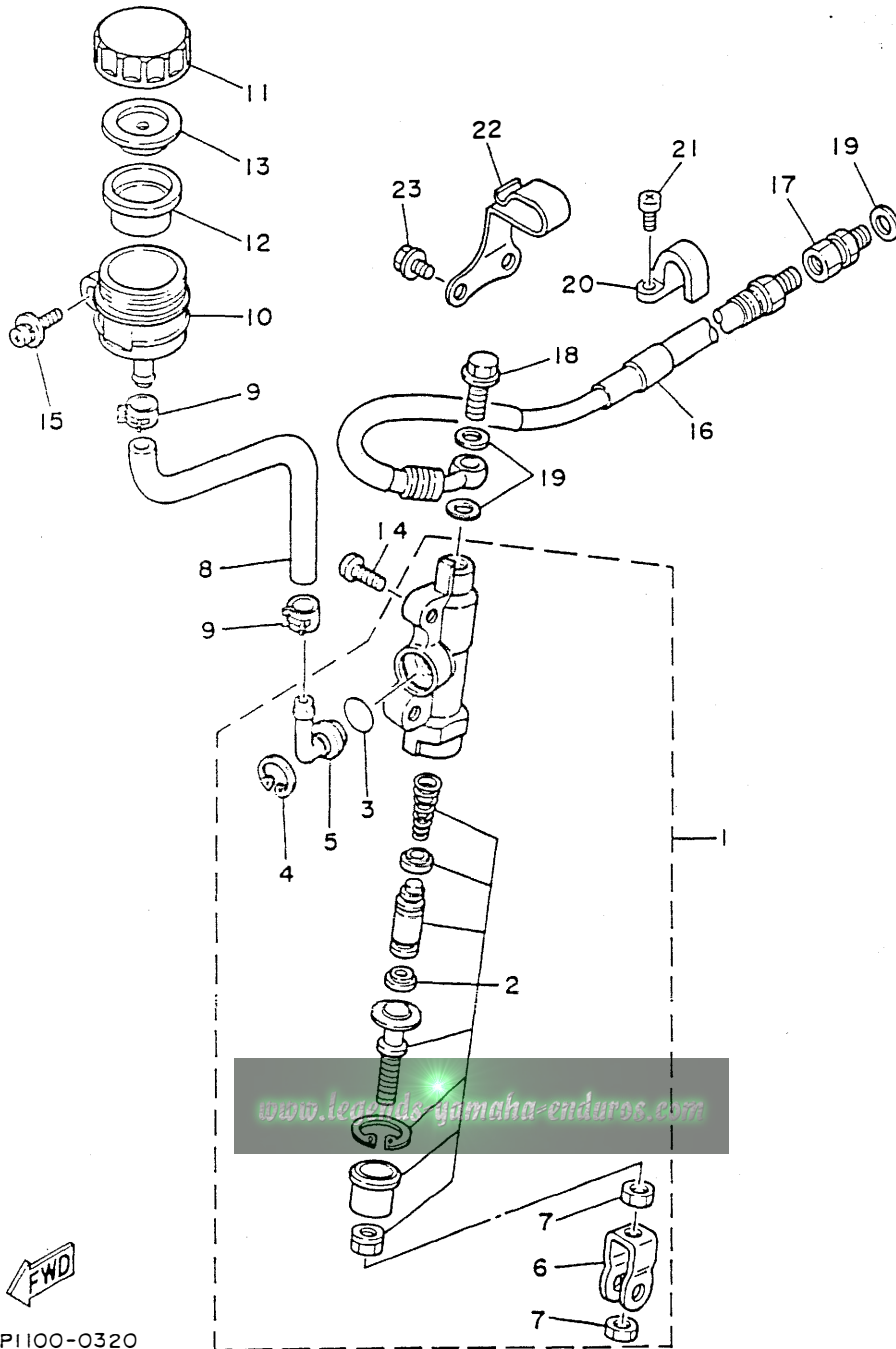

REF. NO.	PART NO.	DESCRIPTION	Q'TY	REMARKS
1	3SP-2583V-00	RR. MASTER CYLINDER ASSY.	1	
2	1FK-W0042-50	.CYLINDER KIT, master	1	
3	93210-15620	.O-RING	1	
4	2VN-25866-00	.CIRCLIP	1	
5	2VN-2582A-50	.JOINT	1	
6	3SP-27222-00	.JOINT	1	
7	95303-08600	.NUT	2	
8	3JD-25895-00	HOSE, reservoir	1	
9	90467-11044	CLIP	2	
10	2VN-25894-00	TANK, reservoir	1	
11	2VN-25852-50	CAP, reservoir	1	
12	2VN-25854-00	DIAPHRAGM, reservoir	1	
13	2VN-25855-00	BUSH, diaphragm	1	
14	92013-06016	BOLT	2	
15	90159-06056	SCREW, with washer	1	
16	3SP-25873-00	HOSE, brake 2	1	
17	3LC-25885-00	JOINT	1	
18	90401-10034	BOLT, union	1	
19	90201-10118	WASHER, plate	3	
20	2VM-25876-00	HOLDER, brake hose 2	1	
21	97780-50510	SCREW, tapping	2	
22	90462-12195	CLAMP	1	
23	95023-06008	BOLT	2	



3SP1100-0320

D14

FIG. 33 GENERATOR

REF. NO.	PART NO.	DESCRIPTION	Q'TY	REMARKS
1	3SP-85550-10	ROTOR ASSY	1	
2	3RB-85560-11	BASE ASSY	1	
3	90149-06011	SCREW	2	
4	90179-10394	NUT	1	
5	90201-10774	WASHER, plate	1	

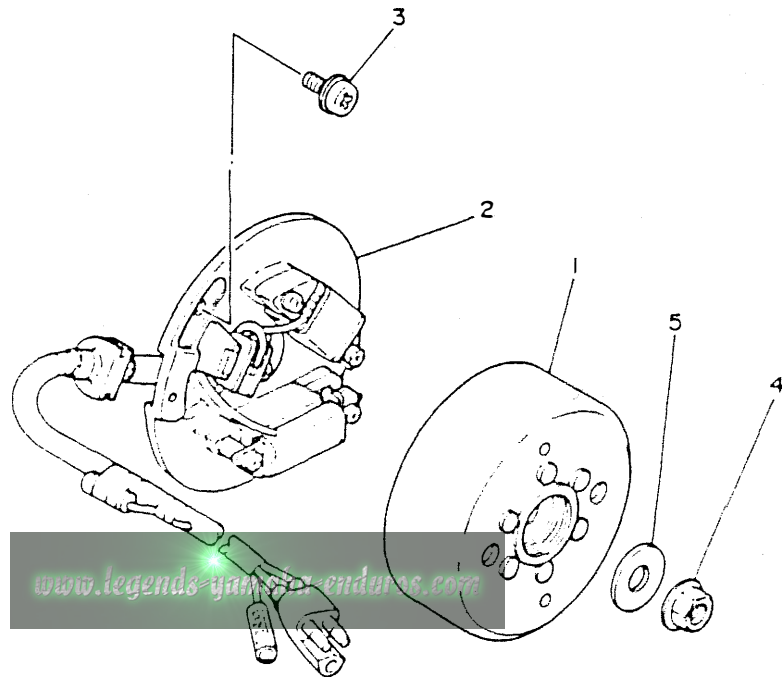

www.legends-yam.com-enduse.com



3RB2100-0330

D15

FIG. 34 HANDLE SWITCH. LEVER

REF. NO.	PART NO.	DESCRIPTION	Q'TY	REMARKS
1	38V-82911-00	HOLDER, lever 1	1	
2	38V-82913-00	HOLDER, lever lower 1	1	
3	23X-83912-00	LEVER 1	1	
4	90109-06799	BOLT	1	
5	95616-06100	NUT, u	1	
6	97006-05016	BOLT	2	
7	3SP-83922-00	LEVER 2	1	
8	90109-06577	BOLT	1	
9	95616-06100	NUT, u	1	
10	90149-06153	SCREW	1	
11	90170-06010	NUT	1	
12	23X-83976-00	SWITCH, handle 1	1	
13	437-83936-01	BAND, switch cord	2	

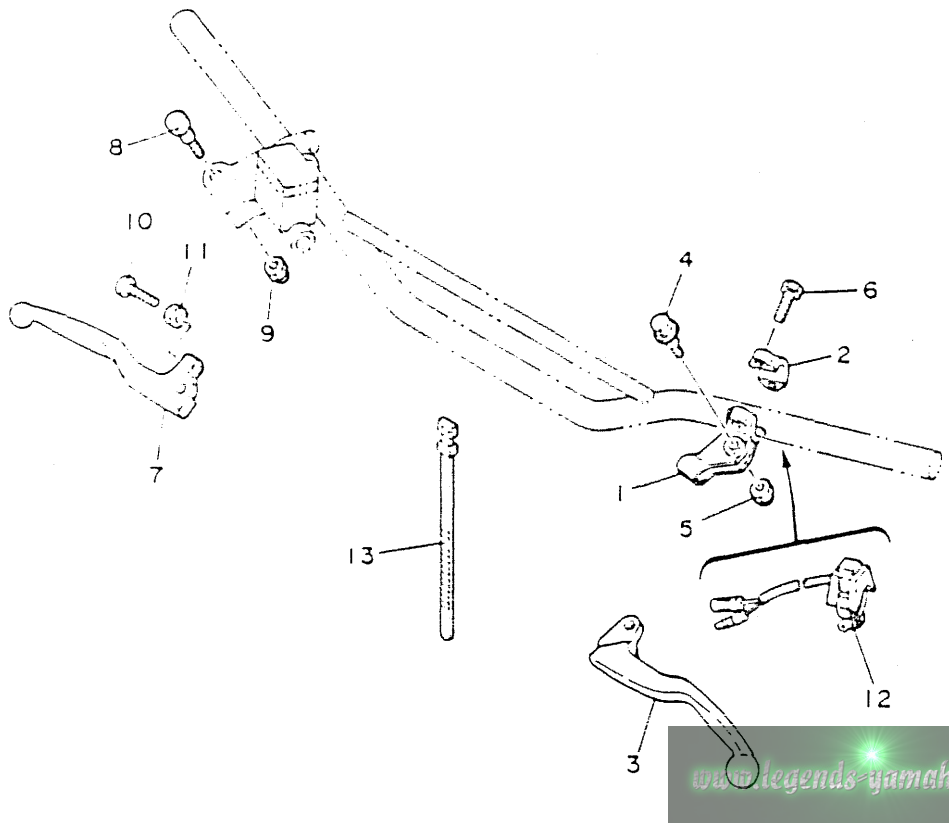

3SP1100-0340

E2

FIG. 35 ELECTRICAL 1

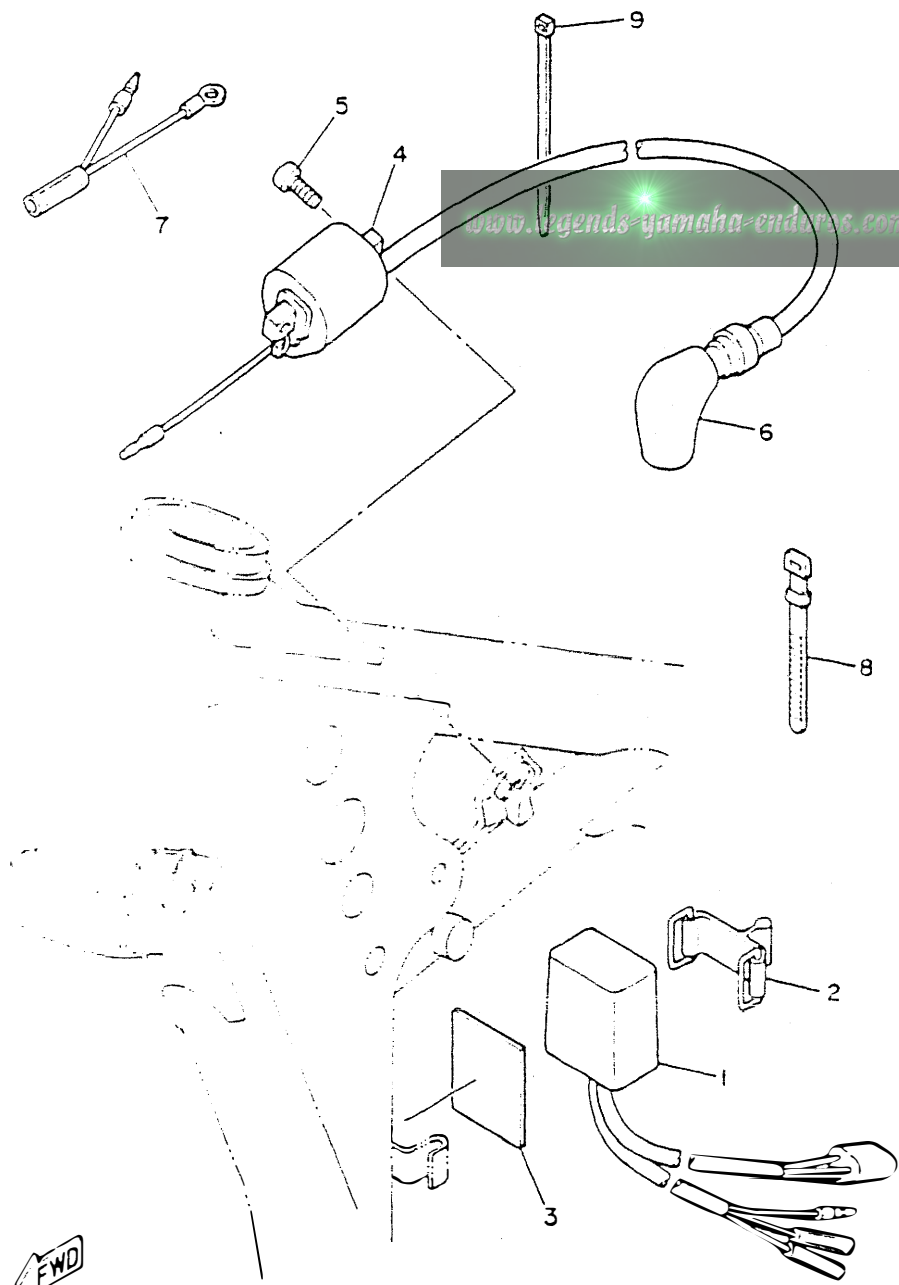

REF. NO.	PART NO.	DESCRIPTION	Q'TY	REMARKS
1	3RB-85540-11	C.O.I. UNIT ASSY	1	
2	5H9-21376-00	BAND, tool	1	
3	3RB-85547-01	DAMPER	1	
4	3SR-82310-10	IGNITION COIL ASSY	1	
5	97021-06016	BOLT	2	
6	3R0-82370-20	PLUG CAP ASSY	1	OR
	2TV-82370-00	PLUG CAP ASSY	1	OR WITH NOISESUPPRESSOR
7	5X1-82519-01	WIRE, earth lead	1	
8	25G-83936-01	BAND, switch cord	1	
9	12R-82591-00	BAND	1	

FWD

3SP1100-0350

E3

FIG. 36 ALTERNATE (CHASSIS)

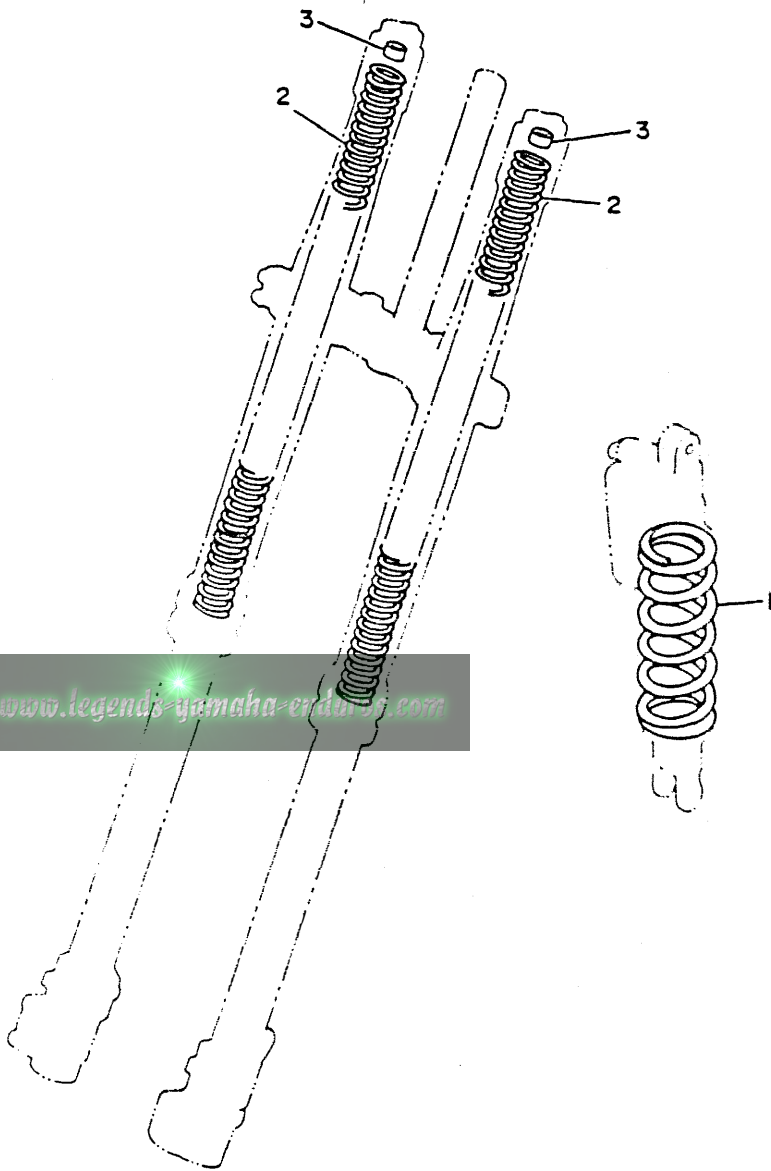

REF. NO.	PART NO.	DESCRIPTION	Q'TY	REMARKS
1	3XJ-22212-10	SPRING (K=4.8)	1	AP (SOFT)
	3XJ-22212-30	SPRING (K=5.2)	1	AP (HARD)
2	3XJ-23141-30	SPRING, front fork (K=0.380)	2	AP (SOFT)
	3XJ-23141-50	SPRING, front fork (K=0.400)	2	AP (HARD)
3	3XJ-23364-L0	COLLAR 2	1	UN

www.legends-yamaha-eridun.com



3XJ1100-1360

E4

FIG. 37 REPAIR KIT

REF. NO.	PART NO.	DESCRIPTION	Q'TY	REMARKS
1	3XK-11630-00	PISTON ASSY (STD)	1	AP
2	3XK-11631-00-80	.PISTON (STD)	1	
3	3XK-11601-00	.PISTON RING SET (STD)	1	
4	2VM-11633-00	.PIN, piston	1	
5	93450-19052	.CIRCLIP	2	
6	3SP-11650-00	CONNECTING ROD ASSY	1	AP
7	5X5-11651-02	.ROD, connecting	1	
8	3JE-11681-00	.PIN, crank 1	1	
9	90209-25085	.WASHER	2	
10	93310-425T1	.BEARING, cylindrical	1	
11	93310-418E9	.BEARING, cylindrical	1	

www.legends-yamaha-enduros.com

E5

NUMERICAL INDEX

PART NO.	GRID NO.	PART NO.	GRID NO.	PART NO.	GRID NO.	PART NO.	GRID NO.	PART NO.	GRID NO.	PART NO.	GRID NO.
3SP-W0041-00	D-12	3SP-11992-10	B- 3	137-14143-74	B-10	2K7-16154-00	B-15	3XJ-21717-00	C- 7	3XJ-23113-L0	C-15
1FK-W0042-50	D-14	3SP-11993-10	B- 3	137-14143-76	B-10	3SP-16154-00	B-15	3XJ-2172A-00	C- 9		D- 2
3SP-W0045-00	D- 7	2VM-11995-00	B- 3	137-14143-78	B-10	2VM-16181-00	B-15		C- 9	3XJ-23120-L0	C-15
2SP-W0046-00	D-10	3SP-1240A-00	B- 7	3JD-14147-00	B- 9	3XK-16321-00	B-15	3XJ-21721-00	C- 9	3XJ-23125-L0	C-15
3JD-W0047-00	D- 7	3SP-12422-00	B- 6	3JE-14147-00	B- 9	3XK-16325-00	B-15	3RB-2173L-20	C- 9		D- 2
3JD-W0047-50	D-10	2VM-12428-10	B- 6	3SP-14149-00	B- 9	2VM-16351-00	B-15	3XK-21731-00	C- 9	3XJ-23136-L0	C-15
1UY-W0048-50	D- 7	2VM-12450-00	B- 6		B-10	2VM-16356-00	B-15	3XJ-2174A-00	C- 9		C-15
	D-10	2VM-12459-00	B- 6	3JD-14185-00	B- 9	3SP-16357-00	B-15	3RB-2174L-20	C- 9	3XJ-2314A-Y0	C-15
3JD-W0057-00	D- 7	3SP-12460-00	B- 7	3JE-14185-00	B- 9	2VM-16371-00	B-15	3XK-21741-00	C- 9		D- 2
3SP-W0057-50	D-10	22W-12462-00	B- 7	353-14186-00	B- 9	2VM-16381-00	B-15	3JD-21748-00	C- 9	3SP-2314E-L0	D- 3
3JE-W1132-00	B- 2	10Y-12469-01	B- 6	363-14187-00	B- 9	2VM-17121-00	C- 2	22W-21791-00	C-10	3SP-2314F-L0	D- 3
3XJ-W1441-00	B- 8	24X-12469-00	B- 7	3JD-14194-00	B- 9	3RB-17131-00	C- 2	3XJ-22110-01	C-11	3SP-2314G-L0	D- 3
5X4-Y113F-00	B- 2	3SP-12476-00	B- 7	3X3-14197-00	B- 9	3RB-17141-10	C- 2	156-22107-00	C-11	3XJ-2314H-L0	D- 3
3SP-Y1543-00	B-13	3SP-1248A-00	B- 7	3JD-14451-00	B- 8	3RB-17151-00	C- 2	3JD-22108-00	C-11	3XJ-2314J-L0	D- 3
3XK-11111-00	B- 2	3SP-12482-00	B- 7	3XK-14453-00	B- 8	3RB-17211-00	C- 2	3R4-22109-00	C-11	3XJ-23141-30	E- 4
3XK-1131A-00	B- 2	3SP-12483-00	B- 7	3JD-14458-00	B- 8	2VM-17221-00	C- 2	1LX-22141-00	C-11	3XJ-23141-60	E- 4
3JE-1131A-10	B- 2	3SP-12485-00	B- 7	3JD-14459-00	B- 8	3RB-17231-00	C- 2	3JD-22147-00	C-11	3XK-23141-L0	C-15
3XK-11311-00	B- 2	353-13115-01	B-12	3JD-14462-00	B- 8	3RB-17241-10	C- 2	3JD-22151-Y0	C-11		D- 2
2VM-11351-10	B- 2	3SP-13565-00	B- 8	3JD-14477-00	B- 8	3RB-17251-00	C- 2	3JD-22156-Y0	C-11	3XJ-23142-L0	C-15
3XK-11400-00	B- 5	3SP-13610-00	B- 8	3JE-14561-00	B- 9	3RB-17411-00	C- 2	3XJ-2215A-00	C-11		D- 2
3XK-11412-00	B- 5	3SP-13613-00	B- 8	3XK-14610-00	B-11	2VM-17421-00	C- 2	3XJ-2215F-00	C-12	3XJ-23143-L0	C-15
3XK-11422-00	B- 5	3SP-13616-00	B- 8	3R4-14613-00	B-11	4L0-17471-00	B-12	3JD-2215G-00	C-12		D- 2
3XK-11601-00	B- 5	2K7-13621-10	B- 8	3JE-14615-00	B-11	3XK-18101-00	C- 5	3JD-2215H-00	C-12	3XJ-23144-L0	C-15
	C- 5	3SP-1410A-00	B-10	3XK-1469A-10	B-11	2VM-18110-00	E- 5	3XJ-2215A-00	C-12		D- 2
3XK-11633-00	E- 5	3RB-14101-00	B- 9	3XK-14747-00	B-11	3XK-18122-00	C- 5	3XJ-2215B-00	C-12	3XJ-23145-L0	C-15
3XK-11631- C-A0	E- 5	3JD-14103-00	B-10	3XK-14753-10	B-11	3XK-18140-00	C- 4	3RB-22201-00	C-13		D- 2
3XK-11631- C-B0	E- 5	3JD-14104-00	B-10	565-14771-00	B-11	3XK-18172-00	C- 5	3RB-22201-10	C-13	4W4-23146-L0	C-15
	E- 5	3JD-14107-35	B-10	483-14781-01	B-11	3XJ-18173-00	C- 5	3RB-22210-00	C-13		D- 2
3XK-11631-00-C0	B- 5	3JD-14112-30	B-10	256-14919-00	B- 9	3XK-18177-00	C- 4	3RB-22210-10	C-13	56Y-23147-10	C-15
3XK-11631-00-D0	B- 5	3JD-14112-35	B-10	2VM-18111-02	B-12	3XJ-18178-00	C- 5	3XJ-22210-10	E- 4		D- 2
2VM-11633-00	B- 5	3JD-14112-40	B-10	4W4-15118-00	B-12	3XJ-18182-00	C- 5	3XJ-22210-20	C- 4	3XJ-23153-L0	C-15
	E- 5	3JD-14112-45	B-10	2VM-18121-01	B-12	3XJ-18184-00	C- 5	3XK-22212-00	C-13		D- 2
3SP-11650-00	E- 5	3JD-14112-50	B-10	103-15362-00	B-13	3XJ-18185-00	C- 5	3SP-22213-00	C-13	4W4-23153-L0	C-15
5X5-11651-02	B- 5	3XK-14115-00	B- 9	3SP-15381-00	B-12	2VM-18511-00	C- 4	3JD-22214-00	C-13		D- 2
	E- 5	275-14116-A6	B- 9	2VM-15411-00	B-13	2VM-18512-00	C- 4	3JD-22216-00	C-13	2VM-23158-L0	C-15
3JE-11681-00	B- 5	275-14116-A7	B- 9	3SP-15415-00	B-13	2VM-18513-00	C- 4	3JD-22224-10	C-13		D- 2
	E- 5	275-14116-A9	B- 9	2VM-15421-00	B-13	1LX-18531-00	C- 4	3SP-22234-00	C-13	3XJ-2316A-L0	C-15
5X5-11911-01	B- 4	275-14116-E0	B- 9	2VM-15451-10	B-13	34K-18535-00	C- 4	3SP-22241-00	C-13		D- 2
5X5-11912-01	B- 4	275-14116-E3	B- 9	2VM-15462-10	B-13	3XK-18540-00	C- 4	3XJ-22253-00	C-13	3XJ-23166-L0	C-15
1LX-11915-00	B- 3	214-14118-00	B- 9	3SP-15463-10	B-13	3XK-21110-00-U0	C- 6	40M-22274-00	C-13		D- 2
5X4-11921-02	B- 4	3JD-14131-00	B- 9	3SP-15620-00	B-14	3XK-21123-00-U0	C- 6	3XJ-22255-00	C-11	3XJ-23167-L0	C-15
3JE-11922-00	B- 4	3H1-14142-35	B- 9	3SP-15621-00	B-14	5H9-21376-00	E- 3	3JD-22475-00	C-13	3XJ-23170-L0	C-15
3JE-11931-00	B- 4	3H1-14142-40	B- 9	3R4-15641-00	B-14	3SP-21425-00	C- 6	3XJ-22475-00	C-12		D- 2
3JE-11937-00	B- 2	3H1-14142-45	B- 9	38Y-15651-00	B-14	3XK-21511-00	C- 8	3RB-23102-10	C-15	3XJ-23171-L0	C-15
5X4-11952-00	B- 4	3H1-14142-50	B- 9	2VM-15661-00	B-14	3XJ-21611-00	C- 8	3RB-23103-10	C-15		D- 2
24X-11953-01	B- 4	3H1-14142-55	B-10	2VM-15664-00	B-14	39X-21642-00	C- 8	3XJ-23110-L0	C-15	24M-23184-00	C-13
3XK-11956-00	B-15	137-14143-70	B-10	2VM-16111-00	B-15	3RB-2165A-01	C- 8	3XJ-23111-L0	C-15	3XJ-23340-L0	D- 2
3SP-11990-00	B- 4	137-14143-72	B-10	3SP-16150-00	B-15	3XJ-21711-00	C- 9		D- 2	3SP-23346-L0	D- 3

NUMERICAL INDEX

PART NO.	GRID NO.	PART NO.	GRID NO.	PART NO.	GRID NO.	PART NO.	GRID NO.	PART NO.	GRID NO.	PART NO.	GRID NO.
3SP-23356-L0	D- 3	2VN-25304-00	D- 8	431-26282-01-98	D-11	90119-05193	C-10	90201-10119	D-13	90387-164N2	C-12
3XJ-23357-L0	C-15	3SP-25311-00	D- 8	3JD-26311-00	D-11	90119-06063	C- 8	90201-106F2	C-12	90387-164N3	C-12
	D- 2	3JD-25317-01	D- 8	3XK-26335-00	D-11	90119-06185	B- 8	90201-10774	D-15	90387-167R5	C-12
3XJ-23363-L0	C-15	4V4-25367-00	D- 9	56A-26372-01	D-12		C- 8	90201-12166	C- 4	90387-200Y5	D- 8
	D- 2	3JD-25381-01	D- 8	3SP-27200-00	D-13		C-14	90201-14740	C-12	90387-203V0	D- 8
3XJ-23364-L0	C-15	3SP-25388-00	D- 8	3XJ-27217-00	D-13	90119-06192	C- 9	90201-154E9	B- 4	90387-252F5	B-15
	D- 2	39X-25394-00	D- 8	3SP-27222-00	D-14		C- 9	90201-164H4	C-11	90387-25563	C- 2
	E- 4	5X2-25394-00	D- 6	3SP-27311-00	D-13	90122-06030	B- 8		C-12	90401-10034	D-12
3JD-23389-01	D- 3	39W-25444-01	D- 8	3SP-27411-00	D-13	90123-08090	D-11	90201-17545	B-14		D-14
5Y3-23393-00	D- 2	39W-25445-01	D- 8	3SP-27421-00	D-13	90149-06011	D- 4	90201-20278	C- 2	90430-06016	B-13
2HG-23416-00	C-14	39W-25446-01	D- 8	3SP-27491-00	D-10		D-15	90201-20358	B-14	90430-06166	B- 6
3SP-23418-00	C-14	39W-25448-00	D- 8	56A-28166-00	C- 7	90149-06153	E- 2	90201-22555	C- 2	90430-10207	B-12
3XJ-23435-00	C-14	39W-25450-00	D- 8	3SR-28230-10	E- 3	90149-06272	D- 7	90201-253K0	C- 2	90445-086A8	B-12
3SP-23441-00	C-14	3JD-25451-01	D- 8	2TV-28230-00	E- 3		D-10	90201-265W5	C-14	90445-09058	D- 4
3SP-23442-00	C-14	26A-25452-50	D- 8	3R0-28230-20	E- 3	90151-04048	C-11	90202-05193	D- 4	90445-09100	D- 4
3XJ-23485-01	C-14	3SP-2580T-00	D- 7	5X1-28259-01	E- 3	90157-06048	B-14	90202-08002	C- 6	90446-09010	B- 7
3XJ-23778-L0	C-15	3SP-2580W-00	D-10	688-282535-00	D-11	90159-06016	B-15	90203-13025	B-15	90450-15041	B- 7
	D- 2	2VN-2582A-50	D-14	12R-282591-00	C- 7	90159-06056	D-14	90209-06096	B- 1	90450-17036	B- 7
3XK-24110-00	D- 4	3SP-2582T-00	D- 7		E- 3	90170-06010	E- 2	90209-10311	C- 2	90450-22017	B- 7
5X6-2412F-00	D- 4	3XJ-2582W-00	D-10	38V-282911-00	E- 2	90170-20255	B-15	90209-10315	C- 2	90450-23014	B- 7
24X-24134-00	D- 4	3GD-25827-00	D-10	38V-282913-00	E- 2	90170-26394	C-14	90209-10322	C- 2	90460-01109	B- 3
3SP-24173-00	D- 4	3SP-2583V-00	D-14	23X-283912-00	E- 2	90176-08026	B- 2	90209-15035	B- 5	90460-02020	B- 3
1LX-24181-00	D- 4	2VN-25852-00	D-12	3SP-28392-00	E- 2	90179-08401	D-11		C- 5	90460-02195	D-14
22W-24181-00	D- 4	2VN-25852-50	D-14	255-283936-01	E- 3	90179-10394	D-15	90215-10231	B-15	90464-04117	D-11
	D- 2	2VN-25854-00	D-14	437-283936-01	E- 2	90179-10544	C-12	90215-10232	D- 3	90464-06009	B- 3
3JD-24181-00	D- 2	56A-25854-00	D-12	23X-283976-10	E- 2	90179-13172	B-15	90240-08120	D-13	90467-09005	B- 7
3JD-24181-00	D- 4	2VN-25855-00	D-14	3RB-285540-11	E- 3	90179-20255	C- 3	90240-10117	D-13	90467-10008	D- 4
3RB-24204-00	D- 9	2VN-25866-00	D-14	3RB-285547-01	E- 3	90179-28602	C-14	90200-10245	B- 5	90467-11044	D-14
3RB-24245-00	C- 9	56A-25867-00	D-12	3SP-285550-10	D-15	90179-28603	C-14	90200-10250	C-11	90468-06046	B-14
3RB-24248-00	C- 9	3SP-25870-00	D-12	3RB-285560-11	D-15	90185-14070	C-12	90240-10297	B-12	90468-06523	B- 7
3RB-24250-00	C- 9	3SP-25872-00	D-12	90101-06664	C- 5	90185-16127	C-11	90200-10314	B- 4	90468-06233	B-11
1RX-24311-00	D- 4	3SP-25873-00	D-14	90101-08461	C- 6	90185-18104	D- 3	90200-10358	C-11	90468-06276	B- 7
3XJ-24380-00	D- 4	2VN-25876-00	D-14	90101-08699	D- 3	90201-05785	B- 4	90207-180A7	B-11	90468-06354	D- 4
2VN-24500-00	D- 4	3LC-25885-00	D-12	90105-06553	C- 8	90201-06407	B-11	90207-18441	B- 7	90501-05035	D- 5
4X8-24512-00	D- 4		D-14	90105-08592	C- 6	90201-06570	B- 7	90207-184X4	C- 2	90501-06132	D-12
4X8-24534-00	D- 4	2VN-25894-00	D-14	90105-10614	C-13	90201-06571	C- 3		D- 2	90501-06720	B-14
5X7-24611-01	D- 4	3JD-25895-00	D-14	90109-064F4	B-11	90201-08002	C- 6	90207-104A0	B- 7	90501-08598	B-15
5X7-24612-00	D- 4	3JD-25919-00	D- 7	90109-06577	E- 2	90201-08087	B- 2	90207-104K5	D- 3	90501-140F4	B- 4
3L7-24724-00	D- 5	3SP-25919-51	D-10	90109-06799	E- 2	90201-081A6	C- 6		D- 9	90506-14410	D-13
5D9-24724-00	D- 5	3XJ-25920-00	D-10	90109-08792	D- 8		C- 5	90207-108N4	D- 6	90507-00020	B-11
3RB-24731-20	D- 5	3SP-25924-51	D-10	90109-142F4	C-12		C- 6	90207-108N5	D- 6	90508-14733	B- 4
1LX-24738-01	D- 5	3GD-25933-00	D- 7	90116-08392	B- 2	90201-08612	B-11	90207-109Y1	B-11	90508-25561	C- 4
5X6-24748-10	D- 5	3XJ-26111-00	D-11	90116-08394	B- 2	90201-087A9	B-14	90207-102W0	B- 2	90508-28777	D-13
3RB-24770-20	D- 5	1LX-26241-01	D-11	90116-10314	B- 2	90201-08759	B- 6	90207-103X9	C-12	90508-29742	C- 5
1LX-25104-00	D- 6	1LX-26242-01	D-11		B- 2	90201-08784	B- 6	90207-151V9	D- 5	90508-30743	B-14
3SP-25111-00	D- 6	23X-26243-00	D-11	90116-10547	B- 2	90201-101J1	C- 6	90207-152F2	B- 4	90560-08213	B- 4
322-25118-00	D- 6	5X2-2628H-01	D-11		B- 2	90201-10118	D-12	90207-152Y1	D- 5	90560-12171	C- 5
55U-25181-01	D- 6	23X-26281-00	D-11	90119-05193	C- 9		D-14	90207-160H4	B-12	90560-15352	D- 6

NUMERICAL INDEX

PART NO.	GRID NO.	PART NO.	GRID NO.	PART NO.	GRID NO.	PART NO.	GRID NO.	PART NO.	GRID NO.	PART NO.	GRID NO.
90560-22281	D-11	93104-08040	B- 4	93501-04011	B-14	95023-08016	C- 9	99510-10114	B- 2		
91001-06020	C-11	93104-16074	B- 2	93511-32027	B-15	95023-08020	B-14	99510-12016	B-12		
91002-06010	B-12	93106-22019	C-11	93521-64032	B- 4	95023-08035	C-14		B-13		
91011-08055	C- 6	93106-28023	D- 8	93603-14179	B- 4	95023-08050	C-14	99530-14016	B- 2		
91011-10016	C-12	93108-35004	C-11	93603-22028	B- 6	95026-06025	D-12				
91011-10055	C- 6	93109-20029	C-11	93604-08071	B- 2	95303-08600	D-14				
91011-10120	C- 6	93210-09192	B- 3	93604-10011	B- 6	95601-05100	B- 8				
91021-06012	C- 9	93210-14104	B-13		B-13	95601-08200	C- 6				
91021-06016	C- 9	93210-15620	D-14	93608-33046	C- 5		C- 6				
91311-08025	D-10	93210-16275	B- 6	93824-13029	C- 2		C- 6				
91316-04006	B- 4	93210-19216	B-14	93834-14049	C- 2	95601-10200	C- 6				
91316-06050	B-12	93210-270A8	B- 2	93834-15075	C- 3	95611-08100	D- 8				
91316-06070	B-12	93210-56743	B-11	94108-217X8	D- 6	95611-08200	C- 6				
91401-20015	D-13	93210-77363	B- 2	94111-187X9	D- 8	95611-10200	C- 6				
91401-25020	C-14	93211-11770	B- 2	94209-21277	D- 6		C-13				
	D-13	93300-60814	B- 4	94213-18232	D- 8	95611-12100	C-14				
	D-13		B- 4	94330-21084	D- 6	95616-06100	E- 2				
92011-06012	D-10	93300-60816	C- 6	94340-18086	D- 8		E- 2				
92011-08070	C- 6		C- 6	94416-21455	D- 6	95701-08500	D- 2				
	C- 6	93306-00413	D- 3	94421-18456	D- 8		D- 3				
92013-06016	D-14	93306-00438	D- 3	94581-44116	D- 9	95701-10500	B- 2				
92901-05600	B- 3	93306-20209	D- 4	94681-44001	D- 9	97001-05016	B- 3				
	B- 3	93306-20540	C- 2	94702-00323	B- 2	97003-06012	D- 4				
	B-13	93306-20574	C- 2	94702-00326	B- 2	97006-05016	E- 2				
	D- 6	93306-37802	B- 6	95021-06070	B-13	97021-05020	B- 3				
	D- 9		B- 6	95021-06080	B- 6	97021-05030	B- 4				
	D- 7	93310-23077	B-15	95021-08030	B-11	97021-06016	E- 3				
	D-10	93310-41859	B- 8	95021-08060	D- 2	97301-08040	D- 7				
92902-04100	B- 9		C- 6	95023-06008	B-11	97780-50510	D-14				
92990-03100	B- 3	93310-42571	B- 6		B-13	98021-06025	C- 5				
	B- 9		C- 6		D-14	98501-04030	D- 3				
92990-05100	B- 4	93311-41734	C- 2	95023-06010	B- 3	98501-05012	B- 2				
92990-06100	B- 8	93311-62035	C- 2		B-11	98501-06012	B-12				
	C-11	93315-11206	B-15	95023-06012	B-11		D- 5				
	D- 2	93315-22046	C-11		B-13	98501-06030	B-13				
	D- 4		C-11		D- 5	98503-03008	D- 4				
92990-08100	D- 7	93317-22262	C-11	95023-06016	C-11	98506-05008	B- 3				
92990-10200	C- 6	93317-22263	C-11	95023-06020	B- 7	98506-05016	D-11				
92990-12200	C-14	93332-00067	C-14		B- 8	98511-04012	B- 9				
92990-13600	D- 9	93332-00068	C-14		C-11	98580-03008	B- 3				
93102-12106	C- 5	93342-22208	C-11	95023-06025	B- 6	98580-03010	B- 9				
93102-12224	B-15	93399-99921	C-12		B- 6	98701-06012	B-12				
93102-20281	D- 6	93410-20038	C- 2		B- 7	98701-06035	C-11				
93102-20309	B-14	93410-22039	C- 2		B-13	98706-04012	D-11				
93102-22363	B- 5	93440-25084	C- 2	95023-06030	C- 2		D-12				
93102-32M07	C- 2	93440-30113	C-12	95023-06035	D- 4	98980-06020	D- 4				
93103-10147	B- 6	93450-19052	B- 5	95023-08012	B-11	99009-06600	B- 6				
93103-40091	B- 5		E- 5	95023-08016	C- 9	99009-17400	B-14				